

MAYTAG

Maytag

**1990 Automatic Washer
Service Manual**

16000131
Issued 1990
Revised 7/97

Contents

| | |
|---|------|
| SECTION 1. ELECTRICAL TEST EQUIPMENT | 1-1 |
| APPLIANCE TEST METER | 1-1 |
| VOLTAGE CHECKS | 1-3 |
| CLAMP-ON AMMETER | 1-4 |
| GROUNDING & POLARITY | 1-5 |
| MOTOR TEST CORD | 1-6 |
| | |
| SECTION 2. ELECTRICAL - MECHANICAL TROUBLESHOOTING | 2-1 |
| WASHER WILL NOT FILL (timer model) | 2-1 |
| WASHER WILL NOT FILL FOR A SPECIFIC WATER TEMPERATURE SELECTION | 2-1 |
| WILL NOT AGITATE, BURNS BELT | 2-1 |
| WILL NOT AGITATE - MOTOR IS RUNNING | 2-2 |
| WILL NOT AGITATE ON DELICATE CYCLE, FABRIC-MATIC MODELS | 2-2 |
| WASHER OVERFLOWS | 2-2 |
| NO COOL - DOWN FILL | 2-3 |
| HOT AND COLD WATER TEMPERATURES REVERSED | 2-3 |
| SLOW FILL | 2-3 |
| WASHER WILL NOT FILL FOR RINSE CYCLE | 2-3 |
| FILLS WITH WATER BUT WILL NOT AGITATE. | 2-3 |
| AGITATES CONTINUOUSLY - TIMER WILL NOT ADVANCE | 2-4 |
| WILL NOT SPIN | 2-4 |
| | |
| SECTION 3. SERVICE PROCEDURES | 3-1 |
| CONTROL PANEL | 3-1 |
| WATER LEVEL CONTROL (timer controlled washer) | 3-1 |
| WATER LEVEL SWITCH | 3-4 |
| AIR TUBE AND DOME | 3-5 |
| TIMER | 3-5 |
| WASHER (microprocessor board controlled) | 3-6 |
| LID SWITCH ASSEMBLY (timer model) | 3-14 |
| LID REPLACEMENT | 3-15 |
| FRONT PANEL | 3-17 |
| MOTOR SHIELD | 3-17 |
| MOTOR CARRIAGE | 3-17 |
| MOTOR GROUND WIRE | 3-19 |
| LOW VOLTAGE | 3-19 |
| CAPACITOR KIT | 3-19 |
| TOP COVER | 3-20 |
| TOP COVER RAISED | 3-20 |
| UNBALANCE MECHANISM | 3-21 |
| BLEACH INJECTOR SYSTEM | 3-22 |
| WATER INJECTOR SYSTEM | 3-23 |
| AGITATOR | 3-24 |

| | |
|---|------------|
| LINT FILTER | 3-25 |
| FABRIC SOFTENER DISPENSER | 3-25 |
| CENTER SHAFT SEAL | 3-26 |
| INNER TUB | 3-27 |
| TUB COVER ADJUSTMENT | 3-28 |
| MOUNTING STEM AND BOOT SEAL | 3-29 |
| OUTER TUB | 3-31 |
| SEAL LEAKS | 3-33 |
| TRANSMISSION | 3-33 |
| AGITATION | 3-34 |
| SPIN | 3-36 |
| SPIN CYCLE COMPLETED | 3-37 |
| TRANSMISSION REPAIR PROCEDURE | 3-37 |
| ASSEMBLY PROCEDURE | 3-40 |
| LIP SEAL | 3-42 |
| DRIVE PULLEY AND ROTOR BEARING | 3-44 |
| DRIVE LUG ADJUSTMENT | 3-45 |
| BELTS | 3-45 |
| BRAKE PACKAGE AND RADIAL BEARING | 3-46 |
| DAMPER AREA SERVICE | 3-49 |
| DAMPER REPLACEMENT | 3-50 |
| POLY PUMP | 3-51 |
| WATER VALVE | 3-52 |
| WATER FLOW | 3-52 |
| INLET HOSE SCREENS | 3-53 |
| WATER PRESSURE GAUGE | 3-55 |
| DIVERTER VALVE - SUDS SAVER MODELS | 3-55 |
| SUDS RETURN | 3-56 |
| | |
| SECTION 4. GENERAL INFORMATION | 4-1 |
| PRE-INSTALLATION CONSIDERATIONS | 4-1 |
| DRAIN FACILITIES | 4-2 |
| TEMPERATURE CONSIDERATIONS | 4-3 |
| ELECTRICAL REQUIREMENTS | 4-4 |
| IMPORTANT SAFETY PRECAUTIONS | 4-5 |
| GENERAL SPECIFICATIONS | 4-6 |
| MODEL CHART | 4-7 |
| SCHEMATICS | 4-8 |

INTRODUCTION

This service manual is intended to assist you in diagnosing conditions that may develop in the MAYTAG automatic washer. The first and most important step of any service call is to determine what the complaint is. This is best accomplished by talking with the customer, finding out what the product is, or is not doing, and why they feel a problem exists.

This manual is designed for the technician who is familiar with the operation and construction of Maytag products. Information contained in this manual is intended for use by a qualified service technician, familiar with proper and safe procedures to be followed when repairing an electrical appliance. All tests and repairs should be performed by a qualified service technician equipped with proper tools and measuring devices. All component replacements should be made by a qualified service technician, using only MAYCOR replacement parts.

Improper assembly or adjustment may occur if service or repair is attempted by persons other than qualified service technicians or if parts other than MAYCOR replacement parts are used. Improper assembly or adjustment can cause hazardous conditions.

There can be risk of injury or electrical shock while performing services or repairs. Injury or electrical shock can be serious or even fatal.

This manual is divided into four sections covering Electrical Test Equipment, Electrical-Mechanical Troubleshooting, Service Procedures and General Information.

Section 1 covers Electrical Test Equipment for use on the automatic washer. This section covers general use of the test equipment, along with providing specific information on amperage, wattage and resistance readings which should be seen.

Section 2 covers Electrical-Mechanical Troubleshooting and provides a list of possible complaints. Find the complaint which you feel best matches that provided by the customer and turn to the appropriate page (s). You will find a list of possible electrical and mechanical problems for the complaint, which have been listed in their order of:

1. Ease of checking.
2. Probability.

Systematically eliminating these possibilities will allow you to find and correct the problem.

Section 3 covers Service Procedures. This section will provide information on location of components, disassembly and/or reassembly procedures, the purpose and/or function of the part and in some instances specific checks to be made.

Section 4 covers General Information such as brief specifications, a model chart and schematics.

SECTION 1. ELECTRICAL TEST EQUIPMENT

The equipment required to service Maytag products depends largely upon the condition encountered. Locating a malfunction will often require the use of electrical testing equipment such as:

Appliance Test Meter
Clamp-on Ammeter
Motor Test Cord

Probably the easiest means of testing electrical components is "continuity testing" with an appliance test meter. Continuity is a complete or continuous path from one point in an electrical circuit to another point.

The obvious advantages of being able to check electrical components and circuits without power applied is one of the features of the ohmmeter. Multiple ranges allow accurate determination of resistances of both single components and entire circuit paths. Resistance is measured in "ohms".

APPLIANCE TEST METER

An Appliance Test Meter is a multipurpose tester combining an AC-DC voltage tester with a multiple range ohmmeter.



APPLIANCE TEST METER

SET METER FOR USE AS FOLLOWS:

1. Calibrate meter by touching test probes together and turning adjusting dial until meter reads "0" on the ohm scale. Recheck calibration whenever adjusting dial for ohms settings is changed (replace battery if adjustment will not bring meter reading to "0").
2. Select the scale most easily read and place test probes on respective terminals. When checking a switch, the reading would normally be either open or closed. A reading of 70 on the R x 10 scale would for example be 700 ohms resistance.

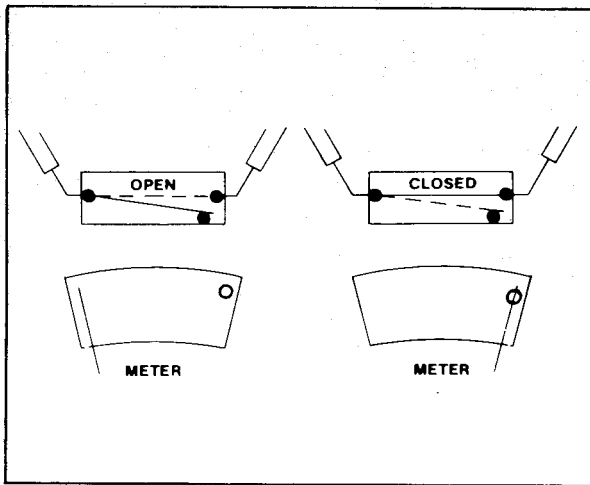

CAUTION

Always be sure the power has been disconnected before making resistance measurements. Failure to do so will result in damage to your meter! Internal batteries provide all the power needed to make resistance checks. They should be checked at least once a year and replaced as needed.

For the most part, we will only be concerned with continuity. Is there a path or not? References are made between a "closed" (continuity) reading and an "open" (no continuity) reading. One note here, when you get an "open" reading, try a higher resistance range (setting). A very high resistance appears as an "open" on the lower ranges. For best accuracy always "re-zero" meter when changing ranges and/or the physical position of the meter.

Continuity testing, as related to an electrical component, is the check of a part for an "open" or "closed" circuit.

Electrical components fall into two general categories.

1. Loads - Devices that use or consume electricity. Examples would include drive motors, heating elements, lamps, timer and solenoid coils.
2. Switches - Devices that control the supply of electricity to the load or loads in a circuit. Examples include door switches, timer contacts, selector switch and relay contacts.

Continuity tests of "load" devices will show varying levels of resistance from very low for some transformer and motor windings to very high for some timer motors and components on electronic control boards. Usually it is more important to know if there is a path for current flow through a device (continuity) than to know the exact resistance (ohms) of the device.

Continuity tests of switches will show virtually no resistance across closed contacts. Resistance, even low values indicates burned or dirty contacts in a switch.

Testing for continuity is a process of eliminating those electrical components involved in a given function of the appliance, until the inoperative part is found. By reviewing the list of possible electrical problems under a given condition, and then performing appropriate

continuity checks on the parts involved, you should be able to locate the electrical component which is inoperative.

When checking components or circuit paths for continuity, external wiring should be disconnected to eliminate false readings through external paths. Isolate what you want to test.

The following chart shows typical resistance values for some of the components found on automatic washers.

| | |
|------------------------------|------------------|
| Water Valve Solenoid Coil | 500 - 900 Ohms |
| Timer Motors | 1100 - 3000 Ohms |
| Diverter Valve Solenoid | 10 Ohms |
| Motor Windings: | |
| Main Winding - Regular Speed | 2 Ohms |
| Main Winding - Slow Speed | 3 Ohms |
| Start Winding | 4 Ohms |

These resistances are not meant to be used as the exact values to determine whether a component is good or bad. They are provided so that you may have an idea of the resistance that you can see in testing components on washers.

VOLTAGE CHECKS

For the most part these checks will consist of taking readings at the wall receptacle in order to determine the availability of voltage to the product. Voltage checks on the individual components of a product are not recommended due to the possibility of electrical shock. If voltage checks are made, use extreme care. Component part testing is best accomplished through continuity checks with an Appliance Test Meter.

Note: Use of the meter on voltage higher than the indicated range may cause permanent damage to the meter. To prevent damage, first select highest range and then lower the range for readings which fall within the lower scale. Also, be sure the meter is set correctly for the type of voltage being checked (AC or DC).

SET UP METER FOR USE AS FOLLOWS:

1. Turn selector knob to desired meter function and appropriate range.
2. Plug black lead into socket marked (-) (black).
3. Plug red lead into socket marked (+) (red).
4. Place test leads into receptacle in order to determine voltage available.

CLAMP-ON AMMETER

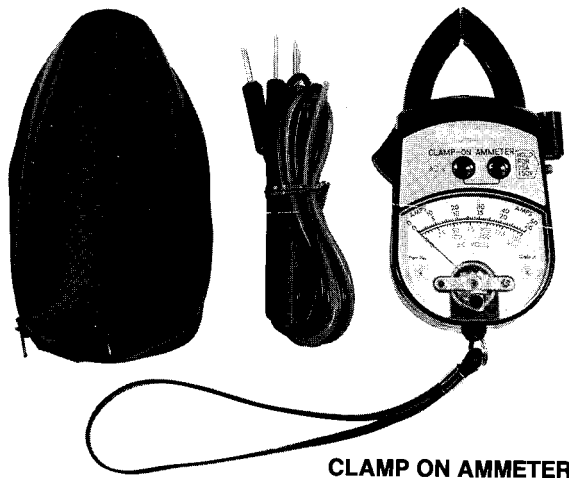

Each circuit in an appliance has a "normal" current draw which is an indication of the performance of that circuit. Current draw levels, less than or more than normal, give clues to malfunctions.

The clamp-on ammeter measures these currents without breaking the circuit by measuring the strength of the magnetic field developed around each conductor. Current is read by separating the conductors and clamping the jaws of the ammeter around each conductor on which current is to be read. Low amperage readings indicate problems such as damaged heating elements, excess belt slippage, etc. High amperage readings indicate the unit being tested is operating under an increased mechanical or electrical load. Worn parts, bearing problems or low voltage will show up as low amperage readings.

Note: Overloads on a circuit breaker or fuse can be traced to the product being tested or the circuit breaker (or fuse) by checking the product's current draw. If the amperage reading is less than the breaker reading, the breaker or fuse box is at fault.

GROUNDING & POLARITY

The receptacle used for all Maytag products operating on 120 volts AC must be properly grounded and polarized.

The power cord used on the appliances is equipped with a three (3) prong polarized grounding plug for protection against shock hazard and should be plugged directly into a properly grounded and polarized receptacle.

Do not cut or remove the grounding prong from this plug.

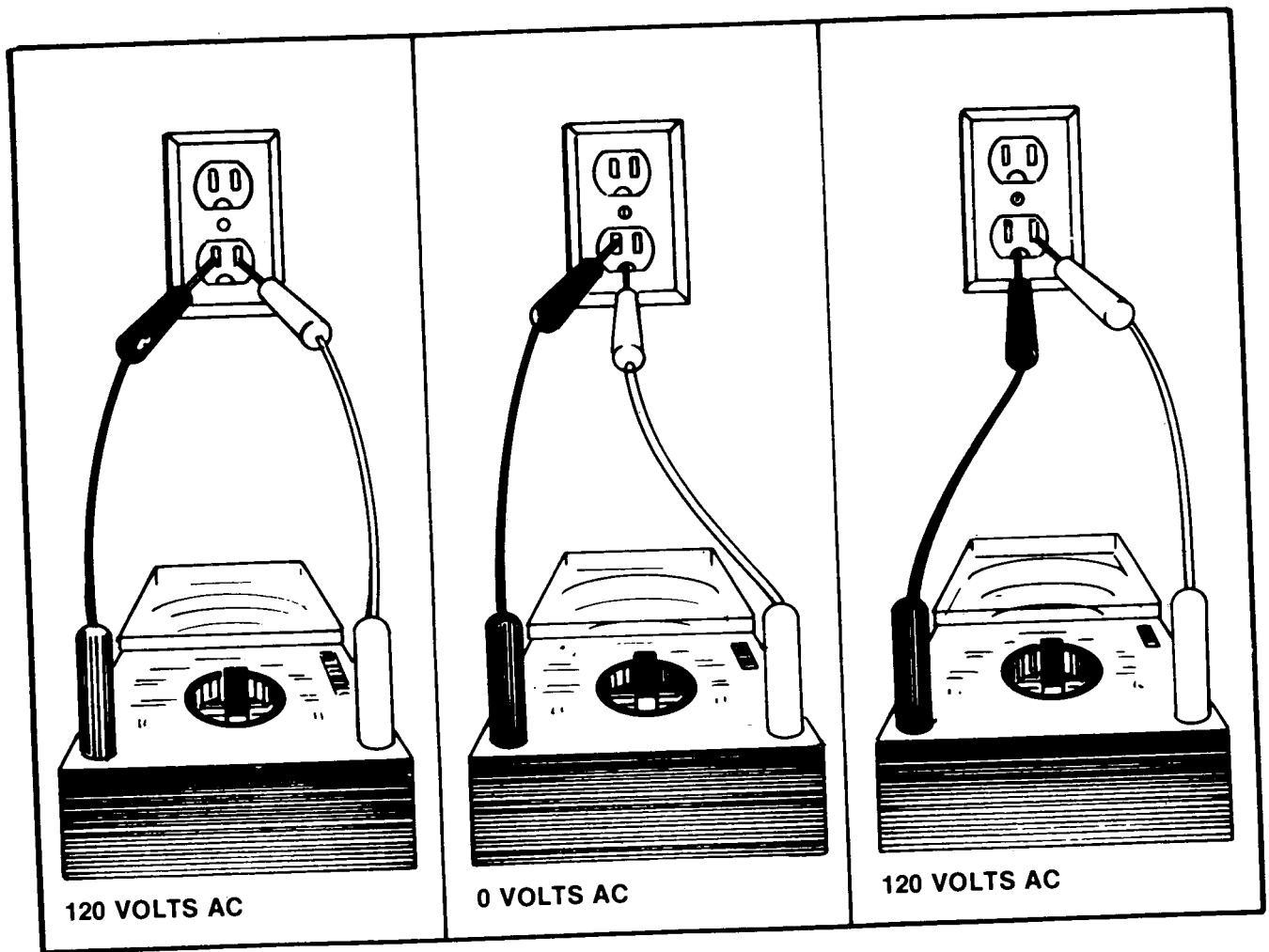

WARNING: For your safety and to protect the test equipment, be sure that the wall outlet is properly polarized and grounded.

MOTOR TEST CORD

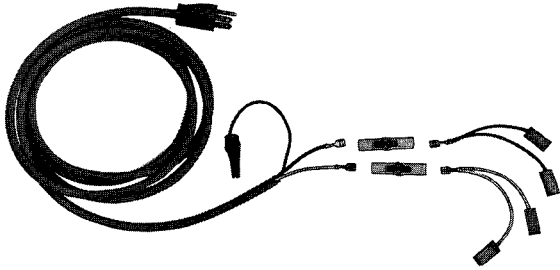

A motor test cord may be used to electrically check operation of the various electrical components without removing them from the unit. Testing in this manner merely determines whether or not the part will function independently of other electrical components. In order to make accurate tests, proper connection of the motor test cord is important. With the aid of the following drawings, installation of the motor test cord may be done quickly and accurately.

NOTE

Always plug test cord into a grounded receptacle.

DRIVE MOTOR TEST - WASHERS

The motor may be checked in the washer or removed and checked on the bench.

2-1805 SINGLE SPEED - REVERSIBLE - DRIVE MOTOR

All four leads of the test cord are required to test the automatic washer drive motor. The following drawing shows installation of the test cord on the 2-1805 drive motor (agitate cycle). Reversing the motor to spin is accomplished by reversing wires B and C.

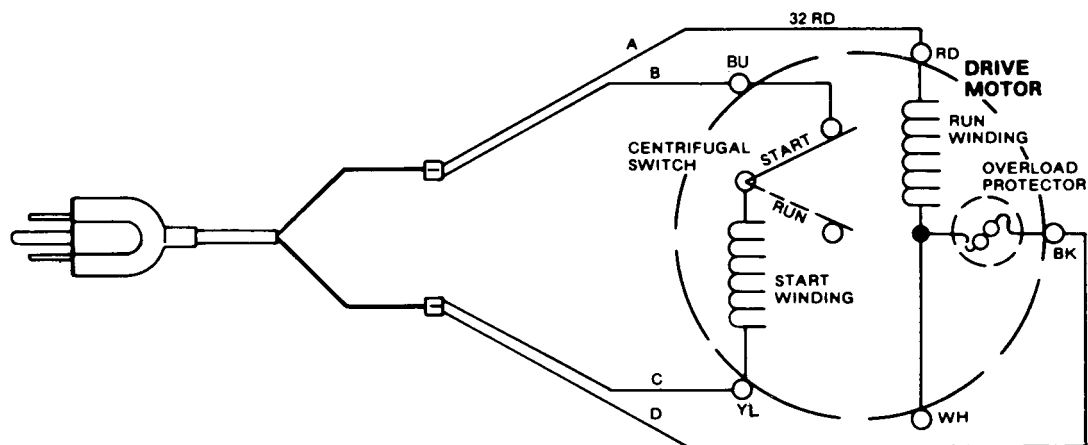

2-1807 TWO-SPEED-REVERSIBLE-DRIVE MOTOR

The following drawings show the connections for the motor test cord on the 2-1807 drive motor (agitator cycle).

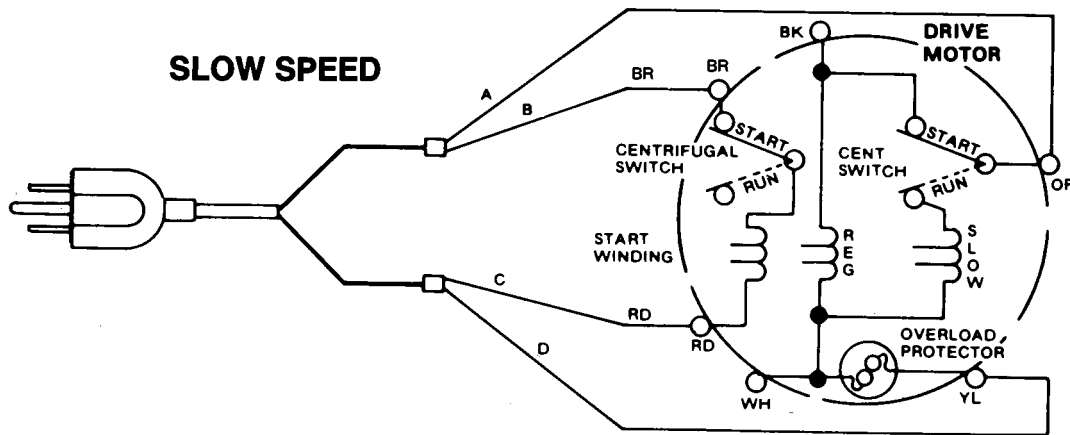
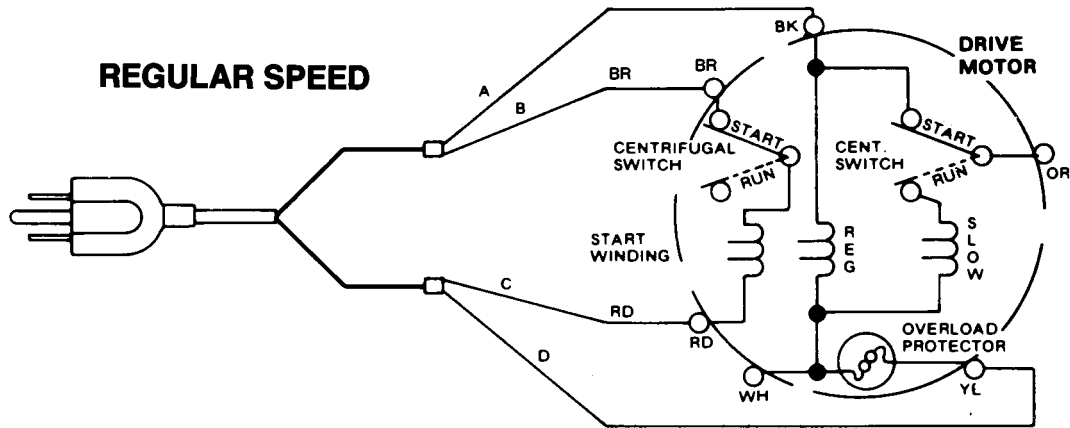

Reversing the motor to spin is accomplished by reversing wires B and C.

SECTION 2. ELECTRICAL - MECHANICAL TROUBLESHOOTING

WASHER WILL NOT FILL (timer model).

Check to make sure water faucets are turned on.

Is washer plugged into power supply?

Pull out timer knob.

Push water temperature selector button.

Check for blown fuse or tripped breaker.

Check fuse on lid switch assembly. If failed, check lid switch for proper operation.

Check timer line switch for continuity.

Check water level switch for continuity between terminals 7 and 15. No continuity, replace switch.

Check timer.

WASHER WILL NOT FILL FOR A SPECIFIC WATER TEMPERATURE SELECTION

Push temperature switch buttons to determine which water temperature is not available (hot or cold).

Check to make sure water faucet is turned on.

Check for continuity on water valve solenoid(s).

WILL NOT AGITATE, BURNS BELT

Burned pump belt. Remove pump belt and turn pump pulley by hand. If pump pulley will not turn, check for an object stuck in pump. If no object is found, pump is seized, replace pump.

CAUTION

Always disconnect power supply before making any continuity checks or resistance readings.

Burned drive belt. Check pump belt adjustment by pulling motor forward so drive belt is tight. Grasp the pump belt in the middle and with the belt tight there should be 1/4" between the inside surfaces of the pump belt. If not, adjust by moving the pump.

Check for binding motor carriage. If binding, clean upper and lower tracks. Replace glides, springs and lubricate.

Remove drive belt and turn large drive pulley by hand counterclockwise (looking at it from the bottom). If pulley will not turn, the transmission is locked and will need to be serviced.

WILL NOT AGITATE - MOTOR IS RUNNING

Check to make sure drive belt is on.

Check to make sure motor pulley turns freely or has not fallen off.

Remove drive belt. Turn drive pulley by hand counterclockwise (looking at it from the bottom). If it rotates freely, but still will not allow agitator to oscillate, the transmission will need to be serviced.

WILL NOT AGITATE ON DELICATE CYCLE, FABRIC-MATIC MODELS

Delicate cycle consists of brief periods of agitation and soaks. Refer to schematic.

WASHER OVERFLOWS

Unplug washer. If washer continues to fill, replace water valve. Should washer stop filling, proceed on.

Blow into the water level switch orifice until a clicking noise is heard. Retain air pressure and check continuity on switch terminals between 7 and 16. No continuity, replace water level switch.

Examine air dome hose for leaks.

Unlikely, but possible, an object is blocking the air dome orifice in the outer tub. Remove object.

CAUTION

Always disconnect power supply before making any continuity checks or resistance readings.

NO COOL - DOWN FILL

Will washer fill with cold water for wash? If washer will not fill with cold water for wash, refer to "Washer Will Not Fill".

Check timer for continuity as shown on schematic.

HOT AND COLD WATER TEMPERATURES REVERSED

Check for reversed water inlet hoses.

Check for incorrect wiring of water temperature switch, timer and water valve.

SLOW FILL

Make sure water faucets are completely turned on.

Check for restricted screen in water valve or inlet hose.

WASHER WILL NOT FILL FOR RINSE CYCLE

Check to see if washer will fill with warm and cold water for wash setting. If washer will not fill for wash refer to "Washer Will Not Fill".

Check timer for continuity as shown on schematic.

Check water temperature switch for continuity between terminals shown on schematic.

FILLS WITH WATER BUT WILL NOT AGITATE.

Check water level switch for continuity between terminals 7 and 16. No continuity, replace switch.

Check timer as shown on schematic.

Attach motor test cord to drive motor (refer to Electrical Test Equipment section). If motor will not operate with test cord, replace motor.

Check speed switch on 2 speed models.

CAUTION

Always disconnect power supply before making any continuity checks or resistance readings.

AGITATES CONTINUOUSLY - TIMER WILL NOT ADVANCE

Check timer motor. If timer motor is not operating, replace.

Timer motor runs but timer will not advance. Replace timer.

WILL NOT SPIN

Will washer fill with water? No. Check to see if washer is plugged into power supply. Check timer line switch.

Will washer agitate after fill? No. Check lid switch. Check water level switch for continuity between 7 and 16. Check timer, refer to schematic. Check speed switch on 2 speed models.

CAUTION

Always disconnect power supply before making any continuity checks or resistance readings.

SECTION 3. SERVICE PROCEDURES

CONTROL PANEL

To Remove Control Panel

Disconnect washer from power supply.

Remove the two inside screws from top of panel and tilt away from console.



With the control panel cover open, you gain access to most of the electrical components.

Depending on the model, you will have access to the following: timer, water temperature switch, water level switch, speed switch, lid switch, micro-

processor board, motor relays and transformer.

WATER LEVEL CONTROL (timer controlled washer)

There are two types of controls used on the water level switch: pushbutton control and infinite level control.

PUSHBUTTON CONTROL

The amount of water in the tub is selected by pressing one of the buttons that corresponds to that level.

The large capacity model has a three-level pressure switch: Small, Medium and Large.

The extra large capacity model has a four-level pressure switch: Small, Medium, Large and Extra Large.

The service procedures are the same for both.

The water level is controlled by varying the pressure exerted on the switch diaphragm when the desired control button is depressed. For example, assume that the Extra-Large control

button is depressed for the "Fill" portion of the cycle. The control arm "A" will lock in position on bar (B), thus depressing the tension bar. As the tension bar is depressed, the spring (C) between the bar and switch is depressed, exerting pressure against the diaphragm in the switch, which will hold the electrical contact in the "Fill" position.

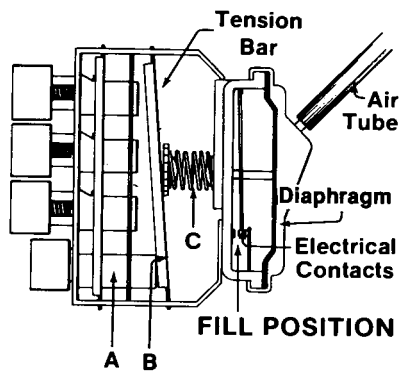

As water enters the washer and the level begins to rise, it flows into the air dome. This creates pressure on the diaphragm through the air tube. When the water reaches a predetermined level, the pressure is sufficient to overcome the pressure exerted on the diaphragm by the pressure switch. As

the diaphragm rises, the electrical contact arm is moved from "Fill" to the "Run" position.

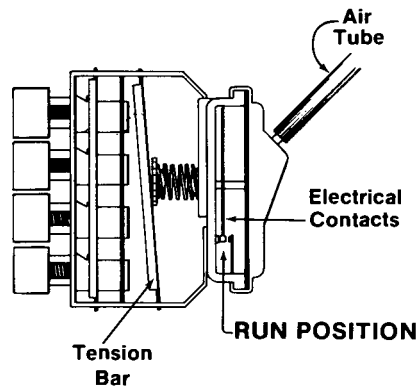

As water is drained from the washer during spin, water is also drained from the air dome, lowering air pressure in the air tube. This allows the switch contact to reset to the "Fill" position.

If the setting of MEDIUM or SMALL is used, there is less pressure applied to the tension bar, resulting in a decreased amount of air pressure required to trip the contact arm to the "Run" position.

INFINITE LEVEL CONTROL

The amount of water in the tub is selected by moving the level indicator to the desired level on the legend. The large capacity model may be set on Small, Medium, Large or any place between. The extra large capacity model may be set on Small, Medium, Large, Extra-Large, or any place between.

When the level indicator is in the down position, there is no pressure on the diaphragm inside the pressure switch.

As the level indicator is raised, a tapered cam on the back side of the indicator comes in contact with an arm which pushes against the diaphragm. When the level indicator is pushed all the way up (to a point where resistance is met) the maximum pressure is applied to the diaphragm and it will take a full tub of water to overcome the pressure applied to the pressure switch, moving it from "Fill" to the "Run" position.

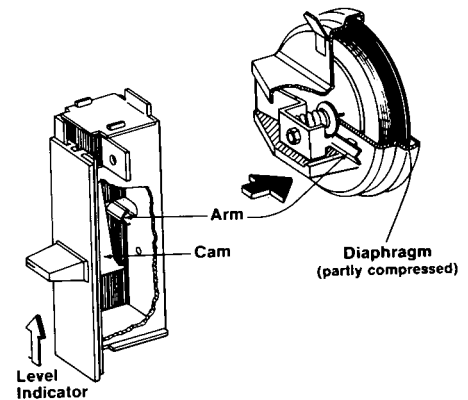
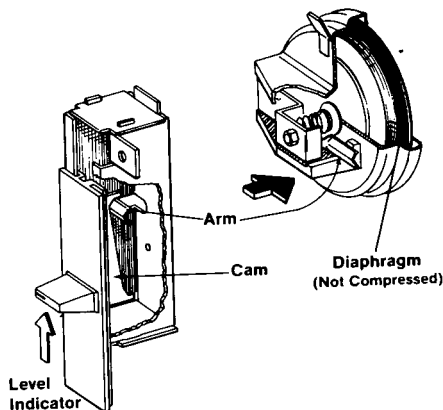

RESET

This allows the user to change to a larger setting once the washer has stopped filling and started to agitate. The user pushes the level indicator all the way up until a resistance is met and then they continue to push the lever until it stops. This moves the contacts in the pressure switch from "Run" to "Fill" and the control can be reset to increase the desired water level.

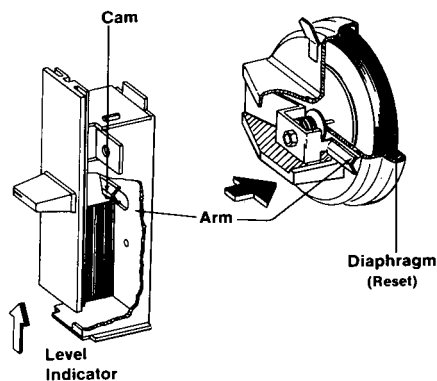

WATER LEVEL SWITCH

If the switch is functioning erratically, remove the air tube from the switch end and blow out the air tube. The washer should be emptied of any water. This will ensure that the air tube is clear for proper switch operation. If this procedure is not followed, any water trapped in either the air dome or upper air tube can cause the switch to falsely actuate and start the washer agitating before

the proper water level is reached. If water is found in either of these areas, check the hose for an air leak.

Water normally in the air dome will be drained when the washer is emptied. However, if any water is drawn into the air tube above the air dome, this water cannot be removed from the air tube by merely siphoning the washer.

Therefore, when a new switch is installed, blow out the air tube from the switch end.

All hose connections should be checked to make sure that they are airtight since air or water leaks will cause improper operation of the switch. No attempt should be made to adjust the water level switch. The switch has been factory calibrated for proper balance of conditions which must be maintained to assure proper operation of the water level control. Field adjustment is not recommended. If there are any questions on proper operation of the switch, the switch should be replaced.

To Remove Water Level Switch:

1. Disconnect washer from power supply.
2. Remove control panel and tilt away from console.
3. Loosen clamp on air tube and remove tube.
4. Remove the two screws securing the switch to the back up plate.
5. Remove the wires from the switch.

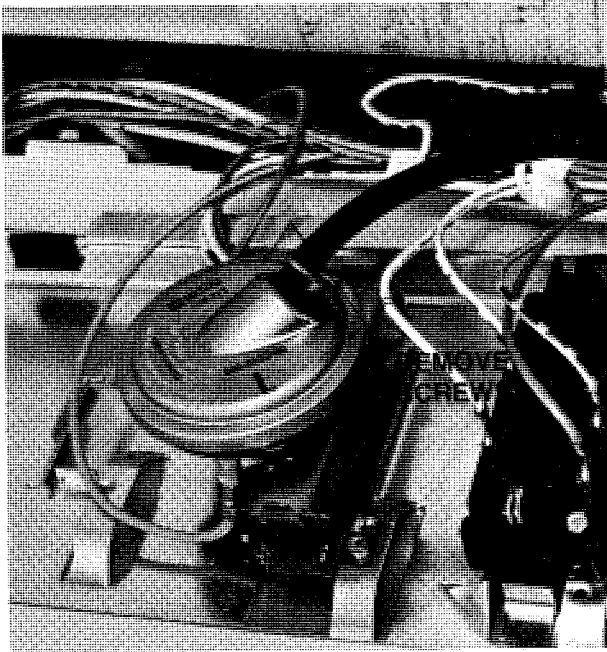

AIR TUBE AND DOME

A single piece air tube and air dome is used on all models. The air tube end is connected to the spout on the water level switch. The air dome end is connected to a spout on the outer tub.

To remove:

1. Disconnect washer from power supply.
2. Remove the two inside screws from the top of the control panel and tilt away from console.
3. Release clamp and remove air tube from water level switch.
4. Remove air dome access plate on back of washer.
5. Release clamp and remove air dome from the tub spout.
6. Pull air tube out of top cover and remove through access. Before

removal, note routing of air tube and position of air dome on tub spout.

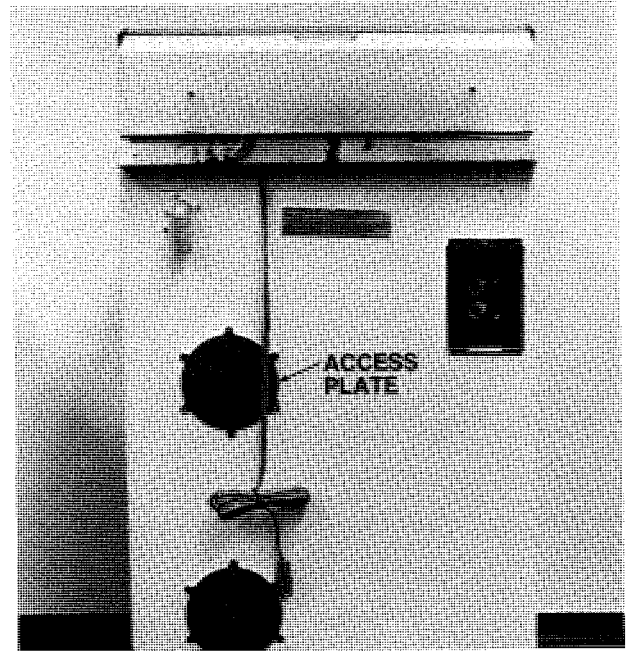

TIMER

A timer is a series of switches driven by an electric motor. These switches control the fill, agitation and spin of a washer. These functions can be done at the same time, such as filling and spinning, as in the spray rinse.

Timer removal:

1. Disconnect washer from power supply.
2. Pry the cap off and pull the retainer clip off the timer shaft. Remove the timer knob, spring and dial.

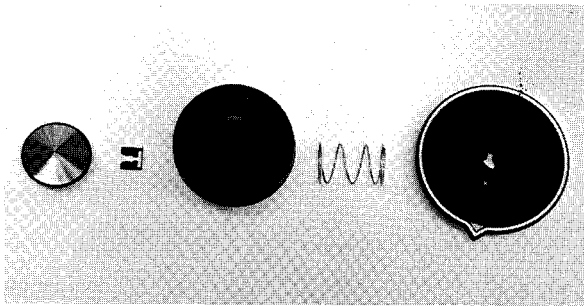

- Remove wires from timer. **NOTE:** Always replace by wire number.

If the timer will not advance, it usually requires replacing the timer motor. Check parts manual for part number.

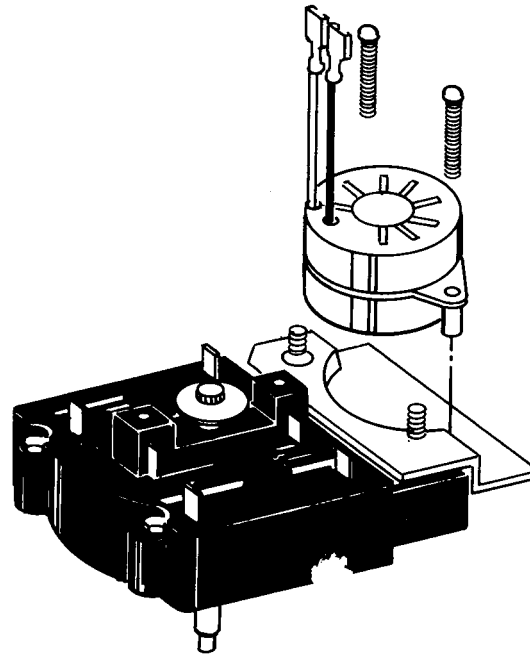

Timer motor removal:

- Follow procedure to remove timer.
- Remove the two screws holding timer motor to timer.
- Remove timer motor wires from timer.

Note: The timer shaft pin is longer on one side. This is to prevent the dial from being installed incorrectly.

- Remove the two screws holding the timer in position. Note which set of holes the mounting screws are located in.
- Remove the two inside screws on the control panel and tilt away from the console.

WASHER (microprocessor board controlled)

This model uses a microprocessor board to control the fill, agitate and spin cycles instead of a mechanical timer. The components involved with these cycles are the microprocessor

board, transformer, water level switch, motor relays and lid switch.

MICROPROCESSOR BOARD

The microprocessor board controls the operation of the washer. It is an electronic circuit board that is located in the console and is attached to the back of the touch pad. It receives the data as the user selects the type of cycle and options by pressing the indicated areas on the touch pad. The touch pad does not function as a switch but as a menu to make selections. Behind the touch pad are switch actuators (push rods) that actuate switches on the microprocessor board when the user makes the selections.



Microprocessor Board Fault Codes

1. F1 in display indicates failure, replace microprocessor board.
2. F4 in display indicates failure, replace microprocessor board.

3. F9 indicates low voltage but will not appear in display unless the following key sequence is performed. Press OFF, and while holding OFF, actuate PAUSE for two seconds. After the entire display turns on, then off, the code will be displayed.

To remove microprocessor board:

1. Disconnect washer from power supply.
2. Remove the two inside screws on the control panel.
3. Tilt control panel out and remove the three edgeboard connectors from the microprocessor board.
4. Remove the eight nuts that secure the microprocessor board to the touch pad.

To remove touch pad:

1. Follow procedure to remove microprocessor board.
2. Remove the four nuts that secure the touch pad to the control panel.

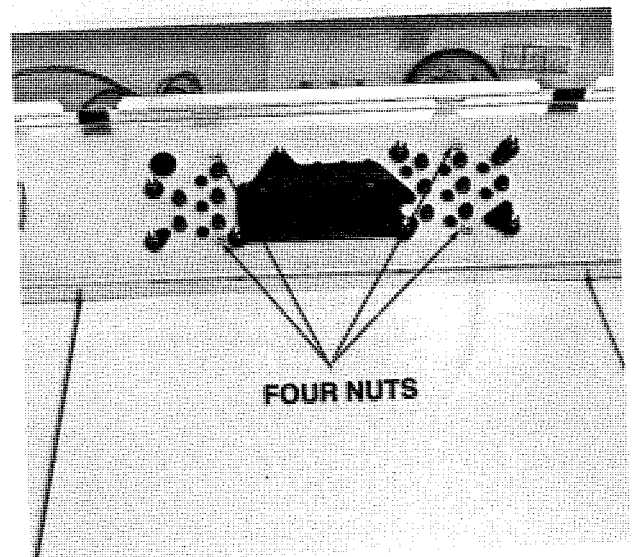

TRANSFORMER

The transformer is a step-down transformer that is used to transform the incoming line voltage to different values for use by the microprocessor board. The secondary side of the transformer has three windings that are connected to the microprocessor board through edgeboard connector CC (see schematic).

CAUTION

Always disconnect power supply before making continuity checks or taking resistance readings.

Checking the transformer:

1. Disconnect washer from power supply.
2. Primary side. Remove the two wires, R-BK and BR, from the transformer and check for continuity. No continuity, replace transformer.
3. Secondary side. Remove the wires from individual winding and make continuity check. Check across Y-BK and Y-BK, no continuity, replace transformer. Check across W-OR and W-OR, no continuity, replace transformer. Check across PK and PK, no continuity, replace transformer.

CAUTION

Use extreme care when checking voltage.

4. Primary side. With volt meter connected across terminals, R-BK and BR, check for line voltage (120 volts AC). No voltage, suspect power supply.
5. Secondary side (3 windings). With volt meter connected across terminals, Y-BK and Y-BK, 20.7 volts AC should be seen. With volt meter connected across terminals, W-OR and W-OR, 3.8 volts AC should be seen. With volt meter connected across terminals, PK and PK, 22.6 volts AC should be seen. If not, suspect transformer or power supply.

Note: These voltages may vary slightly.

To remove transformer:

1. Disconnect washer from power supply.
2. Remove the two inside screws on the control panel and tilt forward. The transformer is located in the right hand corner of the console.
3. Remove wires from transformer or the edgeboard connector from microprocessor board.
4. Remove the two screws securing transformer to top cover.

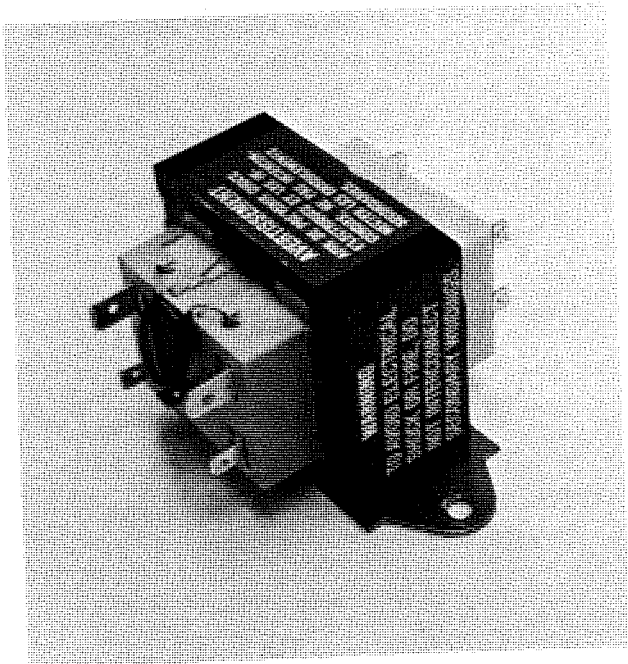

WATER LEVEL SWITCH

The pressure switch on this washer is different from the pressure switch used on the timer controlled washer. There are three switches inside the switch that are actuated by the pressure created in the air dome and tube as the water level in the tub increases. The microprocessor board monitors the electrical circuits created by these switches to control the water level in the tub.

There are five water levels available, low, medium-low, medium, medium-high and high. **NOTE:** For service clarification these levels are taken from the nomenclature on the schematic and will not correspond with the consumer's product information sheet for small, medium, large, normal and extra large settings. The low, medium and high levels are controlled by the switches in the water level switch. The intermediate levels, medium-low and medium-high, are controlled by the microprocessor board. It accomplishes

this by calculating the fill rate. The medium-low level is reached by filling to the low level and then time filling to the intermediate level. The medium-high level is reached by filling to the medium level and then time filling to the intermediate level (see drawing). If something should happen to increase the fill rate, the water level will not exceed the next higher level.

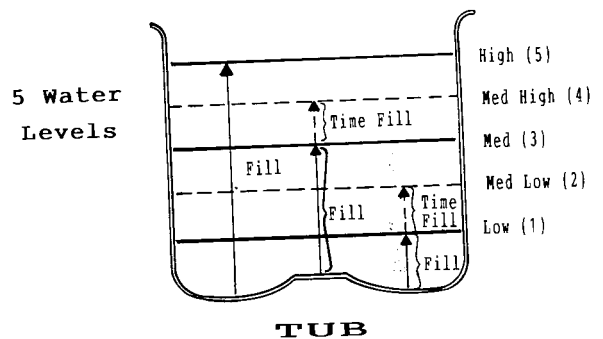

Power from L1 is supplied to the three switches in the water level switch and to the water valve (see schematic). The microprocessor board acts like a switch by controlling the neutral side of the power supply going to the hot and cold solenoids on the water valve (neutral goes to the microprocessor board via pin 3 on edgeboard connector BB and back to the water valve via pin 5 and pin 1). To achieve the proper water level in the tub, the microprocessor board responds to the electrical circuits in the water level switch to determine how long the solenoid(s) should be energized.

There are five available water temperatures, cold, energy saver warm, warm, energy saver hot and hot. Cold is achieved by energizing the cold solenoid on the water valve. Warm is achieved by energizing both the cold and hot solenoids on the water valve. Hot is achieved by energizing the hot solenoid on the water valve. Energy saver warm is achieved by starting with warm, both cold and hot solenoids energized, and the hot solenoid is then cycled on and off every 30 seconds. Energy saver hot is achieved by starting with warm, both cold and hot solenoids energized, and the cold solenoid is then cycled on and off every 30 seconds.

CAUTION

This is a 120 VAC water valve and voltage will be present at water valve whenever the washer is connected to the power supply (except when the contact between 31 and 32 is broken on the water level switch).

Checking the water level switch:

CAUTION

Always disconnect power supply before making continuity checks or taking resistance readings.

1. Disconnect washer from power supply.
2. Continuity checks can be made across the three internal switches. Refer to legend on the schematic to determine condition of the switches (shaded areas indicate continuity across contacts). Example: contacts 31 to 32 will be closed at all

water levels other than High, where the contacts are open.

To remove water level switch:

1. Disconnect washer from power supply.
2. Remove the two inside screws on the control panel and tilt forward.
3. The water level switch is attached to the top cover by a screw and a locating tab. Remove screw.
4. Remove wires from water level switch.
5. Loosen clamp and remove air dome hose.

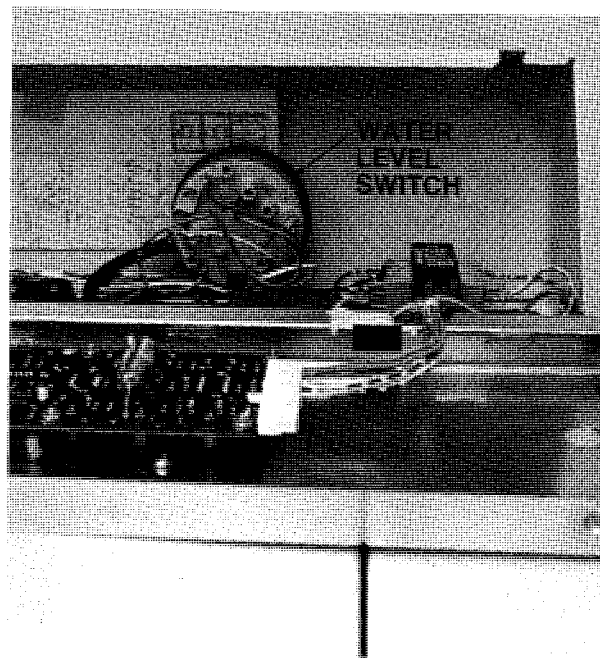

Washer will not fill:

1. Are water faucets turned on?
2. Is washer plugged into power supply.

CAUTION

Always disconnect power supply before making continuity checks or taking resistance readings.

3. Check for continuity across the hot and cold solenoids on the water valve. No continuity, replace valve.
4. Check switches on water level switch for continuity with tub empty. Continuity should be seen across terminals 31 and 32, across terminals 21 and 22 and across terminals 11 and 12. No continuity, replace switch.
5. Transformer. See "Checking The Transformer".

CAUTION.

Use extreme care when checking voltage.

6. Check voltage to water valve solenoids. Place volt meter leads across terminals, O-BK and P-BK, on HOT solenoid and check for line voltage (120 volts AC). Place volt meter leads across terminals, BU-BK and P-BK, on COLD solenoid and check for line voltage (120 volts AC). No voltage, suspect water level switch, microprocessor board or power supply.

Washer overflows:

1. Disconnect washer from power supply.
 - A. If water does not stop, replace water valve.
 - B. If water stops, check for continuity across terminals 31 and 32 on the water level switch (with full tub of water). If you have continuity, replace water level switch.
2. Check for leak in air dome hose.

Not getting selected water temperature:

1. Are fill hoses reversed?
2. Select hot or cold to determine what temperature you are not getting.
3. Disconnect washer from power supply.
4. Make continuity check across the water valve solenoid that will not provide water (hot or cold). No continuity, replace water valve.

MOTOR CONTROL

The speed and direction of the motor are controlled by the microprocessor board through three 24 VDC relays: Fast, Slow and Reversing. The 24 VDC control voltage comes from the microprocessor through edgeboard connector AA (see schematic). There are two different size terminals used on the relays. The smaller terminals are used for the 24 VDC wires and the larger terminals are used for the 120 VAC wires.

The Fast and Slow relays (single-pole, single-throw) are used to control the speed of the motor. These relays carry the same part number and are interchangeable. The Fast relay is energized to provide regular speed and Slow relay is energized to provide slow speed. NOTE: The speed of the motor is determined by the cycle selected.

The Reversing relay (double-pole, double-throw) is used to change the direction of the motor for spin. The relay is de-energized during the agitation cycle and is energized during the spin cycle.

CAUTION

Always disconnect power supply before making continuity checks or taking resistance readings.

Will not agitate:

Agitation Diagnostic: The washer should agitate dry, regular speed only, by pressing the "OFF" and while holding "OFF", press "PRESOAK". Using the results of this test, determine what needs to be checked from following list.

1. Is washer plugged into power supply?
2. Will washer fill with water? If not, refer to "washer will not fill".
3. Disconnect washer from power supply.
4. Check lid switch for continuity. No continuity between terminals L1 and YL with lid closed, adjust or replace switch.
5. Check Fast and Slow relays (depending on speed of agitation).
 - A. Remove W-BK and GY wires on Fast relay and check for continuity. No continuity, replace relay.
 - B. Remove W-OR and GY wires on Slow relay and check for continuity. No continuity, replace relay.
6. Refer to Electrical Test Equipment section for drive motor test.

CAUTION

Use extreme care when checking voltage.

7. Check for voltage at relay (Fast or Slow). With volt meter leads con-

nected across terminals, GY and W-BK on Fast relay, 24 volts DC should be seen for regular agitation. With volt meter leads connected across terminals, GY and W-OR on Slow relay, 24 volts DC should be seen for slow agitation. No voltage, suspect wiring or microprocessor board.

Note: You are measuring DC voltage, set and use meter accordingly.

CAUTION

Always disconnect power supply before making continuity checks or taking resistance readings.

Will not spin:

1. Disconnect washer from power supply.
2. Check continuity across terminals PU and GY on the Reversing relay. No continuity, replace relay.
3. Check Fast and Slow relays (depending on speed of spin) for continuity (refer to "Will Not Agitate"). No continuity, replace.
4. Refer to Electrical Test Equipment section for drive motor test.

CAUTION

Use extreme care when checking voltage.

5. Check for voltage at reversing relay. With volt meter leads connected across terminals, PU and GY on Reversing relay, 24 volts DC should be seen for spin. No voltage, suspect wiring or microprocessor board.

Note: You are measuring DC voltage, set and use meter accordingly.

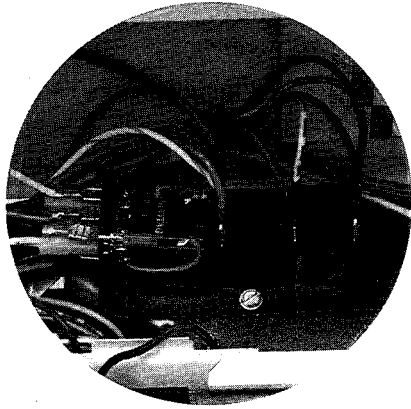

MOUNTING PLATE AND RELAYS

To remove relays:

The relays are located in the left hand corner of the washer behind the control panel. The three relays are mounted on a plate that is attached to the washer top.

1. Disconnect washer from power supply.
2. Remove two inside screws on control panel and tilt forward.
3. Remove the two screws securing the mounting plate to washer top.
4. Reversing relay is secured to mounting plate with a screw and locating tab. Remove screw and remove reversing relay.
5. Fast and Slow relays can now be removed by sliding tabs out of slots.
6. Remove wires from relays

LID SWITCH

The microprocessor board monitors the lid switch to make sure the switch contacts open when the lid is raised (the check switch and fuse are not used on this model). The lid must be opened between programs to implement this test. If this does not occur a "lid" will appear in the display when the next program is selected. This must be cleared by lifting the lid before a program is selected. If opening the lid does not clear the "lid" from the display, assume the lid switch has failed and replace.

Note: The test does not occur if the cycle is ended by the pressing of the "off" key, only if the cycle ends naturally.

Remove lid switch:

1. Disconnect washer from power supply.
2. Remove the two inside screws on control panel and tilt forward.
3. Remove wires on lid switch.
4. Remove the two screws securing the lid switch to mounting bracket.
5. After replacing lid switch, adjust mounting bracket so lid switch will open when lid is raised not more than 1 3/4".
6. Place a 1 inch block between the lid and the washer top. This needs to be located at the front of the lid.
7. Slide the lid switch assembly ahead until a clicking noise is heard from the lid switch.
8. At this point, slide the mechanism slowly back until a clicking noise is again heard from the lid switch (hold in that location).

9. Lock the mechanism in place with the mounting screw and the lid switch assembly is properly adjusted.

Note: It is important to be aware that it is the reset operation of the lid switch that is being set by the above technique. Always check this adjustment by turning washer timer to the spin cycle. Washer should shut off when the lid is raised not more than 1 3/4".

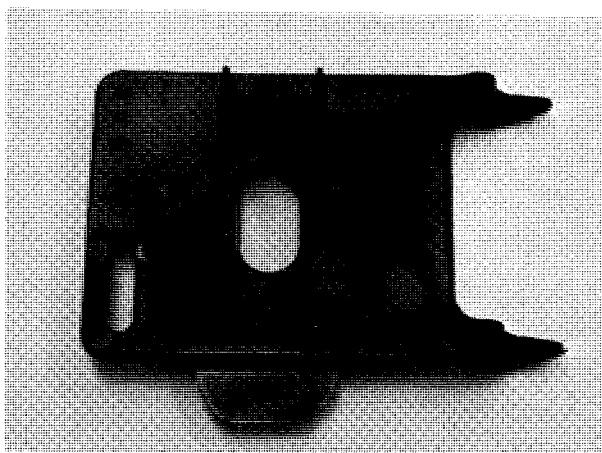

Unbalance Condition:

When a load of clothes becomes unbalanced, the unbalance mechanism will disengage from the lid switch and stop the washer. When this happens the word "UNBALANCED" will appear in the display and an audible signal will sound after a period of 60 seconds. The signal will then sound every 60 seconds until the user lifts the lid, redistributes the clothes in the tub and closes the lid, at which point the cycle resumes.

LID SWITCH ASSEMBLY (timer model)

In order for the washer to agitate, spin or fill the lid switch assembly must be operating properly. The assembly consists of a lid switch, check switch and fuse holder mounted on a bracket. The switches are actuated through the plunger mechanism and unbalance lever when the lid is opened and closed.

The purpose of the circuitry is to open the fuse in the event the lid switch fails. The fuse is in series with the water valve and will prevent the washer from filling with water if it is open. Normal washer operation is resumed only by servicing the lid switch and fuse assembly.

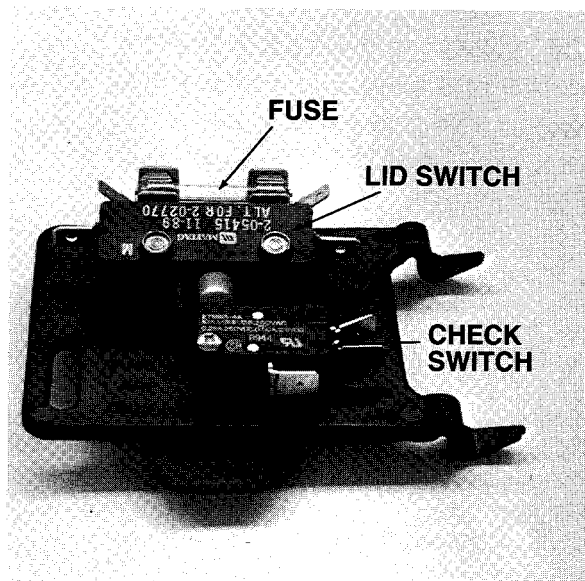

The bracket is secured to the top cover with a screw and locating tabs. The hole for the screw is slotted for adjustment.

To remove bracket:

1. Disconnect washer from power supply.
2. Remove control panel.
3. Remove wires from switch assembly.
4. Remove mounting screw.
5. Lift bracket to release tabs from top cover.

To check lid switch and check switch:

CAUTION

Always disconnect power supply before making continuity checks or taking resistance readings.

1. Remove wires from the switch assembly.
2. Check across terminals of each switch for continuity with switch in open and closed position (see schematic).
3. Replace if necessary.

To check fuse:

1. Disconnect washer from power supply.
2. Remove wires from fuse holder.
3. Check across terminals for continuity.
4. No continuity, replace fuse. **NOTE:** Use a 1 Amp fuse only.

Switch assembly adjustment:

1. Place a 1 inch block between the lid and the washer top. This needs to be located at the front of the lid.
2. Slide the lid switch assembly ahead until a clicking noise is heard from the lid switch.
3. At this point, slide the mechanism slowly back until a clicking noise is again heard from the lid switch (hold in that location).
4. Lock the mechanism in place with the mounting screw and the lid switch assembly is properly adjusted. **NOTE:** It is important to be aware that it is the reset operation of the lid switch that is being set by the above technique. Always check this adjustment by turning washer timer to the spin cycle. Washer should shut off when the lid is raised not more than 1 3/4".

LID REPLACEMENT

To remove lid:

Raise the lid so it is at a 45 degree angle with the top cover.

With the left hand, grasp the left side of the lid toward the back. With the right hand, grasp the right side of the lid at the right front corner.



Hold the lid with the left hand keeping sufficient pressure against the left side to ensure the hinge ball will remain wedged between the lid and the top cover. With the right hand, place a hinge ball in the right side of the top cover recess.

Taking care to watch where the hinge balls go, pull toward you with the right hand.

To replace lid:

Place a hinge ball in the recess of the left side of the top cover. Holding it in position, place the lid over the ball so the ball is in the recess on the left side of the lid.

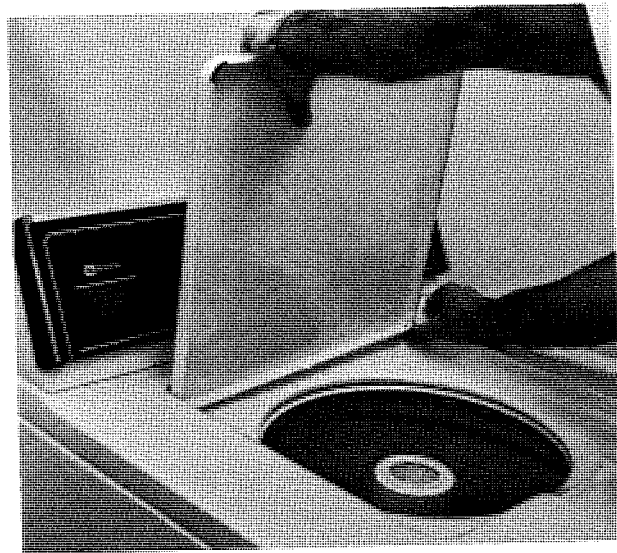

Push the lid down against the hinge ball on the right side and with the right thumb, press down sharply to engage the lid with the hinge ball on the right side.

Note: If the fit between the right hinge ball and the lid is so tight you cannot press it into position with the right thumb, carefully strike the right corner of the lid with the palm of the hand to snap it into position.

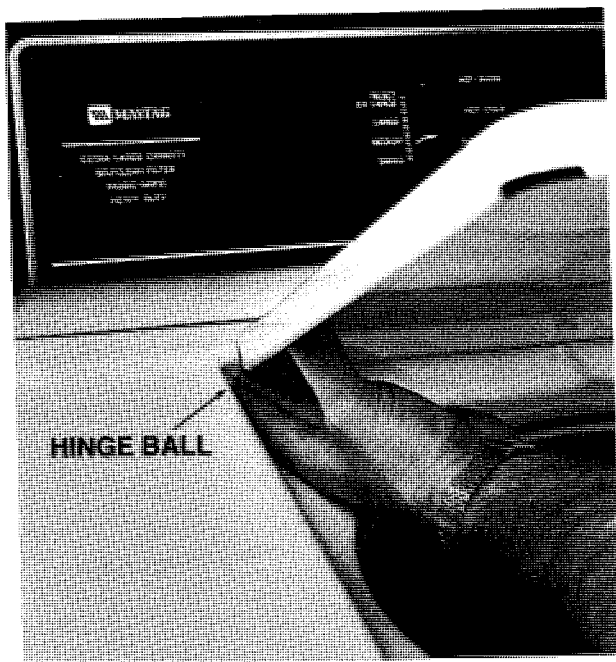

FRONT PANEL

To remove front panel:

1. Remove the two screws under the edge at bottom of front panel.
2. Swing front panel out from bottom to disengage spring fasteners from top cover.

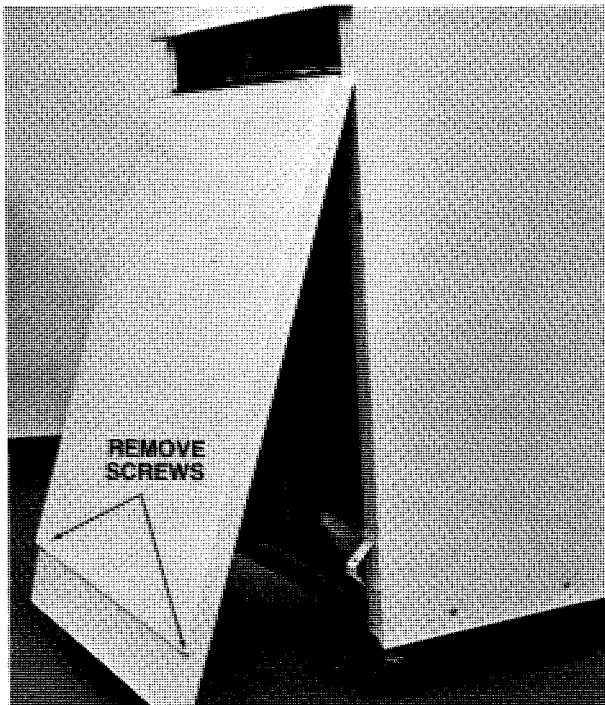

With the front panel off, you have access to the motor, pump, top cover, hoses and transmission. On Suds Saver models the diverter valve is also accessible.

To replace front panel:

1. Engage spring fasteners under the flange on top cover.
2. Swing panel down into position and replace screws.

MOTOR SHIELD

Three holes in the cabinet flange allow positioning of the shield to ensure that it will not interfere with the motor sliding in the carriage. Once installed, move the motor in the carriage to ensure that the end bell does not hit the cover. When installing a new motor, the shield may need to be moved from the original mounting position.

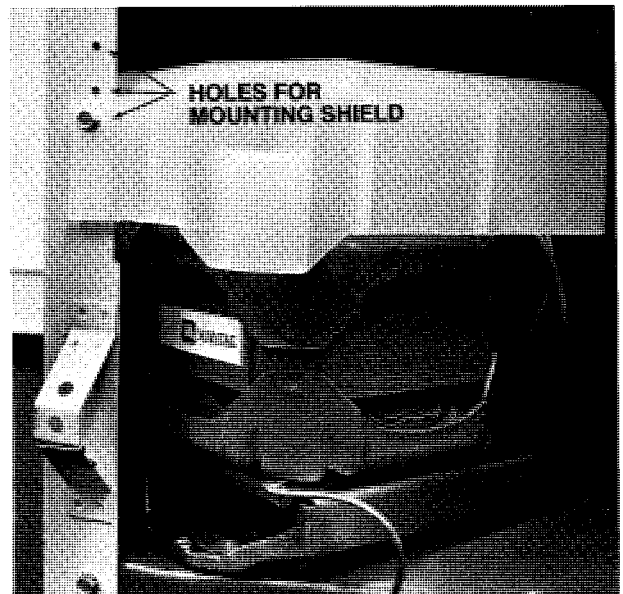

MOTOR CARRIAGE

The motor carriage consists of an upper and lower section. The lower section is mounted to the base frame. The upper section is used to mount the motor. The lower section has two square glides on each side which engage in a track on each side of the upper section. Two tension springs are attached between the two sections. When

removing springs note location of the holes.

During agitation the motor pulley rotates in a clockwise direction as viewed from the top of the motor. The tension of the two springs keeps the motor pulled toward the front of the washer causing the motor pulley to tighten against the drive belt.

During spin the motor pulley rotates in a counterclockwise direction as viewed from the top of the washer. The initial surge caused by the reverse torque of the motor pulls the motor along the track to the rear. The drive belt slips in the drive pulleys so the motor does not absorb the full starting impact and weight of the full tub.

As the inertia of the tub is overcome, the motor is pulled ahead by the tension springs allowing the drive belt to settle into the motor pulley and gradually build up spin speed. The drive belt tension during spin is automatically provided by the two motor tension springs.

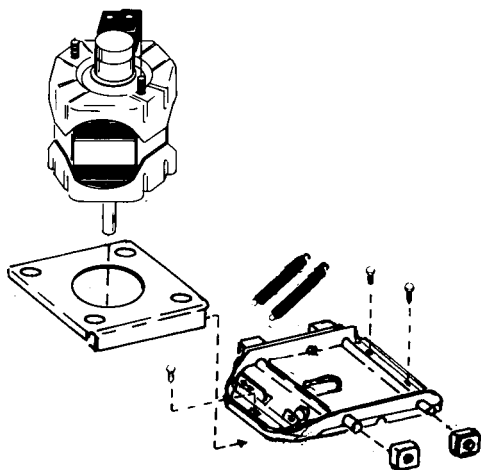

To remove the motor:

The removal of the motor from the washer can be completed with the motor carriage and pulley attached to the motor. A hole in the base allows the pulley to pass through.

1. Disconnect the washer from the power supply.
2. Remove the front panel.
3. Remove the motor shield.
4. Remove the wire harness and ground wire.
5. Remove the front screw that holds the lower section to the base. Remove both belts and pull motor towards the front of the washer. You now have access to the two rear screws that hold the lower section to the base. Remove screws.
6. Lift the motor through the base frame.

To remove motor from motor carriage:

1. Remove pulley.
2. Disengage and remove the tension springs.
3. Remove carriage mounting nuts (to remove two of the nuts, align upper and lower sections and insert wrench through the slots in the lower section).
4. Remove upper section from motor.

With motor removed, carriage and glides are accessible for service. Clean the motor base of any dirt or lint. Lubricate the track and glides with poly lube grease, 2-03959.

To replace motor:

1. Assemble carriage sections.

2. Mount motor to carriage.
3. Install pulley on motor shaft (position so the end of motor shaft is about 1/32" less than flush with bottom of pulley).
4. Insert assembly through base, insert tabs in slots.
5. Replace the two rear screws that secure lower section to base.
6. Replace both belts.
7. Replace the front screw that secures lower section to base.
8. Attach wire harness and ground wire.
9. Replace motor shield.

After the motor has been replaced, it will not be necessary to check or make a drive belt adjustment as the correct tension is automatically applied by the two motor tension springs. However, it will be necessary to check the pump belt for proper adjustment.

MOTOR GROUND WIRE

A 7" green ground wire is attached to the right-hand front of the motor carriage to the washer base. This ground wire provides additional protection to the service technician. To maintain all grounding provisions provided with the appliance, the ground wire must be reinstalled any time removal of the wire is required.

LOW VOLTAGE

In some installations with low voltage, the washer motor will hum and fail to start spinning. If a motor remains too long in the start winding, it will overheat and trip on the overload protector. With a start capacitor added in series with the start winding, the motor will develop additional starting torque helping it out of the start winding faster.

Remember that the main problem is low voltage which should be corrected. A start capacitor is helpful for voltage ranges below 110 volts. Below 105 volts, installing a start capacitor may or may not help.

A start capacitor adds extra starting torque helping the motor get out of the start winding faster. By giving the motor this additional torque, it will not overheat and open the motor overload protector.

CAPACITOR KIT

To make installation of a capacitor easier, there is available a capacitor kit (2-06103). This kit consists of the following items and instructions.

Clip for capacitor (2-11149).

Capacitor (2-00832).

Green No. 17 wire (2-03237).

Pop rivets (2-10720).

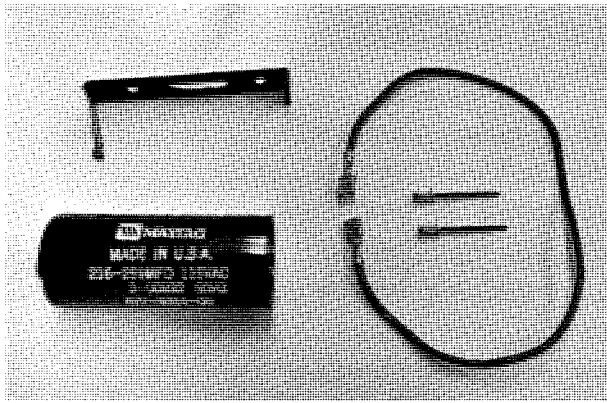

TOP COVER

Remove front panel.

Remove two top cover bolts and tilt the top cover back. Hold the lid while moving the top cover to prevent it from striking the control panel.

On models with a bleach hose, remove hose from the inlet on the top cover.

TOP COVER RAISED

Lid switch and out-of-balance mechanism.

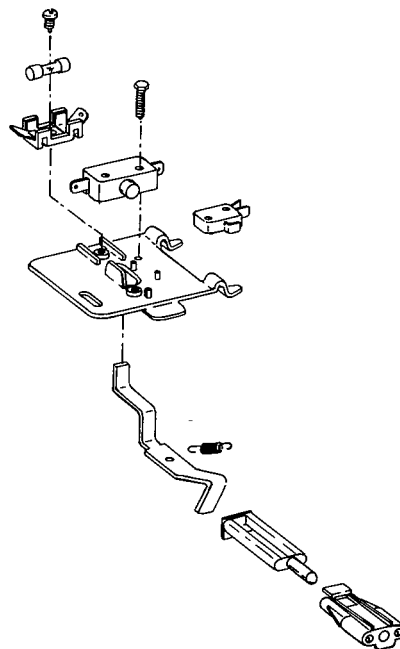

UNBALANCE MECHANISM

The unbalance mechanism is designed to stop the washer if an unbalance condition should occur.

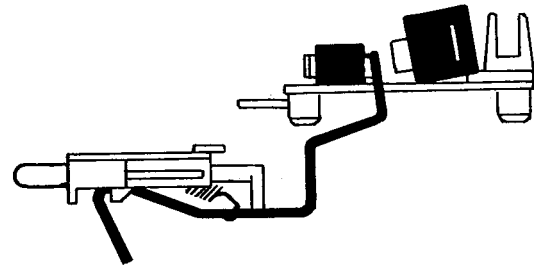
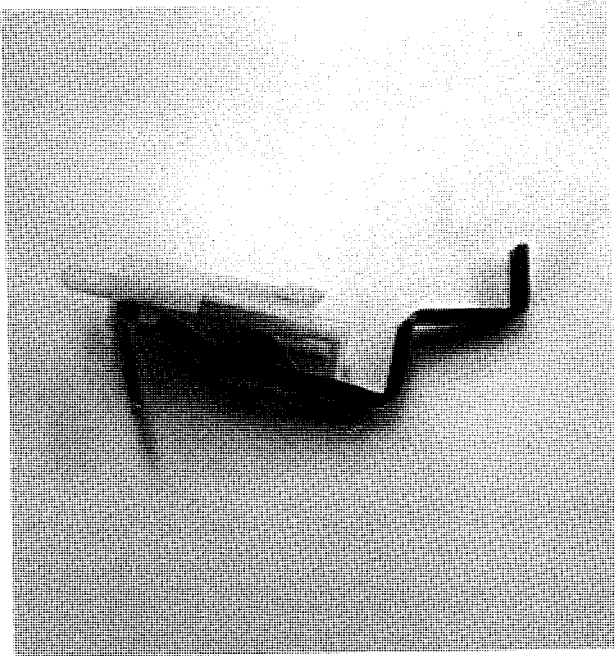

LID OPEN

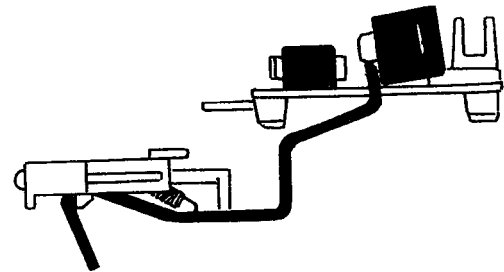

UNBALANCED

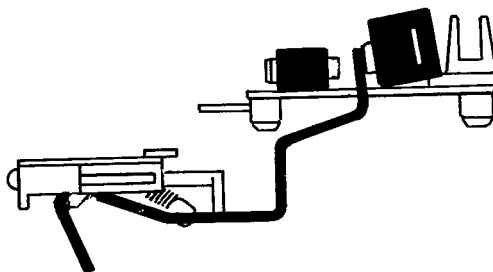

LID CLOSED

When the lid is closed, the lip on the back of the lid pushes the plunger and unbalance lever back, closing the lid switch. A spring is attached between the bracket and the unbalance lever. The spring tension holds the unbalance lever in line with the plunger. When the load becomes unbalanced, the bracket on the tub cover pulls against the unbalance lever, disengaging the lid switch and stopping the washer. The cycle will continue by opening the

lid, rearranging the clothes and closing the lid.

To remove the lid switch and unbalance mechanism:

1. Remove lid.
2. Remove the two screws holding front panel and remove.
3. Remove the two top cover bolts and raise top cover.
4. Remove the screws on each side of plunger to remove assembly. If unbalance mechanism is serviced, check tub centering. Replace washer in original location. Important: Washer must be leveled.

BLEACH INJECTOR SYSTEM

A bleach injector system is used on some models. Bleach is poured directly into the funnel type inlet on the left side of the top cover.

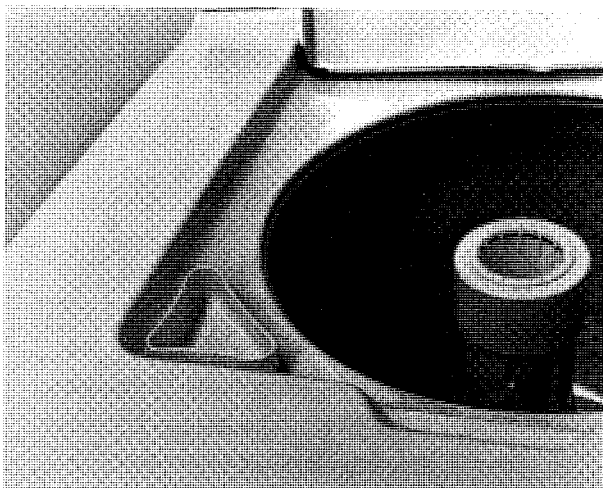

It flows through a hose and directly into the bottom of the outer tub.



Diluting of the bleach occurs during the fill portion of the cycle. During the spin a deflector inside the outer tub prevents the water from being pumped up the bleach tube.

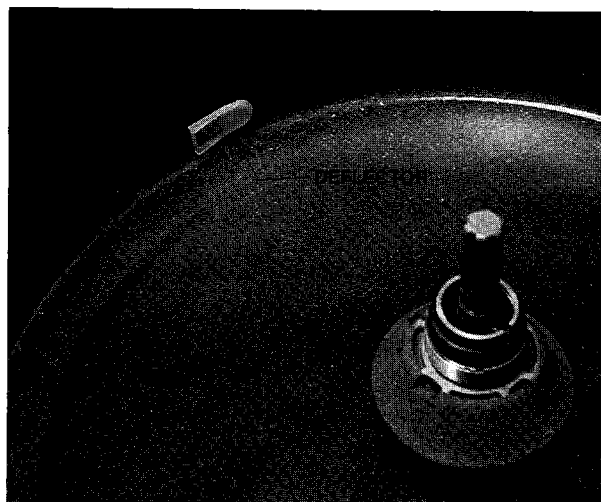

Note: With the inner tub removed the bleach deflector spout can be removed. Pull the tab off from the outside and snap deflector out. It must be replaced as shown to prevent water from being forced out during spin.

To remove bleach inlet:

1. Remove front panel and pull bleach hose off inlet spout.
2. Remove the screws holding the top cover and raise it slightly.
3. Use a block to hold top cover 3" to 4" above the tub cover. Use a material that will not damage the tub cover.

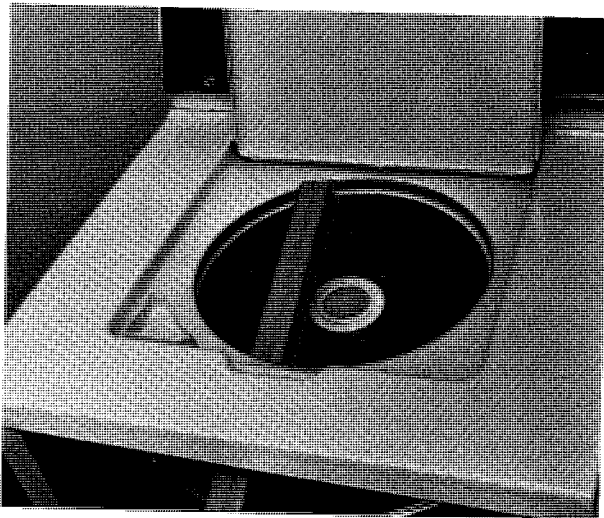

To replace bleach inlet:

1. Apply warm water to the bleach inlet and gasket.
2. Place gasket into opening in top cover.
3. Push the inlet up and into position from the bottom of the top cover.
4. Lower the top cover and replace the screws in each corner.
5. Replace the hose on bleach inlet spout and replace front panel.

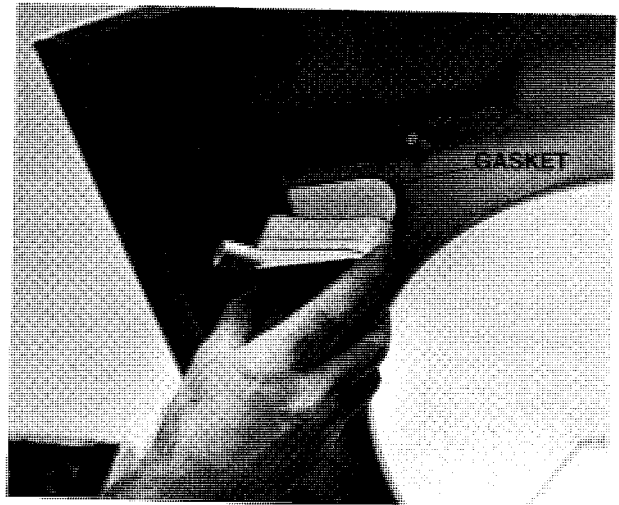

4. With the top cover in this position press down strongly on bleach inlet until it is removed through the bottom of the top cover. Examine the gasket before replacing new inlet. Replace if necessary.

WATER INJECTOR SYSTEM

Water from the water valve enters the tub through an anti-siphon injector valve system.

The parts involved are the injector hose (from the water valve to the injector housing), the injector nozzle (a closed-end nozzle with slots in the sides), the injector valve (a rubber sleeve which fits tightly over the

injector nozzle), the injector housing (the nozzle and valve go inside the housing) and the injector tube (the hose between the injector valve housing and tub cover).

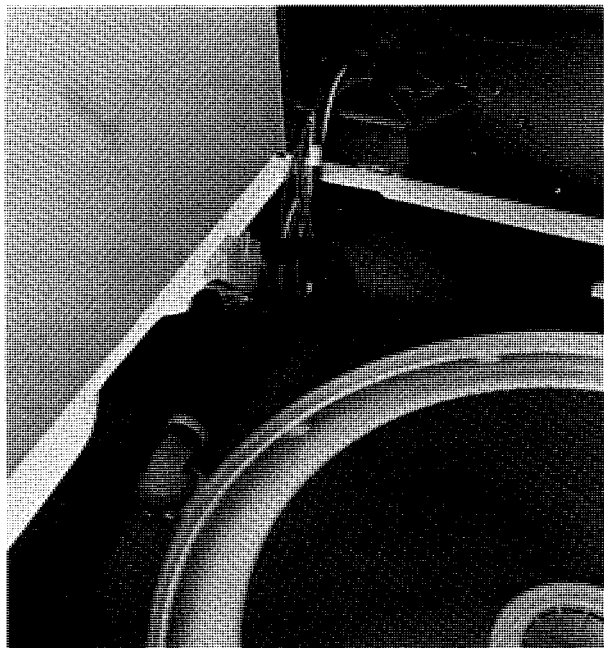

The tabs on the injector tube fit into an opening on the tub cover. After inserting tabs, twist the injector tube to secure it to the tub cover.

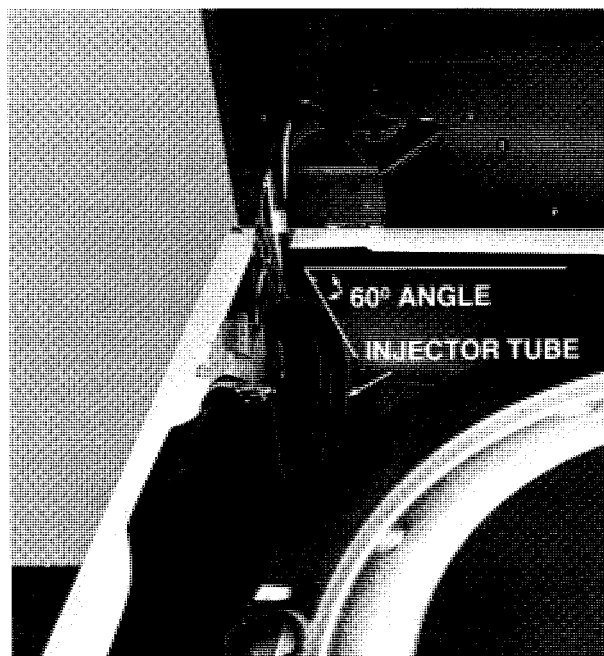

Note: The mounting angle of the injector tube is 60 degrees below a horizontal plane (see photo).

To replace injector valve and nozzle:

1. Remove front panel and raise top cover.
2. Loosen hose clamp and separate injector hose from injector housing.
3. Replace valve and nozzle.
4. If replacing the injector tube, the solid ring clamps will have to be cut off and replaced with hose clamps (2-02515).

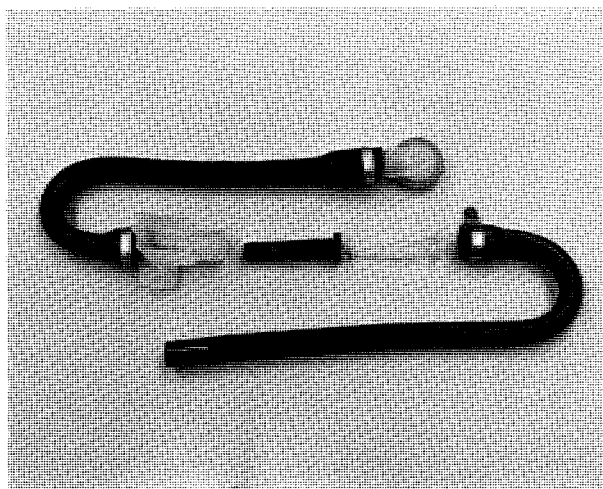

AGITATOR

The "power fin" agitator used on the automatic washer creates a unique water action. This action pushes water through the clothes and at the same time, moves them from the top of the water, to the bottom and back up again.

The water action tends to keep the clothes away from the agitator and out toward the tub.

LINT FILTER

There are two different filtering systems used on the washers. One system uses a filter in the barrel of the agitator while the other system uses two self-cleaning filters located in the bottom of the inner tub.

The filter in the agitator can be cleaned by taking it out of the agitator and removing the lint. The two filters in the bottom of the inner tub are cleaned when the washer goes into spin. The lint is held on the bottom side of the filters and is flushed down the drain with the water.

To remove the self-cleaning filters:

1. Loosen screw located on the side of the agitator.
2. Remove agitator.
3. Pry out filter. It is held in place with several tabs. Grasp filter in the center on the long side. Lift up and push in at the same time to remove filter.
4. Replace filter by pressing into place.

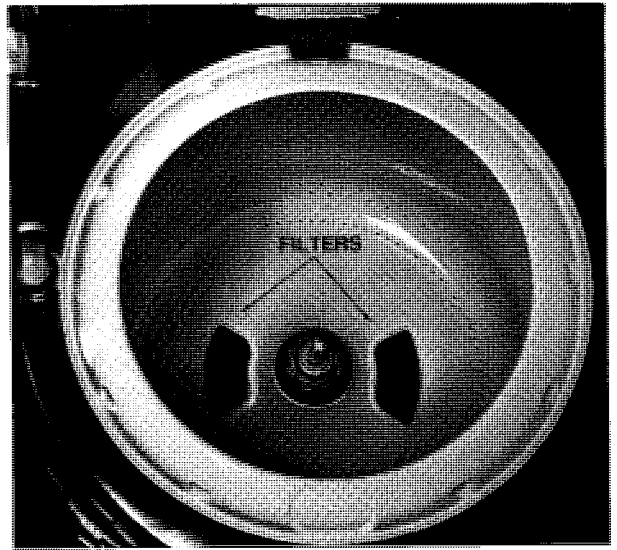

FABRIC SOFTENER DISPENSER

The built-in fabric softener dispenser, located in the top of the agitator, is designed to dispense fabric softener into the final rinse portion of the cycle automatically. Since bleach and granular detergents should not be used in the rinse, they should not be placed in the dispenser cup. Always follow the manufacturer's directions for usage of the fabric softener.

Place diluted softener in dispenser cup before starting washer. During agitation, it remains in the cup.

At the start of the spin for the final rinse, the softener is spun up to the top of the cup and leaves the cup through the slots around the top circumference of cup.

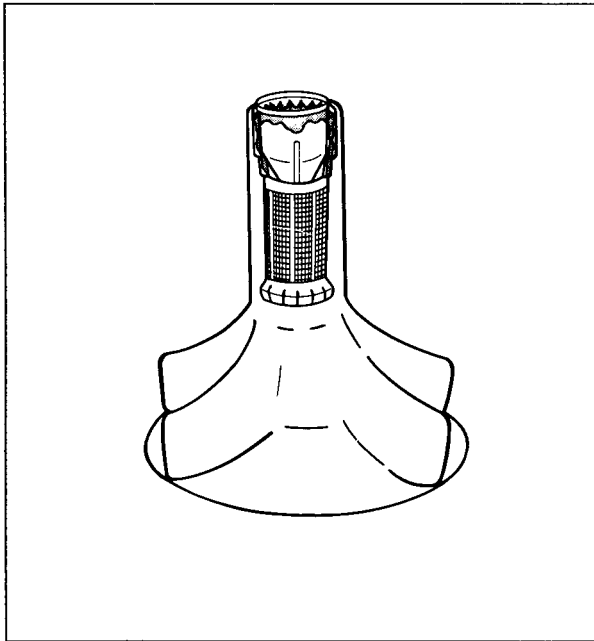

The softener is held in the cap of the agitator by centrifugal force during the remainder of the spin cycle.

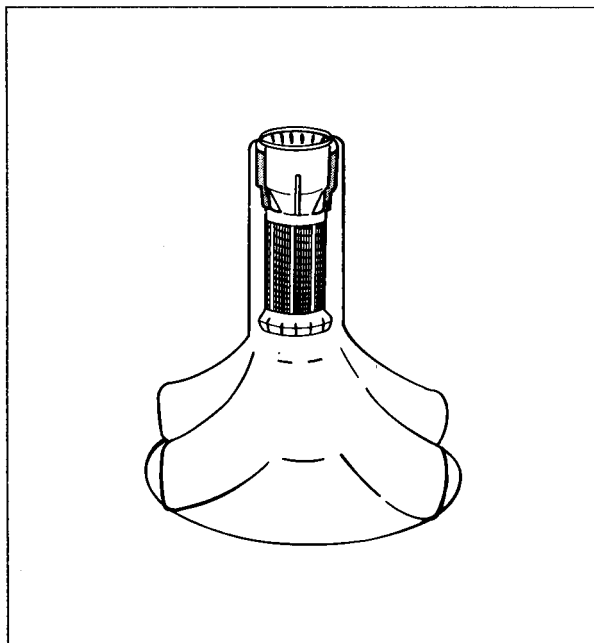

At the end of the spin, the softener drains down through the agitator and into the tub as the water enters for the final rinse.

CAUTION

Do not interrupt the spin cycle when fabric softener is being used. This will cause the softener to be dispensed prematurely and it will not be properly used. This can result in "grease" spots on the clothes.

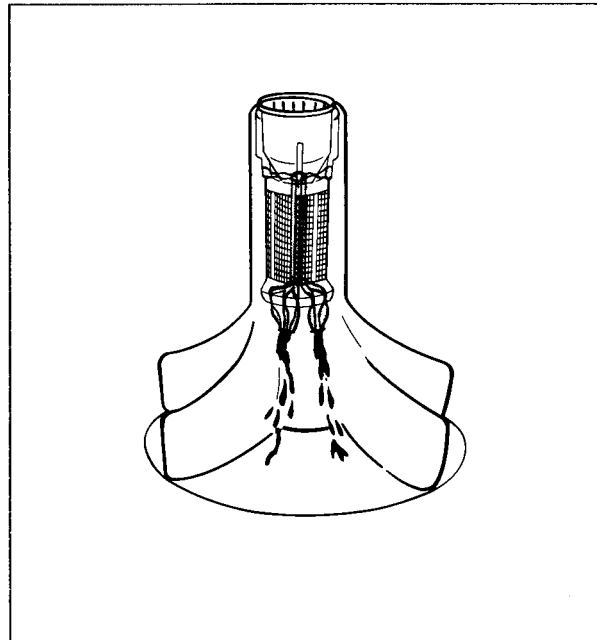

CENTER SHAFT SEAL

This is a water seal that prevents water from getting into the transmission.

To remove seal:

1. Remove agitator. Back screw located on the side of the agitator out far enough to pull agitator off the agitator shaft.
2. Pry out lock ring for retaining washer.
3. Remove retaining washer.



4. remove seal by prying out.

Note: When replacing this seal, the outside should be dry and the inside should be lubricated with center seal grease (56016). Small end of the seal must go against agitator shaft collar.

INNER TUB

To remove inner tub:

1. Remove front panel.
2. Raise top cover.
3. Remove injector tube from tub cover.
4. Loosen tub clamp and remove tub cover.



5. Remove agitator.
6. Use spanner wrench (38313) to remove clamping nut. This is a left-hand thread so it must be turned clockwise. A mallet will be required to loosen the nut. Use care when striking wrench to prevent chipping the tub.



7. Remove clamping nut washer.

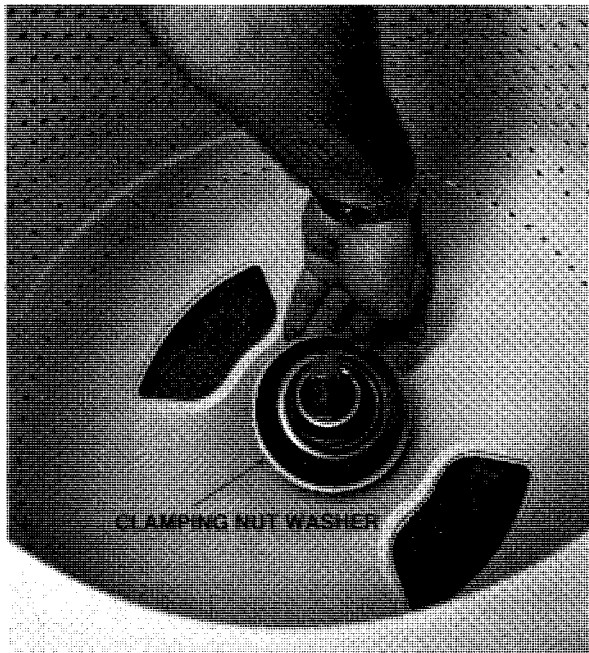

Replacing tub:

1. When replacing the inner tub, rock it back and forth on the mounting stem to make sure it is seated properly.
2. Replace washer and nut.
3. Tighten nut. Use care not to chip tub.

TUB COVER ADJUSTMENT

With the tub cover in place, tighten the clamps just enough to hold the tub cover in place before final tightening. From this point it will probably be necessary to raise the tub cover slightly for final adjustment. Position of the tub cover can be observed with the front panel removed and top cover lowered into position.

When making the final adjustment, the tub cover should be:

1. Adjusted high enough to prevent the inner tub from rubbing against the bottom of the tub cover.
2. Lower top cover and adjust so that the tub cover is as close as possible but does not contact the inner lip of the top cover opening. Be sure the tub cover is raised high enough to provide engagement between the tub cover bracket and unbalance arm. The unbalance bracket on the tub cover should be centered and square to back of the tub. When the tub cover is adjusted correctly, tighten the tub clamps.

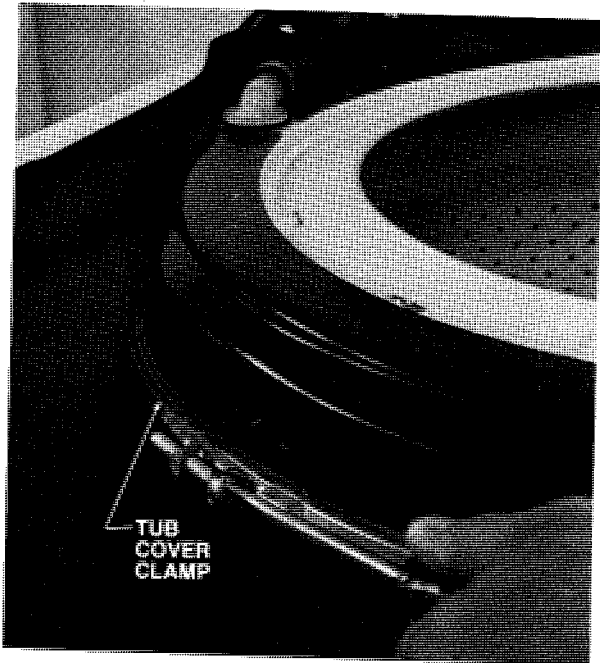

Note: When assembling the tub cover and gasket, be sure all sides of the gasket are clean. Be sure that the triangular rubber gasket is not twisted or outside the clamp. All sides of the gasket are equal and it will make no difference which side is placed against the outer tub and tub cover. Wet the gasket before repositioning between the tub cover and outer tub to aid in the positioning of the top cover.

If it should be necessary to center the tub when it is replaced, use the following procedure.

1. With the front panel removed, place a 1/2 lb. weight in the tub over the counterbalance weight (cover on the transmission). Replace the front panel.
2. Allow the washer to reach full spin speed.
3. When the washer reaches full spin speed, open the lid and allow the tub to come to a complete stop. The opening in the tub cover should be

centered with the opening in the top cover but with a small portion of the tub cover visible at the back. This visible portion of the tub cover should not be more than 1/4".

4. If the proper amount of the tub cover is not visible at the back, or the tub is off center on either side, tighten the opposite damper spring and recheck.

MOUNTING STEM AND BOOT SEAL

To remove:

1. Use an Allen head wrench to remove the set screw in the mounting stem.



2. Use a 38313 spanner wrench to remove the mounting stem. This is a left-hand thread, turn clockwise to remove.

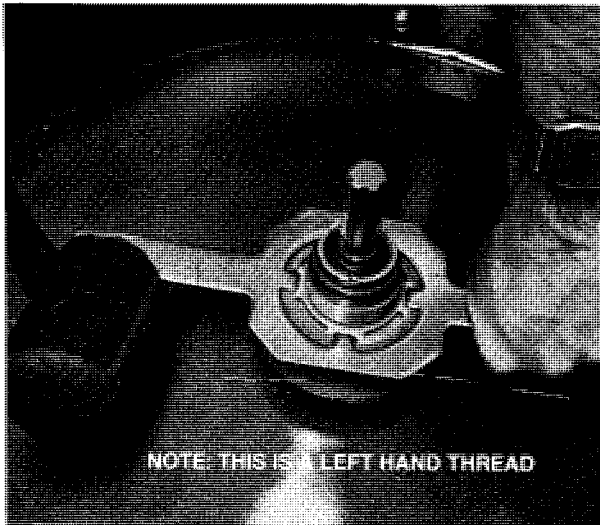

Replacing the boot seal and mounting stem:

1. Wet inside bottom lip of boot seal. Turning clockwise, twist the seal down around the tub flange and seat evenly.
2. Lubricate carbon ring with a thin film of transmission oil (56080).
3. Install mounting stem. Center seal grease (56016) should be used on the mounting stem threads before assembly.
4. When the mounting stem has been hand tightened on the transmission stem, use the spanner wrench to seat the mounting stem. Tap the spanner wrench several times with mallet to seat. NOTE: When tightening the mounting stem, do not over tighten. Specifications call for 20 ft. lbs. of torque as normal and no more than 80 ft. lbs. of torque if additional tightening is required to move set screw position. If you over tighten, there is a chance of distorting the tub bearing sleeve and creating "drag" in spin.
5. Before inserting the set screw into the mounting stem, lubricate the hole in the mounting stem with center seal grease (56016).

When removing the mounting stem, inspect it carefully. If it shows signs of water seepage, we recommend it be replaced.

3. With the mounting stem off, you have access to the boot seal. Remove boot seal by twisting clockwise. Do not grasp around the carbon ring.





In tightening the set screw, two items are important to remember:

A. When the set screw bottoms out, there should be about 2 to 4 threads showing. If not, it is probably in one of the water relief grooves. Do not leave the mounting stem in this position. Remove the set screw and tighten the mounting stem about another 1/8 turn. Replace set screw and check again for exposed threads as above.

B. Do not over tighten the set screw. The recommended method is to first tighten the set screw using the short leg of the Allen wrench in the screw head and the long leg for leverage. This will place a dimple in the stem of the transmission. Then loosen the set screw and tighten again using the short leg for leverage. This will leave the set

screw tight but will not put extra pressure on the upper bearing in the stem of the transmission.

OUTER TUB

To remove outer tub:

1. Loosen clamps and remove drain hose and air dome from outer tub.
2. Remove the three bolts that hold the outer tub to the tub braces. In removing the tub bolts, remove outside nuts (prevent turning of the bolt to avoid damaging the seal washer on the bolt), lock and rectangular washers. Push tub bolts into the tub.

Note location of seal bolt, tub, fiber washer, brace, rectangular washer, lock washer and nut.

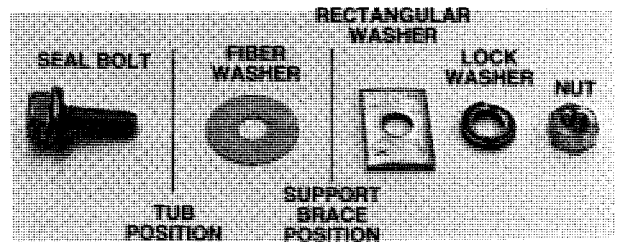

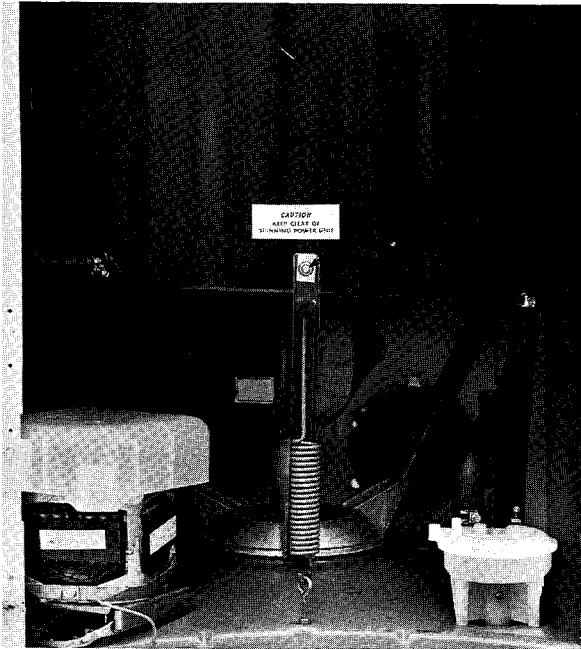

When tightening the assembly, turn the nut on the outside of the tub brace while holding head of the seal bolt with wrench. Tightening by turning the seal bolt from the inside may damage the seal.

Note: If you have a washer that is leaking water around one of the tub nuts, the leak can sometimes be stopped by tightening the tub nut without removing the inner tub.

1. Front tub nut. This nut may be tightened by removing the front panel and placing a 1/2" box end wrench on the tub nut. To prevent damaging the seal, hold the end of the bolt with a vice grip while the nut is being turned. It may be necessary to cut a slot in the end of the bolt

and hold the bolt with a screw driver.

2. Left and right tub nuts. To gain access to these nuts, remove the front panel and raise the top cover. Follow the procedure for tightening the front tub nut.

To remove outer tub bearing:

1. Because of the porcelain tub and molded retainer, it is not practical to drive the tub bearing from the tub. To remove the bearing from the tub, elevate the tub so that the porcelain drain spout clears the floor. This can be done by placing 2 x 4's under the tub.
2. Apply pressure on the bearing, pushing it from the tub. This can be done by stepping on the bearing.

To replace the tub bearing:

1. Turn the tub over and start bearing into bottom of the tub.

Note: Caution should be exercised to see that the tub bearing is started into the tub straight to prevent an erratic egg shaping when seated in the tub.

2. Press bearing into place by applying pressure. This may also be done by standing on the bearing. To avoid betting dirt in the bearing, place a protective cloth over the bearing before standing on it.

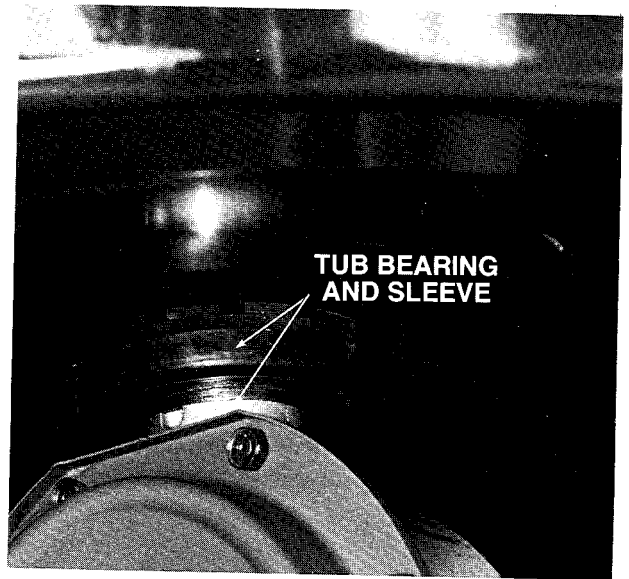
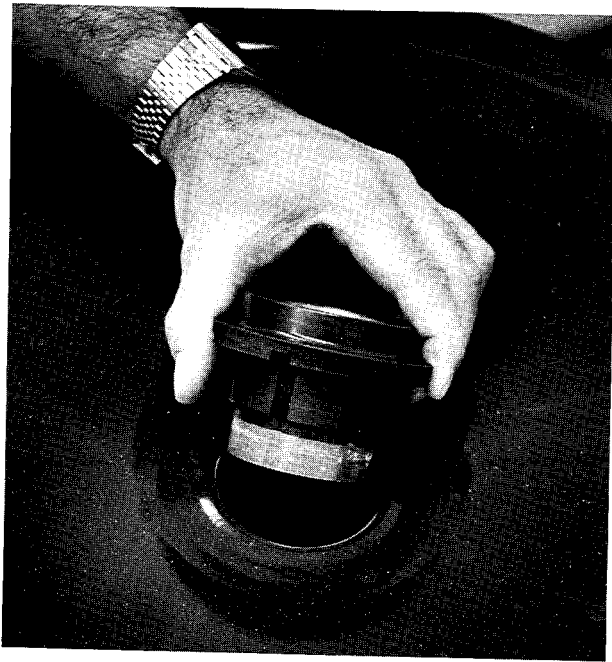

SEAL LEAKS

Water leaks from the center shaft seal or boot seal can be detected by looking under the outer tub with a flashlight. When looking under the outer tub you will be able to see the bottom of the tub bearing and the bottom of the tub bearing sleeve where it sits on top of the transmission.

If the water is coming from the slots in the tub bearing, suspect a boot seal leak.

If the water is coming out underneath the bearing sleeve and down onto the transmission, suspect a center shaft seal leak or mounting stem set screw leak.

TRANSMISSION

How it works:

The helical drive mechanism used on the washer is simple—not requiring a special device or linkage normally used to shift the washer from agitation to spin.

As you look at the following drawings, remember that the parts shown in dark (damper, brake housing, brake drum and outer race of the spin bearing) are attached to the base and never rotate.

A reversible motor, helical (threaded) drive shaft and pulley make up the drive mechanism. The pulley, threaded onto the helical drive shaft, moves either up or down the shaft dependent on the direction it is turned by the drive motor through a drive belt.

AGITATION

With the pulley (A) being turned clockwise as shown in Drawing 1, it moves down the helical drive shaft (B). As it rotates down the shaft, a lug (C) on the pulley comes against drive lug (D) which is splined to the helical drive shaft.

At this point the drive shaft rotates with the pulley. The pulley bearing (E) which is sitting on top of the pulley, rotates with the pulley, drive lug and drive shaft.

Inside the transmission, the pinion gear, splined to the drive shaft, rotates and drives the bevel gear. As the bevel gear rotates, the torque block and yoke assembly causes the agitator shaft to oscillate, creating the water action for wash.

AGITATION

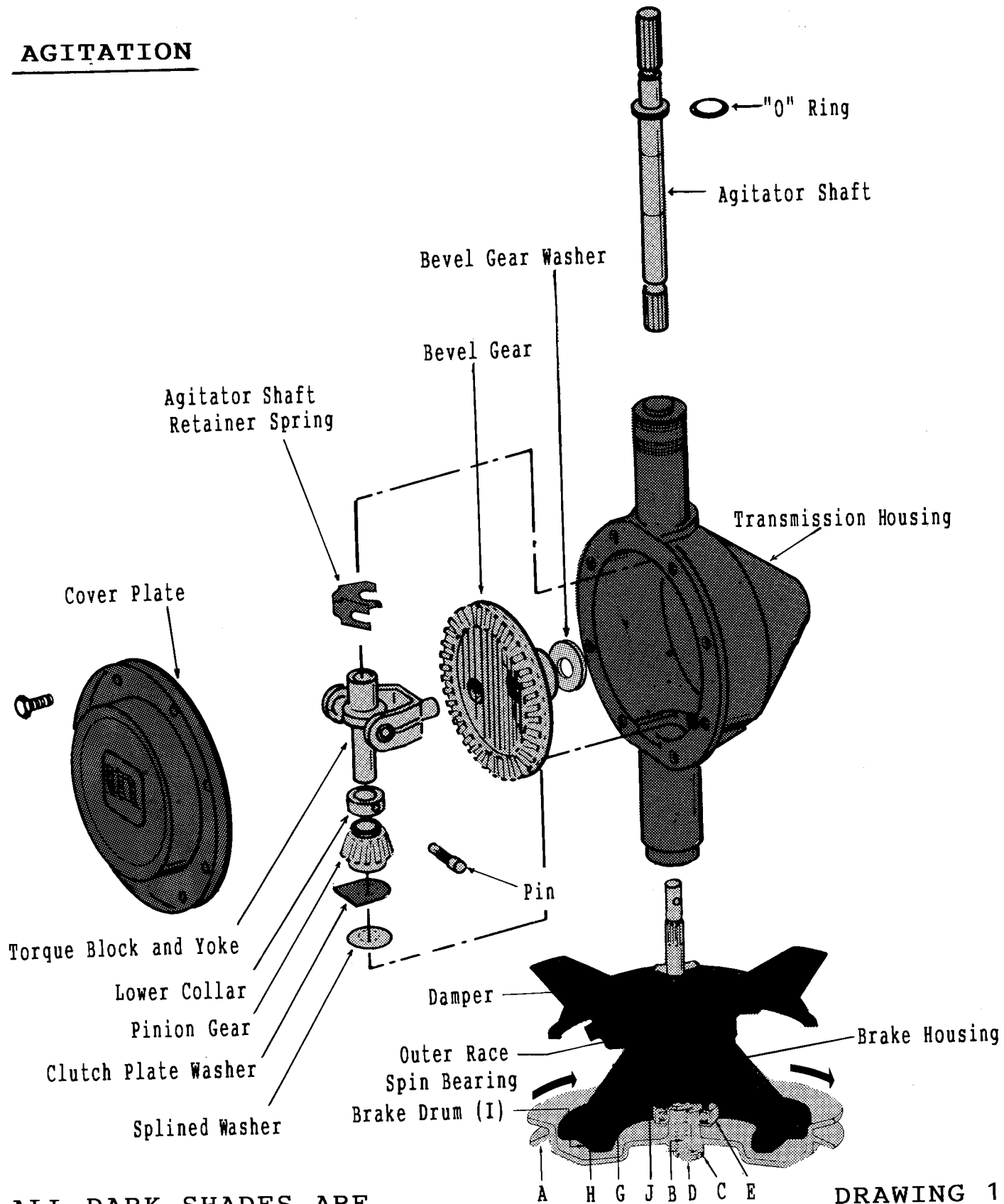

DRAWING 1

**ALL DARK SHADES ARE
STATIONARY COMPONENTS;
ALL LIGHT SHADES ARE
MOVING COMPONENTS**

SPIN

When the motor reverses, the pulley will turn in the direction shown in Drawing 2. This causes the pulley (A) and bearing (E) to turn. The pulley climbs the threads on the helical drive shaft (B) overcoming the force of the brake spring (J) and lifts the brake rotor (G) and brake shoe off the brake drum (I).

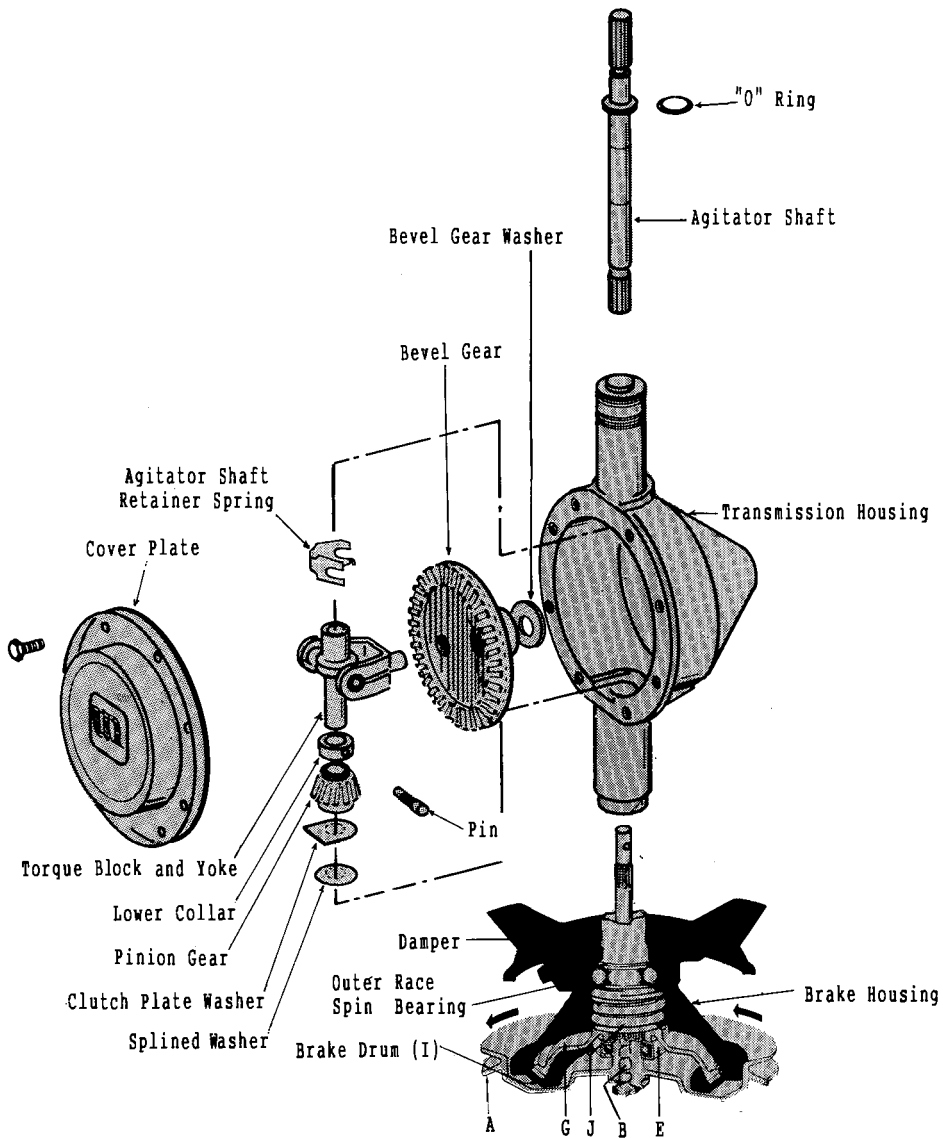

ALL DARK SHADES ARE
STATIONARY COMPONENTS;
ALL LIGHT SHADES ARE
MOVING COMPONENTS.

DRAWING 2

As the pulley climbs the shaft and overcomes the force of the brake spring there is a downward pull on the shaft.

Inside the transmission are two washers that act as a clutch. This friction clutch consists of the bronze washer and clutch plate washer. The bronze washer is splined to, and rotates with the drive shaft. Between the bronze washer and the pinion gear is the clutch plate washer. It fits into a "D" slot in the housing, which keeps it from turning.

As the helical shaft is pulled downward the two clutch washers under the pinion are forced together. This is done rapidly and slippage occurs only during the first two or three revolutions, until the film of oil between the two clutch washers is forced out.

The drive occurs when the washers are forced together and pulley has climbed the shaft as far as it can. The driving force has locked the pulley, brake rotor and transmission together. All will turn as a unit in the same direction as the pulley is turning, causing the tub to spin (counterclockwise viewed from the top).

momentum of the spinning tub drives the pulley downward allowing the brake spring to press the brake rotor down. The rotor presses the oil in the lip of the brake drum out of the way and contacts the drum surface and stops the tub.

Replacement of the internal transmission components can be done without removing the transmission from the washer. Therefore, you will no longer replace the entire transmission assembly. Any internal component that fails must be replaced as needed.

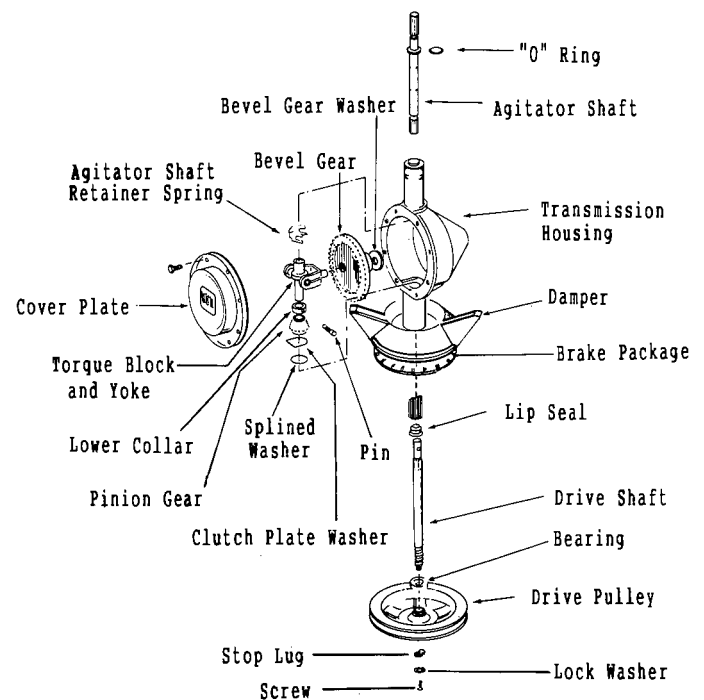

TRANSMISSION REPAIR PROCEDURE

1. Disconnect water hoses and power supply. Loosen the set screw in in the agitator and remove the agitator.

SPIN CYCLE COMPLETED

When the washer reaches the end of the spin cycle, the driving force is removed. Thus, there is no force supplied to lock the components together or compress the brake spring. The

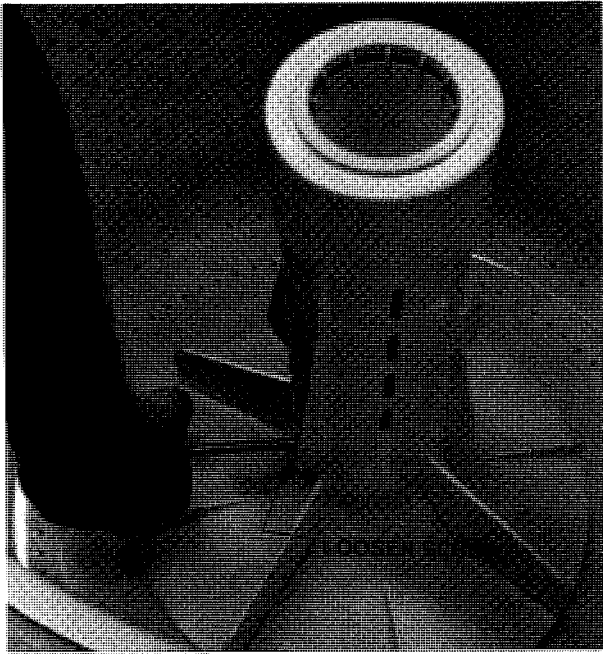

2. Remove the lock ring, retaining washer and center shaft seal.

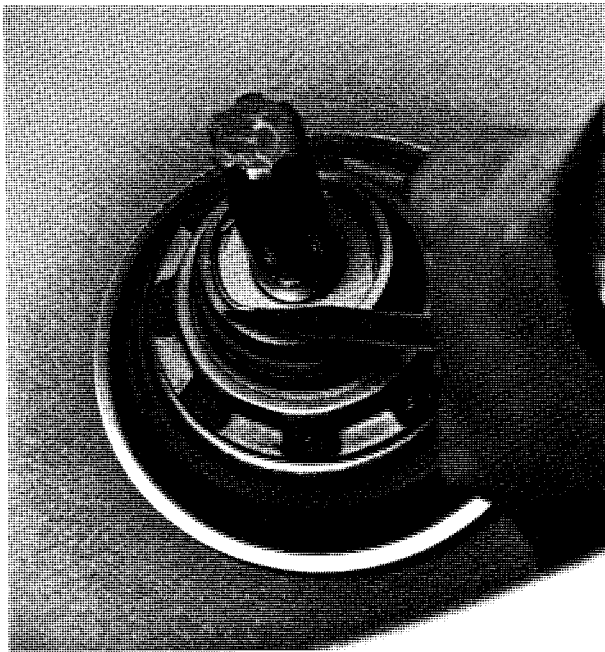

3. Place the tub block in the tub.

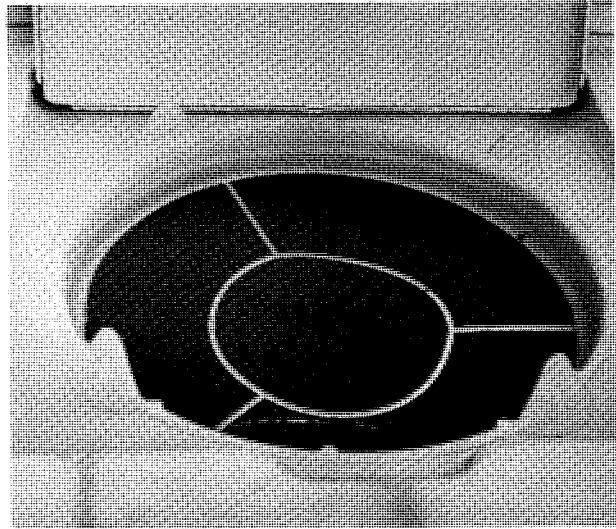

4. Remove the front panel.
5. Lay the washer on its back and remove both belts.
6. Place an oil catch pan under the transmission.
7. Remove the eight (8) hex head bolts with a 7/16 nut driver. Make sure the bolt heads are facing up. This will ensure that you will not get oil all over the back of the washer if the cover should come off.

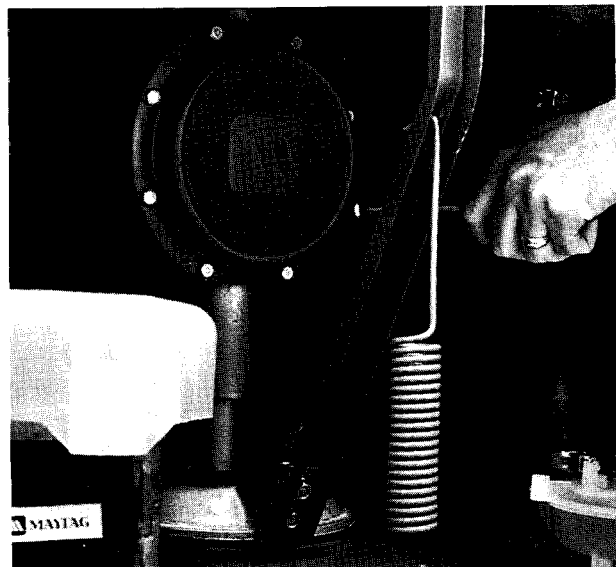

8. Remove the cover plate (it may be necessary to pry the plate off with a putty knife). Carefully rotate the transmission to dump the oil into the catch pan.
9. Remove the agitator shaft retaining spring by compressing it and lifting it off the agitator shaft.

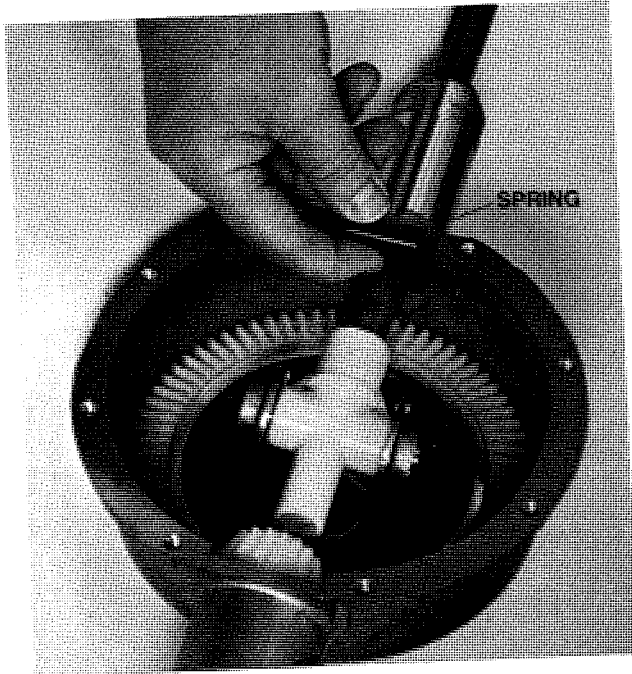

10. Remove the lower collar pin with an Allen wrench.

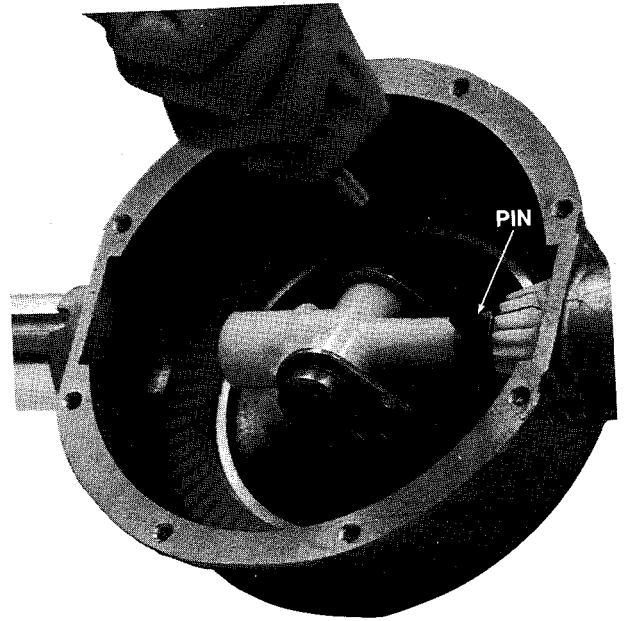

11. Grasp the drive pulley and slowly pull the center shaft out (only a small amount of force will be needed to move the shaft). The center shaft only needs to be pulled out far enough to allow removal of the internal components. Be careful not to damage the lip seal at the bottom of the transmission.
12. Pull the agitator shaft out far enough to allow for the removal of the internal components.
13. With the agitator and drive shafts backed out, lift out the following parts: lower collar, pinion gear and clutch plate and spline washers. The washers are located behind the pinion gear.

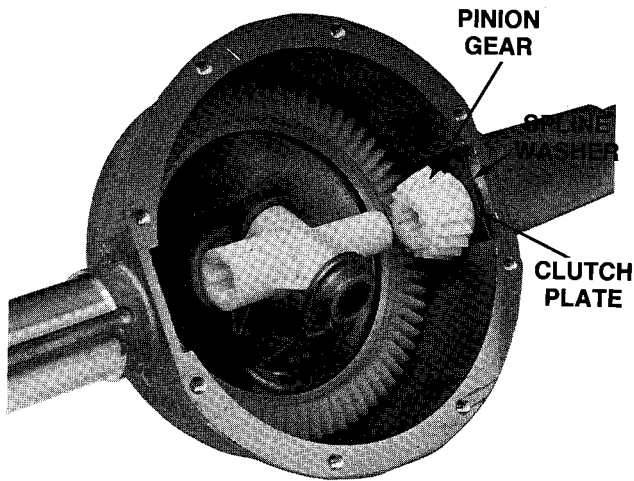

mission. Clean any silastic from the transmission housing and cover plate before assembly. The gasket face on the transmission and the cover plate must be free of oil.

ASSEMBLY PROCEDURE

1. Install the bevel gear washer. Coat the stud pin with transmission oil (56080). Replace the bevel gear.

14. The torque block and yoke assembly and bevel gear can now be removed. Underneath the bevel gear is the bevel gear washer, remove it also.

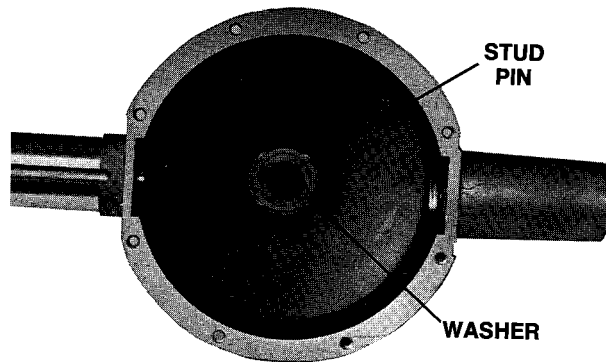
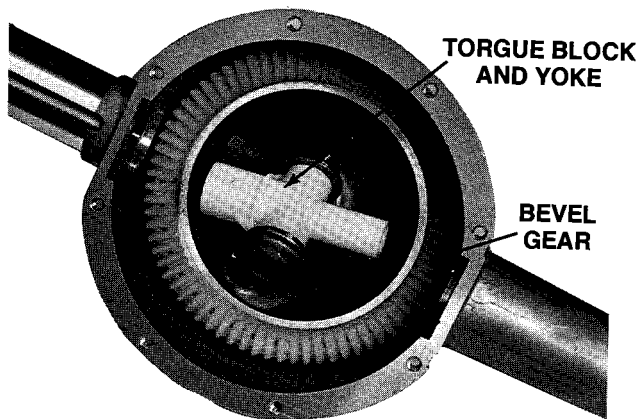

2. Coat the angle hole of the bevel gear with transmission oil (56080). Place the stud pin of the torque block and yoke assembly into the angle hole in the bevel gear. Point the unsplined end of the yoke toward the bottom of the washer.

15. Clean all components that are to be assembled back into the trans-

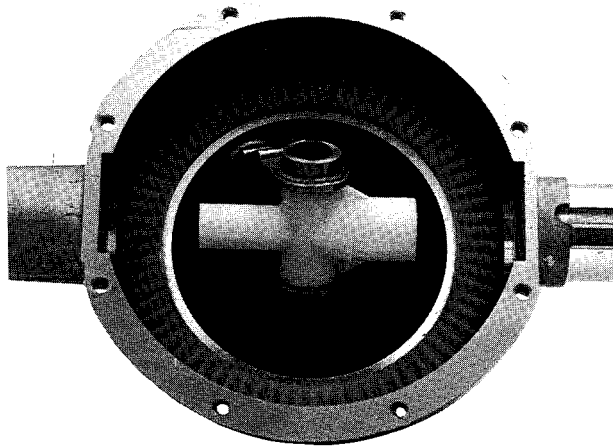

3. Place the spline washer on the bottom and clutch plate washer on top and place them in the "D" slot as shown.

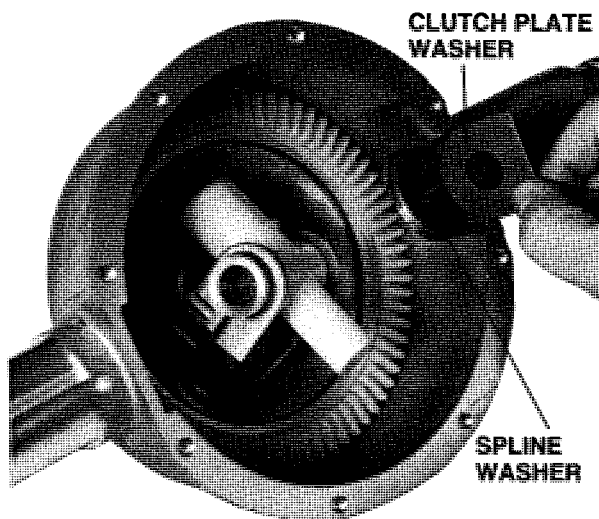

shaft through the various components until it is flush with the pinion gear. To get the drive shaft through the splines on the spline washer and pinion gear, twist and push on the drive shaft while pushing the pinion gear back against the washers.

5. Place the lower collar between the pinion gear and torque block and yoke assembly. Push the shaft into the torque block and yoke assembly.
6. Install the pin for the lower collar and tighten. This has to be tight to prevent it from coming loose.

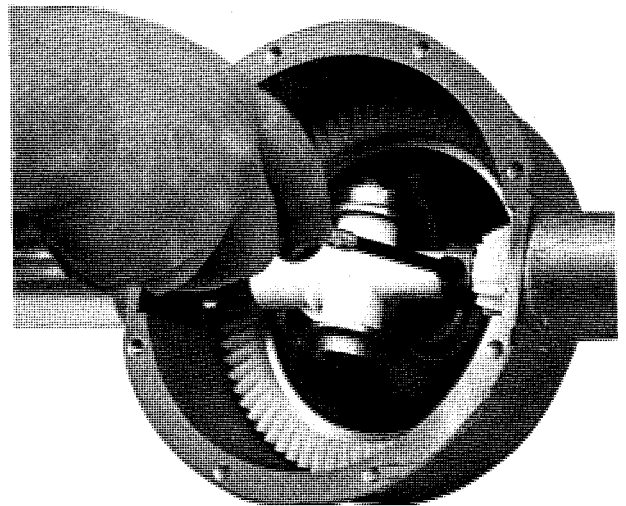

7. Push the agitator shaft into the splined end of the torque block and yoke assembly. Make sure the "O" ring is in place. It may be easier to remove the "O" ring before and install after agitator shaft is pushed into place.

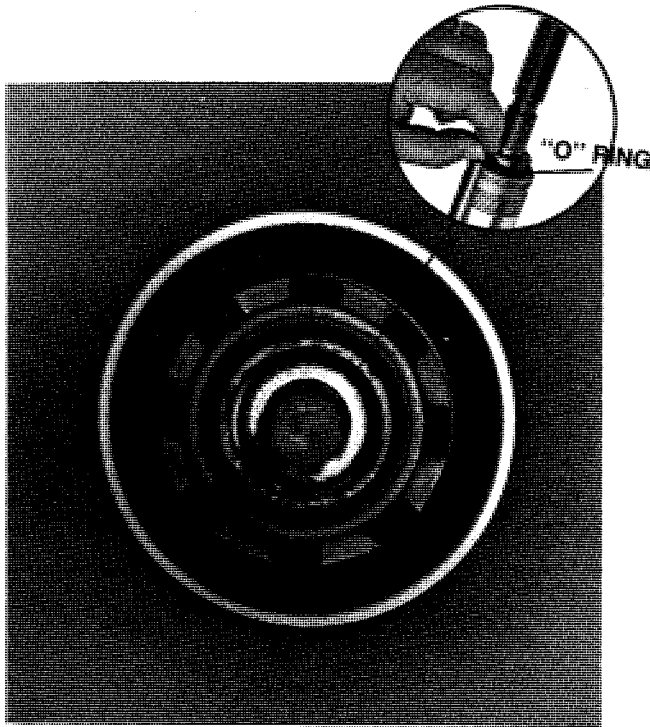

housing. Fill with transmission oil (56080).

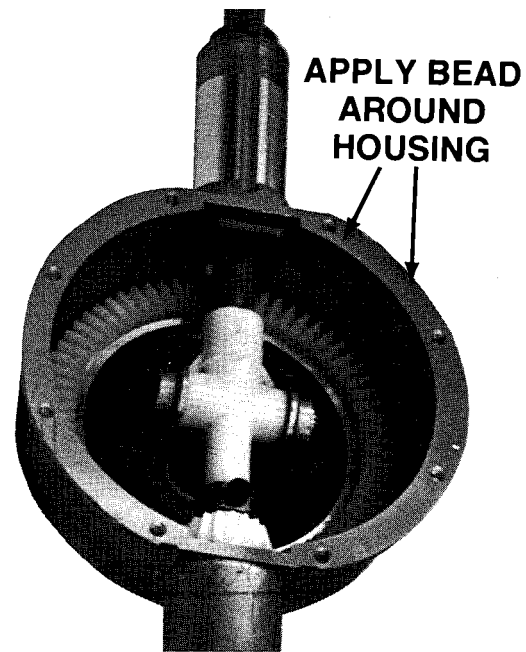

8. Place the agitator shaft spring into the undercut on the agitator shaft (compress the spring together before inserting).

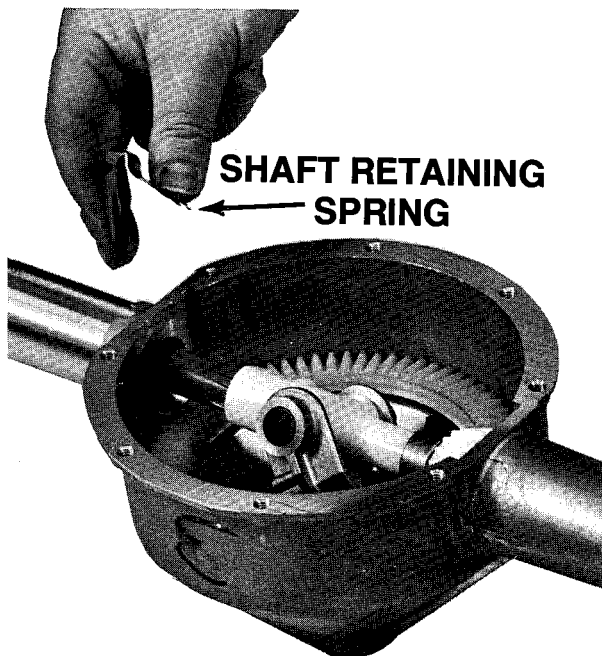

9. Rotate the drive pulley counterclockwise to check the transmission for proper operation.
10. Apply a bead of silastic to the gasket face of the transmission

11. Place the cover plate on the housing. Insert the eight bolts and tighten.
12. Replace the belts. Place washer in upright position. Replace the front panel and remove the tub block.
13. Install the center seal, retaining washer and lock ring into the mounting stem.
14. Replace agitator and tighten set screw.
15. Check washer for proper operation.

LIP SEAL

A lip seal is used to keep the oil in the transmission. It is located at the bottom of the transmission and is pressed into a bore in the center tube. The center shaft is inserted through the

seal. The lip of the seal presses against the center shaft creating a seal to keep the oil inside the transmission.

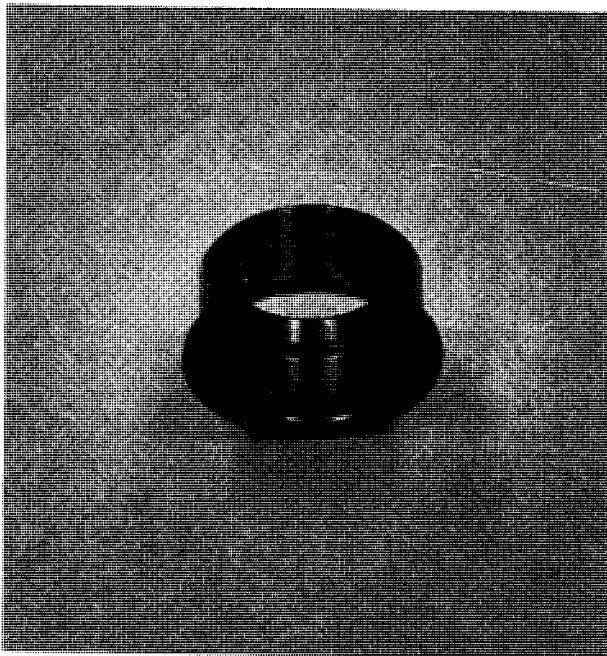

Removing the seal:

1. Disconnect power supply.
2. Insert tub block, remove front panel and tilt washer back.
3. Remove both belts, drive pulley and brake package (refer to section on brake package removal). The brake package needs to be removed to make sure the lip seal is pressed all the way into the center tube and to prevent any solvent from getting into the brake package when cleaning the lip seal bore.

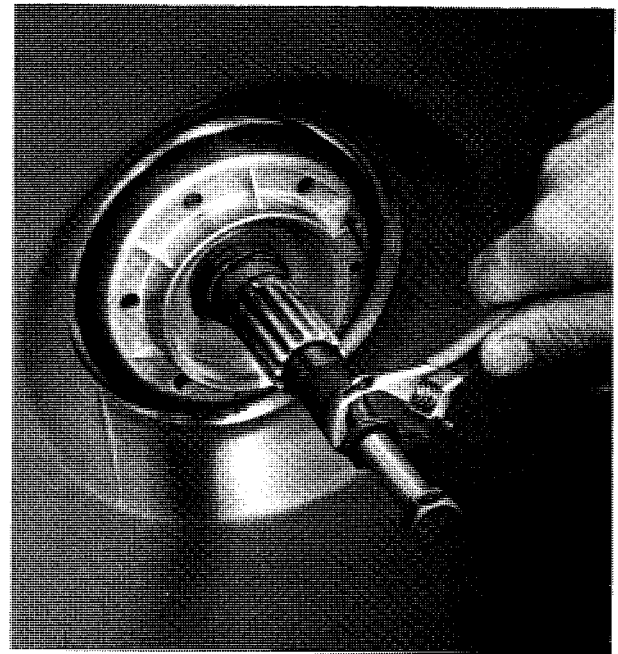

4. Use the lip seal tool (38228) to remove the lip seal from the center tube. This tool is screwed into the lip seal and the lip seal is removed by turning the bolt against the center shaft. NOTE: You may need to hold the transmission when tightening the lip seal tool and when replacing the lip seal to keep the transmission from rotating.
5. Clean lip seal bore in the center tube with CDL (2-04210) to remove any oil. Make sure area is clean and dry.
6. Press new lip seal over Seal-Protector. The Seal-Protector is designed to protect the seal area of the lip seal from rolling over or tearing as the seal is pressed into the center tube of the transmission.
7. Slide assembly over square thread of center shaft until the lip seal starts into the center tube bore.

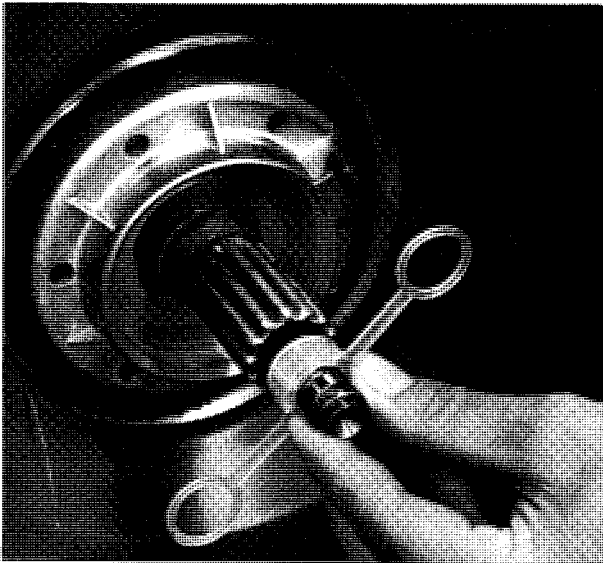

8. Turn drive pulley onto the center shaft and against Seal-Protector. Tighten pulley to press lip seal into center tube bore. Back pulley off and check to make sure lip seal is pressed into position (flange of lip seal should be against end of center tube).

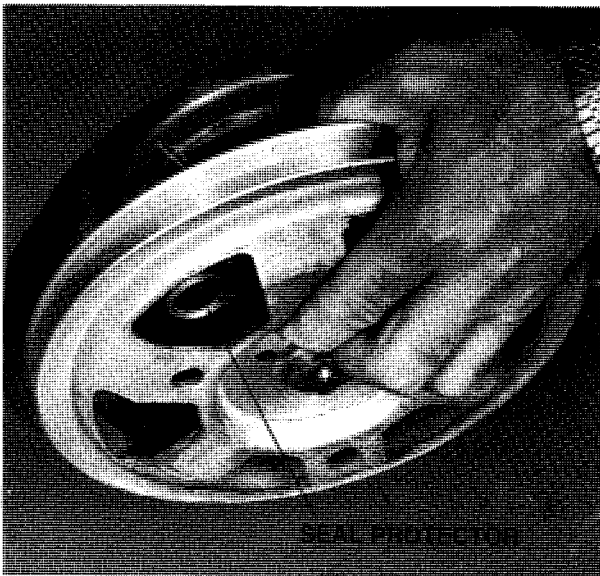

9. Remove pulley.
10. Using the loops, remove Seal-Protector and discard.
11. Replace brake package, pulley and belts.
12. Place washer in upright position. Replace front panel and remove tub block. Connect washer and check for proper operation.

DRIVE PULLEY AND ROTOR BEARING

The drive pulley must be removed to gain access to the rotor bearing or to remove the brake package.

To remove the pulley:

1. Remove drive and pump belt and rubber cap covering hub of pulley.
2. Remove screw and washer from bottom of the drive shaft.
3. Remove the splined drive lug from the drive shaft.
4. Rotate pulley counterclockwise to remove it from the helical shaft. The rotor bearing is located on top of pulley.

Note: When the drive pulley is replaced the drive lug must be properly positioned.



DRIVE LUG ADJUSTMENT

To set the drive lug:

1. Place rotor bearing on drive pulley with cupped side down over hub of pulley.
2. Turn the drive pulley onto the shaft and rotate it up as tight as you can (you may have to hold the transmission in the brake rotor). This will bottom out the transmission in the brake rotor. Note position of lug on drive pulley hub.
3. Install the drive lug on the end of the drive shaft directly across from the pulley lug (180 degrees) with the pulley still run up tight. One side of the drive lug is flat compared to the other side. Flat side should be toward the pulley.
4. Release the pulley and let it rotate down against the drive lug.
5. Now rotate the pulley back up the drive shaft until you meet resistance. Check the positions of the drive lug and pulley lug. Wherever

the pulley lug ends, consider this to be the 12 o'clock position. The drive lug should be at the 9 o'clock position. If not, reposition the drive lug with the pulley in position where it meets resistance. In this position the two lugs should have about 1/4" to 3/8" space between them.

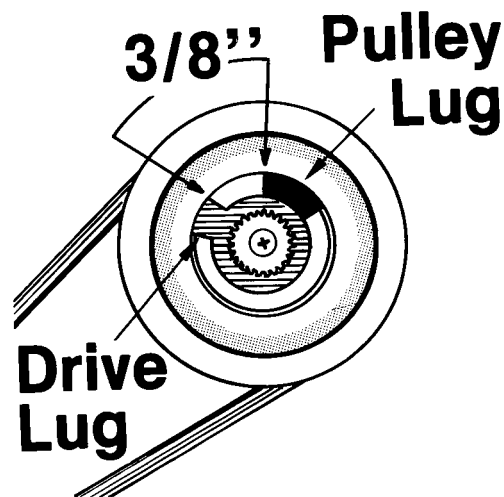

CAUTION

There should always be a clearance between the bottom of the pulley and the top of the drive lug to prevent the drive pulley from dragging on the drive lug, forcing it off the shaft.

BELTS

Replacing belts:

The belts can be replaced using two different methods. One method is tilting the washer back and replacing the belts. The other is by removing the

front panel and using the access hole in the base frame. The access hole is put in the base frame in the event the washer cannot be tilted back.

To change the belts using the access hole:

1. Remove front panel.
2. Grasp the drive belt at the end that goes on the motor pulley. Squeeze this end together. This will form a loop on the other end. Insert belt under washer with the loop end towards the drive pulley.

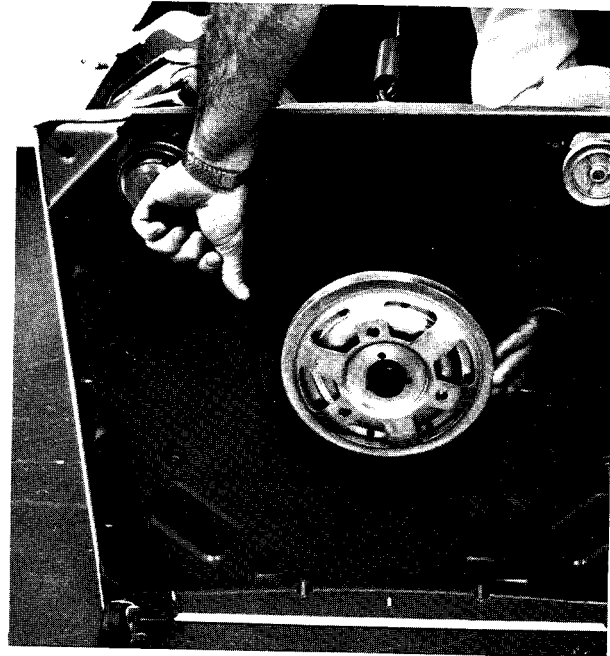

3. Stick your hand through the access hole and guide the belt around the drive pulley.

4. Push motor towards transmission. Loop belt over motor pulley and rotate it into position
5. Replace pump belt and check the pump belt tension (refer to section covering adjustment for pump belt tension).
6. Replace front panel and check operation of the washer.

BRAKE PACKAGE AND RADIAL BEARING

DRY BRAKE:

The normal symptom of a dry brake package is a screeching noise at the end of the spin cycle as the tub comes to a stop. The brake can be lubricated without removing it from the washer.

To lubricate brake:

1. Place tub block in tub and lay washer back far enough to get to the pulley and brake.
2. Block front leg to prevent washer from falling.

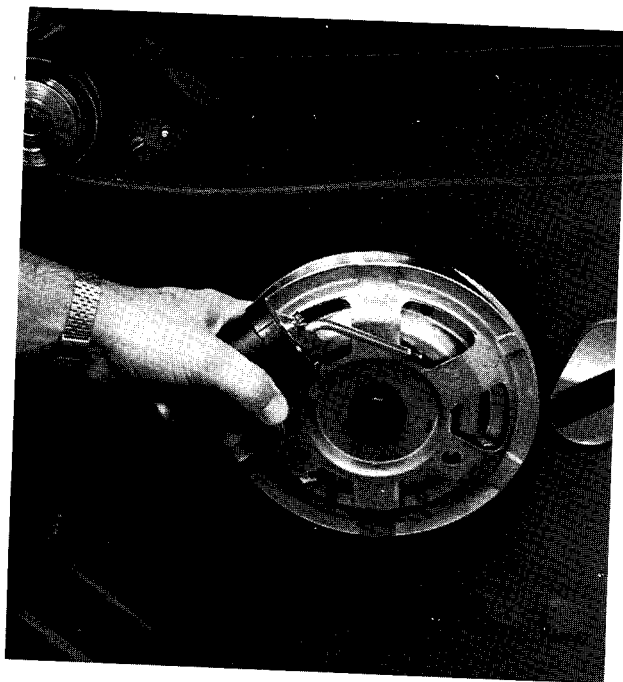

3. Squirt about one tablespoon of transmission oil (56080) over lip of the brake package. An oil squirt can works well (or take pulley off).

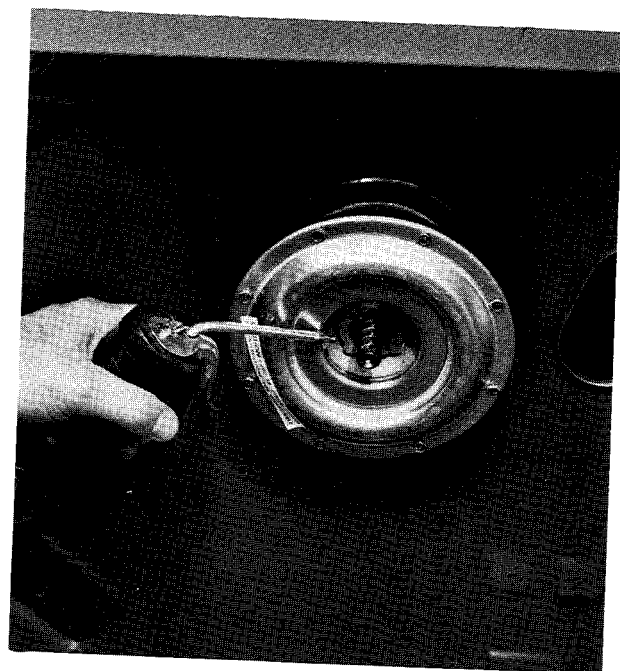

4. Turn the pulley on the shaft until the brake is disengaged. With the brake disengaged, the oil will run under the brake lining. Turn the pulley several times to ensure proper lubrication.

Brake package removal:

After the drive pulley has been removed, the brake assembly can be removed as follows (transmission in place).

1. With tub block in place, the tubs and transmission will be parallel with the cabinet. Remove hex bolt and retainer clip in damper holding the brake package.

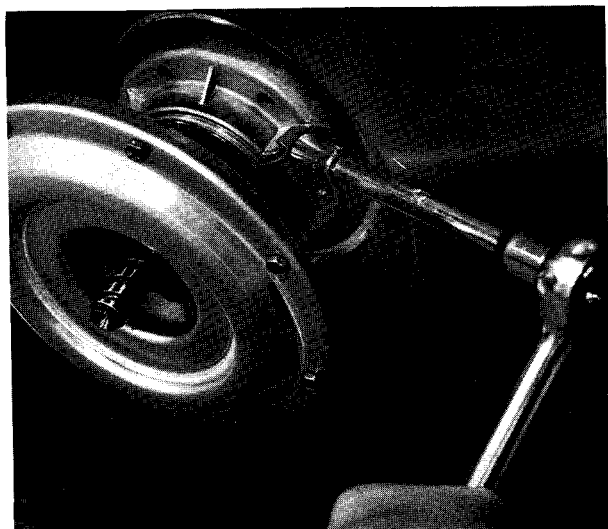

2. Use the 38315 special tool and hammer to unscrew the brake package assembly from the damper. The lugs on the tool should be against the lugs on the brake package and not against any of the screws. Brake package is removed in a counterclockwise direction. When the brake package is free, pull out to disengage it from the spline on the center tube of the transmission.

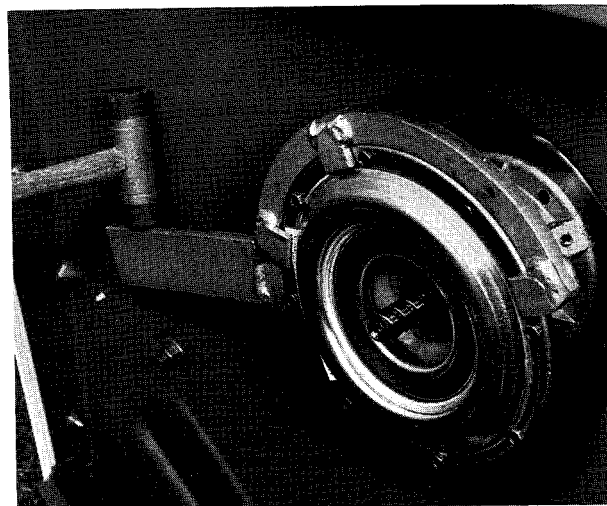

3. After brake package has been removed, the radial bearing may be removed from the top of the brake package by tapping on side of the brake package.

WARNING

THE BRAKE ASSEMBLY CONTAINS A SPRING WHICH IS PARTIALLY COMPRESSED AND EXERTING 200 LBS. PRESSURE. BECAUSE OF THIS SPRING, CAUTION MUST BE TAKEN WHEN DISASSEMBLING THE UNITS.

DAMPER AREA SERVICE

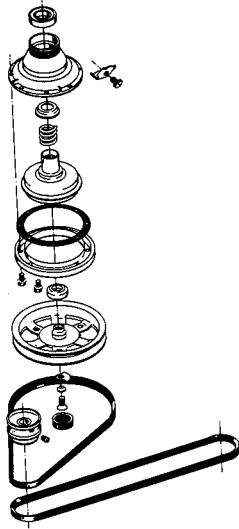

To replace the brake package:

1. Place radial bearing in top of brake package.
2. Use a coating of center seal grease (56016) to protect bearing from water.
3. Insert brake package onto center tube splines.
4. Start threads of brake package into damper by hand. This will not be easy because you have to lift the tub and transmission.
5. Make sure tub block is in place to keep tubs level and prevent binding on brake package threads.
6. When turning brake package into the damper, allow the transmission to rotate so that you do not have to overcome the friction of the brake.
7. When tight, use special tool (38315) and hammer to seat brake package strongly in place.
8. Replace retainer clip and tighten bolt securely into damper.

To replace or lubricate damper pads:

1. Remove two screws holding front panel and remove front panel.
2. Remove two bolts holding top cover and raise top cover.

Note: Tape lid to prevent it from striking the control panel.

3. Remove nuts from three eyebolts. The position of the nuts on the eyebolts can be marked by placing strips of electrical tape around bolts above nuts before loosening.
4. Remove drive belt.
5. Tip washer back and lay a 4" X 4" wood block under drive pulley.
6. Set washer down on top of the wood block.

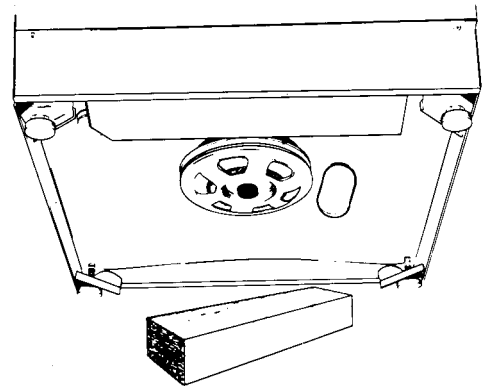

7. The complete assembly of the tubs and damper should be pushed up

from the base far enough to get to the damper pads.

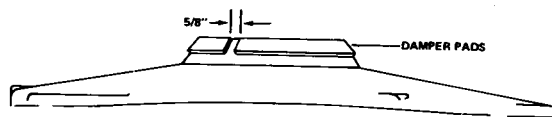
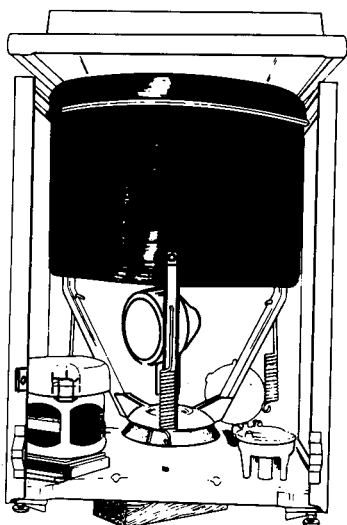

8. Scrape old pads from base.
9. Use a degreasing agent such as alcohol to remove any grease from area.
10. Apply rubber adhesive (55978) to area where old pads were removed.
11. Apply pads to base and let dry. The top surface of pad should be located $3/32$ " below center opening in base. The distance between pads should be about $5/8$ ".

12. Lubricate damper pads with silicone grease (2-04999).
13. Assemble washer.
14. Check tub centering and adjust if necessary (refer to section on tub centering).

DAMPER REPLACEMENT

If damper replacement is needed:

1. Remove front panel.
2. Remove all hoses from outer tub.
3. Remove injector tube from tub cover.
4. Lay washer on its back (watch the lid).
5. Remove belts, pulley and brake package.
6. Place washer in an upright position and remove nuts from centering springs (mark location).
7. Lift entire assembly, tubs, transmission and damper, out of the

washer and lay on the floor. Use caution when doing this.

8. Remove the bolts from the damper ears that hold the tub braces.
9. Lift damper clear of the tub braces and remove from washer.
10. Install new damper using reverse order. Make sure boss for retainer clip is aligned toward pump.

POLY PUMP

The poly pump serves a dual purpose. It holds the water in the tub during agitation and pumps the water out of the tub to the drain during spin.

On Suds Saver models it can either pump the water out to the drain/storage tank or return the water from the storage tank back into the tub. Direction of the pump impeller is dependent on the direction of the motor since the pump is belt driven from the motor.

To remove the pump:

1. Remove front panel.

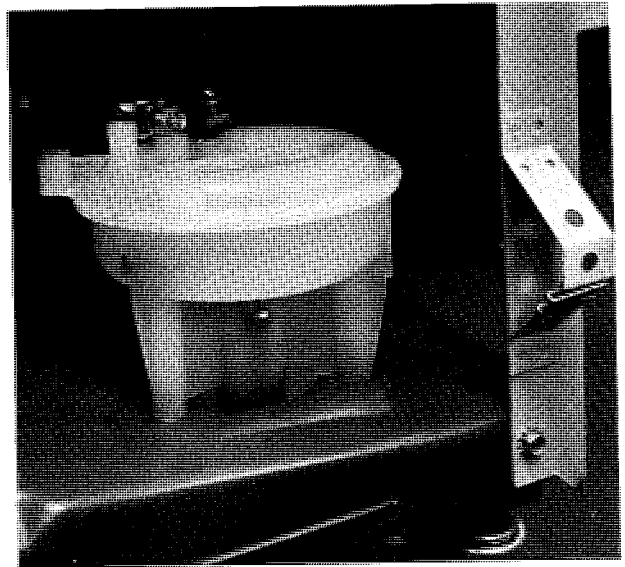

2. Disconnect hoses from pump and remove pump belt.
3. Remove the three screws from bottom of base holding pump to base. The mounting holes in the base are slotted for adjustment of the pump belt. Note general position of pump before removing.
4. Lift pump through hole in base.

Pump belt adjustment:

1. With washer in an upright position, pull motor ahead so drive belt is tight.
2. Grasp pump belt in the middle and flex. With the belt flexed, there should be approximately 1/4" between the inside surfaces of the pump belt.

WATER VALVE

The following is an explanation of the operation of the water valve and points out the importance of the filter screens.

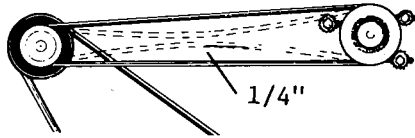

GOES AHEAD OF "SCREWS ON PUMP"

3. If necessary, loosen screws holding pump and position pump to get the 1/4" dimension.

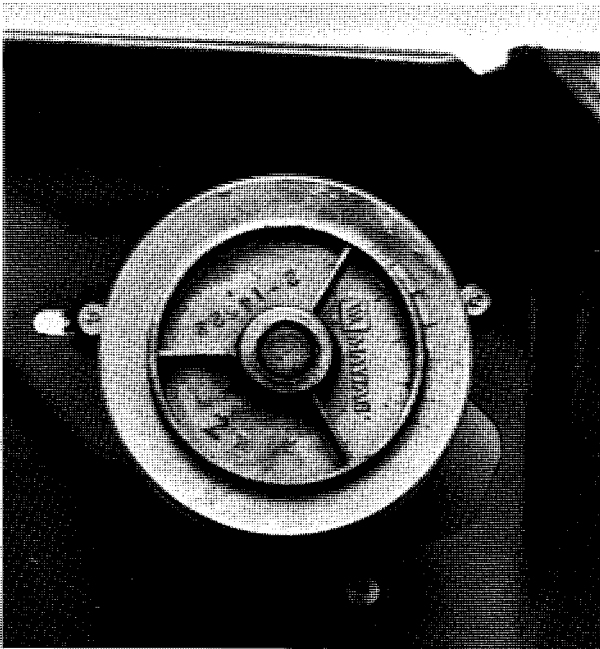

4. Replace front panel and check operation of the washer.

Filter screens must be used in the inlets of the water valve to minimize unnecessary valve failures. These screens are used in the valve inlets to prevent foreign materials from entering the valve. Particles of sand, soil or mineral deposits gathering in the valve can block the diaphragm "open" or hinder solenoid plunger operation.

WATER FLOW

The water valve used on automatic washers is designed to operate in a pressure range of 30 to 120 p.s.i. If for example, the water pressure at the inlet valve is 40 p.s.i., water from inlet "A" is pushing against diaphragm "C" at 40 p.s.i. The solenoid plunger "E" and spring "F" alone are not strong enough to keep the diaphragm in a closed position, blocking the flow of water until the solenoid is energized. To do this, small bleed holes "D" about the size of a pin, are put in the diaphragm to allow water to flow into the plunger area "H". The water in the plunger area equalizes the pressure on both sides of the diaphragm. The spring pushes the plunger down into the center of the diaphragm closing the center opening, until the solenoid is energized.

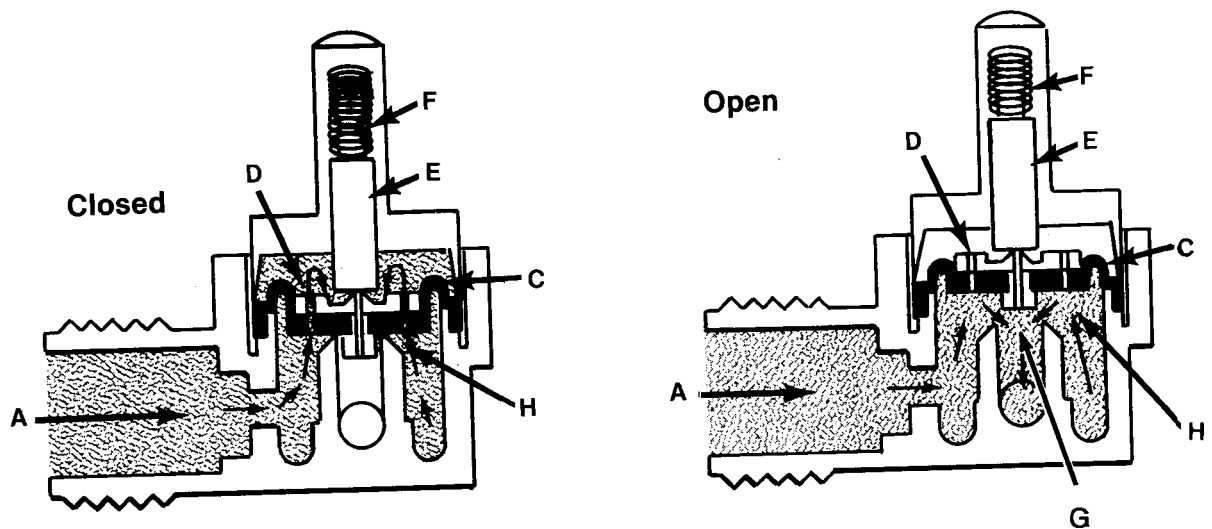

During the fill portion of the cycle, the solenoid is energized, creating an electromagnetic field and pulling the plunger "E" away from the diaphragm. This allows water to escape out the opening "G", thus having little pressure in the plunger area. The water pressure from the supply forces the diaphragm "C" open and allows water to run under the diaphragm and out the outlet of the valve and into the washer. When the washer fills to selected water level, the solenoid is de-energized and plunger spring "F" pushes the plunger back into the diaphragm opening "G". Water is forced through the bleed holes "D" until an equal pressure is attained on both sides of the diaphragm thus stopping the flow of water to the washer.

Assume for a moment the solenoid is energized and the washer is filling. If a foreign particle reaches the water valve "A" and there are no screens to stop the particle, it goes on into the valve to the diaphragm "C" and the particle lodges in the small bleed hole. This permits the water to continue to flow under the diaphragm, to the outlet and into the tub, because the water cannot pass through the bleed hole to equalize pressure on both sides of the diaphragm to close the diaphragm seat.

INLET HOSE SCREENS

Both inlet hoses have screens to help filter out the foreign material that may come from the water source. A fine mesh screen is used in the water valve inlet to filter out the material that may pass through the inlet hose screen. Always check both inlet hose and valve screens.

Knowing how the valve operates you can see what happens if the valve inlet screens were removed. A piece of sand, rust from the plumbing or any foreign material entering the valve could block the bleed hole(s) "D" in the diaphragm.

If filter screens have been removed, make sure screens are replaced to minimize unnecessary valve failure.

Water valve removal:

1. Disconnect washer from power supply
2. Shut off both hot and cold water faucets.
3. Move washer away from wall. Remove both hoses, catching excess water in a pan.
4. Remove the 5/16" screw that holds the bracket to the cabinet. Lift the bracket and pull away from washer.
5. Loosen the clamp and remove the hose from the valve. There will be some water, catch in a pan.
6. Note wire colors on the valve terminals and remove the wires.
7. Remove the two screws holding the valve to the bracket.

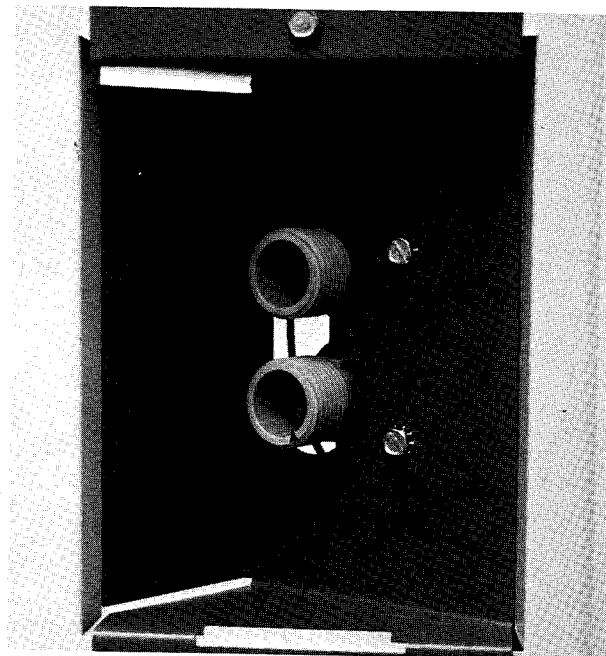

Installing new valve:

1. Mount the new valve to the bracket.
2. When replacing the wires, note the "H" and the "C" marked on the bracket for the hot and cold water hoses. Wire accordingly.
3. Replace hose and clamp on the outlet of the valve.
4. Attach to the washer cabinet.
5. Open water faucets and check for leaks.
6. Slid washer into place and connect power supply.
7. Place timer in fill position and check for correct water temperatures coming into tub (let water run for a short time before checking).

WATER PRESSURE GAUGE

A flow-pressure tester can be made up easily using locally available fittings and water pressure gauge.

Static pressure: Pressure when valve is closed.

Dynamic pressure: Pressure when valve is open and water is flowing. If this pressure is below 30 lbs. p.s.i., valve in washer may not close properly.

DIVERTER VALVE - SUDS SAVER MODELS

SUDS-SAVER

If the "Suds-Saver" button is depressed, the diverter valve solenoid will be energized in the first spin cycle and the wash water will be forced in a direction shown below. Since the diverter valve solenoid is energized, discharge water will be forced into the storage tank.

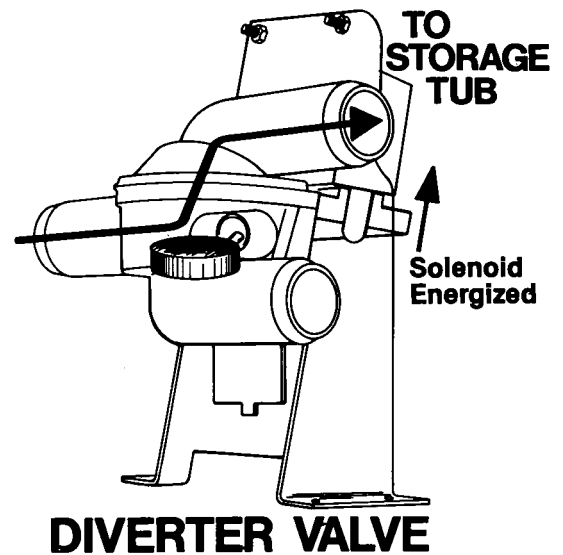

After two minutes has elapsed and during the rest of the first spin, the electrical circuit to the diverter solenoid is open. During the flush rinse portion of the spin and damp dry cycle, the diverter valve is in the position shown in the following drawing and all rinse water is directed to the drain.

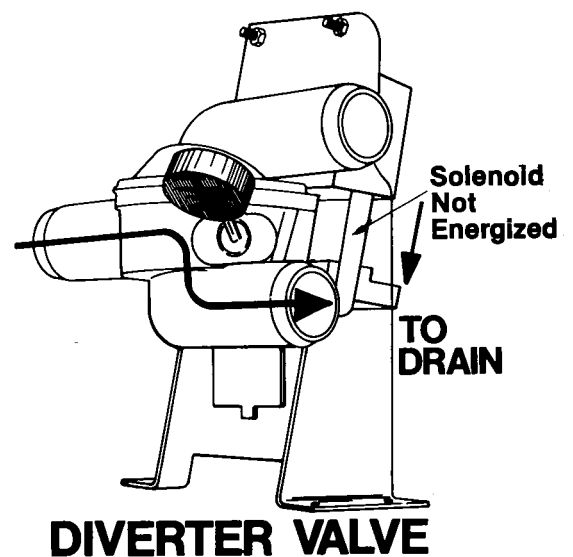

Note: It is important to tell the customer that it is not possible to save

suds when the Permanent Press cycle is used.

The Suds-Saver feature was not incorporated into the Permanent Press cycle primarily because of the cool-down period. The cool-down period consists of two partial drain periods and a refill with cold water after each partial drain. If water from the two partial drains were pumped into the storage tank plus the full tub of water after the wash cycle, the storage tank would overflow.

SUDS RETURN

Assuming the wash water has been saved, there must be a suitable method of returning it to the washer for reuse when needed.

To return the stored water:

1. Depress the "Suds-Saver" switch on the control panel.
2. Set the timer dial to "Suds Return" and pull the knob out.

The diverter valve solenoid is energized which opens the passage from the storage tub and closes the passage to the drain. When the motor starts,

the pump impeller is moving and the water entering the pump from the storage tub is forced into the washer. Since the washer is agitating as it fills, the operator should wait until filling is completed before putting clothes in.

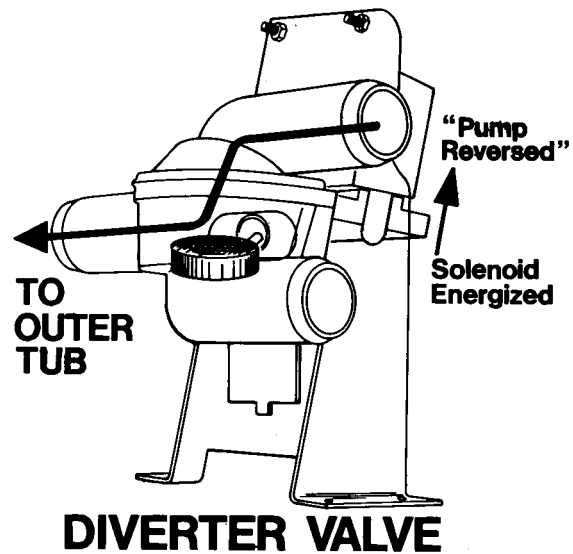

Note: After the suds are returned the timer will not automatically advance into the wash cycle or add make-up water. The timer must be manually advanced into the wash cycle. The timer motor is not energized during Suds Return and if not manually advanced into the wash cycle, the washer will agitate continuously until the timer is advanced.

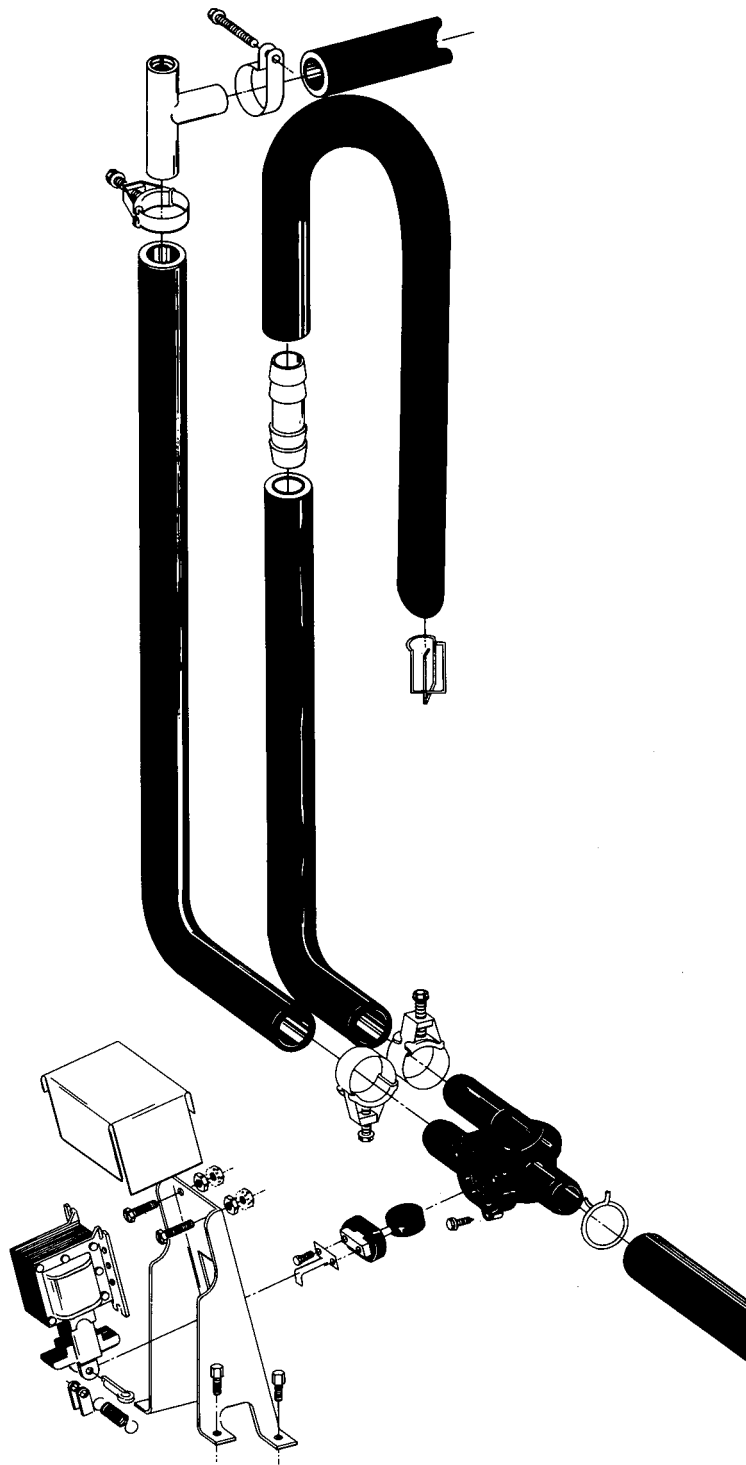

SUDS SAVER COMPONENTS

SECTION 4. GENERAL INFORMATION

PRE-INSTALLATION CONSIDERATIONS

ELECTRICAL SERVICE

15 amp fuse or comparable circuit breaker.

Do not operate washer on "drop cord" or overloaded circuits.

WATER PRESSURE

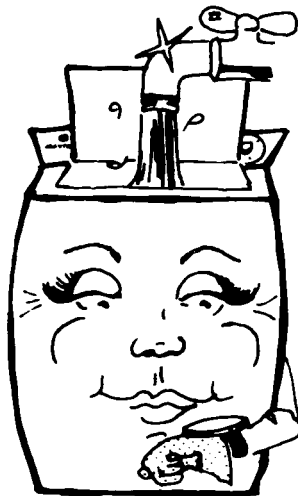

Water pressure of 30 - 120 p.s.i. is required to correctly fill the washer to

the proper levels. Pressures of less than 30 p.s.i. may cause an extended or exceptionally long fill time.

Water inlet hoses packed with the washer are 5' long. If longer or extension hoses are needed, these are available through Maycor.

WARNING

TO AVOID THE POSSIBILITY OF WATER DAMAGE, SHOULD A HOSE LEAK, ALWAYS HAVE FAUCETS ACCESSIBLE AND TURN OFF FAUCETS WHEN WASHER IS NOT IN USE.

WATER TEMPERATURE

COLD- Same as cold water faucets deliver.

HOT- Same as hot water faucets deliver.

WARM - Any warm setting may vary in temperature depending on existing temperatures of the hot and cold water. Warm water is also a mixture dependent on the pressure of both hot and cold water supplies. This means warm water temperature is NOT thermostatically controlled and can vary in temperature range.

DRAIN FACILITIES

STANDARD MODELS

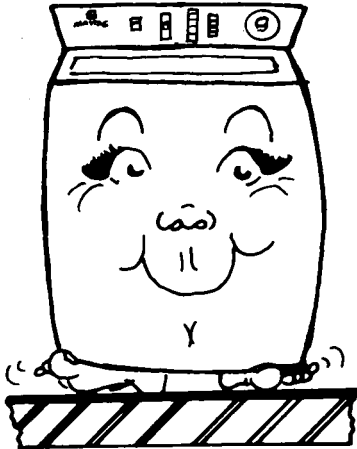

These models are equipped with a built-in siphon break which automatically elevates the drain hose to the proper height. The drain hose should be installed in a standpipe, which must be large enough to accept a 1 1/2" outside diameter drain hose.

SUDS SAVER MODELS

These models are not equipped with a siphon break and must be elevated to height of 36". Preferably a 36" high standpipe is recommended. On installations where the drain hose cannot be conveniently elevated to 36" an accessory, 2-01112 siphon break, is available. **WITHOUT THE 36" HIGH ELEVATION OR A SIPHON BREAK, WATER MAY RUN OUT OF THE WASHER PREMATURELY.** If the washer fills and drains at the same time this would indicate

that the drain hose has not been elevated to the proper height. Drain facilities must be capable of handling a 1 1/2" outside diameter drain hose.

ALL MODELS

Note: CAUTION MUST ALWAYS BE EXERCISED TO AVOID "KINKING" THE DRAIN HOSE. For best performance the drain hose should not be restricted in any way, through elbows, couplings or excessive lengths. All unnecessary drain hose should be cut off to avoid restrictions.

FLOORING



For best performance the washer must be installed on a solid floor. Wood floor constructions may sometimes need to be reinforced to minimize vibration from unbalanced load situations. Carpets and soft tile surfaces are also contributing factors in vibration and/or tendency for a washer

to move slightly during spin cycle. A special carpet installation kit is available as an accessory (2-04986) to provide a solid base for each leveling leg. It is composed of four small steel plates which can be "nailed" to a wooden, carpeted floor. These plates will reduce vibration between leveling leg of washer and floor surface.

Never install washer on a platform or weak support structure.

TEMPERATURE CONSIDERATIONS

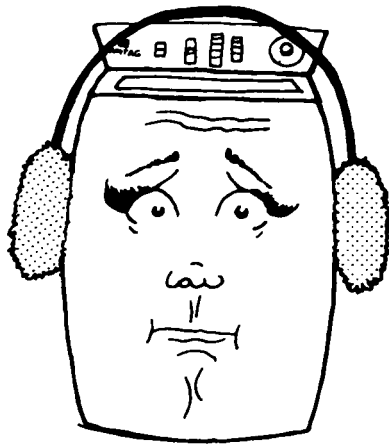

Since the washer always maintains some water in the water valve, pump and hose areas, it is recommended the washer never be installed in areas where water may freeze. This can cause damage to belts, pump, hoses and other components.

COLD WEATHER STORAGE

If a washer is to be stored where it would be subject to freezing conditions the following precautions should be taken:

1. Turn off water supply, remove and drain inlet hoses.
2. Set timer to a fill cycle and energize water valve by depressing a warm water setting. A few seconds is sufficient.
3. Remove water from drain hose and pump.

THINGS TO REMEMBER

A. LUBRICATION

No routine lubrication or adjustments are required to maintain this product. This does not mean the product will never need attention. In the event something does need attention please contact an authorized Maytag dealer.

B. FINISH

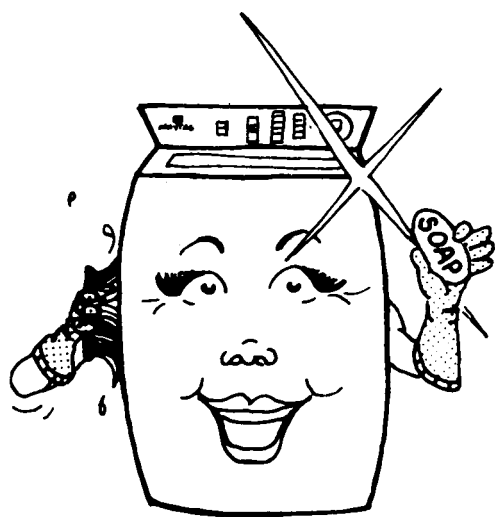

The cabinet and external finishes are protected against rust to keep the product looking well for many years. As with any other piece of equipment, cleaning and waxing maintains the beauty of these finishes.

CAUTION

If "spilled" or used improperly, bleaches and other strong laundering chemicals can permanently spot or stain finishes unless wiped off immediately.

The top cover, lid and inner tub of the washer have a porcelain enamel finish. Since porcelain is actually "glass" which is bonded to metal, it is very durable. However, care should be exercised to avoid damage by sharp blows from objects or tools used around and in the product. Porcelain can be chipped.

C. WATER DAMAGE FROM FLOODING

In the event the washer should be exposed to water from basement flooding, call your dealer for proper maintenance attention before using. Always unplug product and have a qualified technician inspect appliance before any attempt is made to operate the unit. Never wash product inside and out with a garden hose or pressure cleaning system.

ELECTRICAL REQUIREMENTS

OBSERVE ALL NATIONAL ELECTRICAL CODES AND LOCAL CODES & ORDINANCES

ELECTRICAL SERVICE - 120 volts, 60 HZ ONLY

A 120 volts, 60 Hz, 15 ampere fused electrical supply is required. An individual branch (or separate circuit serving only this appliance is recommended). DO NOT USE AN EXTENSION CORD unless it meets all requirements as outlined for grounding, polarizing (3-wire) and capacity. Wire size should be at least No. 14.

BEFORE PLUGGING IN POWER CORD, OPERATING OR TESTING, follow grounding instructions in Grounding Section.

GROUNDING - 120 volts, 60 HZ

IMPORTANT SAFETY PRECAUTIONS

WARNING

To prevent unnecessary risk of fire, electrical shock or personal injury, all wiring and grounding must be done to comply with the National Electrical Code and local codes and ordinances. It is the personal responsibility and obligation of the appliance owner to provide adequate electrical service for this appliance.

ELECTRICAL GROUND IS REQUIRED ON THIS APPLIANCE

This appliance has a power supply cord having a 3-prong grounding plug. For your safety, this cord must be plugged into a mating 3 prong type wall receptacle which is properly wired, grounded and polarized.

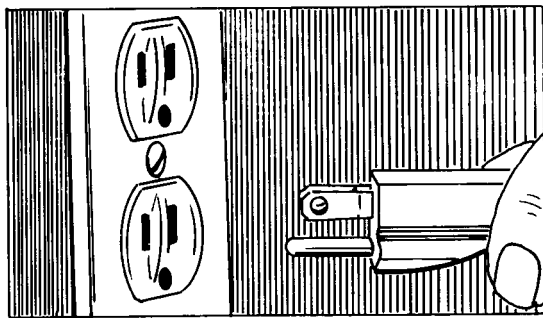

If a mating wall receptacle is not available, contact a qualified electrician to have the wall receptacle replaced. If there is any question, local building officials or electrical utility should be consulted.

WARNING

DO NOT UNDER ANY CIRCUMSTANCES, REMOVE THE ROUND GROUNDING PRONG FROM THE POWER SUPPLY CORD.

ADDITIONAL GROUND PROCEDURE - WHERE LOCAL CODE PERMITS

An external ground wire, clamp and screws are provided for assistance in meeting local codes. Where approved, it is recommended this additional ground be installed. A proper external ground **MUST** be determined before wire hook-up. Consult local building officials or qualified electrician in the event any questions exist.

GENERAL SPECIFICATIONS

| | | |
|------------------------------|---|----------------------------------|
| DIMENSIONS | Height to top of cabinet | 36" - 91.4cm |
| | Height to top of control panel | 43 5/8" - 110.8cm |
| | Height (lid open) | 51" - 129.5cm |
| | Width | 25 1/5" - 64.8cm |
| | Depth (including 1 1/2" overhang) | 27" - 68.6cm |
| WEIGHT | Crated | Approx. 225 lbs. - 102 kg |
| | Uncrated | Approx. 200 lbs. - 91 kg |
| WATER USAGE | Small | 24 gallons (20 Imp.)(91 liters) |
| | Medium | 28 gallons (23 Imp.)(106 liters) |
| | Large | 36 gallons (30 Imp.)(136 liters) |
| | Extra Large | 42 gallons (35 Imp.)(160 liters) |
| OPERATING SPEED | | |
| Regular Action | Agitation | 150 OPM |
| | Spin | 618 RPM |
| Gentle Action (2 Speed Only) | Agitation | 100 OPM |
| | Spin | 412 RPM |
| MOTOR | 1/3 HP, 120 Volts, 60 HZ, Reversible, Thermoprotected, Automatic Reset. Use standard 15 amp fuse. | |
| POWER USAGE | From 0.1 to 0.17 KHW per complete cycle depending on load and wash time selected. | |
| HOSE LENGTH | Inlet | 5 feet (1.52m) |
| | Drain | 4 feet (1.22m) |

MODEL CHART

WASHERS OF THE 1990 LINE

| MODEL | SPEED COMBO | TEMP COMBO | WATER LEVEL | TUB COLOR | BLEACH DISP. | EXTRA RINSE | FILTER TYPE | RINSE DISP. | SOAK CYCLE | SUDS SAVE |
|----------------|-------------|------------|-------------|-----------|--------------|-------------|-------------|-------------|------------|-----------|
| EXTRA CAPACITY | | | | | | | | | | |
| A9900 Touch | 3 | 8 | 5 | W | X | X | SC | X | AUTO | - |
| A9800 | 4 | 5 | 1 | W | X | X | SC | X | AUTO | - |
| A9700 | 2 | 4 | 1 | W | X | - | SC | X | AUTO | X |
| A9600 | 2 | 4 | 1 | W | - | - | SC | X | - | X |
| A9400 | FM | 4 | 1 | W | X | - | SC | X | - | - |
| A9300 | FM | 4 | 1 | W | - | - | SC | X | - | - |
| A9200 | 1 | 3 | 4 | W | - | - | SC | X | - | - |
| A8840 | 2 | 3 | 1 | W | X | - | MAN | X | - | - |
| A8820 | 2 | 3 | 1 | W | - | - | MAN | - | - | - |
| A8800 | 2 | 3 | 1 | W | X | - | MAN | X | AUTO | - |
| A8740 | 2 | 4 | 1 | W | X | - | MAN | - | AUTO | - |
| A8700 | 2 | 4 | 1 | W | X | - | MAN | X | - | - |
| A8650 | FM | 3 | 4 | W | X | - | MAN | X | - | - |
| A8640 | FM | 3 | 4 | W | - | - | MAN | X | - | - |
| A8600 | 1 | 3 | 4 | W | - | - | MAN | X | - | - |
| A8520 | FM | 3 | 1 | W | X | - | MAN | X | - | - |
| A8500 | 1 | 3 | 4 | W | X | - | MAN | X | AUTO | - |
| A6910 | 2 | 4 | 1 | W | X | - | MAN | X | - | - |
| A5910 | FM | 3 | 1 | W | X | - | MAN | X | - | - |
| A4910 | 1 | 3 | 4 | W | X | - | MAN | X | - | - |

| MODEL | SPEED COMBO | TEMP COMBO | WATER LEVEL | TUB COLOR | BLEACH DISP. | EXTRA RINSE | FILTER TYPE | RINSE DISP. | SOAK CYCLE | SUDS SAVE |
|----------------|-------------|------------|-------------|-----------|--------------|-------------|-------------|-------------|------------|-----------|
| LARGE CAPACITY | | | | | | | | | | |
| A8440 | 2 | 3 | 1 | W | X | - | MAN | X | - | - |
| A8420 | 2 | 3 | 1 | W | - | - | MAN | X | - | - |
| A8340 | 2 | 4 | 1 | W | X | - | MAN | X | AUTO | - |
| A8240 | FM | 3 | 3 | W | - | - | MAN | X | - | - |
| A8200 | 1 | 3 | 3 | B | - | - | MAN | X | - | - |
| A8140 | FM | 3 | 1 | W | X | - | MAN | X | - | - |
| A8100 | 1 | 3 | 3 | B | X | - | SC | X | AUTO | - |
| A7800 | 2 | 4 | 1 | W | X | - | SC | X | - | X |
| A7500 | FM | 4 | 1 | W | X | - | SC | X | - | - |
| A7400 | FM | 4 | 1 | W | - | - | SC | X | - | - |
| A7300 | 1 | 4 | 3 | W | - | - | MAN | X | - | - |
| A5000 | 1 | 3 | 2 | B | - | - | MAN | X | AUTO | - |
| A3910 | 2 | 4 | 1 | W | X | - | MAN | X | - | - |
| A1910 | 1 | 3 | 3 | B | X | - | MAN | X | - | - |

| Abbreviation | Description |
|--------------|--|
| FM | FABRIC MATIC |
| W | WHITE TUB |
| B | BLUE TUB |
| SC | SELF-CLEAN FILTER |
| MAN | MANUAL CLEAN FILTER IN AGITATOR BARREL |

SCHEMATICS

| MODEL NO. | SEE PAGE |
|--|----------|
| A9900 | 4-9 |
| A9800 | 4-10 |
| A9700 A9600 A8740 A8700 A8340 A7800 A6910 A3910 | 4-11 |
| A9700S | 4-12 |
| A9400 A9300 A7500 A7400 | 4-13 |
| A9400S A7500S | 4-14 |
| A9200 A8600 A8500 A8200 A8100 A5000 A4910 A1910 | 4-15 |
| A8840 A8820 A8800 A8440 A8420 | 4-16 |
| A8650 A8640 A8520 A8240 A8140 A5910 | 4-17 |
| A7300 | 4-18 |

| FUNCTION | CONTACTS | REGULAR AGITATE | GENTLE AGITATE | FAST SPIN | SLOW SPIN |
|--------------------------------|----------------------|-----------------|----------------|-----------|-----------|
| REVERSING RELAY ENERGIZED | RD TO BK BR TO WH | | | | |
| REVERSING RELAY NONENERGIZED | RD TO WH BR TO BK | | | | |
| FAST RELAY ENERGIZED | BK TO BU | | | | |
| SLOW RELAY ENERGIZED | OR TO BU | | | | |
| FUNCTION | CONTACTS | EMPTY | LOW (1) | MED (3) | HIGH (5) |
| WATER LEVELS SEE FOOTNOTE 1 | 11 TO 13 or 14 | | | | |
| | 21 TO 23 or 24 | | | | |
| | 31 TO 32 | | | | |

1. FOR INTERMEDIATE WATER LEVELS (2) AND (4), COMPUTER AUTOMATICALLY CONTROLS FILL LEVEL BASED ON LOW (1) AND MED (3).

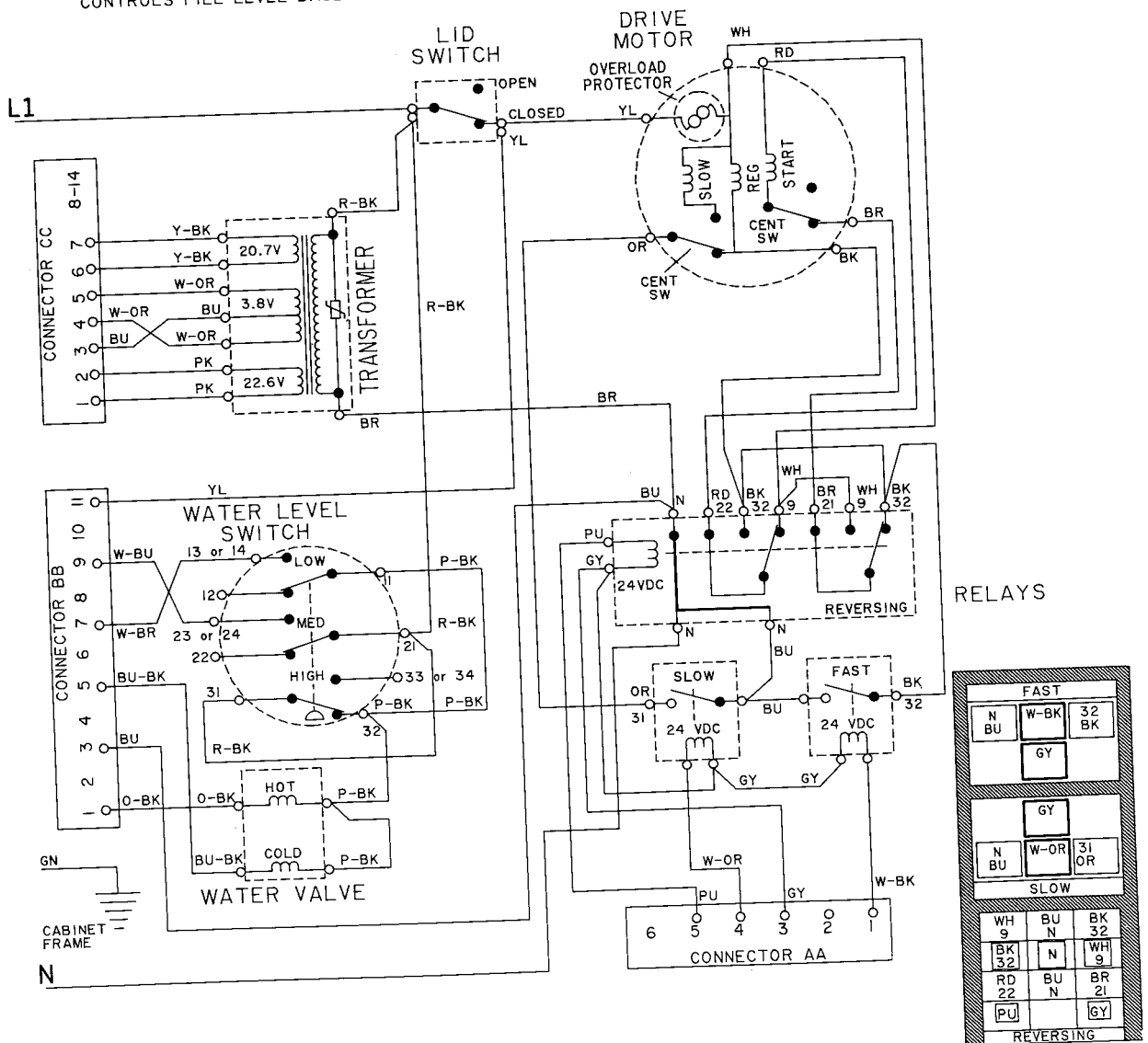

| TIMER INFORMATION | | | TIME CHART - 60 SECONDS PER INCREMENT | | | | | | | | | | | | |
|-------------------|---------------------|---------------------------------------|---------------------------------------|----|----|----|----|----|----|----|----|----|----|----|----|
| CAM NO. | CIRCUIT | FUNCTION | 5 | 10 | 15 | 20 | 25 | 30 | 35 | 40 | 45 | 50 | 55 | 60 | 65 |
| 1 | 7-N TO 16-J | SPIN AND TM BYPASS | | | | | | | | | | | | | |
| 2 | 3 TO 5B | FILL | | | | | | | | | | | | | |
| 3 | 7A TO 5B | FILL | | | | | | | | | | | | | |
| 4 | 5 TO 7T 5 TO 5B | FILL FILL | | | | | | | | | | | | | |
| 5 | 3A TO 16-J | AGITATE INTERRUPTER | | | | | | | | | | | | | |
| 6 | 3S TO 16-J | SPIN INTERRUPTER | | | | | | | | | | | | | |
| 7 | 2I TO 32 2I TO 9 | REVERSING- AGITATE REVERSING- SPIN | | | | | | | | | | | | | |
| 8 | 16-J TO 32 | ASSURED HIGH SPEED INT. | | | | | | | | | | | | | |
| 9 | 22 TO 9 22 TO 32 | REVERSING- AGITATE REVERSING- SPIN | | | | | | | | | | | | | |
| 10 | 1 TO 5 | EXTRA RINSE | | | | | | | | | | | | | |

| FUNCTION | PERMANENT PRESS | SOAK | REGULAR FABRICS |
|--------------|-----------------|------|-----------------|
| OFF | | | |
| FILL & WASH | | | |
| WASH - PAUSE | | | |
| COOL-DOWN | | | |
| RINSE-PAUSE | | | |
| SPIN | | | |
| FILL | | | |
| RINSE-PAUSE | | | |
| SPIN | | | |
| OFF | | | |
| FILL & WASH | | | |
| SOAK | | | |
| WASH | | | |
| SOAK | | | |
| FILL & WASH | | | |
| SPIN & SPRAY | | | |
| SPIN | | | |
| RINSE-PAUSE | | | |
| SPIN | | | |
| OFF OR FILL | | | |
| RINSE | | | |
| SPIN | | | |

CAM CLOSED EXCEPT FOR A SHORT PAUSE
 CAM MAY BE OPEN OR CLOSED
 CAM OPEN
 CAM CLOSED

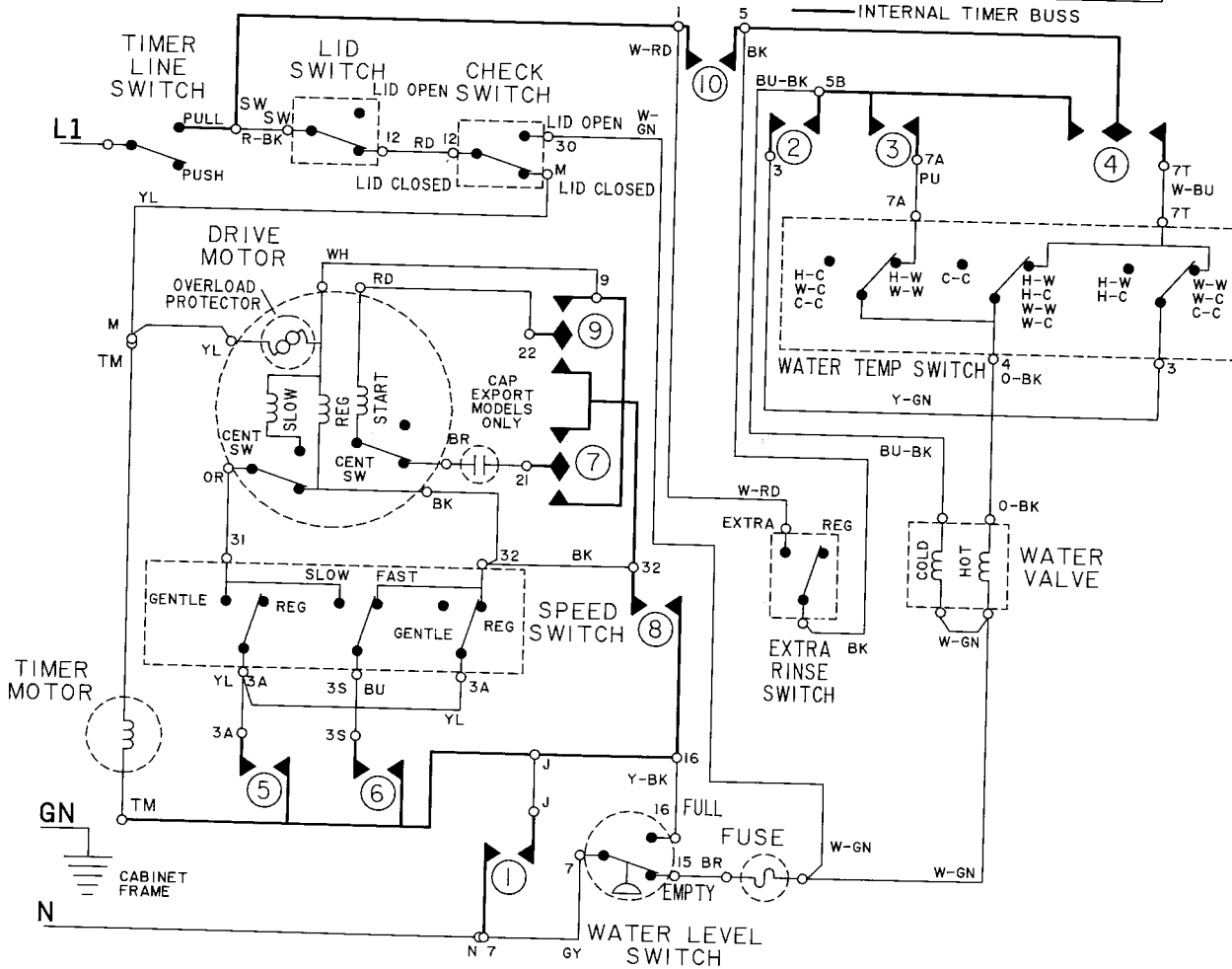

| TIMER INFORMATION | | | TIME CHART - 60 SECONDS PER INCREMENT | | | | | | | | | | | |
|-------------------|----------------------|---------------------------------------|---------------------------------------|----|----|----|----|----|----|----|----|----|----|----|
| CAM NO. | CIRCUIT | FUNCTION | 5 | 10 | 15 | 20 | 25 | 30 | 35 | 40 | 45 | 50 | 55 | 60 |
| 1 | 16-J TO 7-N | SPIN & TIMER MOTOR BYPASS | | | | | | | | | | | | |
| 2 | 5B TO 3 | FILL | | | | | | | | | | | | |
| 3 | 5B TO 7A | FILL | | | | | | | | | | | | |
| 4 | SW TO 7T SW TO 5B | FILL FILL | | | | | | | | | | | | |
| 5 | 16-J TO 3A | MOTOR INTERRUPTER | | | | | | | | | | | | |
| 6 | 21 TO 32 21 TO 9 | REVERSING- AGITATE REVERSING- SPIN | | | | | | | | | | | | |
| 7 | 16-J TO 32 | ASSURED HIGH SPEED | | | | | | | | | | | | |
| 8 | 22 TO 9 22 TO 32 | REVERSING- AGITATE REVERSING- SPIN | | | | | | | | | | | | |

| FUNCTION | 5 | 10 | 15 | 20 | 25 | 30 | 35 | 40 | 45 | 50 | 55 | 60 |
|----------------------------------|---|----|----|----|----|----|----|----|----|----|----|----|
| OFF | | | | | | | | | | | | |
| FILL & WASH | | | | | | | | | | | | |
| WASH-PAUSE COOL-DOWN PAUSE | | | | | | | | | | | | |
| SPIN | | | | | | | | | | | | |
| RINSE-PAUSE | | | | | | | | | | | | |
| SPIN | | | | | | | | | | | | |
| OFF | | | | | | | | | | | | |
| FILL & WASH | | | | | | | | | | | | |
| SOAK | | | | | | | | | | | | |
| WASH | | | | | | | | | | | | |
| SOAK | | | | | | | | | | | | |
| WASH | | | | | | | | | | | | |
| SOAK | | | | | | | | | | | | |
| FILL & WASH | | | | | | | | | | | | |
| WASH-PAUSE | | | | | | | | | | | | |
| SPIN | | | | | | | | | | | | |
| SPIN & SPRAY | | | | | | | | | | | | |
| SPIN & RINSE | | | | | | | | | | | | |
| RINSE & PAUSE | | | | | | | | | | | | |
| SPIN | | | | | | | | | | | | |

| CAM OPEN | CAM CLOSED EXCEPT FOR SHORT PAUSE | CAM CLOSED | CAM MAY BE OPEN OR CLOSED |
|----------|-----------------------------------|------------|---------------------------|
| □ | ▨ | ■ | ⊠ |

| FUNCTION | PERMANENT PRESS | SOAK | REGULAR FABRICS |
|----------|-----------------|------|-----------------|
| CYCLE | | | |

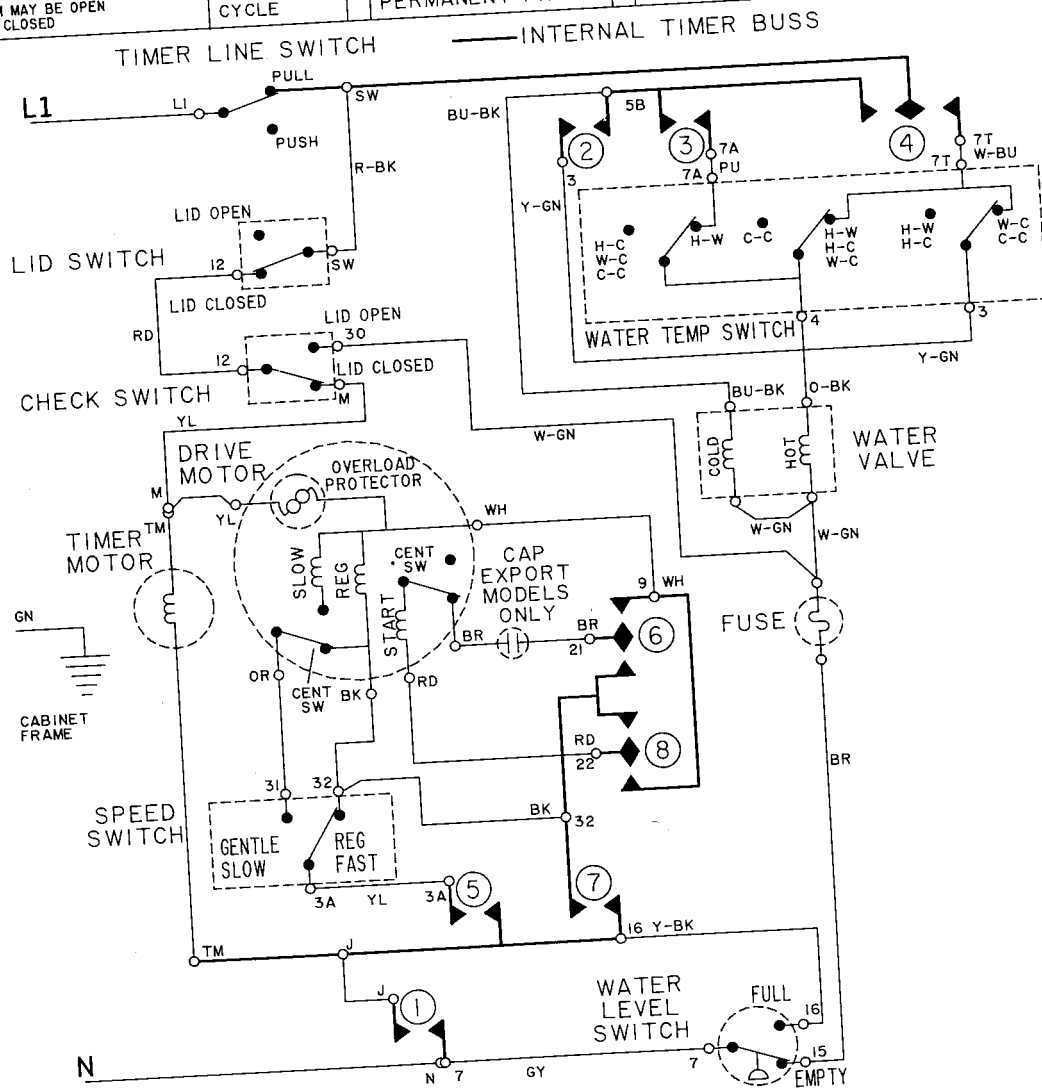

| TIMER INFORMATION | | | TIME CHART - 60 SECONDS PER INCREMENT | | | | | | | | | | | | | | | | | | |
|---|------------------------|---------------------------------------|---------------------------------------|-------------|------------|------------|------|------|-----------------|-----|-----|-------------|------|------|-----------------|-------------|------------|--------------|------|---------------|------|
| CAM NO. | CIRCUIT | FUNCTION | 5 | 10 | 15 | 20 | 25 | 30 | 35 | 40 | 45 | 50 | 55 | 60 | 65 | | | | | | |
| 1 | 16-J TO 7-N | SPIN & TIMER MOTOR BYPASS | | | | | | | | | | | | | | | | | | | |
| 2 | DV TO 15 DV TO 16-J | SUDS RETURN SUDS SAVE | | | | | | | | | | | | | | | | | | | |
| 3 | TM TO M-1 | TM ON-OFF | | | | | | | | | | | | | | | | | | | |
| 4 | 5B TO 3 | FILL | | | | | | | | | | | | | | | | | | | |
| 5 | 5B TO 7A | FILL | | | | | | | | | | | | | | | | | | | |
| 6 | SW TO 7T SW TO 5B | FILL FILL | | | | | | | | | | | | | | | | | | | |
| 7 | 16-J TO 3A | MOTOR INTERRUPTER | | | | | | | | | | | | | | | | | | | |
| 8 | 21 TO 32 21 TO 9 | REVERSING- AGITATE REVERSING- SPIN | | | | | | | | | | | | | | | | | | | |
| 9 | 16-J TO 32 | ASSURED HIGH SPEED | | | | | | | | | | | | | | | | | | | |
| 10 | 22 TO 9 22 TO 32 | REVERSING- AGITATE REVERSING- SPIN | | | | | | | | | | | | | | | | | | | |
| <input type="checkbox"/> CAM OPEN <input checked="" type="checkbox"/> CAM CLOSED EXCEPT FOR SHORT PAUSE <input checked="" type="checkbox"/> CAM CLOSED <input checked="" type="checkbox"/> CAM MAY BE OPEN OR CLOSED | | | FUNCTION | | | CYCLE | | | PERMANENT PRESS | | | SOAK | | | REGULAR FABRICS | | | | | | |
| | | | OFF | FILL & WASH | WASH-PAUSE | WASH-PAUSE | SPIN | SPIN | SPIN | OFF | OFF | FILL & WASH | SOAK | SOAK | SOAK | FILL & WASH | WASH-PAUSE | SPIN & SPRAY | SPIN | RINSE & PAUSE | SPIN |

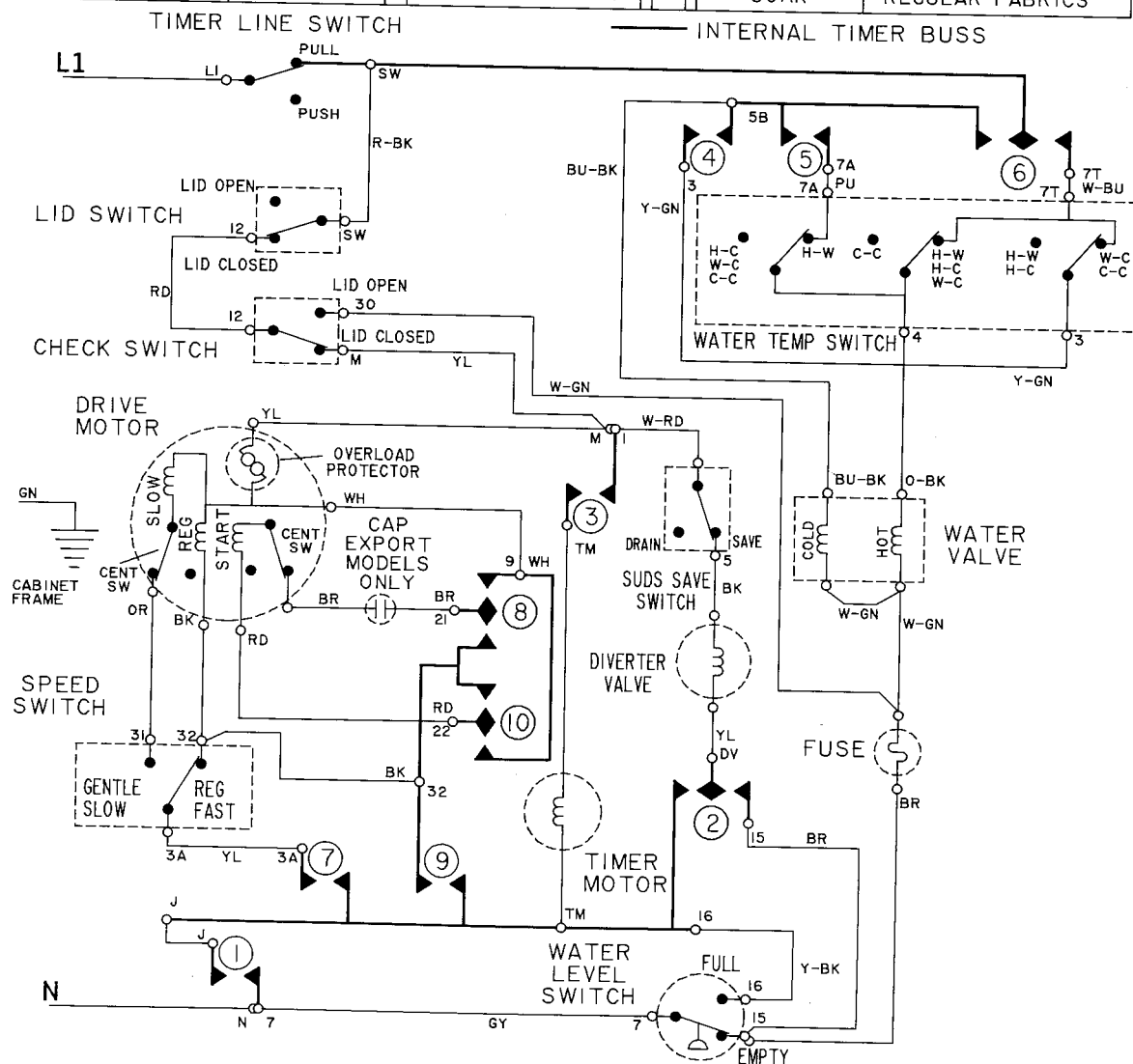

| TIMER INFORMATION | | | TIME CHART - 60 SECONDS PER INCREMENT | | | | | | | | | | | | | | | | | |
|--|-------------|---------------------------|--|----|----|----|----|----|-----------|----|----|----|----|----|-----------------|--|--|--|--|--|
| CAM NO. | CIRCUIT | FUNCTION | 5 | 10 | 15 | 20 | 25 | 30 | 35 | 40 | 45 | 50 | 55 | 60 | | | | | | |
| 1 | 16-J TO 7-N | SPIN & TIMER MOTOR BYPASS | | | | | | | | | | | | | | | | | | |
| 2 | 3 TO 5B | FILL | | | | | | | | | | | | | | | | | | |
| 3 | 7A TO 5B | FILL | | | | | | | | | | | | | | | | | | |
| 4 | SW TO 7T | FILL | | | | | | | | | | | | | | | | | | |
| | SW TO 5B | FILL | | | | | | | | | | | | | | | | | | |
| 5 | 32 TO 16-J | MOTOR INTERRUPTER | | | | | | | | | | | | | | | | | | |
| 6 | 21 TO 32 | REVERSING AGITATE | | | | | | | | | | | | | | | | | | |
| | 21 TO 9 | REVERSING SPIN | | | | | | | | | | | | | | | | | | |
| 7 | 22 TO 9 | REVERSING AGITATE | | | | | | | | | | | | | | | | | | |
| | 22 TO 32 | REVERSING SPIN | | | | | | | | | | | | | | | | | | |
| CAM OPEN CAM CLOSED EXCEPT FOR SHORT PAUSE CAM CLOSED CAM MAY BE OPEN OR CLOSED | | | FUNCTION OFF FILL & WASH WASH-PAUSE COOL-DOWN PAUSE SPIN RINSE-PAUSE SPIN OFF WASH SOAK WASH SOAK SPIN SPIN & SPRAY FILL RINSE-PAUSE SPIN OFF FILL & WASH WASH & PAUSE SPIN SPIN & SPRAY SPIN FILL RINSE-PAUSE SPIN | | | | | | | | | | | | | | | | | |
| CYCLE | | | PERMANENT PRESS | | | | | | DELICATES | | | | | | REGULAR FABRICS | | | | | |

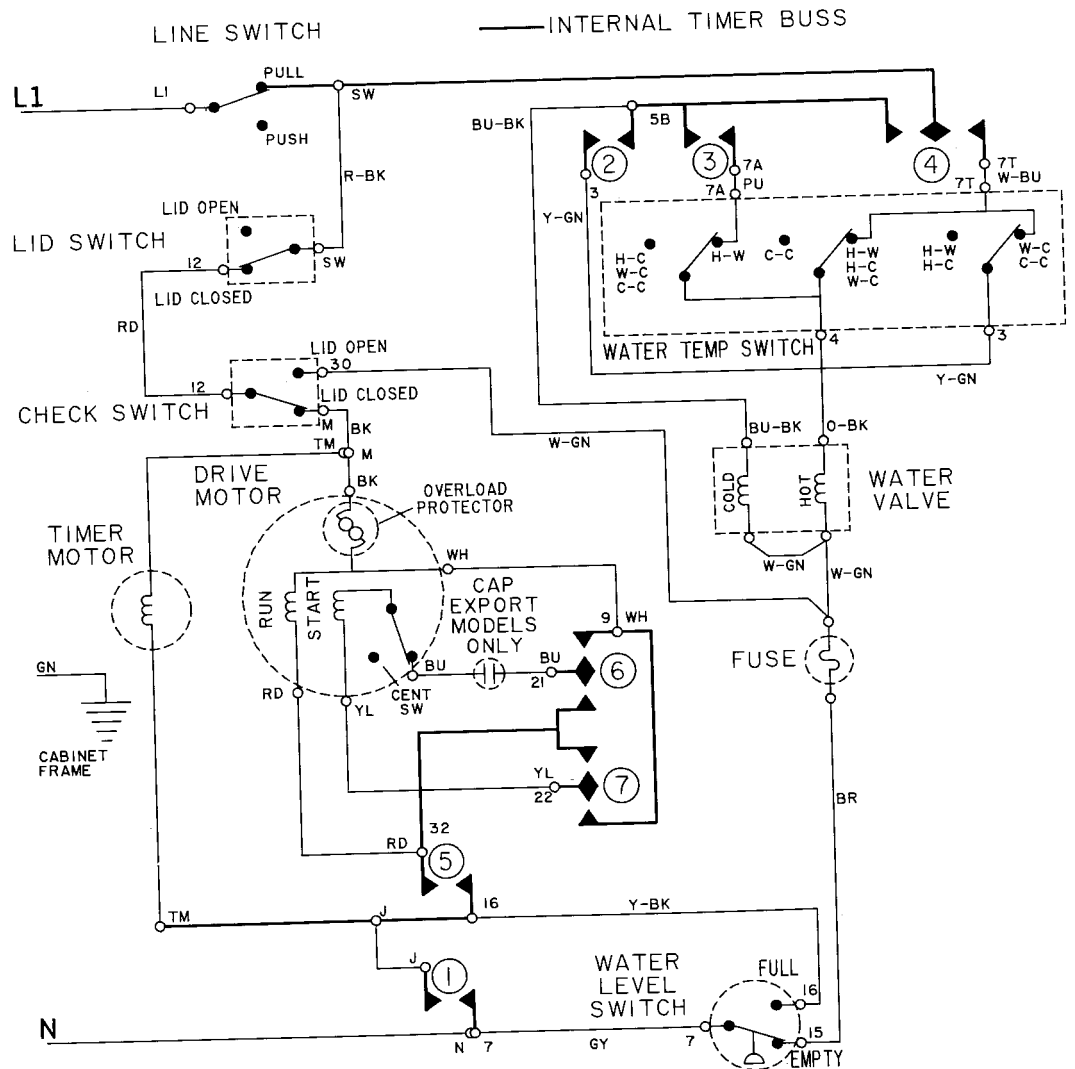

| TIMER INFORMATION | | | TIME CHART - 60 SECONDS PER INCREMENT | | | | | | | | | | | | | | | | | | | | | | | | | | | | |
|---|------------------------|---------------------------------------|---------------------------------------|-------------|------------|------------|------|-------------|------|------|-----|-------------|-----|-----------------|------|------|------|------|--------------|------|-------------|------|------|-----|-------------|------------|------|--------------|------|-------------|------|
| CAM NO. | CIRCUIT | FUNCTION | 5 | 10 | 15 | 20 | 25 | 30 | 35 | 40 | 45 | 50 | 55 | 60 | 65 | | | | | | | | | | | | | | | | |
| 1 | 16-J TO 7-N | SPIN & TIMER MOTOR BYPASS | | | | | | | | | | | | | | | | | | | | | | | | | | | | | |
| 2 | DV TO 15 DV TO 16-J | SUDS RETURN SUDS SAVE | | | | | | | | | | | | | | | | | | | | | | | | | | | | | |
| 3 | TM TO M-1 | TM ON-OFF | | | | | | | | | | | | | | | | | | | | | | | | | | | | | |
| 4 | 5B TO 3 | FILL | | | | | | | | | | | | | | | | | | | | | | | | | | | | | |
| 5 | 5B TO 7A | FILL | | | | | | | | | | | | | | | | | | | | | | | | | | | | | |
| 6 | SW TO 7T SW TO 5B | FILL FILL | | | | | | | | | | | | | | | | | | | | | | | | | | | | | |
| 7 | 16-TM TO 32 | MOTOR INTERRUPTER | | | | | | | | | | | | | | | | | | | | | | | | | | | | | |
| 8 | 21 TO 32 21 TO 9 | REVERSING- AGITATE REVERSING- SPIN | | | | | | | | | | | | | | | | | | | | | | | | | | | | | |
| 9 | 22 TO 9 22 TO 32 | REVERSING- AGITATE REVERSING- SPIN | | | | | | | | | | | | | | | | | | | | | | | | | | | | | |
| <input type="checkbox"/> CAM OPEN <input checked="" type="checkbox"/> CAM CLOSED <input checked="" type="checkbox"/> CAM CLOSED EXCEPT FOR SHORT PAUSE <input checked="" type="checkbox"/> CAM MAY BE OPEN OR CLOSED | | | FUNCTION | | CYCLE | | | | | | | | | | | | | | | | | | | | | | | | | | |
| | | | OFF | FILL & WASH | WASH-PAUSE | PAUSE-DOWN | SPIN | RINSE-PAUSE | FILL | SPIN | OFF | SUDS RETURN | OFF | FILL | WASH | SOAK | SOAK | SPIN | SPIN & SPRAY | SPIN | RINSE-PAUSE | FILL | SPIN | OFF | FILL & WASH | WASH-PAUSE | SPIN | SPIN & SPRAY | FILL | RINSE-PAUSE | SPIN |
| | | | PERMANENT PRESS | DELICATES | | | | | | | | | | REGULAR FABRICS | | | | | | | | | | | | | | | | | |

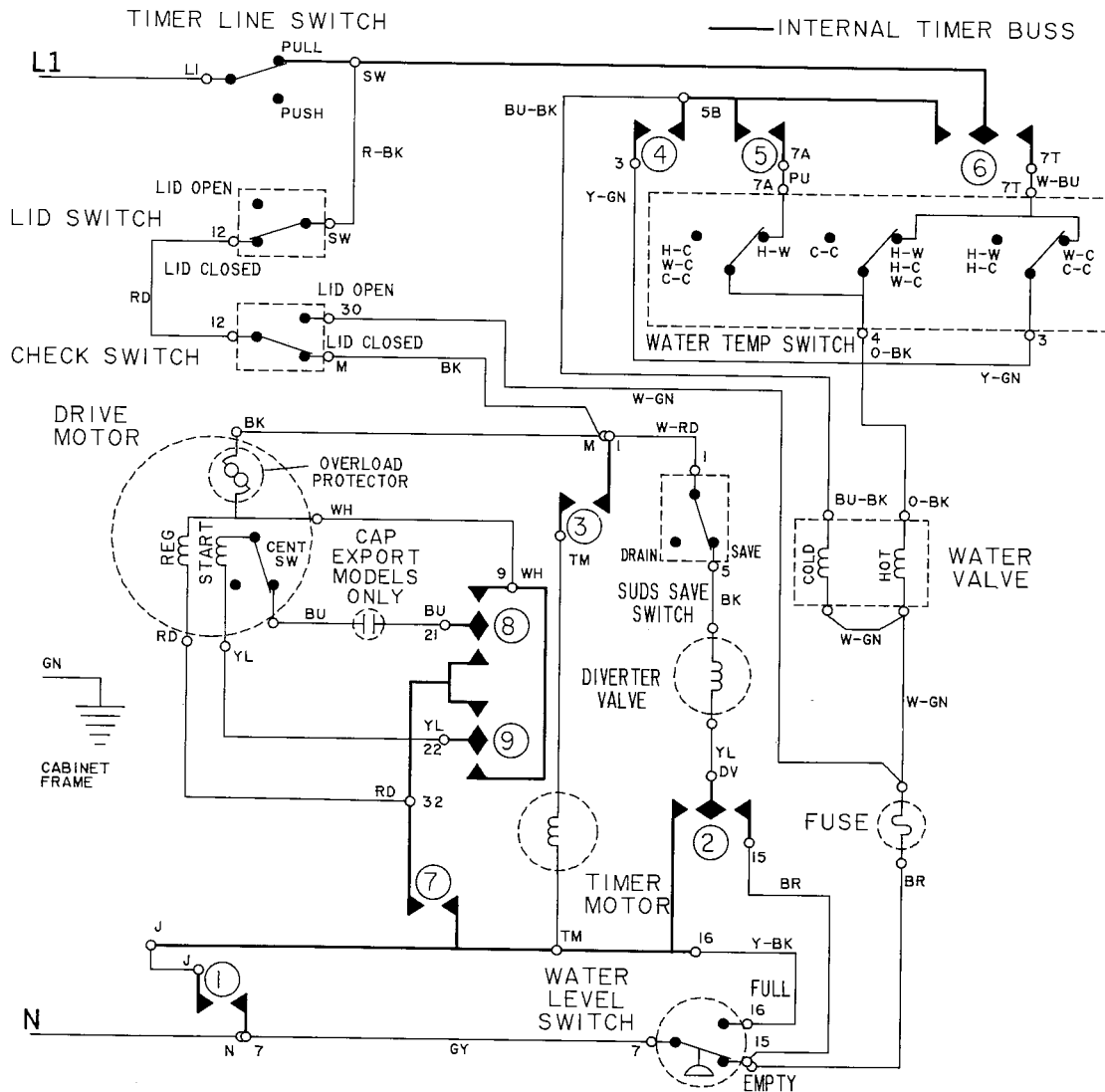

| TIMER INFORMATION | | | TIME CHART - 60 SECONDS PER INCREMENT | | | | | | | | |
|--|-------------|---------------------------|---------------------------------------|----|-----------------|----|----|----|----|----|----|
| CAM NO. | CIRCUIT | FUNCTION | 5 | 10 | 15 | 20 | 25 | 30 | 35 | 40 | 45 |
| 1 | 16-J TO 7-N | SPIN & TIMER MOTOR BYPASS | | | | | | | | | |
| 2 | 7T TO 7A | FILL | | | | | | | | | |
| 3 | SW TO 7T | FILL | | | | | | | | | |
| 4 | SW TO 3 | FILL | | | | | | | | | |
| 5 | 16-J TO 32 | MOTOR INTERRUPTER | | | | | | | | | |
| 6 | 21 TO 32 | REVERSING- AGITATE | | | | | | | | | |
| | 21 TO 9 | REVERSING- SPIN | | | | | | | | | |
| 7 | 22 TO 9 | REVERSING- AGITATE | | | | | | | | | |
| | 22 TO 32 | REVERSING- SPIN | | | | | | | | | |
| □ CAM OPEN ▨ CAM CLOSED EXCEPT FOR SHORT PAUSE ▩ CAM CLOSED ⊠ CAM MAY BE OPEN OR CLOSED | | | FUNCTION | | CYCLE | | | | | | |
| | | | PERMANENT PRESS | | REGULAR FABRICS | | | | | | |

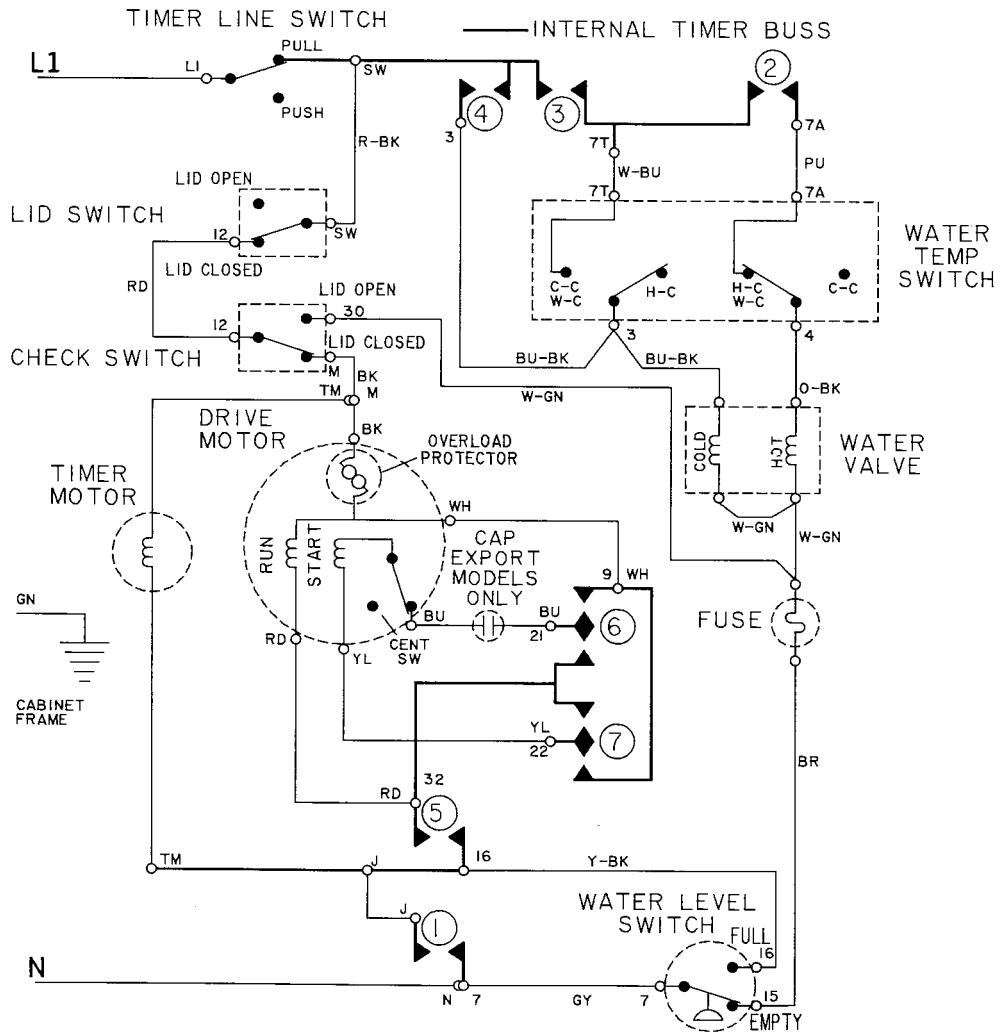

| TIMER INFORMATION | | | TIME CHART - 60 SECONDS PER INCREMENT | | | | | | | | | |
|-------------------|------------|-------------------------|---------------------------------------|----|----|----|----|----|----|----|----|----|
| CAM NO. | CIRCUIT | FUNCTION | 5 | 10 | 15 | 20 | 25 | 30 | 35 | 40 | 45 | 50 |
| ① | 7-N TO J | SPIN & TM BYPASS | | | | | | | | | | |
| ② | 7T TO 7A | FILL | | | | | | | | | | |
| ③ | 7T TO SW | FILL | | | | | | | | | | |
| ④ | 3 TO SW | FILL | | | | | | | | | | |
| ⑤ | 3A TO 16-J | MOTOR INTERRUPTER | | | | | | | | | | |
| ⑥ | 2I TO 32 | REVERSING-AGITATE | | | | | | | | | | |
| ⑦ | 16-J TO 32 | ASSURED HIGH SPEED INT. | | | | | | | | | | |
| ⑧ | 22 TO 9 | REVERSING-AGITATE | | | | | | | | | | |
| | 22 TO 32 | REVERSING-SPIN | | | | | | | | | | |

| | | | | | | | | | | | | | | | | |
|---|-----------------------------------|----------|-----------------|-----------------|-----------------|------|------|-------|------|-----|-------------|--------------|------|-------|------|--|
| □ | CAM OPEN | FUNCTION | OFF | FILL & WASH | COOL DOWN PAUSE | SPIN | FILL | RINSE | SPIN | OFF | FILL & WASH | SPIN & SPRAY | SPIN | RINSE | SPIN | |
| ▨ | CAM CLOSED | | | | | | | | | | | | | | | |
| ⊠ | CAM MAY BE OPEN OR CLOSED | CYCLE | PERMANENT PRESS | REGULAR FABRICS | | | | | | | | | | | | |
| ▩ | CAM CLOSED EXCEPT FOR SHORT PAUSE | | | | | | | | | | | | | | | |

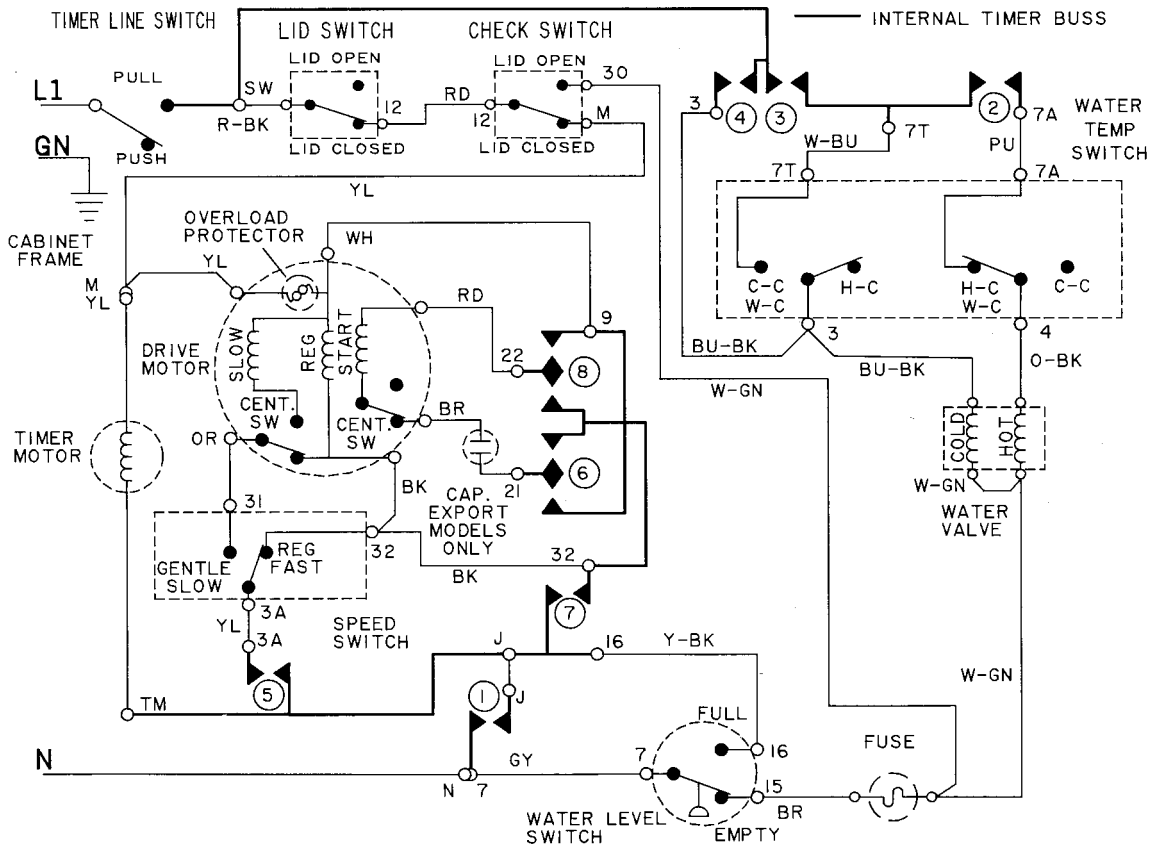

| TIMER INFORMATION | | | TIME CHART - 60 SECONDS PER INCREMENT | | | | | | | | | | | | | | | | | | | | | | | | | |
|--|-------------|---------------------------|---------------------------------------|-------------|--------------|------------|------|------|---------------|------|-----|------|------|-----------------|------|------|--------------|------|---------------|------|-----|-------------|--------------|------|--------------|------|---------------|------|
| CAM NO. | CIRCUIT | FUNCTION | 5 | 10 | 15 | 20 | 25 | 30 | 35 | 40 | 45 | 50 | 55 | 60 | | | | | | | | | | | | | | |
| 1 | 16-J TO 7-N | SPIN & TIMER MOTOR BYPASS | | | | | | | | | | | | | | | | | | | | | | | | | | |
| 2 | 7T TO 7A | FILL | | | | | | | | | | | | | | | | | | | | | | | | | | |
| 3 | 7T TO SW | FILL | | | | | | | | | | | | | | | | | | | | | | | | | | |
| 4 | 3 TO SW | FILL | | | | | | | | | | | | | | | | | | | | | | | | | | |
| 5 | 32 TO 16-J | MOTOR INTERRUPTER | | | | | | | | | | | | | | | | | | | | | | | | | | |
| 6 | 21 TO 32 | REVERSING AGITATE | | | | | | | | | | | | | | | | | | | | | | | | | | |
| | 21 TO 9 | REVERSING SPIN | | | | | | | | | | | | | | | | | | | | | | | | | | |
| 7 | 22 TO 9 | REVERSING AGITATE | | | | | | | | | | | | | | | | | | | | | | | | | | |
| | 22 TO 32 | REVERSING SPIN | | | | | | | | | | | | | | | | | | | | | | | | | | |
| □ CAM OPEN ▨ CAM CLOSED EXCEPT FOR SHORT PAUSE ■ CAM CLOSED ⊠ CAM MAY BE OPEN OR CLOSED | | | | | | | | | | | | | | | | | | | | | | | | | | | | |
| FUNCTION | | | OFF | FILL & WASH | WASH - PAUSE | PAUSE DOWN | SPIN | FILL | RINSE - PAUSE | SPIN | OFF | WASH | SOAK | WASH | SOAK | SPIN | SPIN & SPRAY | FILL | RINSE - PAUSE | SPIN | OFF | FILL & WASH | WASH & PAUSE | SPIN | SPIN & SPRAY | FILL | RINSE - PAUSE | SPIN |
| CYCLE | | | PERMANENT PRESS | DELICATES | | | | | | | | | | REGULAR FABRICS | | | | | | | | | | | | | | |

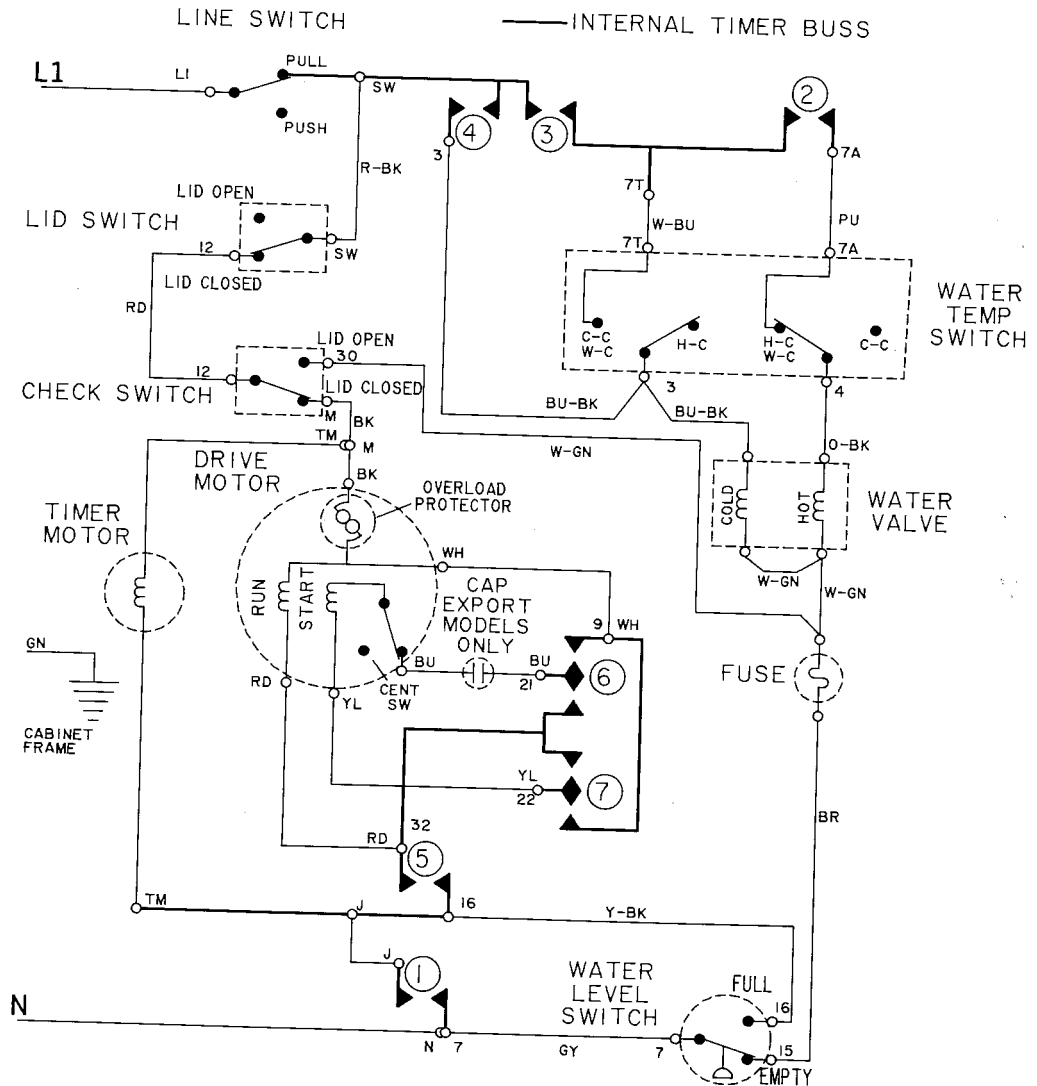

MAYTAG

Maytag Appliances Sales Company

Customer Service
240 Edwards Street, S.E.
Cleveland, Tennessee 37311