



Service

This manual is to be used by qualified appliance technicians only. Maytag does not assume any responsibility for property damage or personal injury for improper service procedures done by an unqualified person.

2004 Countertop Domestic Microwaves

This Base Manual covers general information

Refer to individual Technical Sheet
for information on specific models

This manual includes, but is
not limited to the following:

UMC1071AAB/W
AMC4080AAB/W/Q/S
MMC5080AAB/W/Q/S
AMC5101AAB/W/Q/S
AMC5143AAB/W/Q/S
MMC5193AAB/W/Q/S

MAYTAG®

16022923
Revision 0
April 2004

Important Information

Pride and workmanship go into every product to provide our customers with quality products. It is possible, however, that during its lifetime a product may require service. Products should be serviced only by a qualified service technician who is familiar with the safety procedures required in the repair and who is equipped with the proper tools, parts, testing instruments and the appropriate service manual. **REVIEW ALL SERVICE INFORMATION IN THE APPROPRIATE SERVICE MANUAL BEFORE BEGINNING REPAIRS.**

Important Notices for Consumers and Servicers



WARNING

To avoid risk of serious injury or death, repairs should not be attempted by an unauthorized service personnel, dangerous conditions (such as exposure to electrical shock) may result.



CAUTION

Maytag will not be responsible for any injury or property damage from improper service procedures. If performing service on your own product, assume responsibility for any personal injury or property damage which may result.

To locate an authorized servicer, please consult your telephone book or the dealer from whom you purchased this product. For further assistance, please contact:

Customer Service Support Center

CAIR Center

<u>Web Site</u>	<u>Telephone Number</u>
WWW.AMANA.COM	1-800-843-0304
WWW.MAYTAG.COM	1-800-688-9900
CAIR Center in Canada	1-800-688-2002
Amana Canada Product	1-866-587-2002

Recognize Safety Symbols, Words, and Labels



DANGER

DANGER—Immediate hazards which **WILL** result in severe personal injury or death.



WARNING

WARNING—Hazards or unsafe practices which **COULD** result in severe personal injury or death.



CAUTION

CAUTION—Hazards or unsafe practices which **COULD** result in minor personal injury or product or property damage.

Table of Contents

Important Information	2	Disassembly Procedures	
Important Safety Information	4	Door Assembly	19
Microwave Leakage Testing	5	Door Disassembly	19
General Information		Outer Case	20
Specifications	7	Control Panel	20
Placement of the Oven	7	P.C. Board	20
Location of Model Number	7	Control Key Panel	21
Model Identification	7	Interlock Door Latch Switches	21
Service	7	High Voltage Capacitor	22
Parts and Accessories	7	Diode	22
Asure™ Extended Service Plan	7	Transformer	22
Radio Interference	7	Fuse	23
Electrical Requirements	8	Magnetron	23
Cleaning	8	Suction Guide/Fan Motor Assembly	23
Grounding Instructions	8	Humidity Sensor-MMC5080AA*, AMC5143AA*, MMC5193AA*	24
Microwave Oven Description	9	Oven Thermostat	24
Troubleshooting Procedures		Light Socket	24
General	10	Turntable Motor	24
Error Codes		Appendix A	
Model MMC5080AA*	12	Installation Instructions for AMC5143AA*	A-2
Models AMC5143AA* and MMC5193AA*	12	Installation Instructions for AMC4080AA* and MMC5080AA*	A-6
Testing Procedures	13 - 16	Appendix B	
		Programming Instructions for AMC4080AA*	B-2
		Programming Instructions for MMC5080AA*	B-4
		Programming Instructions for AMC5101AA*	B-6
		Programming Instructions for AMC5143AA*	B-10
		Programming Instructions for MMC5193AA*	B-15
		Care and Cleaning	B-20

Important Safety Information



CAUTION

Read the following information to avoid possible exposure to microwave radiation:

The basic design of the Maytag and Amana microwave oven makes it an inherently safe device to both use and service. However, there are some precautions which should be followed when servicing the microwave oven to maintain this safety. These are as follows:

1. Always operate the unit from an adequately grounded outlet. Do not operate on a two-wire extension cord.
2. Before servicing the unit (if unit is operable), perform the microwave leakage test.
3. The oven should never be operated if the door does not fit properly against the seal, the hinges or hinge bearings are damaged or broken; the choke is damaged, (pieces missing, etc.); or any other visible damage can be noted. Check the choke area to ensure that this area is clean and free of all foreign matter.
4. If the oven operates with the door open and produces microwave energy, take the following steps.
 - A. Tell the user not to operate the oven.
 - B. Contact Maytag immediately.
5. Always have the oven disconnected when the outer case is removed except when making the "live" tests called for in the Service Manual. Do not reach into the equipment area while the unit is energized. Make all connections for the test and check them for tightness before plugging the cord into the outlet.
6. Always ground the capacitors on the magnetron filter box and H. V. Capacitor with an insulated-handle screwdriver before working in the high voltage area of the equipment compartment. Some types of failures will leave a charge in these capacitors and the discharge could cause a reflex action which could make you injure yourself.
7. In the area of the transformer, capacitor, diode, and magnetron there is HIGH VOLTAGE. When the unit is operating, keep this area clean and free of anything which could possibly cause an arc or ground, etc.
8. Do not for any reason defeat the interlock switches. There is no valid reason for this action at any time; nor will it be condoned by Maytag.
9. **IMPORTANT:** Before returning a microwave to a customer, check for proper switch interlock action. The primary and secondary switches **MUST** open when the door is actuated. The monitor switch **MUST** close at a 1/4 inch when the door is opened.
10. Before returning a microwave to a customer, verify the door spacing is reasonably uniform along the top, bottom, and sides, and that it measures 1/8 inch or less.
11. The microwave oven should never be operated with:
 - Any components removed and/or bypassed.
 - Any of the safety interlocks failing.
 - Any of the seal surfaces failing, missing, or damaged.
12. To ensure that the unit does not emit excessive microwave leakage and to meet the Department of Health Human Service guidelines, check the oven for microwave leakage using Narda Model 8100, 8200, Holaday HI1500, HI1501 or Simpson 380M leakage monitor as outlined in the instructions. The maximum leakage level allowed is 4mW/cm².
13. If servicer encounters an emission reading over 4 mW/cm² the servicer is to cease repair and contact the Maytag Service Department immediately for further direction. Maytag will contact the proper Government Agency upon verification of the test results.

Microwave Leakage Testing

WARNING

Check for radiation leakage after servicing. Should the leakage be more than 4mW/cm² inform Maytag immediately. After repairing or replacing any radiation safety device, keep a written record for future reference, as required by D.H.H.S. and HEW regulations. This requirement must be strictly observed. In addition, the leakage reading must be recorded on the service repair ticket while in the customer's home.

Equipment

- Electromagnetic radiation monitor
- 600 cc glass beaker

Procedure For Measuring Radiation Leakage

Note before measuring -

- Do not exceed meter full scale deflection. Leak monitor should initially be set to the highest scale.
 - To prevent false readings the test probe should be held by the grip portion of the handle only.
 - The scan speed is equal to one inch per antenna revolution or one inch per second if antenna speed is unknown.
 - Areas to be checked are all door seal areas and any venting parts.
 - Leakage with the outer panel removed...4mW/cm² or less.
 - Leakage for fully assembled oven with door normally closed ...4mW/cm² or less.
 - Leakage for a fully assembled oven (before the latch switch (primary) is interrupted) while pulling the door ... 4mW/cm² or less.
1. Pour 275 ±15 cc (9 oz ±1/2 oz) of 20 ± 5°C (68 ± 9°F) water in a beaker which is graduated to 600 cc and place the beaker in the center of oven.
 2. Set the radiation monitor to 2450 MHz and use it following the manufacturer's recommended test procedure to assure correct results.
 3. While measuring the leakage, always use the two inch (5 cm) spacer supplied with the probe.
 4. Press the start pad or turn on the timer and with the magnetron oscillating, measure the leakage by holding the probe perpendicular to the surface being measured.

Measurement With the Outer Panel Removed

DANGER

Avoid contacting any high voltage components.

Whenever you replace the magnetron, measure for radiation leakage before the outer panel is installed and after all necessary components are replaced or adjusted. Special care should be taken in measuring around the magnetron.

Measurement With a Fully Assembled Oven

After all components including the outer panel are fully assembled, measure for radiation leakage around the door periphery, the door viewing window, the exhaust opening, and air inlet openings.

Record Keeping and Notification After Measurement

1. After any adjustment or repair to a microwave oven, a leakage reading must be taken. Record this leakage reading on the repair ticket even if it is zero.
2. A copy of the repair ticket and the microwave leakage reading should be kept by the repair facility.

General Information

This manual provides basic instructions and suggestions for handling, installing, and servicing microwave ovens. The directions, information, and warnings in this manual are developed from experience with, and careful testing of the product. If the unit is installed according to the Installation Instructions, it will operate properly and will require minimal servicing. A unit in proper operating order ensures the consumer all the benefits provided by efficient microwave cooking.

This manual contains information needed by authorized service technicians to install and service the microwave oven pertaining to this manual. There may be, however, some information which needs further explanation. Refer to individual Installation Instructions, Use and Care, Technical Sheets, or toll free technical support line to answer questions from authorized service technicians.

Cooking Nomenclature

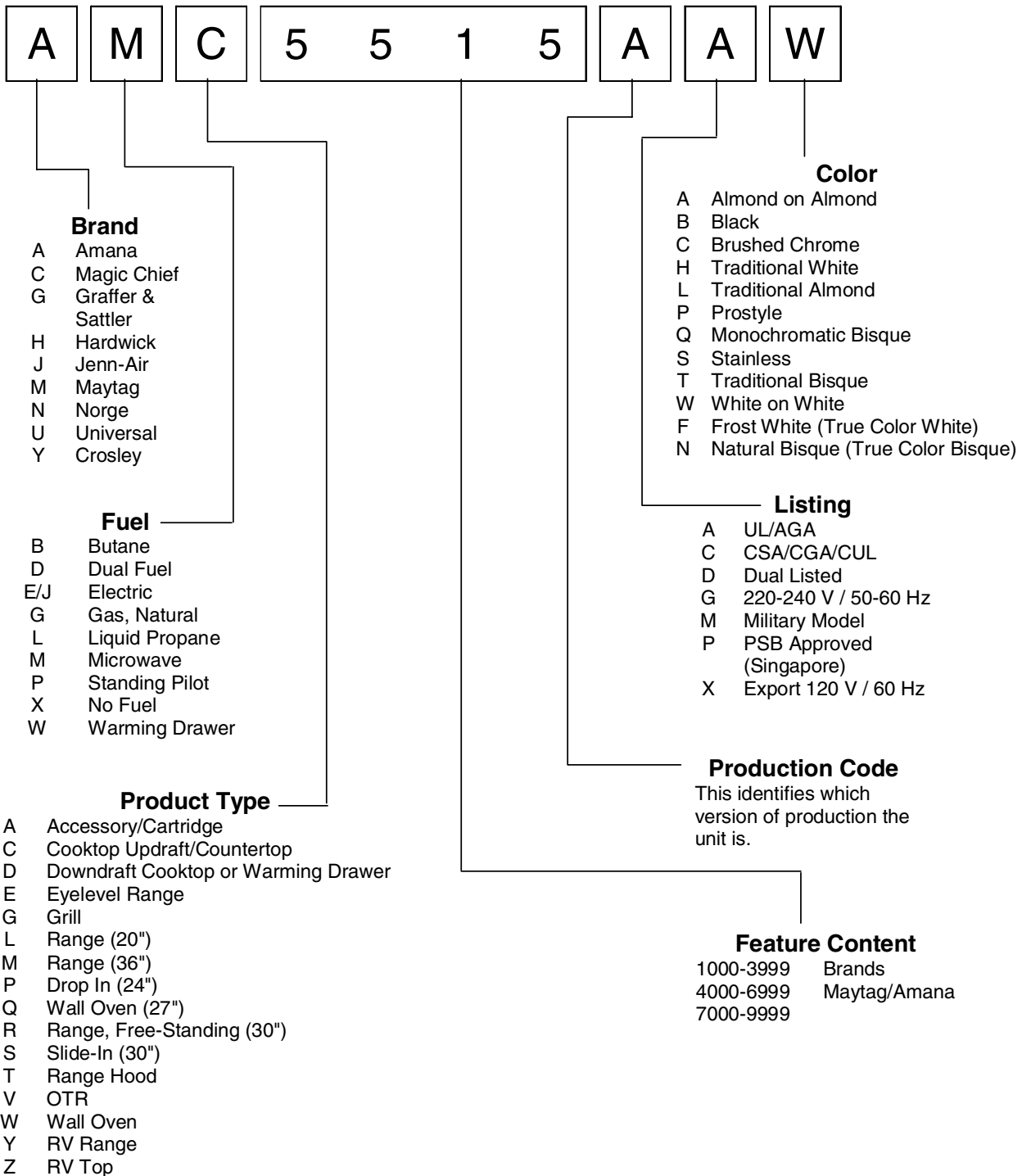

General Information

Specifications

Refer to individual Technical Sheet for specification information.

Placement of the Oven

This microwave can be easily placed in the kitchen, family room, or anywhere else in the house. Place the oven on a flat surface such as a kitchen countertop or a specially designed microwave oven cart. Do not place oven above a gas or electric range. Free air flow around the oven is important.

Do Not Block Air Vents

All air vents must be kept clear during cooking. If air vents are covered during operation the oven may overheat. In this case, a sensitive thermal safety device automatically turns the oven off. The oven will be inoperable until the oven has cooled sufficiently.

Location of Model Number

To request service information or replacement parts, the service center will require the complete model, serial, and manufacturing number of your microwave oven. The number is located on the oven front as shown in the illustration below.

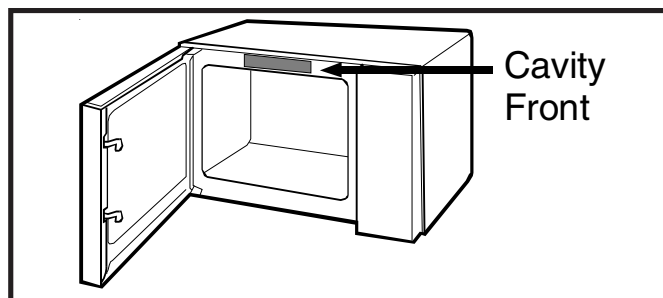

Model Identification

Complete enclosed registration card and promptly return. If registration card is missing:

- For Amana product call 1-800-843-0304 or visit the Web Site at www.amana.com
- For Maytag product call 1-800-688-9900 or visit the Web Site at www.maytag.com
- For product in Canada call 1-866-587-2002 or visit the Web Sites at www.amana.com or www.maytag.com

When contacting provide product information located on rating plate. Record the following:

Model Number: _____
Manufacturing Number: _____
Serial or S/N Number: _____
Date of purchase: _____
Dealer's name and address: _____

Service

Keep a copy of sales receipt for future reference or in case warranty service is required. To locate an authorized servicer:

- For Amana product call 1-800-628-5782 or visit the Web Site at www.amana.com
 - For Maytag product call 1-800-462-9824 or visit the Web Site at www.maytag.com
 - For product in Canada call 1-866-587-2002 or visit the Web Sites at www.amana.com or www.maytag.com
- Warranty service must be performed by an authorized servicer. We also recommend contacting an authorized servicer, if service is required after warranty expires.

Parts and Accessories

Purchase replacement parts and accessories over the phone. To order accessories for your product call:

- For Amana product call 1-877-232-6771 or visit the Web Site at www.amana.com
- For Maytag product call 1-800-462-9824 or visit the Web Site at www.maytag.com
- For product in Canada call 1-866-587-2002 or visit the Web Sites at www.amana.com or www.maytag.com

Extended Service Plan

We offer long-term service protection for this new oven.

- Asure™ Extended Service Plan is specially designed to supplement Amana's strong warranty. This plan covers parts, labor, and travel charges. Call 1-866-232-6244 for information.
- Dependability PlusSM Extended Service Plan is specially designed to supplement Maytag's warranty. This plan covers parts, labor, and travel charges. Call 1-800-925-2020 for information.

Radio Interference

1. Microwave oven operation may interfere with the radio or TV reception.
2. When there is interference, it may be reduced or eliminated by taking the following measures:
 - Clean the door and the seal surface of the oven.
 - Reorient the receiving antenna of the radio or TV.
 - Relocate the microwave oven in relation to the radio or TV.
 - Move the microwave away from the receiver.
 - Plug the microwave into a different outlet so that the microwave and receiver are on different branch circuits.
3. 120 VAC, 60 Hz household outlet. Be sure the circuit is at least 15 or 20 A and the microwave oven is the only appliance on the circuit. It is not designed for 50 Hz or any circuit other than a 120 VAC, 60 Hz circuit.
 - Electrical Rating of the Oven: 120 VAC, 60 Hz

General Information

Electrical Requirements

The oven is designed to operate on a Standard 120 VAC, 60 HZ household outlet.

Cleaning

Before cleaning the oven, unplug the power supply cord. If impossible, open the oven door to prevent an accidental oven start.

Inside of the Oven

Use a damp cloth to wipe out crumbs and spillovers. It is important to keep the area between door and cavity front clean to assure a tight seal. Remove greasy spatters with a sudsy cloth, then rinse and dry. Do not use harsh detergent or abrasive cleaners.

Glass Tray

The glass tray can be washed by hand or in the dishwasher.

Control Panel

Wipe with a damp cloth followed immediately by a dry cloth. The Child Lock feature is also useful when cleaning the control panel. Child Lock prevents accidental programming when wiping the control panel (if so equipped).

Door

If steam accumulates inside or around the outside of the oven door, wipe the panel with a soft cloth. This may occur when the microwave oven is operated under high humidity conditions and in no way indicates a malfunction of the unit.

Outside Oven Surface

Clean with damp cloth. To prevent damage to the operating parts inside the oven, the water should not be allowed to seep into the ventilation openings. After cleaning the oven, be sure that the rotating ring and the glass tray are in the right position. Press the STOP/CLEAR pad twice to reset any accidental key setting.

Grounding Instructions

This appliance must be grounded. If an electrical short circuit occurs, grounding reduces the risk of electric shock by providing an escape wire for the electric current. The cord for this appliance has a grounding wire with a grounding plug. Put the plug into an outlet that is properly installed and grounded.

 **WARNING**

To avoid risk of electric shock, personal injury or death, use grounding plug properly.

Ask a qualified electrician if you do not understand the grounding instructions or if you wonder whether the appliance is properly grounded.

Keep the electrical power cord dry and do not pinch or crush it in any way.

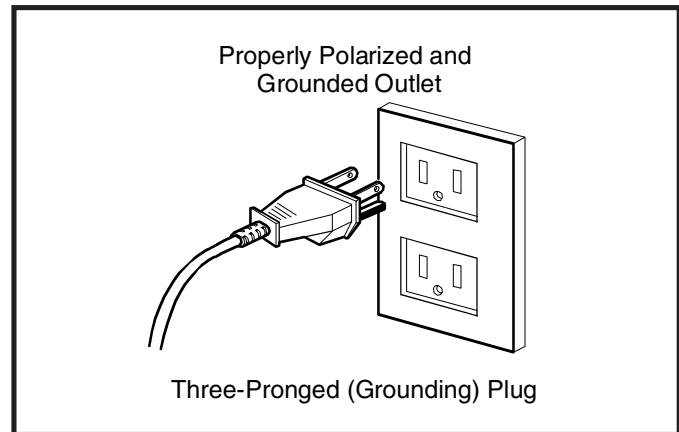

For a permanently connected appliance: This appliance must be connected to a grounded, metallic, permanent wiring system, or an equipment grounding conductor should be run with the circuit conductors and connected to the equipment grounding terminal or lead on the appliance.

General Information

Microwave Oven Description

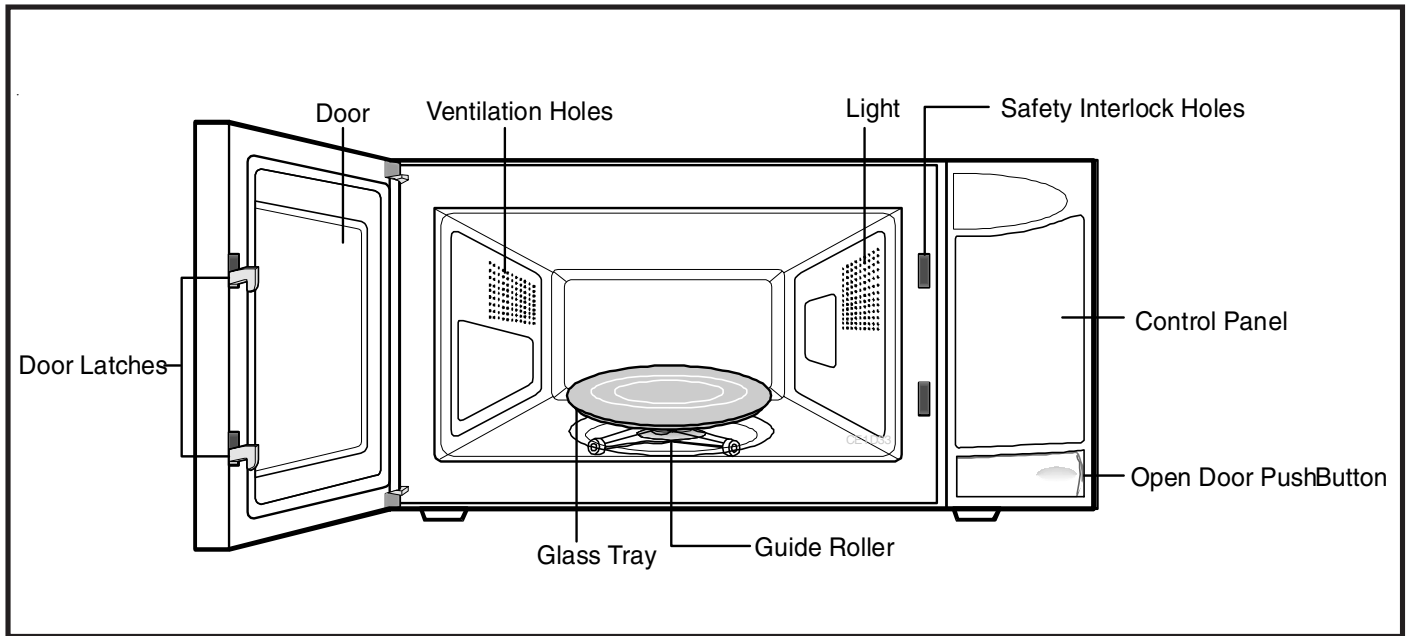

Troubleshooting Procedures

WARNING

To avoid risk of electrical shock, personal injury or death; disconnect power to oven and discharge the high voltage capacitor before servicing, unless testing requires power.

CAUTION

- Verify proper grounding before checking for trouble.
- Be careful of the high voltage circuit.
- Discharge the high voltage capacitor.
- When checking the continuity of the switches or of the high voltage transformer, disconnect one lead wire from these parts and then check continuity with the AC plug removed. To do otherwise may result in a false reading or damage to your meter.
- Do not touch any part of the circuit on the printed circuit board, since static electric discharge may damage the control panel. Always touch yourself to ground while working on this panel to discharge any static charge built up in your body.

Problem	Possible Cause	Correction
No display and no operation (fuse tests OK)	Open or loose lead wire harness..... Open thermal cutout (magnetron) Open low voltage transformer Defective Assembly PCB	<ul style="list-style-type: none"> • Check wire harness, thermal cutout and low voltage transformer for loose wires and continuity, tighten wires where necessary or replace failed component, if necessary. If thermal cutout is replaced, check fan motor. Replace if necessary. • Check Assembly PCB. Also, if low voltage transformer is defective, check/replace PCB.
No display and no operation (fuse blown)	Shorted lead wire harness..... Defective primary switch Defective monitor switch Shorted high voltage capacitor..... Shorted high voltage transformer	<ul style="list-style-type: none"> • Check adjustment of primary switch, monitor switch, power relay, door sensing switch. Readjust/replace if necessary. The primary, secondary and monitor switch must be replaced at the same time. • Check measurement of high voltage capacitor and high voltage transformer. Replace if necessary. If high voltage transformer is replaced, check magnetron and diode.
Cannot program oven	Key input is not in-sequence	<ul style="list-style-type: none"> • See Operation Procedure and verify program sequence • Check connections of membrane keypad to Assembly PCB, tighten/reconnect where necessary. • Replace Assembly PCB
	Open or loose membrane key pad to Assembly PCB connection	
	Membrane panel shorted or open Defective Assembly PCB	

Troubleshooting Procedures

Problem	Possible Cause	Correction
Timer begins countdown but microwave does not oscillate (oven lamp illuminates, fan motor engages but oven does not produce heat)	Latch switches not aligned properly Open or loose high voltage circuit connection, including magnetron filament circuit (greater contact resistance lowers magnetron filament voltage, resulting in lower magnetron output and/or intermittent oscillation) Defective high voltage components (transformer, capacitor, diode, fuse, magnetron) Open or loose power relay wiring Defective primary latch switch Defective power relay or Assembly PCB	<ul style="list-style-type: none"> • Adjust door and latch switches, replace if necessary • Check high voltage circuit connections. Tighten/reconnect where necessary • Check measurements on high voltage components. See test procedure in Replace component/s if necessary • Replace Assembly PCB
Oven lamp illuminates and fan motor engages	Maladjustment or loose wiring of primary latch switch Defective primary latch switch	<ul style="list-style-type: none"> • Check wiring connections and adjust door and latch switches. Replace if necessary.
Timer does not start once oven is programmed	Open or loose wiring of secondary interlock switch Off-alignment of primary interlock Defective secondary interlock switch	<ul style="list-style-type: none"> • Check wiring connections and adjust door and interlock switches. Replace if necessary.
Microwave output is low; oven takes longer time to cook food	Decrease in power source voltage..... Open or loose magnetron filament circuit (intermittent oscillation) Aged magnetron	<ul style="list-style-type: none"> • Consult electrician.
Fan motor engages when oven is connected to electrical source	Loose wiring on door sensing switch	<ul style="list-style-type: none"> • Check door sensing switch wire.
Oven does not operate and return to standby	Defective Assembly PCB	<ul style="list-style-type: none"> • Replace Assembly PCB
Oven emits loud noises when operating	Loose fan/fan motor Loose screws on high voltage transformer . Shorted high voltage diode	<ul style="list-style-type: none"> • Tighten screws of fan/fan motor. • Tighten screws of high voltage transformer. • Replace high voltage diode.
Turntable motor does not engage	Open or loose turntable motor wiring Defective turntable motor	<ul style="list-style-type: none"> • Check and replace turntable motor, if necessary.
Oven ceases operation during cooking process	Open or loose wiring of primary interlock switch	<ul style="list-style-type: none"> • Adjust door and latch switches.
Sparks emitting during cooking process	Metallic ware or cooking dishes touching the oven wall Ceramic ware trimmed with gold or silver powder	<ul style="list-style-type: none"> • Remove all cookware trimmed with metallic substances
Uneven cooking	Microware intensity characteristics	<ul style="list-style-type: none"> • Wrap thinner parts of food with aluminum foil, plastic wrap or cover with a lid. • Stir once or twice while cooking foods such as soup, cocoa or milk.
Noise emitting from turntable motor during operation	Motor	<ul style="list-style-type: none"> • Replace turntable motor.

Troubleshooting Procedures

Sensor Error Codes (Model MMC5080AA*)

Error Code	Possible Cause	Correction
Error 1	Shorted circuit.	<ul style="list-style-type: none">• Allow oven to cool for 5 minutes.• Check connection of wire at sensor.
Error 2	Open circuit.	<ul style="list-style-type: none">• Check connection of wire at sensor.
Error 3	During cooling, sensor output was not less than 4.7V within 3 minutes.	<ul style="list-style-type: none">• Allow oven to cool for 5 minutes.
Error 4	Door open when attempting to operate sensor program.	<ul style="list-style-type: none">• Close door, press PAUSE/CANCEL and restart.

Sensor Error Codes (Models AMC5143AA* and MMC5193AA*)





Error Code	Possible Cause	Correction
E1	Exceeds 1 time limit setting.	<ul style="list-style-type: none">• Press the PAUSE/CANCEL key and inspect the condition of the food.
E4	Sensor open.	<ul style="list-style-type: none">• Check connection of wire at sensor.
E5	Sensor shorted.	<ul style="list-style-type: none">• Allow oven to cool for 10 minutes.

Testing Procedures

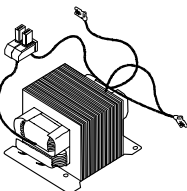
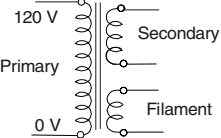
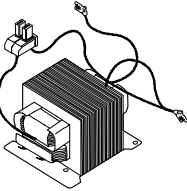
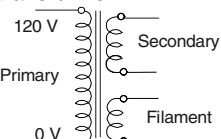
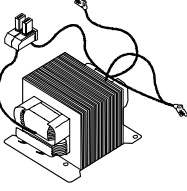
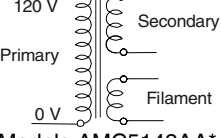

WARNING

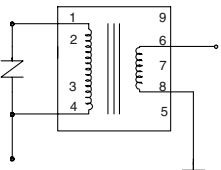
To avoid risk of electrical shock, personal injury or death; disconnect power to oven and discharge the high voltage capacitor before servicing, unless testing requires power.

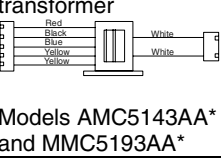
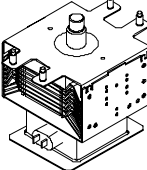
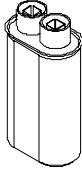
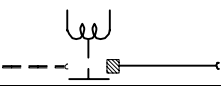
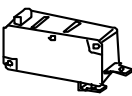
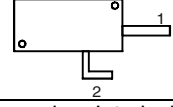
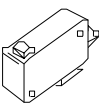
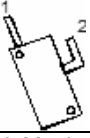

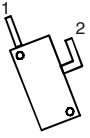

Illustration	Component	Test Procedure	Results
	<p>High voltage transformer</p>  <p>Models AMC4080AA* and MMC5080AA*</p>	<p>Discharge Capacitor Disconnect connector and measure continuity:</p> <p>Secondary..... Filament..... Primary.....</p> <p>(Measure at room temperature, or 70°)</p>	<p>Approximately 153 Ω Measures continuity Less than 1 Ω</p>
	<p>High voltage transformer</p>  <p>Models AMC5101AA*</p>	<p>Discharge Capacitor Disconnect connector and measure continuity:</p> <p>Secondary..... Filament..... Primary.....</p> <p>(Measure at room temperature, or 70°)</p>	<p>Approximately 129 Ω Measures continuity Less than 1 Ω</p>
	<p>High voltage transformer</p>  <p>Models AMC5143AA* and MMC5193AA*</p>	<p>Discharge Capacitor Disconnect connector and measure continuity:</p> <p>Secondary..... Filament..... Primary.....</p> <p>(Measure at room temperature, or 70°)</p>	<p>Approximately 87 Ω Measures continuity Less than 1 Ω</p>
	<p>Low voltage transformer</p>  <p>Models AMC4080AA*, MMC5080AA* and AMC5101AA*</p>	<p>Discharge Capacitor Remove from printed circuit board assembly and check continuity:</p> <p>Terminals 1-4 (Input)..... Terminals 6-8 (Output 12.6 VAC).....</p>	<p>Approximately 320 Ω Approximately 7.6 Ω</p>
	<p>Low voltage transformer</p>  <p>Models AMC5143AA* and MMC5193AA*</p>	<p>Discharge Capacitor Remove from printed circuit board assembly and check continuity:</p> <p>White Terminals (Input)..... Red-Black Terminal (Output 18 VAC)..... Black-Blue Terminal (Output 7.0 VAC) Yellow-Yellow Terminal (Output 2.28VAC)</p>	<p>Approximately 117 Ω Approximately 6 Ω Approximately 3 Ω Approximately 3 Ω</p>
	Magnetron	<p>Discharge Capacitor</p> <p>Remove wires from magnetron and connect ohmmeter to terminals. Also check between each terminal and ground.</p>	<p>Between Terminals: Less than 1 Ω Each terminal to ground: Infinite resistance. Note: This test is not conclusive. If oven does not heat and all other components test good replace the magnetron and retest.</p>
	High Voltage Capacitor	<p>Discharge Capacitor Remove wires from capacitor terminals and connect ohmmeter, set on highest resistance scale to terminals.</p> <p>Also check between each terminal and capacitor case.</p>	<p>Between Terminals: Meter should momentarily deflect towards zero then return to over 5M Ω. If no deflection occurs, or if continuous deflection occurs, replace capacitor. Terminal to Case: Infinite resistance</p>

Testing Procedures



WARNING

To avoid risk of electrical shock, personal injury or death; disconnect power to oven and discharge the high voltage capacitor before servicing, unless testing requires power.

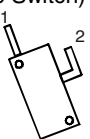
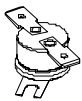



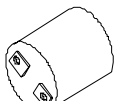
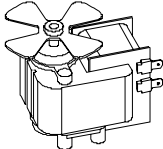
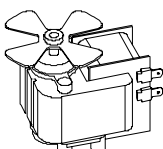



Illustration	Component	Test Procedure	Results
	High Voltage Diode	Discharge Capacitor Remove diode lead from capacitor and connect ohmmeter. Reverse leads for second test.	Infinite resistance should be measured in one direction and 50K Ω or more in the opposite direction. NOTE: Ohmmeter must contain a battery of 6 volts minimum.
	Main Relay/Power Control Relay	Disconnect the leads. Place water in the oven and set the power level to HIGH. Press START, then check continuity between the terminals of the relays.	Measures Continuity
 	Primary Interlock Switch Test (Top Switch)	Measure resistance between terminals 1 and 2: Door Open..... Door Closed	Open Continuity
 	Secondary Interlock Switch Test (Bottom Switch)	Measure resistance between terminals 1 and 2: Door Open..... Door Closed	Open Continuity
 	Interlock Monitor Switch Test (Middle Switch) Models AMC4080AA*, MMC5080AA* and AMC5193AA*	Measure resistance between terminals 1 and 2: Door Open..... Door Closed	Continuity Open
 	Interlock Monitor Switch Test (Middle Switch) Models AMC5101AA*, MMC5143AA*	Measure resistance between terminals 1 and 2: Door Open..... Door Closed	Continuity Open

Testing Procedures



WARNING

To avoid risk of electrical shock, personal injury or death; disconnect power to oven and discharge the high voltage capacitor before servicing, unless testing requires power.

Illustration	Component	Test Procedure	Results
	Thermal cutout Model AMC4080AA*, MMC5080AA*, MMC5193AA*	Disconnect all wires from TCO. Measure resistance across terminals. Magnetron TCO	Open at 194°F (90°C) and closed at 140°F (60°C)
	Thermal cutout Model AMC5101AA*:	Disconnect all wires from TCO. Measure resistance across terminals. Magnetron TCO	Open at 185°F (85°C) and closed at 167°F (75°C)
	Thermal cutout Model AMC5143AA*:	Disconnect all wires from TCO. Measure resistance across terminals. Magnetron TCO	Open at 302°F (150°C) and closed at 140°F (60°C)
	Thermal cutout Model AMC5143AA*	Disconnect all wires from TCO. Measure resistance across terminals. Cavity TCO	Open at 212°F (100°C) and closed at 32°F (0°C)
	Lamp receptacle	Test continuity of receptacle terminals.	Indicates continuity if bulb is good and screwed in.
	Fan motor Models AMC4080AA*, MMC5080AA*, AMC5101AA*	Remove all wires from motor. Measure resistance across coil.....	Approximately 48 Ω (77°F, 25°C) Less than 44 Ω or more than 54 Ω (70°F, 20°C), motor is defective.
	Fan motor Models AMC5143AA*, MMC5193AA*	Remove all wires from motor. Measure resistance across coil.....	Approximately 46 Ω (70°F, 20°C) Less than 42Ω or more than 50Ω (70°F, 20°C), motor is defective.
	Auto Cook Test (Sensor Only) Models AMC5143AA* and MMC5193AA*	Place 1/3 cup water in oven, then press POPCORN.	After 1-2 minutes, unit beeps and display counts down. Press CLEAR/OFF. If test fails, continue with Sensor Test.
	Sensor Test Models AMC5143AA* and MMC5193AA*	Press SENSOR REHEAT and AUTO DEFROST at the same time.	Numbers displayed at Touch Pad: 15-185 is normal. 185 or higher, sensor open. 15 or lower, sensor shorted.
	Turntable Drive Motor	Measure across terminals	Voltage: Approximately 20 VAC Resistance: Approximately 165 Ω
Refer to Parts Manual for proper power cord part number.	Power cord	Measure resistance of wires.	Continuity should be indicated on each wire. Verify polarity and grounding.

Testing Procedures



WARNING

To avoid risk of electrical shock, personal injury or death; disconnect power to oven and discharge the high voltage capacitor before servicing, unless testing requires power.

Illustration	Component	Test Procedure	Results		
			Pad	Trace	Measurement
	Touch Pad/Control Panel Model AMC4080AA* 	Removal of Touch Pad/Control Panel is required to perform test. Check for continuity.	1 2 3 4 5 6 7 8 9 0 Popcorn Potato One Minute+ Beverage Pizza Reheat Fresh Veg Frozen Dinner Power Level Auto Defrost Clock Pause/Cancel Start	12 & 2 12 & 3 12 & 4 12 & 5 13 & 1 13 & 2 13 & 3 13 & 4 13 & 5 12 & 1 9 & 5 12 & 6 10 & 3 13 & 7 10 & 6 12 & 7 13 & 6 9 & 1 10 & 4 10 & 5 10 & 2 10 & 1	Continuity Continuity
	Touch Pad/Control Panel Model MMC5080AA 	Removal of Touch Pad/Control Panel is required to perform test. Check for continuity.	1 2 3 4 5 6 7 8 9 0 Popcorn Potato One Minute+ Fresh Veg Single Entrée Beverage Pizza Reheat Power Level Kitchen Timer Pizza Reheat Power Level Auto Defrost Clock Kitchen Timer Sound Pause/Cancel Start	12 & 2 12 & 3 12 & 4 12 & 5 12 & 6 13 & 1 13 & 2 13 & 3 13 & 4 12 & 1 9 & 3 9 & 4 9 & 2 9 & 6 9 & 7 13 & 5 11 & 7 10 & 4 10 & 3 11 & 2 11 & 3 11 & 4 11 & 1 9 & 1	Continuity Continuity

Testing Procedures



WARNING

To avoid risk of electrical shock, personal injury or death; disconnect power to oven and discharge the high voltage capacitor before servicing, unless testing requires power.

Illustration	Component	Test Procedure	Results		
			Pad	Trace	Measurement
	<p>Touch Pad/Control Panel Model MMC5193AA*</p>	<p>Removal of Touch Pad/Control Panel is required to perform test. Check for continuity.</p>	1	15 & 2	Continuity
			2	15 & 3	Continuity
			3	15 & 4	Continuity
			4	15 & 5	Continuity
			5	15 & 6	Continuity
			6	14 & 1	Continuity
			7	14 & 2	Continuity
			8	14 & 3	Continuity
			9	14 & 4	Continuity
			0	15 & 1	Continuity
			Sensor Reheat	11 & 2	Continuity
			Auto Defrost	12 & 2	Continuity
			One Minute+	11 & 3	Continuity
			Popcorn	10 & 1	Continuity
			Potato	10 & 2	Continuity
			Pizza Reheat	9 & 6	Continuity
			Fresh Veggies	10 & 5	Continuity
			Frozen Bfast	9 & 1	Continuity
			Frozen Veggies	10 & 6	Continuity
			Frozen Dinner	9 & 2	Continuity
			Handy Helper	13 & 4	Continuity
			Kids Meals	13 & 5	Continuity
			Snack Bar	13 & 6	Continuity
			Power Level	13 & 2	Continuity
			Kitchen Timer	12 & 4	Continuity
			Clock	13 & 3	Continuity
			My Choice	12 & 6	Continuity
			Help	14 & 6	Continuity
			Pause/Cancel	13 & 1	Continuity
			Start	12 & 1	Continuity

Disassembly Procedures

WARNING

High voltage is present at the high voltage terminal of the high voltage transformer during any cooking cycle.

It is neither necessary or advisable to attempt measurement of the high voltage.

Before touching any oven components or wiring, always unplug the oven from its power source and discharge capacitor.

Door Assembly

CAUTION

A microwave leakage test must be performed anytime a door assembly is removed, replaced, disassembled, or adjusted for any reason.

Door Removal

1. Disconnect power to oven and remove outer case, see "Outer Case" procedure.
2. Open the oven door to gain access to the upper hinges. Remove 2 screws securing the upper hinges.
3. Guide the upper hinge out of the hinge cavity.
4. Gently maneuver the door hinge pin away from the lower hinge assembly. Lower hinge bracket should remain attached to the microwave.

NOTE: When aligning the door for assembly, fully open the door.

5. To place the door back on the unit, gently maneuver the lower hinge pin onto the lower hinge assembly while guiding the upper hinge assembly into the upper hinge assembly cavity. Use caution and do not allow the upper hinge assembly to separate from the upper hinge pin. Reattach the two upper hinge assembly retaining screws.

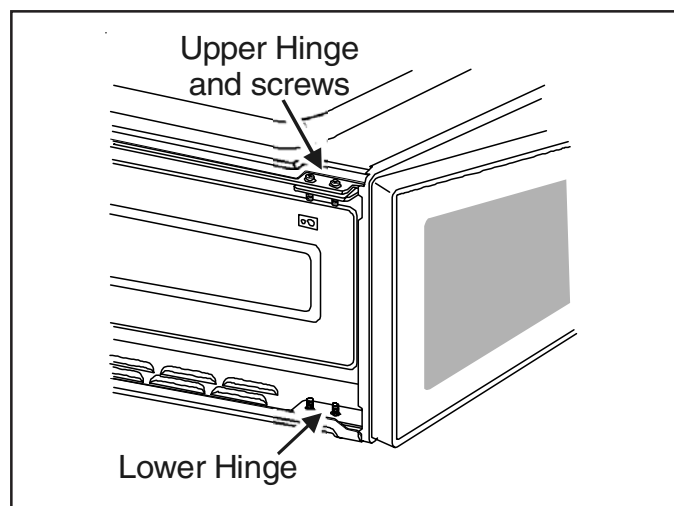

To avoid the risk of electrical shock, personal injury or death; disconnect power to oven and discharge capacitors before following any disassembly procedure.

Door Disassembly

1. Disconnect power to oven and remove oven door, see "Door Removal" procedure.
2. To remove the choke cover, locate one of the plastic seatings securing the choke cover to the inner door assembly. Insert a tool near the seating and gently pry outward. Continue to work around the door casing (prying near the plastic seatings) until choke cover is completely loose. Remove the choke cover.

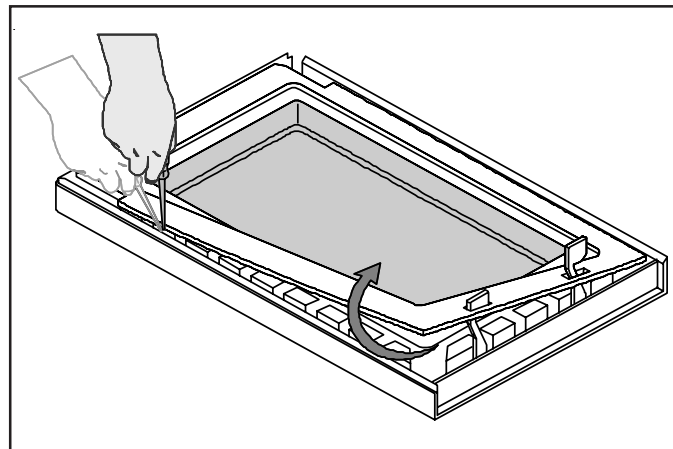

CAUTION

To avoid property damage, care must be taken when prying choke cover from inner door assembly and when prying inner door assembly from door frame.

3. Once the choke cover is removed, remove the inner door assembly.
4. To remove the inner door assembly, carefully pry on the seatings securing the inner door assembly to the door frame. Continue to work around the door casing (prying near the plastic seatings) until the inner door assembly is completely loose. Remove the inner door assembly.
5. Once the inner door assembly is removed, the door latch and spring assembly may be removed.
6. When removing door latch and spring assembly, remove the spring first, then slide latch assembly up and remove.
7. Reassemble in reverse order.

Disassembly Procedures

WARNING

To avoid the risk of electrical shock, personal injury or death; disconnect power to oven and discharge capacitors before following any disassembly procedure.

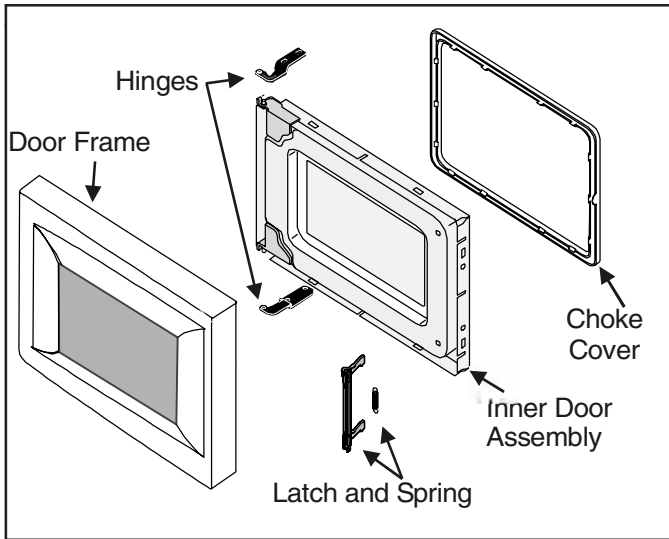

CAUTION

A microwave leakage test must be performed anytime a door assembly is removed, replaced, disassembled, or adjusted for any reason.

Outer Case

1. Disconnect power to unit.
2. Remove screws securing outer case to the unit.
3. Slide outer case towards the rear of the unit, then up.
4. Place outer case in a safe location to prevent damage.
5. Reassemble in reverse order.

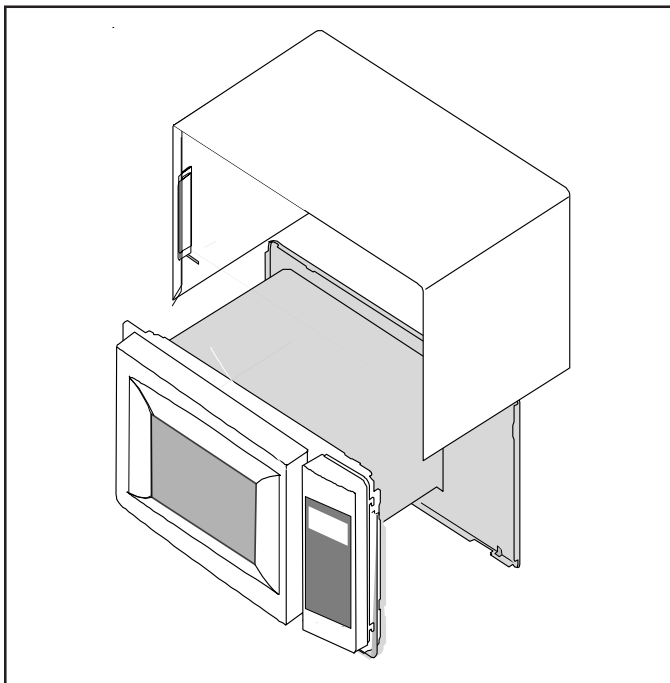

Control Panel

The control panel is made up of several components, such as p.c. board and touch panel.

Control Panel Removal

1. Disconnect power to unit and remove outer case, see "Outer Case" procedure.
2. Open microwave door.
3. Remove screw securing ground strap to microwave frame.
4. Remove screws located at the top and along the side of the touch panel. Remove the screw securing the ground strap, then open the door. Lift control panel up and out to release bottom tab connections.

CAUTION

Hold ground strap secure when removing or attaching screw. Place the green wire under the ribbon strap.

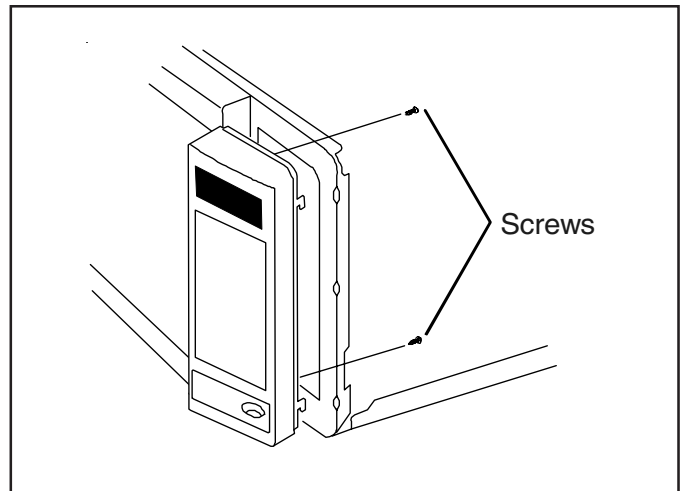

5. Place control panel on a flat surface.
6. Reassemble in reverse order.

Disassembly Procedures

WARNING

To avoid the risk of electrical shock, personal injury or death; disconnect power to oven and discharge capacitors before following any disassembly procedure.

P.C. Board

The p.c. board is located on the back of the control panel near the top. This board has up to five connection plugs which control the main power, relays and the ribbon connector for the key panel.

P.C. Board Removal

1. Disconnect power to unit and remove outer case, see "Outer Case" procedure.
2. Remove control panel, see "Control Panel" procedure.
3. Discharge high voltage capacitor, see "High Voltage Capacitor" procedure.
4. Disconnect ribbon connector by sliding top part of connector upward. Once released, remove ribbon from connector by sliding side-to-side.

NOTE: Caution should be used when removing cable from connector. Ribbon cable has two holes which the connector locks the ribbon in place.

5. Disconnect / mark wire connectors from P. C. Board.
6. Remove screws securing P. C. Board to control panel assembly.
7. Reassemble in reverse order.

NOTE: Do not flex P. C. Board.

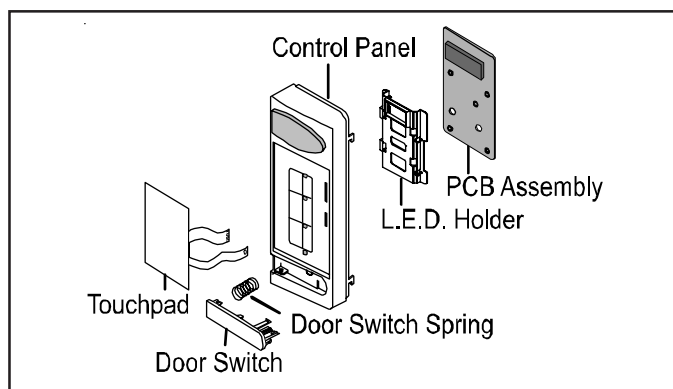

Control Key Panel

The key panel has one ribbon connection on the P. C. Board, and can be checked through a continuity test. Operations of key pad can be checked by measuring connections at end of ribbon (using high ohms scale).

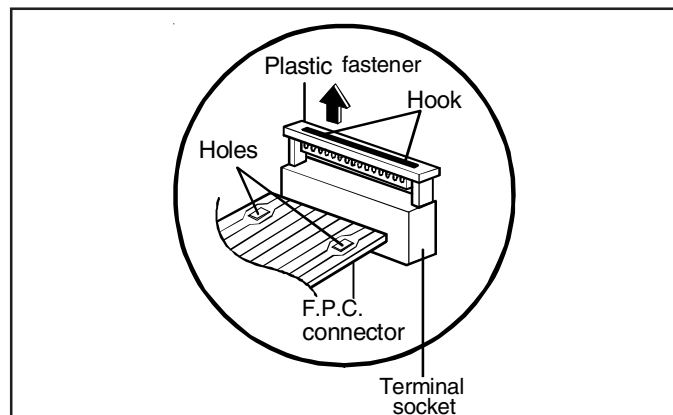

Control Key Panel Removal

1. Disconnect power to unit and remove outer case, see "Outer Case" procedure.
2. Remove control panel, see "Control Panel" procedure.
3. Discharge high voltage capacitor, see "High Voltage Capacitor" procedure.
4. Disconnect ribbon connector by sliding connector upward. Once in released position, remove ribbon from connector by sliding side-to-side.

NOTE: Caution should be used when removing cable from connector. Ribbon cable has two holes which connector locks ribbon in place.

5. Reassemble in reverse order.

Interlock Door Latch Switches

Primary switch is operated by top latch pawl.

Interlock Switch Removal

1. Disconnect power to unit and remove outer case, see "Outer Case" procedure.
2. Remove control panel, see "Control Panel" procedure.
3. Discharge high voltage capacitor, see "High Voltage Capacitor" procedure.
4. Test interlock switches before removing, see "Testing Procedures."
5. Disconnect and label wire connections.
6. Remove interlock switch or latch board assembly by applying pressure to both sides of the switch mounting tabs (two near the front, two near the rear).
7. Gently remove the switch mechanism.
8. Reassemble in reverse order.

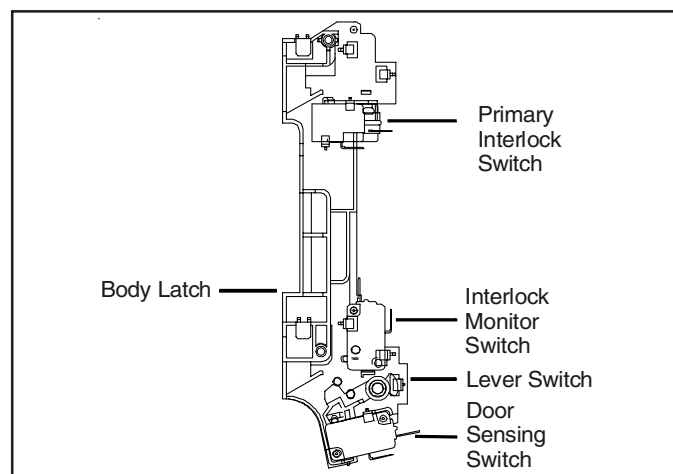

CAUTION

Before replacing a blown monitor fuse, test both interlock switches, monitor switch and power relay contacts for proper operation. If the monitor fuse is blown by a failed switch operation, all switches and the printed circuit board must be replaced.

Disassembly Procedures



WARNING

To avoid the risk of electrical shock, personal injury or death; disconnect power to oven and discharge capacitors before following any disassembly procedure.

Adjusting Interlocks

The interlock monitor, primary, and secondary switches act as a final safety switch protecting the operator from microwave energy. After adjusting the interlock monitor switches, verify they are correctly connected.

For door fit and switch operation, switch housing is adjustable.

1. Disconnect power to unit and remove outer case, see "Outer Case" procedure.
2. Remove control panel, see "Control Panel" procedure.
3. Loosen switch mounting screw on vertical flange.
4. Close oven door, move latch board upward toward the top of the oven and/or away from the door latch until gaps are less than $\frac{1}{6}$ -inch (0.5 mm).
5. Hold latch board securely for proper switch operation and door fit, retighten screws.
6. Open the oven door slowly, watching the switches. Verify switches release in the following order.
 - Primary interlock switch
 - Secondary interlock switch
 - Interlock monitor switch

NOTE: Adjust the latch board until all switches operate in proper sequence.

7. Close the oven door slowly, watching the switches. Verify switches activate in the following order.

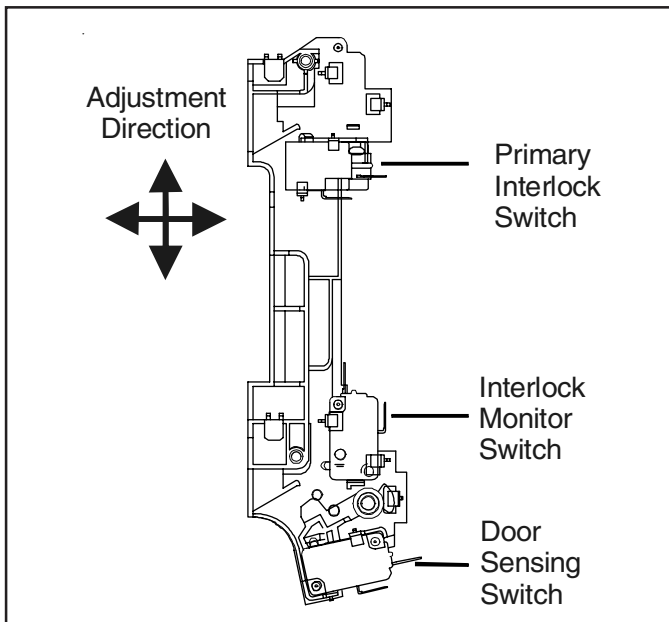

High Voltage Capacitor

High voltage capacitor should always be discharged by shorting a terminal to a chassis ground. The capacitor has a internal "shunt" resistor, but the mechanical discharge should always be performed to avoid personal injury.

High Voltage Capacitor Removal

1. Disconnect power to unit and remove outer case, see "Outer Case" procedure.
2. Discharge the high voltage capacitor by connecting a jumper wire to the terminal of the high voltage capacitor with the diode connection. Connect the opposite end of the jumper wire to a well insulated screwdriver and touch the screwdriver to the nearest chassis ground screw.
3. Remove screws securing capacitor bracket.
4. Slide capacitor mounting bracket out of the slots and pull outward on capacitor, diode and bracket.
5. Reassemble in reverse order.

Diode

The diode is located next to the high voltage capacitor.

1. Disconnect power to unit and remove outer case, see "Outer Case" procedure.
2. Discharge high voltage capacitor, see "High Voltage Capacitor" procedure.
3. Disconnect diode wire terminal from high voltage capacitor and remove screw securing diode to ground.
4. Reassemble in reverse order.

Transformer

Power Transformer Removal

1. Disconnect power to unit and remove outer case, see "Outer Case" procedure.
2. Discharge high voltage capacitor, see "High Voltage Capacitor" procedure.
3. Disconnect and label wire leads from transformer.
4. From bottom of unit, access and remove screws securing transformer.
5. Remove transformer.
6. Reassemble in reverse order.

Disassembly Procedures

WARNING

To avoid the risk of electrical shock, personal injury or death; disconnect power to oven and discharge capacitors before following any disassembly procedure.

Fuse

Fuse is located in line with the power cord.

1. Disconnect power to unit and remove outer case, see "Outer Case" procedure.
2. Remove and replace fuse, reassemble in reverse order.

CAUTION

Before replacing a blown monitor fuse, test the primary interlock switch, secondary interlock switch, monitor switch, and power relay contacts for proper operation. If the monitor fuse is blown by a failed switch operation all switches and printed circuit board must be replaced.

Magnetron

Magnetron is mounted to the side of the cavity.

1. Disconnect power to unit and remove outer case, see "Outer Case" procedure.
2. Discharge high voltage capacitor, see "High Voltage Capacitor" procedure.
3. Remove screws securing magnetron to the wave guide.
4. Reassemble in reverse order.

NOTE: When replacing the magnetron, the gasket must be in the correct position and in good condition.

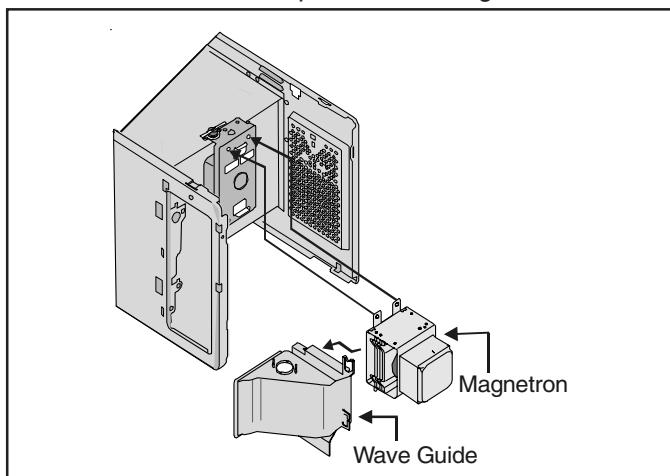

CAUTION

During replacement of magnetron, be certain the R.F. anode gasket is in place around the anode stud.

WARNING

A microwave leakage test must be performed anytime a magnetron assembly is removed, replaced, disassembled or adjusted.

Suction Guide/Fan Motor Assembly

Suction guide assembly also consists of the latch board assembly.

Magnetron fan motor provides cool air circulation from an external air source, which provides direct cool air through air vanes surrounding the magnetron.

1. Disconnect power to unit and remove outer case, see "Outer Case" procedure.
2. Discharge high voltage capacitor, see "High Voltage Capacitor" procedure.
3. Disconnect wire leads from fan motor by depressing dimple on blue connectors, which releases the wire clamp securing the wire to the motor.
4. Remove screws securing cooling fan to oven chassis (screws accessible from the back of the unit).
5. Remove screws securing fan to mounting bracket.

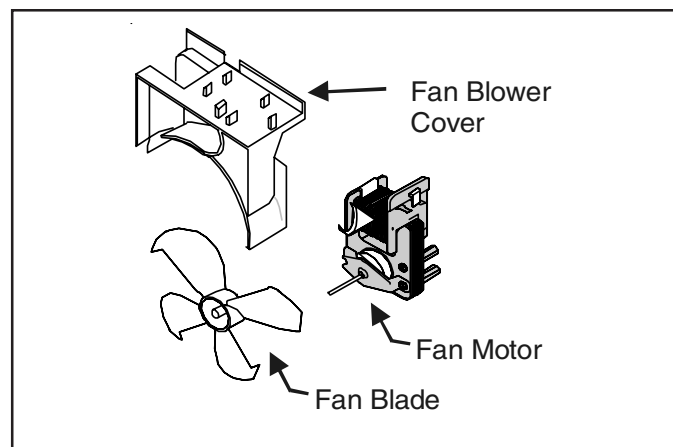

6. Remove screws securing fan motor assembly to bracket.
7. Remove fan blade by gently forcing blade from shaft.
8. Reassemble in reverse order.

Disassembly Procedures

WARNING

To avoid the risk of electrical shock, personal injury or death; disconnect power to oven and discharge capacitors before following any disassembly procedure.

Gas/Humidity Sensor – MMC5080AA*, AMC5143AA* and MMC5193AA*

The sensor is a plug-in device located on the cavity shell near the rear of the unit.

1. Disconnect power to unit and remove outer case, see "Outer Case" procedure.
2. Remove sensor retainer.
3. Disconnect wire terminal retaining plug.
4. Remove/replace sensor.
5. Reassemble in reverse order.

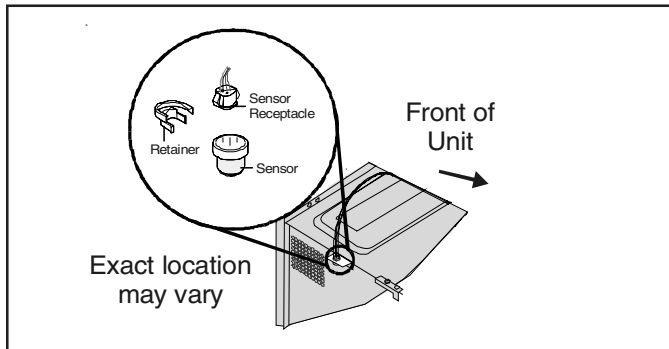

Oven Thermostat

The oven thermostat is located on the top left side of the oven cavity on models AMC5143AA* and MMC5193AA*, top right side of the oven cavity on all other models.

Thermostat is a resettable thermostat.

1. Disconnect power to unit and remove outer case, see "Outer Case" procedure.
2. Disconnect wires.
3. Remove screw securing oven thermostat, slide thermostat out.
4. Reassemble in reverse order.

Light Socket

1. Disconnect power to unit and remove outer case, see "Outer Case" procedure.
2. Disconnect wire terminal plug from light socket.
3. Remove light socket from air duct by pressing together the hold-downs located on the light socket bracket.
4. Remove light bulb.
5. Replace and reassemble in reverse order.

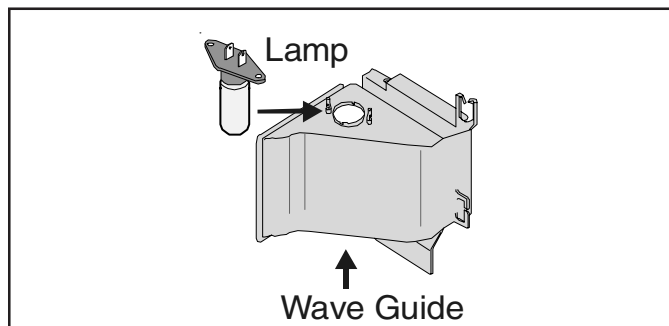

Turntable Motor

1. Disconnect power to oven.
2. Open the oven door, remove turntable, and gently pry upward on turntable shaft cover. During reassembly, locate the half-moon design on the cover, align with the shaft and gently apply pressure.

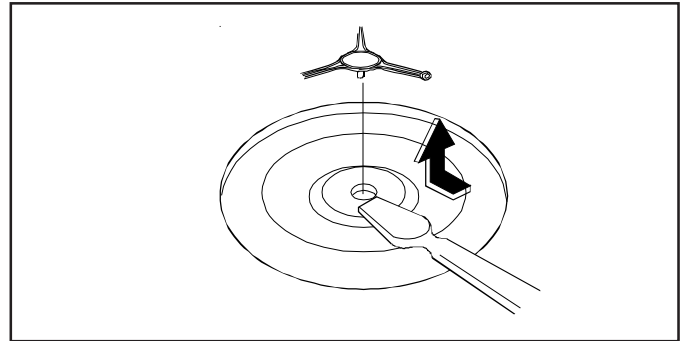

3. Remove bottom plate cover by cutting metal tabs. When reinstalling use the provided screw.

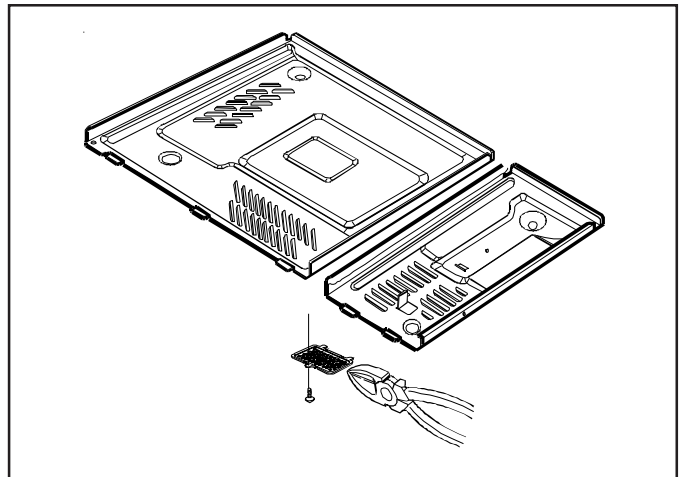

4. Disconnect wire leads from turntable motor.

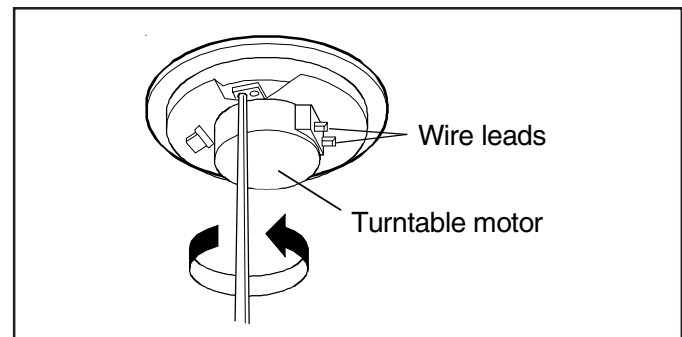

5. Remove screws securing turntable to the oven cavity.
6. Replace and reassemble in reverse order.

Appendix A

Installation Instructions

INSTALLATION INSTRUCTIONS

BUILT-IN KIT MODEL AMC5143AAB/W/Q/S

IMPORTANT: This Built-In Kit is designed for and approved only for those AMANA Microwave Ovens specifying Built-In Kit AMC5143AAB/W/Q/S on rating label on the oven.

CAUTION: THIS OVEN REQUIRES INSTALLATION INTO A CABINET STRUCTURE ONLY. THIS OVEN IS NOT DESIGNED FOR USE IN NON-CABINET INSTALLATIONS OR FREE-STANDING APPLICATIONS ADJACENT TO (WITHIN 2 FEET OF) ANY GAS OR ELECTRIC RANGE, COOKTOP OR OVEN.

The cabinet or wall opening must be within the following dimensions :

WIDTH 22-13/64" to 22-19/64"
 HEIGHT 16-15/16" to 17-1/64"
 DEPTH 15-3/4" minimum

PLEASE READ THESE INSTRUCTIONS THOROUGHLY BEFORE BEGINNING INSTALLATION!

Screw Information	
Part	Specification
Screw-A	TH,+, 2S, M4,L12,IPC(YEL), SM20C
Screw-B	WE,TH,+,M4,L12,IP(YEL),WASHER

NO.	PART NAME PART CODE	Q'TY
1	DUCT UPPER	1
2	DUCT BOTTOM	1
3	DUCT BACK A	1
4	DUCT BACK B	1
5	DUCT-RAIL	2
6	ASSY TRIM	2
7	TRIM -SIDE	2
8	TRIM -CAP(L)	2
9	TRIM -CAP(R)	2
10	SCREW A	4
11	SCREW B	17
12	CUSHION	1(168mm)

※ Be sure to DISCONNECT THE PLUG of the microwave oven from the electrical outlet before installing the built-in kit.
 Remove the turntable tray from the oven cavity, if needed.

Installation Instructions

STEP 1 : CABINET OR WALL OPENING

Provide an opening in the wall or cabinet, as indicated in SKETCH 1.

The depth should be a minimum of 15-3/4". The floor of the opening should be constructed of plywood strong and thick enough to support the weight of the oven <about 50 lbs.> and installation job.

First, punch the 4-holes using the template, Place the Duct-Rail on the Bottom of the Cabinet. Coincide the Duct-Rail holes with the bottom holes of the Cabinet.

Screw the Duct-Rail using Screw B(4EA)

NOTE :

While the proper functioning of the oven does not require that opening be enclosed (with sides, ceiling and rear partition) this may be required by local code, and it is suggested that the local code be checked for any such requirement.

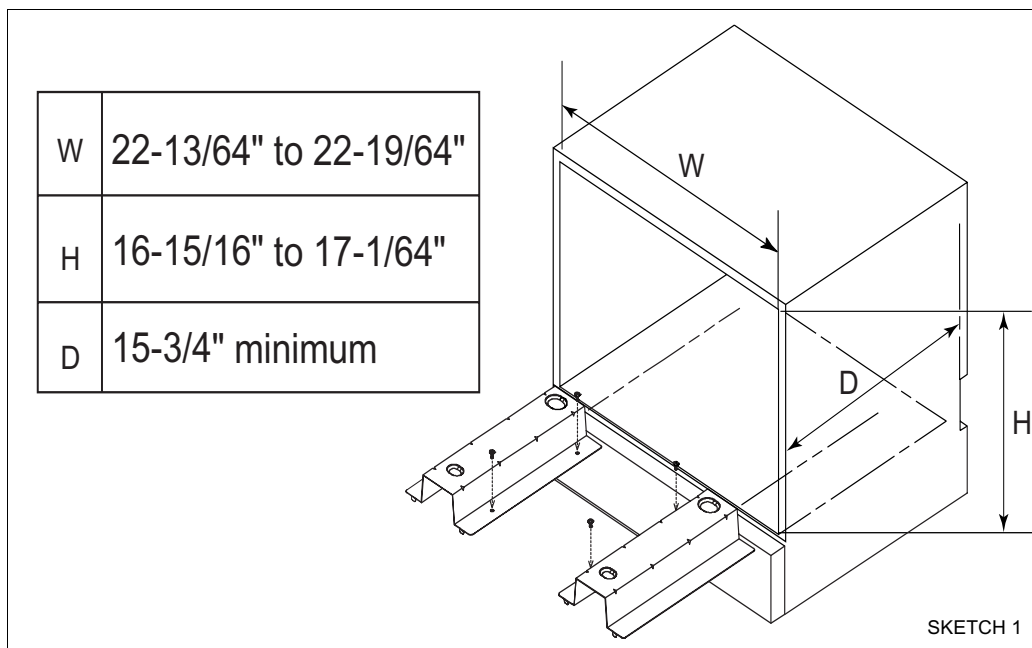

STEP 2 : TRIM ASSEMBLY

Position the ASSY TRIM and SIDES as shown in SKETCH 2.

Make sure that the ASSY TRIM and SIDES are lined up properly to be neat and symmetrical.

Then using Screw B(4EA) , screw the parts together at screw locations shown in SKETCH 2.

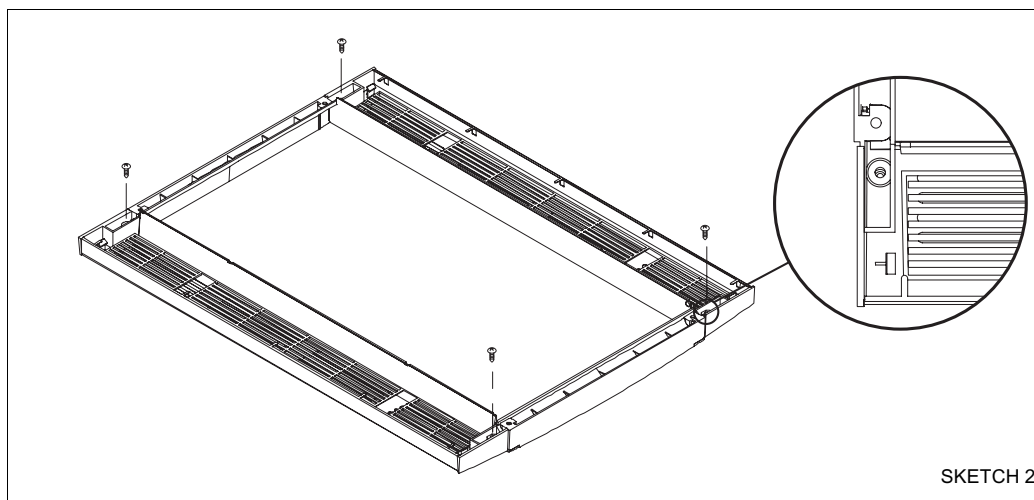

Installation Instructions

STEP 3 : DUCT INSTALLATION

a. Duct Bottom Installation

First, place the oven upside-down.

Attach the DUCT BOTTOM to the oven base using Screw B(4EA) as shown in SKETCH 3.
Carefully return the oven to its original position.

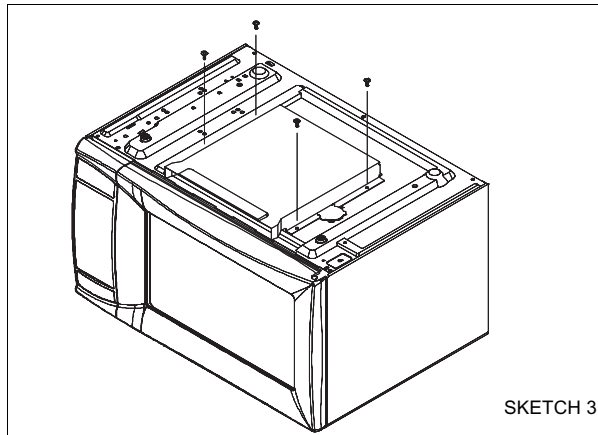

b. Duct Upper & Back A, B Installation

1. First, screw the Duct Upper & Duct Back-A using Screw B(1EA) and remove the Double-side tape of the Duct Upper. Remove the Double-Side tape of the Cushion. Stick it to the Duct Upper & Duct Back-A along the Duct Upper & Duct Back-A. Refer to the SKETCH 4.

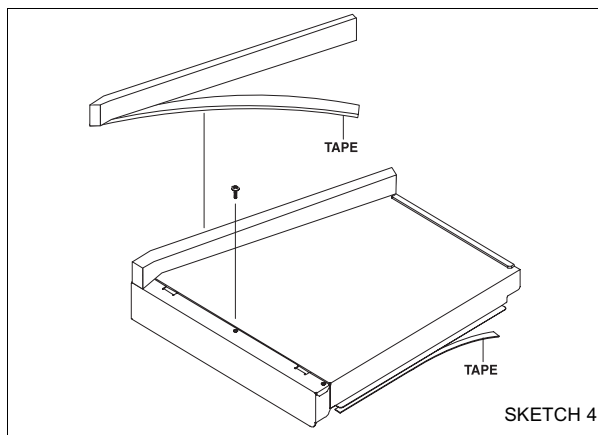

2. Place the Assembled parts(Duct Upper & Duct Back A) on the Microwave Oven in SKETCH 5. Screw the Assembled parts(Duct Upper & Duct Back A) using Screw B(2EA) . Refer to the SKETCH 5.

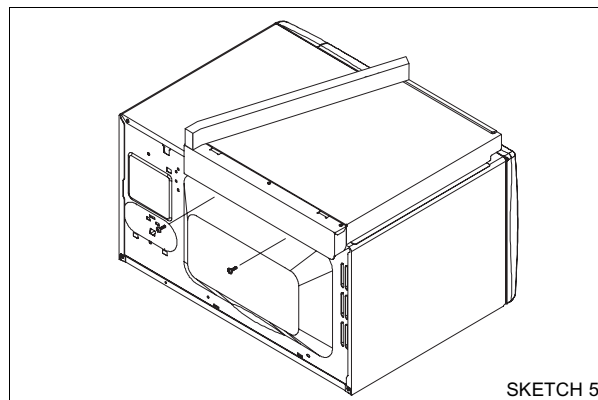

Installation Instructions

3. Unscrew the Outer-Panel screw of position P.

After unscrewing, screw the Duct-Back B using Screw B(2EA) . Refer to the SKETCH 6.

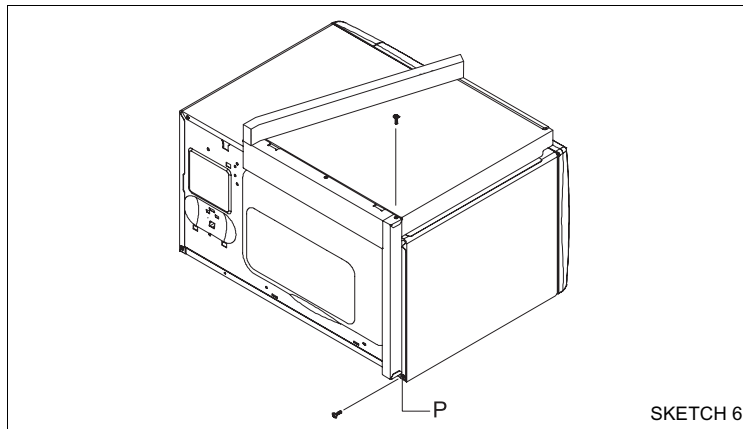

STEP 4 : INSERTION OF MICROWAVE OVEN TO CABINET

Insert the Microwave Oven into the Cabinet and coincide the foot & Duct-Rain foaming holes. Put it on the rail. Refer to the SKETCH 7.

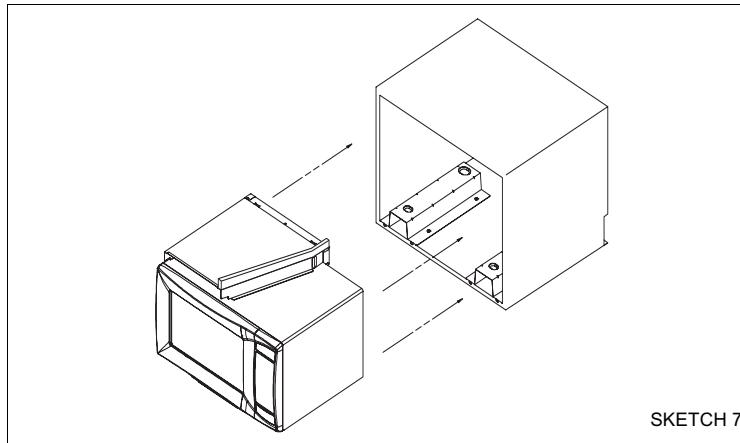

ELECTRIC SUPPLY

PLUG THE THREE-PRONG POWER CORD INTO A PROPERLY GROUNDED OUTLET, 120V, 60Hz.

STEP 5 : INSERTION OF THE TRIM ASSEMBLY

Screw the TRIM ASSEMBLY to the Cabinet using the Screw A(4EA) .

Next, put the TRIM-CAP (R) & (L) . Refer to the SKETCH 8.

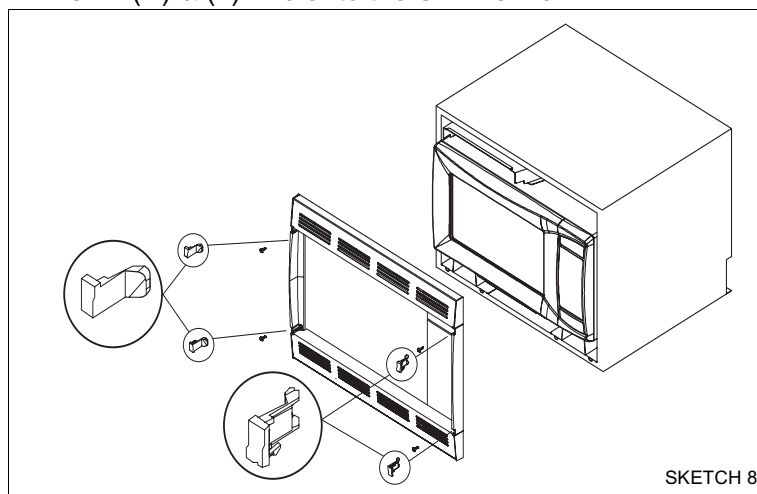

Part No. : 8101P615-60
Code No. : DE68-02898A

Installation Instructions

Models AMC4080AA*, MMC5080AA*

Installation Instructions

READ CAREFULLY. KEEP THESE INSTRUCTIONS.

IMPORTANT SAFETY INSTRUCTIONS

WARNING

Before attempting the installation of this kit, be sure to unplug the oven from wall receptacle.

Your oven is designed to be installed under properly constructed, good condition wood or metal cabinets that are sturdy enough to support the items you have in the cabinet, plus an additional 41 kg (90 pounds) from the cabinet bottom.

Empty the contents of your selected cabinet and the delicate items in adjoining cabinets.

(NOTE: When drilling the holes, the vibration could cause damage to fragile items such as crystal or china.)

Now, you must inspect your cabinets. If any of the following conditions exist, then it is your personal responsibility to test the cabinets or contact a qualified cabinet maker.

1. Separation of joints between the bottom shelf and the cabinet structure.
2. Splitting, cracking or other signs of deterioration.
3. Check the number of screws used to install your cabinets. If your cabinet is attached to the wall with only two screws at the top, then you must add two screws at the bottom to firmly secure your cabinet to the wall. When adding the screws, be sure that they enter wall studs with at least 1.3 cm (1/2") penetration.
4. On wood cabinets, the bottom shelf must be at least .48 cm (3/16") thick masonite or plywood.
5. Be sure that the underside of the cabinet is at least 50 cm (20") wide and 35.0cm (13 25/32") deep. If the cabinet is less than 35.0cm(13 25/32") deep, follow the cabinet mounting instructions carefully if you desire to mount your oven under cabinet. To test your cabinets, place a 40 KG(90LB.) load, plus the equivalent weight of items normally stored on the shelf*, for a minimum of five minutes.

*You may consider using jugs of water, bricks or books to obtain the test load.

PLEASE NOTE: If your cabinet is properly constructed and suitably installed it will withstand this test without any damage; however, there is the possibility of damage should the cabinet be incapable of supporting the additional load.

The Maytag Company is NOT RESPONSIBLE FOR ANY DAMAGE OR OTHER CONSEQUENCES resulting from the performance of this test.

If you are unsure that your cabinets are suitable for this type of installation you may use the oven on your countertop.

TOOLS AND PARTS

The following tools are needed for installation of your unit:

- Drill and .64cm (1/4") drill bit
- Phillips and flat blade screwdrivers
- Nail or center punch
- Pencil and ruler
- Scissors
- Hammer

INSTALLATION PARTS LIST

The following is a list of the parts that you may need for installation of your oven.

Remove all parts from the cooking cavity and compare them with the parts list and illustration to be sure that none are missing. Use this time to become familiar with each piece.

PARTS LIST

1. 3 Sets of bolts
2. 4-washers-A
3. 4-washers-B
4. 1-Template

Upon completing your check of the parts list, read all instructions completely before starting the installation. This will help you to become familiar with the process and make installation easier.

(NOTE: It is suggested that you gather all needed tools and installation parts in one location.)

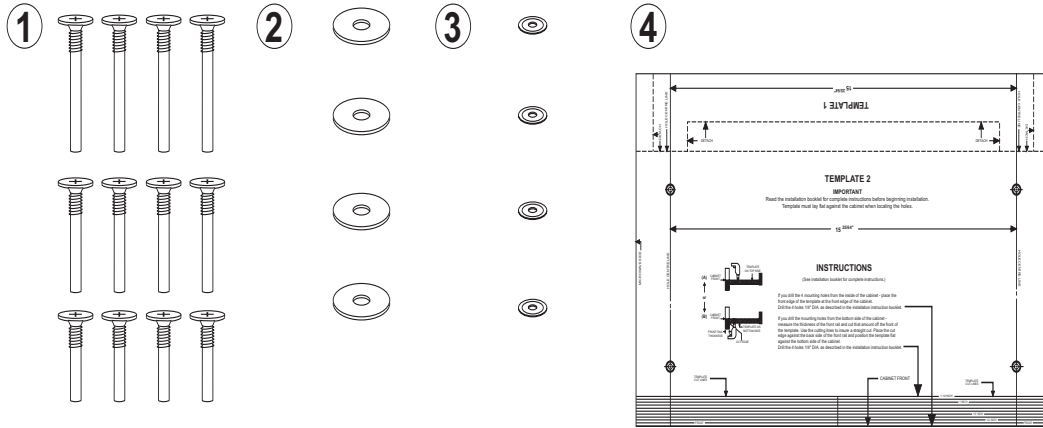

PREPARATIONS

Open the template and detach both segments along the dashed line with scissors. You should have two separate pieces.

- Template 1
- Template 2

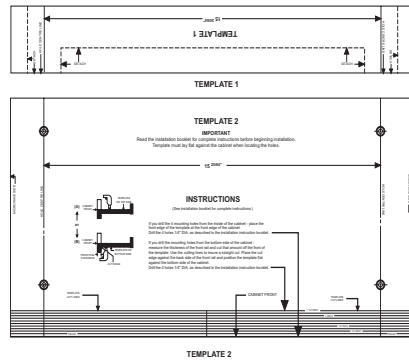

TWO MOUNTING METHODS

There are two mounting methods described in this booklet that can be used.

1. Countertop Method

You can use this method if you decide not to cabinet mount your oven.

To use your oven as a countertop model, simply position the oven on the desired counter and plug the electrical cord into a three prong (grounded) wall receptacle.

2. Cabinet Mounting Method

This method is for mounting your oven under a cabinet and uses the template, 4-washers and one set of screws. Before using this method, the 4 plastic plug buttons on the top of the oven must be removed. This can be done by placing a thin flat blade screwdriver between the plug button and the oven top and raising gently, taking care to avoid scratching the oven top.

OVEN MAY BE MOUNTED TO CABINETS WITH OR WITHOUT A FRONT RAIL.

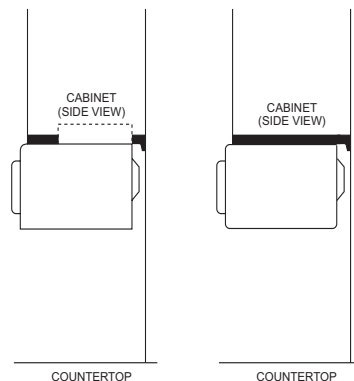

DRILLING APPROACH

You have two options for drilling the mounting holes for your oven.

First, you can drill from inside of the cabinet if you have adequate space and your shelves are removable.

Second, you can drill from the bottom.

If possible, it is generally easier to work from the inside of the cabinet. Use the instructions applicable to the approach you select. Make sure you use the template properly depending whether you drill holes from the inside or bottom side of the cabinet.

INSTRUCTIONS FOR DRILLING FROM INSIDE

If you cannot drill from the inside, go to Instructions for Drilling From Bottom.

1. If your cabinet is less than 35cm(13 25/32") deep, cut off the front edge of Template 2 the amount by which the cabinet depth is less than 35cm(13 25/32"), using the template cut lines as a guide. Place Template 2 inside cabinet. Cut around door jam and if necessary, corners to make template fit.(The front edge of template must be even with the front edge of the cabinet.) Place Template 2 in cabinet.

NOTE: For cabinets with a recessed shelf you must measure the thickness of the front rail and cut that amount off the front edge of Template 2 using the template cut lines as a guide. This will allow Template 2 to lay flat in the shelf.

2. If you have a partition in the cabinet, you must do the following:

- Cut Template 2 into two pieces to fit each side of the partition.
- Position one piece of Template 2 inside the cabinet, making sure that the front edge is even with the front edge of cabinet.
- Position Template 1 on front of the cabinet so that the arrow is aligned with the hole center line on Template 2.

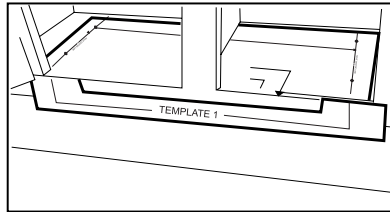

- Position remaining piece of Template 2 inside cabinet and align the hole center lines with arrows on Template 1 so that distance from right hole center to left hole center measures the distance indicated on the template. (You will have to cut excess paper from the middle of Template 2 to make it lay flat.)
- Position the remaining piece of Template 2 inside cabinet.

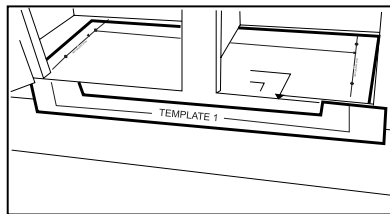

- Check again to make sure that the hole center lines on Template 2 are straight and that the distance from the right to left drilling holes measures the distance indicated on the template.
- Go to Drilling the Mounting Holes.

INSTRUCTIONS FOR DRILLING FROM BOTTOM

1. If you have a front rail, measure the thickness and cut that amount off the front edge of Template 2 using the template cut lines as a guide.

2. Place cut edge of Template 2 against the back side of the front rail and position it flat against the bottom side of the cabinet.

NOTE: On some cabinets a small bracket or glue block is used between the overhang and the underside of the cabinet bottom. If this is true of your cabinets, cut Template 2 to fit around the bracket or glue block so that it will be flat on the cabinet bottom when attached.

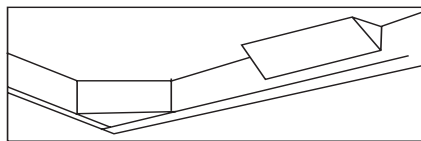

3. If you have a partition you must do the following:

- Cut Template 2 into two pieces to fit on each side of the partition.
- Position one piece of Template 2 under the cabinet. (The cut line along the front edge of Template 2 must be placed against the back of the front rail.)
- Attach Template 1 to rear of cabinet and align arrows with hole center line on Template 2.

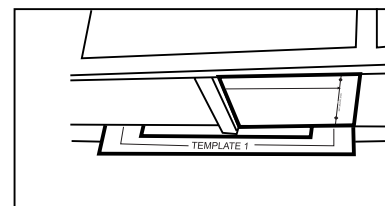

- Position remaining piece of Template 2 under the cabinet and align the hole center lines with arrows on Template 1 so that the distance from right hole center to left hole center measures the distance indicated on the templates. (You may have to cut excess paper from middle of the template to make it lay flat.)
- Position Template 2. (The cut line along the front edge of template must be placed against the back of the front rail.)

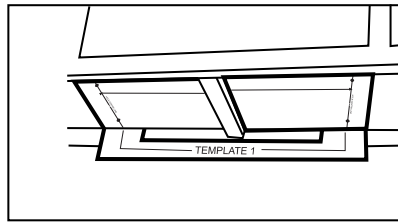

DRILLING THE MOUNTING HOLES

While drilling, it is recommended that safety glasses be worn to prevent possible eye damage from cabinet shavings.

1. Use a center punch or nail to make an indentation for centering the drill bit.
2. Drill through Template 2 at the four black drilling holes indicated on the template. (Drill should be held straight to ensure proper alignment of bolts.)
3. After drilling the four holes, remove the template and clean the drill holes.

SELECTING YOUR MOUNTING BOLTS

1. You should have three sets of bolts of varying lengths in the installation package. select one bolt of each size.
2. Hold each bolt against the cabinet front rail. pick the bolt that extends beyond top of the bottom shelf by 48 cm (3/6") to 2.54 cm (1"). this will be the bolt length needed for your cabinets.

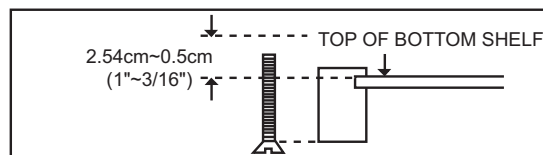

NOTE: It is important to pick the correct bolt length needed for your cabinets. If the bolt is too short it won't reach the oven. If the bolt is too long, it will not permit oven to be drawn up to the cabinet snugly.

3. From inside the cabinet, insert the bolts through the mounting straps and then into the drilled holes.

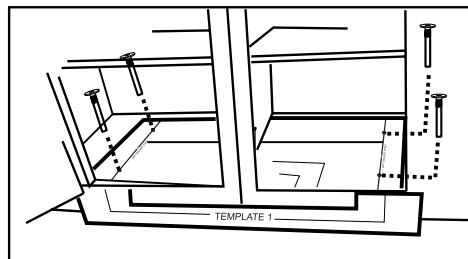

MOUNTING THE OVEN

To aid installation, we suggest that you use some solid support such as books to hold the oven while you are securing it with the mounting bolts.

Make sure that whatever you use is stacked or cut as close as possible to the height needed for the oven to reach the cabinet bottom.

1. Place the oven on the support and move into position. Lift oven, aligning the mounting holes on the oven with the bolts. Do not grip the door handle to help lift the oven.
2. Insert bolts into mounting holes on the oven. Tighten the bolts to secure oven to the bottom of the cabinet. (Alternate between bolts so that oven is drawn up evenly.)
3. Once oven is securely in place, plug power cord into three prong (grounded) wall receptacle.

Appendix B

Programming Instructions for AMC4080AA*

Model AMC4080AA*

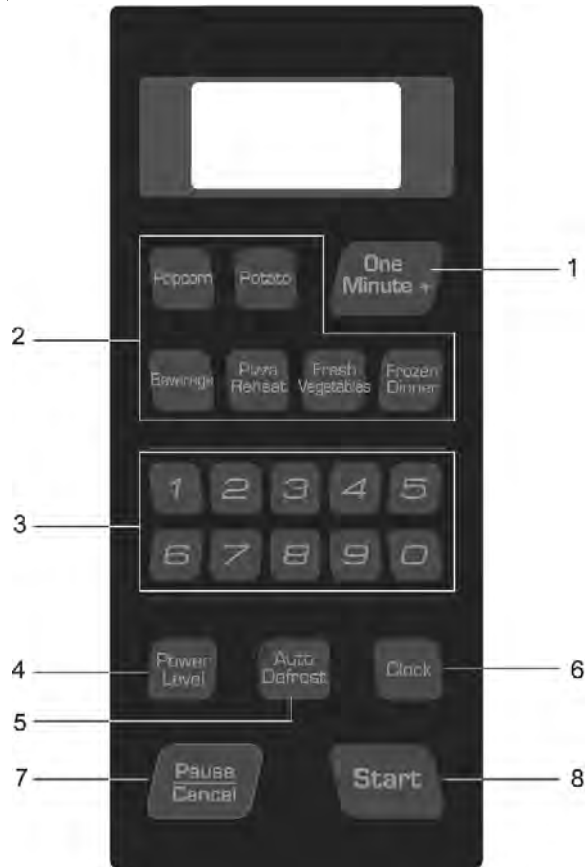

1. One Minute+

Press once for every minute of cooking at High power

2. Instant Cook Buttons

Instant settings to cook popular foods.

3. Number buttons

Sets cooking times.

4. Power Level

Sets power to level other than high.

5. Auto Defrost

Sets weight of the food to be defrosted.

6. Clock

Sets current time.

7. Pause/Cancel

Press to pause oven or correct a mistake.

8. Start

Press to start cooking.

Operation

Setting the Clock

- 1 Press the **Clock** button. The display will show:



- 2 Use the **Number** buttons to enter the current time. You must press at least three numbers to set the clock. If the current time is 5:00 enter, 5,0,0



- 3 Press **Clock** again. A colon will blink, indicating that the time is set. *If there is a power interruption, you will need to reset the clock. You can check the current time while cooking is in progress by pressing the **Clock** button.*

Using the Pause/Cancel Button

The **Pause/Cancel** button allows you to clear instructions you have entered. It also allows you to pause the oven's cooking cycle, so that you can check the food.

- To pause the oven during cooking: press **Pause/Cancel** once. To restart, press **Start**.
- To stop cooking, erase instructions, and return the oven display to the time of day: press **Pause/Cancel** twice.
- To Correct a mistake you have just entered: press **Pause/Cancel** once, then re-enter the instructions.

Using the Instant Cook Buttons

- 1 Press the **Instant Cook** button corresponding to the food you are cooking (**Popcorn**, for example). The display shows the first serving size:



- 2 Press the button repeatedly to select the serving size you want. The display will cycle through all available serving sizes. Once you select the correct serving size, the microwave will begin cooking automatically.



Programming Instructions for AMC4080AA*

Model AMC4080AA*

Instant Cook Chart

Item	Weight	Remarks
Popcorn	3.5 oz 3.0-3.5 oz	<ul style="list-style-type: none"> Use one microwave-only bag of popcorn. Use caution when removing and opening hot bag from oven To help prevent the popcorn bag from getting stuck in the oven, fold each end of the bag up one inch (1") before placing the bag in the center of the oven. If it still gets stuck, open the door and reposition the bag, close the door and press start.
Fresh Vegetable	1 cup 2 cups 3 cups 4 cups	<ul style="list-style-type: none"> Place the vegetable into a casserole and add some water. Cover during cooking and stir before standing.
Frozen Dinner	7-10 oz 10-12 oz	<ul style="list-style-type: none"> Remove package from outerwrapping and follow package instructions for covering and standing. After cooking, let stand 1-3 min.
Potato	1 EA 2 EA 3 EA 4 EA	<ul style="list-style-type: none"> Prick each potato several times with fork. Place on turntable in spoke-like fashion. Remove from oven, wrap in foil and let stand 3-5 min. Once during cooking, the oven will beep to let you know to turn the food over.
Pizza Reheat	1 Slice 2 Slices 3 Slices	<ul style="list-style-type: none"> Put the pizza on a microwave-safe plate with wide end of slice towards the outside edge of the plate. Do not let slices overlap. Do not cover. Before serving, let stand 1-2 min.
Beverage	½ cup 1 cup 2 cups	<ul style="list-style-type: none"> Use measuring cup or mug ; do not cover. Place the beverage in the oven. After heating, stir well.

Using the One Minute+ Button

This button offers a convenient way to heat food in one-minute increments at the High power level.

- 1 Press the **One Minute+** button once for each minute you wish to cook the food. For example, press it twice for two minutes. The time will display, and the oven starts automatically.

*Add minutes to a program in progress by pressing the **One Minute+** button for each minute you want to add.*

Defrosting Automatically

To thaw frozen food, set the weight of the food and the microwave automatically sets the defrosting time, power level and standing time.

- 1 Press the **Auto Defrost** button. The display shows "0.5 lbs." (0.2Kg if you have set your oven for metric measure).
- 2 To set the weight of your food, press the **Auto Defrost** button repeatedly. This increases the weight by 0.5 lb increments, up to 6.0 lbs (The Auto Defrost button will increase the weight by 0.2Kg up to 2.6kg if you are using metric measurement).
You can also use the number buttons to enter the weight of the food directly.
The oven calculates the defrosting time and starts automatically. Twice during defrosting, the oven will beep to let you know to turn the food over.
- 3 Press the **Pause/Cancel** button, open the oven door, and turn the food over.
- 4 Press the **Start** button to resume defrosting.

Setting Cooking Times & Power Levels

Your microwave allows you to set up to two different stages of cooking, each with its own time length and power level. The **power level** button lets you control the heating intensity from Warm (1) to High (0).

One-stage Cooking

For simple one-stage cooking, you only need to set a cooking time. The power level is automatically set to High. If you want to set the power to any other level, you must set it using the **Power Level** button.

- 1 Use the number buttons to set a cooking time. You can set a time from one second to 99 minutes, 99 seconds. To set a time over one minute, enter the seconds too. **For example, to set 20 minutes, enter 2, 0, 0, 0.**

- 2 If you want to set the power level to something other than High, press the **Power Level** button, then use the number buttons to enter a power level.

Power Levels:

1 = PL:10 (Warm)	6 = PL:60 (Simmer)
2 = PL:20 (Low)	7 = PL:70 (Medium High)
3 = PL:30 (Defrost)	8 = PL:80 (Reheat)
4 = PL:40 (Medium Low)	9 = PL:90 (Sauté)
5 = PL:50 (Medium)	0 = PL:Hi (High)

- 3 Press the **Start** button to begin cooking. If you want to change the power level, press **Pause/Cancel** before you press **Start**, and re-enter all of the instructions.

Some recipes require different stages of cooking at different temperatures. You can set multiple stages of cooking with your microwave.

Multi-stage Cooking

- 1 Follow steps 1 and 2 in the "One-Stage Cooking" section on the previous page.

*When entering more than one cooking stage, the **Power Level** button must be pressed before the second cooking stage can be entered.*

*To set the power level at High for a stage of cooking, press the **Power Level** button twice.*

- 2 Use the number buttons to set a second cooking time.
- 3 Press the **Power Level** button, then use the number buttons to set the power level of the second stage of cooking.
- 4 Press **Start** to begin cooking.

*You can check the Power Level while cooking is in progress by pressing the **Power Level** button.*

Programming Instructions for MMC5080AA*

Model MMC5080AA*

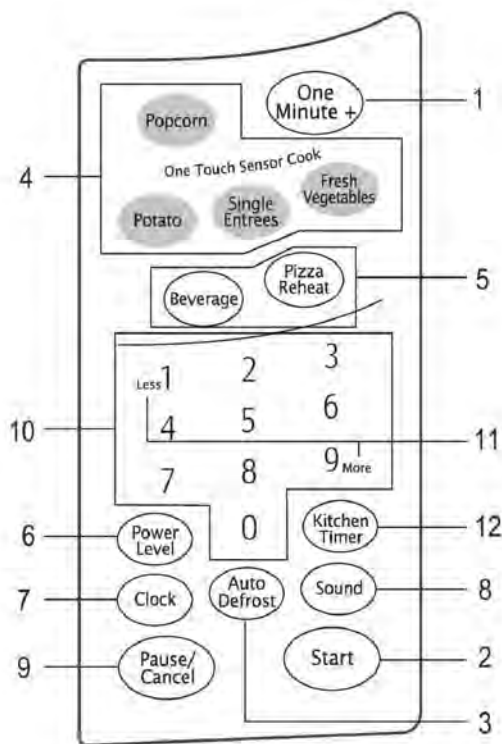

- 1. One Minute+**
Press once for every minute of cooking at High Power
- 2. Start**
Press to start cooking.
- 3. Auto Defrost**
Sets weight of food to be defrosted.
- 4. Sensor Cook Buttons**
- 5. Instant Cook Buttons**
Instant settings to cook popular foods.
- 6. Power Level**
Press this pad to set a power level other than high.
- 7. Clock**
Sets current time.
- 8. Sound Button**
Sets sound on or off.
- 9. Pause/Cancel**
Press to pause oven or correct a mistake.
- 10. Number Buttons**
Sets cooking times or amounts and power levels other than high.
- 11. More/Less**
Increase or decrease cooking time.
- 12. Kitchen Timer**
Sets kitchen or convenience timer.

Turning on the Power and Selecting a Weight

The first time you plug the power cord into an outlet, or after there has been an interruption in power, the display shows "88:88". At this point, you can select the weight system for the display. You can choose between pounds (LBS) or kilograms (KG). To do so,

- 1** Press **0** immediately after plugging in your microwave. The display will show:



If the display does not show "Kg", you will need to unplug the microwave and then plug it in again in order to change to the weight selection.

- 2** Press **0** repeatedly to select the weight system you wish to use:



When you have selected the weight system you want to use, press the **PAUSE/CANCEL** button to end this procedure.

Setting the Clock

- 1** Press the **Clock** button. The "ENTER" and "TIME" indicators flash.
- 2** Use the number buttons to enter the current time. You must press at least three numbers to set the clock. If the current time is 5:00 enter, 5,0,0.
- 3** When 5 seconds has elapsed, "ENTER" indicator flashes and "Cloc" will be displayed.
- 4** Press **Clock** again. A colon will blink, indicating that the time is set.
If there is a power interruption, you will need to reset the clock.
*You can check the current time while cooking is in progress by pressing the **Clock** button.*

Using the Pause/Cancel Button

The **Pause/Cancel** button allows you to clear instructions you have entered. It also allows you to pause the oven's cooking cycle, so that you can check the food.

- To pause the oven during cooking: press **Pause/Cancel** once. To restart, press **Start**.
- To stop cooking, erase instructions, and return the oven display to the time of day: press **Pause/Cancel** twice.
- To correct a mistake you have just entered: press **Pause/Cancel** once, then re-enter the instructions.

Using the One Minute + Button

This button offers a convenient way to heat food in one minute increments at the High power level.

- 1** Press the **One Minute+** button once for each minute you wish to cook the food. For example, press it twice for two minutes. The time will display, and the oven starts automatically.
*Add minutes to a program in progress by pressing the **One Minute+** button for each minute you want to add.*

Using the Instant Cook Buttons

- 1** Press the **Instant Cook** button corresponding to the food you are cooking (**Beverage**, for example). The display shows the first serving size, ("ENTER" and "QTY." will flash).
- 2** Press the button repeatedly to select the serving size you want. The display will cycle through all available serving sizes. Once you select the correct serving size, the microwave will begin cooking automatically.

When the cooking time is over, the oven will beep. The oven will then beep every minute.

Item	Weight	Remarks
Beverage	½ cup 1 cup 2 cups	<ul style="list-style-type: none"> • Use measuring cup or mug; do not cover. • Place the beverage in the oven. • After heating, stir well.
Pizza Reheat	1 Slice 2 Slices 3 Slices	<ul style="list-style-type: none"> • Put the pizza on a microwave-safe plate with wide end of slice towards the outside edge of the plate. • Do not let slices overlap. Do not cover. • Before serving, let stand 1-2 min.

Programming Instructions for MMC5080AA*

Model MMC5080AA*

Using the Sensor Cook Buttons

By actually sensing the steam that escapes as food heats, this feature automatically adjusts the oven's heating time for various types and amounts of precooked food. All food should be precooked and at refrigerator temperature.

- 1 Press the **Sensor Cook** button corresponding to the food you are cooking (**Popcorn**, for example). The display shows "0:00" and your microwave oven will begin cooking automatically.

When cooking popcorn, wait at least five minutes between each bag to avoid overheating the glass tray. If you want to check the current time while cooking is in progress, press the **Clock** button.

Sensor Cooking Guide

- * Follow the instructions below when sensor cooking different types of food.

Food	Amount	Procedure
Potatoes	1 to 6 EA.	Prick each potato several times with fork. Place on turntable in spoke-like fashion. Let stand 3-5 min. Let oven cool for at least 5 minutes before using again.
Fresh Vegetables	1 to 4 cups	Place fresh vegetables in microwave-safe dish and add 2 Tbsp of water. Cover with microwave safe plastic wrap or lid. If using plastic wrap be sure to leave a small opening near the edge of dish for ventilation. Remove vegetable from oven let sit covered for 2 minutes, stir or serve. Let oven cool for at least 5 minutes before using again.
Single Entrees	8 to 14 oz.	Remove food from outer wrapping and follow box instructions for covering and standing. Let oven cool for at least 5 minutes before using again.
Popcorn	3.0 ~ 3.5 oz 1 package	Use only one microwave-only bag of popcorn at a time. Use caution when removing and opening hot bag from oven. Let oven cool for at least 5 minutes before using again. To help prevent the popcorn bag from getting stuck in the oven, fold each end of the bag up one inch () before placing the bag in the center of the oven.

Defrosting Automatically

To thaw frozen food, set the weight of the food and the microwave automatically sets the defrosting time, power level and standing time.

- 1 Press the **Auto Defrost** button. The display shows "0.5 lbs." (0.2Kg if you have set your oven for metric measure). ("ENTER" and "Lbs." will flash).
- 2 To set the weight of your food, press the **Auto Defrost** button repeatedly. This increases the weight by 0.5 lb increments, up to 6.0 lbs (The Auto Defrost button will increase the weight by 0.2Kg up to 2.6kg if you are using metric measurement).

You can also use the number buttons to enter the weight of the food directly.

The oven calculates the defrosting time and starts automatically. Twice during defrosting, the oven will beep to let you know to turn the food over.
- 3 Press the **Pause/Cancel** button, open the oven door, and turn the food over.
- 4 Press the **Start** button to resume defrosting.

- * See page 16 for the Auto Defrosting Guide.

Using the Kitchen Timer

- 1 Press the **Kitchen Timer** button.
- 2 Use the **Number** buttons to set the length of time you want the timer to run.
- 3 Press **Start** to begin Kitchen Timer.
- 4 The display counts down and beeps when the time has elapsed.
Note: The microwave does not turn on when the Kitchen timer is used.

Setting the Child Protection Lock

You can lock your microwave oven so it can't be used by unsupervised children.

- 1 Hold the "0" button and then press the **2** button. The display shows "Loc".

At this point, the microwave oven cannot be used until it is unlocked. To unlock it, repeat step 1 above.

Setting Cooking Times & Power Levels

Your microwave allows you to set up to two different stages of cooking, each with its own time length and power level. The power level button lets you control the heating intensity from Warm (1) to High (0).

One-stage Cooking

For simple one-stage cooking, you only need to set a cooking time. The power level is automatically set to High. If you want to set the power to any other level, you must set it using the **Power Level** button.

- 1 Use the number buttons to set a cooking time. You can set a time from one second to 99 minutes, 99 seconds. To set a time over one minute, enter the seconds too. **For example, to set 20 minutes, enter 2, 0, 0.**
- 2 If you want to set the power level to something other than High, press the **Power Level** button, then use the number buttons to enter a power level.

Power Levels:

1 = PL:10 (Warm)	6 = PL:60 (Simmer)
2 = PL:20 (Low)	7 = PL:70 (Medium High)
3 = PL:30 (Defrost)	8 = PL:80 (Reheat)
4 = PL:40 (Medium Low)	9 = PL:90 (Sauté)
5 = PL:50 (Medium)	0 = PL:Hi (High)

- 3 Press the **Start** button to begin cooking. If you want to change the power level, press **Pause/Cancel** before you press **Start**, and re-enter all of the instructions.

Some recipes require different stages of cooking at different temperatures. You can set multiple stages of cooking with your microwave.

Multi-stage Cooking

- 1 Follow steps 1 and 2 in the "One-Stage Cooking" section on the previous page.

When entering more than one cooking stage, the **Power Level** button must be pressed before the second cooking stage can be entered.

To set the power level at High for a stage of cooking, press the **Power Level** button twice.
- 2 Use the number buttons to set a second cooking time.
- 3 Press the **Power Level** button, then use the number buttons to set the power level of the second stage of cooking.
- 4 Press **Start** to begin cooking.

You can check the Power Level while cooking is in progress by pressing the **Power Level** button.

Using the More/Less Buttons

The **More/Less** buttons allow you to adjust pre-set cooking times. They only work in the **Instant**, **Time Cook** modes. Use the **More/Less** button only after you have already begun cooking with one of these procedures.

The **More/Less** feature cannot be used with the **Sensor Cook** button.

- 1 To ADD more time to an automatic cooking procedure: Press the **More(9)** button.
- 2 To REDUCE the time of an automatic cooking procedure: Press the **Less(1)** button.

If you wish to increase/decrease in **Time Cook** mode by 10 sec, press the **More(9)** or **Less(1)** button.

Switching the Beeper On/Off

You can switch the beeper off whenever you want.

- 1 Press the **Sound** button. The display shows "ON". ("START" will flash)
- 2 Press the **Sound** button to turn the volume off. The display shows: "OFF". ("START" will flash)
- 3 Press **Start**.
The display returns to the time of day.

Demonstration Mode

You can use the Demonstration Mode to see how your microwave oven operates without the oven heating.

- 1 Hold the **0** button and then press the **1** button.
To turn demo mode off, repeat step 1 above.

Programming Instructions for AMC5101AA*

Model AMC5101AA*

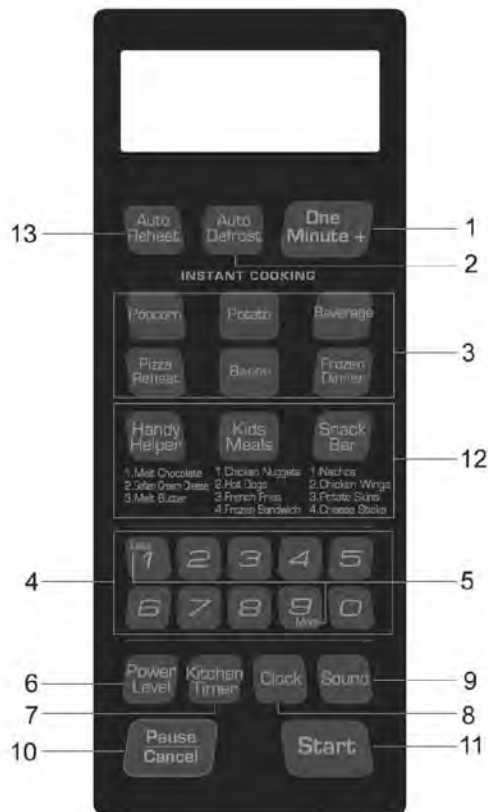

- 1. One Minute+**
Press once for every minute of cooking at High Power
- 2. Auto Defrost**
Sets weight of food to be defrosted.
- 3. Instant Cook Buttons**
Instant settings to cook popular foods.
- 4. Number Buttons**
Sets cooking times or amounts and power levels other than high.
- 5. More/Less**
Increase or decrease cooking time.
- 6. Power Level**
Press this pad to set a power level other than high.
- 7. Kitchen Timer**
Sets kitchen or convenience timer.
- 8. Clock**
Sets current time.
- 9. Sound Button**
Sets sound on or off.
- 10. Pause/Cancel**
Press to pause oven or correct a mistake.
- 11. Start**
Press to start cooking.
- 12. Handy Helper, Kids Meals, Snack Bar**
Selects type of dish to be reheated.
- 13. Auto Reheat**

Turning on the Power and Selecting a Weight

The first time you plug the power cord into an outlet, or after there has been an interruption in power, the display shows "00:00". At this point, you can select the weight system for the display. You can choose between pounds (LBS) or kilograms (KG). To do so,

- 1** Press **0** immediately after plugging in your microwave. The display will show:



If the display does not show "Kg", you will need to unplug the microwave and then plug it in again in order to change to the weight selection.

- 2** Press **0** repeatedly to select the weight system you wish to use:



When you have selected the weight system you want to use, press the **PAUSE/CANCEL** button to end this procedure.

Setting the Clock

- 1** Press the **Clock** button. The "ENTER" and "TIME" indicators flash.



- 2** Use the number buttons to enter the current time. You must press at least three numbers to set the clock. If the current time is 5:00 enter, 5,0,0.

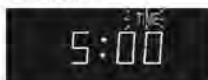

- 3** When 5 seconds has elapsed, "ENTER" indicator flashes and "Cloc" will be displayed.



- 4** Press **Clock** again. A colon will blink, indicating that the time is set. If there is a power interruption, you will need to reset the clock.

You can check the current time while cooking is in progress by pressing the **Clock** button.

Using the Pause/Cancel Button

The **Pause/Cancel** button allows you to clear instructions you have entered. It also allows you to pause the oven's cooking cycle, so that you can check the food.

- To pause the oven during cooking: press **Pause/Cancel** once. To restart, press **Start**.
- To stop cooking, erase instructions, and return the oven display to the time of day: press **Pause/Cancel** twice.
- To correct a mistake you have just entered: press **Pause/Cancel** once, then re-enter the instructions.

Programming Instructions for AMC5101AA*

AMC5101AA*

Using the Instant Cook Buttons

- 1 Press the **Instant Cook** button corresponding to the food you are cooking (**Popcorn**, for example). The display shows the first serving size. ("ENTER" and "QTY." will flash):



- 2 Press the button repeatedly to select the serving size you want. The display will cycle through all available serving sizes. Once you select the correct serving size, the microwave will begin cooking automatically.



When the cooking time is over, the oven will beep. The oven will then beep every minute.

Instant Cook Chart

Item	Weight	Remarks
Popcorn	Regular (3.5 oz), Light Regular (3.0-3.5 oz)	<ul style="list-style-type: none"> • Use one microwave-only bag of popcorn. Pop only one bag at a time. • Use caution when removing and opening hot bag from oven.
Potato	1 EA, 2 EA 3 EA, 4 EA 5 EA, 6 EA	<ul style="list-style-type: none"> • Prick each potato several times with fork. • Place on turntable in spoke-like fashion. • Remove from oven, wrap in foil and let stand 3-5 min.
Beverage	½ cup 1 cup 2 cups	<ul style="list-style-type: none"> • Use measuring cup or mug ; do not cover. • Place the beverage in the oven. • After heating, stir well.
Frozen Dinner	8-10 oz 10-12 oz 12-18 oz	<ul style="list-style-type: none"> • Remove package from outer wrapping and follow package instructions for covering and standing. • After cooking, let stand 1-3 minutes.
Pizza Reheat	1 Slice 2 Slices 3 Slices	<ul style="list-style-type: none"> • Put the pizza on a microwave-safe plate with wide end of slice towards the outside edge of the plate. • Do not let slices overlap. Do not cover. • Before serving, let stand 1-2 min.
Bacon	2 Slices 4 Slices 6 Slices	<ul style="list-style-type: none"> • Place 2 paper towels on plate and arrange bacon on towels, do not overlap. Cover with additional paper towel. Remove paper towel immediately after cooking. • Use More or Less button for desired crispness.

Using the One Minute + Button

This button offers a convenient way to heat food in one-minute increments at the High power level.

- 1 Press the **One Minute +** button once for each minute you wish to cook the food. **For example, press it twice for two minutes.** The time will display, and the oven starts automatically.

*Add minutes to a program in progress by pressing the **One Minute +** button for each minute you want to add.*

Using the Handy Helper Button

1. Press the **Handy Helper** button corresponding to the food you are cooking. The display shows "A-1".(code of item) Press the **Handy Helper** button repeatedly to select the item you want.(Refer to the **Handy Helper Chart** below)
2. Press the **Number** button to select the serving size you want. You can press "1" or "2" buttons for selecting serving size. Only the "1" button(serving) is available for Soften Cream Cheese and Melt Chocolate.(Refer to the **Handy Helper Chart** below for the serving)
3. Press **Start** button to begin cooking.

Handy Helper Chart

Item	Code	Weight	Remarks
Melt Chocolate	A-1	1 cup chips	<ul style="list-style-type: none"> • Place chocolate chips or square in a microwave-safe dish. • Stir well at half time when the oven beeps, and re-start the oven. • Unless stirred, the chocolate keeps its shape even when heating time is over.
Soften Cream Cheese	A-2	1 package (8 oz.)	<ul style="list-style-type: none"> • Unwrap cream cheese and place on microwave-safe dish. • Let stand 1-2 min.
Melt Butter	A-3	1 stick (1/4 lb.) 2 sticks (1/2 lb.)	<ul style="list-style-type: none"> • Remove wrapping and cut butter in half vertically. • Place butter in dish, cover with wax paper. • Stir well after finishing and let stand 1-2 min.

Programming Instructions for AMC5101AA*

Model AMC5101AA*

Using the Kids Meals Button

1. Press the **Kids Meals** button corresponding to the food you are cooking. The display shows "A-1"(Code of item). Press the **Kids Meals** button repeatedly to select the item you want (Refer to the **Kids Meals Chart** below)
2. Press the **Number** button to select the serving size you want. You can press "1" or "2" buttons for selecting serving size. (Refer to the **Kids Meals Chart** below for the serving.)
3. Press **Start** button to begin cooking.

Kids Meals Chart

Item	Code	Weight	Remarks
Chicken Nuggets	A-1	4-5 oz 6-7 oz	<ul style="list-style-type: none"> Put a paper towel on top of plate and arrange nuggets in spoke fashion on paper towel. Do not cover. Let stand 1 min.
Hot Dogs	A-2	2 EA 4 EA	<ul style="list-style-type: none"> Prick hot dogs, place on plate. When the oven beeps, add buns and re-start the oven.
French Fries	A-3	4-5 oz 6-7 oz	<ul style="list-style-type: none"> Place 2 paper towels on plate and arrange french fries on towels, do not overlap. Blot with additional paper towel after removal from oven.
Frozen Sandwich	A-4	1 EA 2 EA	<ul style="list-style-type: none"> Place frozen sandwich in susceptor "sleeve" (which is in package) and put on plate.

Using the Snack Bar Button

1. Press the **Snack Bar** button corresponding to the food you are cooking. The display shows "A-1".(Code of item) Press the **Snack Bar** button repeatedly to select the item you want (Refer to the **Snack Bar Chart** below)
2. Press the **Number** button to select the serving size you want. You can press "1" or "2" buttons for selecting serving size. Only the "1" button(serving) is available for Nachos. (Refer to the **Snack Bar Chart** below for the serving)
3. Press **Start** button to begin cooking.

Snack Bar Chart

Item	Code	Weight	Remarks
Nachos	A-1	1 serving	<ul style="list-style-type: none"> Place tortilla chips on plate without overlapping. Sprinkle evenly with cheese. Contents : <ul style="list-style-type: none"> - 2 cups tortilla chips - 1/3 cup grated cheese
Chicken Wings	A-2	5-6 oz 7-8 oz	<ul style="list-style-type: none"> Use pre-cooked, refrigerated chicken wings. Place chicken wings around plate in spoke fashion and cover with wax paper.
Potato Skins	A-3	1 cooked potato 2 cooked potatoes	<ul style="list-style-type: none"> Cut cooked potato into 4 even wedges. Scoop or cut out potato flesh, leaving about 1/4" of skin. Place skins in spoke fashion around plate. Sprinkle with bacon, onions and cheese. Do not cover.
Cheese Sticks	A-4	5-6 pcs 7-10 pcs	<ul style="list-style-type: none"> Place cheese sticks on plate in spoke fashion. Do not cover.

Defrosting Automatically

To thaw frozen food, set the weight of the food and the microwave automatically sets the defrosting time, power level and standing time.

- 1 Press the **Auto Defrost** button. The display shows "0.5 lbs." (0.2 Kg if you have set your oven for metric measure) ("ENTER" and "Lbs." will flash).



- 2 To set the weight of your food, press the **Auto Defrost** button repeatedly. This increases the weight by 0.5 lb increments, up to 6.0 lbs (The Auto Defrost button will increase the weight by 0.2kg up to 2.6kg if you are using metric measurement).
You can also use the number buttons to enter the weight of the food directly.
The oven calculates the defrosting time and starts automatically. Twice during defrosting, the oven will beep to let you know to turn the food over.
- 3 Press the **Pause/Cancel** button, open the oven door, and turn the food over.
- 4 Press the **Start** button to resume defrosting.

Setting Cooking Times & Power Levels

Your microwave allows you to set up to two different stages of cooking, each with its own time length and power level. The **power level** button lets you control the heating intensity from Warm (1) to High (0).

One-stage Cooking

For simple one-stage cooking, you only need to set a cooking time. The power level is automatically set to High. If you want to set the power to any other level, you must set it using the **Power Level** button.

- 1 Use the number buttons to set a cooking time. You can set a time from one second to 99 minutes, 99 seconds. To set a time over one minute, enter the seconds too. **For example, to set 20 minutes, enter 2, 0, 0, 0 .**
- 2 If you want to set the power level to something other than High, press the **Power Level** button, then use the number buttons to enter a power level.

Power Levels:

1 = PL:10 (Warm)	6 = PL:60 (Simmer)
2 = PL:20 (Low)	7 = PL:70 (Medium High)
3 = PL:30 (Defrost)	8 = PL:80 (Reheat)
4 = PL:40 (Medium Low)	9 = PL:90 (Sauté)
5 = PL:50 (Medium)	0 = PL:Hi (High)

- 3 Press the **Start** button to begin cooking. If you want to change the power level, press **Pause/Cancel** before you press **Start**, and re-enter all of the instructions.

Some recipes require different stages of cooking at different temperatures. You can set multiple stages of cooking with your microwave.

Programming Instructions for AMC5101AA*

Model AMC5101AA*

Multi-stage Cooking

- 1 Follow steps 1 and 2 in the "One-Stage Cooking" section on the previous page.
*When entering more than one cooking stage, the **Power Level** button must be pressed before the second cooking stage can be entered.*
*To set the power level at High for a stage of cooking, press the **Power Level** button twice.*
- 2 Use the number buttons to set a second cooking time.
- 3 Press the **Power Level** button, then use the number buttons to set the power level of the second stage of cooking.
- 4 Press **Start** to begin cooking.
*You can check the Power Level while cooking is in progress by pressing the **Power Level** button.*

Using the More/Less Buttons





The **More/Less** buttons allow you to adjust pre-set cooking times. They only work in the **Instant**, **Handy Helper**, **Kids Meals**, **Snack Bar** or **Time Cook** modes. Use the **More/Less** button only after you have already begun cooking with one of these procedures.

- 1 To **ADD** more time to an automatic cooking procedure: Press the **More** (9) button.
- 2 To **REDUCE** the time of an automatic cooking procedure: Press the **Less** (1) button.

*If you wish to increase/decrease in **Time Cook** mode by 10 sec, press the **More** (9) or **Less** (1) button.*

Switching the Beeper On/Off

You can switch the beeper off whenever you want.

- 1 Press the **Sound** button. The display shows "ON". ("START" will flash)
 
- 2 Press the **Sound** button to turn the volume off. The display shows: "OFF". ("START" will flash)
 
- 3 Press **Start**.
The display returns to the time of day.

Using the Kitchen Timer

- 1 Press the **Kitchen Timer** button.
 - 2 Use the **Number** buttons to set the length of time you want the timer to run.
 - 3 Press **Start** to begin Kitchen Timer.
 - 4 The display counts down and beeps when the time has elapsed.
- Note:** The microwave does not turn on when the Kitchen timer is used.

Demonstration Mode

You can use the Demonstration Mode to see how your microwave oven operates without the oven heating.

- 1 Hold the **0** button and then press the **1** button.
To turn demo mode off, repeat step 1 above.

Setting the Child Protection Lock

You can lock your microwave oven so it can't be used by unsupervised children.

- 1 Hold the "0" button and then press the **2** button.



At this point, the microwave oven cannot be used until it is unlocked. To unlock it, repeat step 1 above.

Reheating Automatically

To reheat food, select the type of dish and the number of servings you want to reheat, and the microwave automatically sets the reheating time.

- 1 Press the **Auto Reheat** button repeatedly to select the type of dish you wish to reheat. The initial serving size for each dish is one serving.
You can select up to four servings for casseroles and pasta reheat. Only one serving is available for a plate of food.
The display shows the dish and quantity you have chosen.
- 2 Use the number buttons to increase the serving size. **For example, for three servings, press the 3 button (Refer to the Auto Reheat Chart below for the servings).** The display shows the number of servings you have selected:
- 3 Press the **Start** button. The display will show Cooking Time.

Auto Reheat Chart

Item	Weight	Remarks
Plate of food	1 serving	<ul style="list-style-type: none">• Use only pre-cooked, refrigerated foods.• Cover plate with vented plastic wrap or wax paper.• Contents<ul style="list-style-type: none">- 3-4 oz. meat, poultry or fish (up to 6 oz. with bone)- ½ cup starch (potatoes, pasta, rice, etc.)- ½ cup vegetables (about 3-4 oz.)
Casserole	1 to 4 servings (8 oz./serving)	<ul style="list-style-type: none">• Use only refrigerated foods.• Cover with lid or vented plastic wrap.• Stir foods well before serving.
Pasta Reheat	1 to 4 servings (8 oz./serving)	

Programming Instructions for AMC5143AA*

Model AMC5143AA*

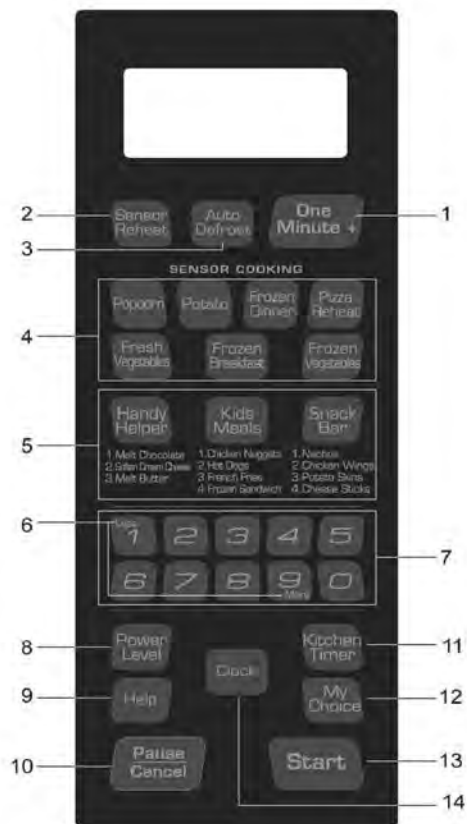

- 1. One Minute +**
Press once for every minute of cooking at High power.
- 2. Sensor Reheat**
- 3. Auto Defrost**
Sets weight of food to be defrosted.
- 4. Sensor Cook Buttons**
Sensor settings to cook popular foods.
- 5. Handy Helper, Kids Meals, Snack Bar**
Selects type of dish to be reheated.
- 6. More/Less**
Increase or decrease cooking time.
- 7. Number Buttons**
Set cooking times or amounts and power levels other than high.
- 8. Power Level**
Press this pad to set a power level other than high.
- 9. Help**
Press to see help information about the feature you are using.
- 10. Pause/Cancel**
Press to pause oven or correct a mistake.
- 11. Kitchen Timer**
Sets kitchen or convenience timer
- 12. My Choice**
Press to set non-cooking feature.
- 13. Start**
Press to start cooking.
- 14. Clock**
Sets current time

Turning on the Power and Selecting a Display Language

The first time you plug the power cord into an outlet, or after there has been an interruption in power, the display shows after four seconds "ENJOY YOUR COOKING --- PRESS MY CHOICE FOR PERSONAL OPTIONS"

- 1** Press **My Choice** immediately after plugging in your microwave. The display will show "PRESS 1-9 TO SELECT VARIOUS OPTIONS".

- 2** Press the "1" button. The display will show:

LANGUAGE CHOICE PRESS MY CHOICE

- 3** Press **My Choice** The display will show:

ENGLISH PRESS START

- 4** Press **My Choice** repeatedly to select the language you wish to use:

- ENGLISH
- FRENCH
- SPANISH

If you continue to press **My Choice**, the settings will cycle in the order shown here:

ENGLISH FRENCH SPANISH

- 5** Press the "Start" button.

Using the My Choice feature

Your new microwave oven can be customized to suit your personal tastes. Simply press **My Choice** to set these options. For your convenience, all the options are summarized in the following table:

My Choice options	Description	Operation
Display Weight	Weight options are pounds or kilograms.	Press My Choice , 2 and select by repeatedly pressing My Choice . To set, press Start .
Adjusting the Volume	Volume options include Off, Low, Medium, High and Melody 1-5.	Press My Choice , 3 and select by repeatedly pressing My Choice . To set, press Start .
Remind End Signal	The Remind End Signal can be turned On and Off.	Press My Choice , 4 and select by repeatedly pressing My Choice . To set, press Start .
Child Protection Lock	This feature prevents use by unsupervised children.	Press My Choice , 5 and select by pressing My Choice . To set, press Start .
Clock 12HR/24HR	The clock can display either 12HR or 24HR time modes.	Press My Choice , 6 and select by repeatedly pressing My Choice . To set, press Start .
Word Prompting Speed	There are five speeds, from Level 1 (slowest) to Level 5 (fastest). Default is Level 3.	Press My Choice , 7 and select by repeatedly pressing My Choice . To set, press Start .
Daylight Savings Time Adjustment	The time can be advanced one hour for DST without resetting the Clock.	Press My Choice , 8 and select by repeatedly pressing My Choice . To set, press Start .
Demonstration Mode	The Demo Mode can be turned On and Off.	Press My Choice , 9 and select by repeatedly pressing My Choice . To set, press Start .

If there is a power interruption, you will need to reset these options.

Programming Instructions for AMC5143AA*

Model AMC5143AA*

Selecting the Display Weight

You can choose between pounds(LBS) and kilograms(KG).

- 1 Press **My Choice** button and then press the **2** button. The display shows "LBS OR KG".



- 2 Press the **My Choice** button repeatedly to select the weight measurements you wish to use.
- 3 Press the **Start** button.

Setting the Clock 12HR/24HR

The time can be displayed in either 24-hour or 12-hour format.

- 1 Press the **My Choice** button and then **6**. The display shows "CLOCK 12HR/24HR OPTION".



- 2 Press the **My Choice** button repeatedly to select either 12HR or 24HR.
- 3 Press the **Start** button.

Setting the Clock

- 1 Press the **Clock** button. The display will show:



- 2 Use the number buttons to enter the current time. You must press at least three numbers to set the clock. For example, if the current time is 5:00, enter 5,0,0.



- 3 Press **Clock** again. A colon will appear, indicating that the time is set.

If there is a power interruption, you will need to reset the clock.

*You can check the current time while cooking is in progress by pressing the **Clock** button.*

Setting the Daylight Saving Time adjustment

- 1 Press the **My Choice** button and then **8**. The Display shows "DAYLIGHT SAVING TIME ON/OFF".



- 2 Press the **My Choice** button to select ON. Press again to select OFF.
- 3 Press the **Start** button. Time of day will advance one hour. If OFF is selected, time will go back one hour.

If the clock is set for standard time, this function allows convenient time changes without needing to reset the clock. Daylight Saving Time begins for most of the United States at 2 a.m. on the first Sunday of April, and reverts to Standard time at 2 a.m. on the last Sunday of October.

Using the Pause/Cancel Button

The **Pause/Cancel** button allows you to clear instructions you have entered. It also allows you to pause the oven's cooking cycle, so that you can check the food.

- To pause the oven during cooking : press **Pause/Cancel** once. To restart, press **Start**.
- To stop cooking, erase instructions, and return the oven display to the time of day: Press **Pause/Cancel** twice.
- To clear instructions you have just entered: press **Pause/Cancel** once, then re-enter the instructions.
- To cancel a timer setting: press **Pause/Cancel** once.

Using the Help Button

Your microwave offers helpful instructions for many procedures.

- 1 When you need feature information and helpful hints, press the **Help** button and then press the button that you want to get information on. Help information is available in 3 languages (English, French and Spanish).

Using the Sensor Cook Buttons

By actually sensing the steam that escapes as food heat, this feature automatically adjusts the oven's heating time for various types and amounts of precooked food. All food should be precooked and at refrigerator temperature.

- 1 Press the **Sensor Cook** button corresponding to the food you are cooking (**Popcorn**, for example). The display shows "POPCORN" and your microwave oven will begin cooking automatically.



When cooking popcorn, wait at least five minutes between each bag to avoid overheating the glass tray. If you want to adjust the cooking time, you can use the **More/Less** buttons. See page 15 for more information. If you want to check the current time while cooking is in progress, press the **Clock** button.

Programming Instructions for AMC5143AA*

Model AMC5143AA*

Using the One Minute + Button

This button offers a convenient way to heat food in one minute increments at the High power level.

- 1 Press the **One Minute+** button once for each minute you wish to cook the food. For example, press it twice for two minutes. The time will display, and the oven starts automatically.

*Add minutes to a program in progress by pressing the **One Minute+** button for each minute you want to add.*

Using the Snack Bar Button

1. Press the **Snack Bar** button corresponding to the food you are cooking. The display shows "Nachos". Press the **Snack Bar** button repeatedly to select the item you want. (Refer to the **Snack Bar Chart** below)
2. Press the **Number** button to select the serving size you want. You can press the "1" or "2" button to select the serving size. Only the "1" button (serving) is available for Nachos. (Refer to the **Snack Bar Chart** below for the serving)
3. Press the **Start** button to begin cooking.

Snack Bar Chart

Item	Weight	Remarks
Nachos	1 serving	<ul style="list-style-type: none">• Place tortilla chips on plate without overlapping.• Sprinkle evenly with cheese.• Contents :<ul style="list-style-type: none">- 2 cups tortilla chips- 1/3 cup grated cheese
Chicken Wings	5-6 oz 7-8 oz	<ul style="list-style-type: none">• Use pre-cooked, refrigerated chicken wings.• Place chicken wings around plate in spoke fashion and cover with wax paper.
Potato Skins	1 cooked potato 2 cooked potatoes	<ul style="list-style-type: none">• Cut cooked potato into 4 even wedges. Scoop or cut out potato flesh, leaving about 1/4" of skin.• Place skins in spoke fashion around plate.• Sprinkle with bacon, onions and cheese. Do not cover.
Cheese Sticks	5-6 pcs 7-10 pcs	<ul style="list-style-type: none">• Place cheese sticks on plate in spoke fashion.• Do not cover.

Defrosting Automatically

To thaw frozen food, set the weight of the food and the microwave automatically sets the defrosting time, power level and standing time.

- 1 Press the **Auto Defrost** button. The display shows "0.5 lbs." (0.2 Kg if you have set your oven for metric measure) ("ENTER" and "Lbs." will flash).



- 2 To set the weight of your food, press the **Auto Defrost** button repeatedly. This increases the weight by 0.5 lb increments, up to 6.0 lbs (The Auto Defrost button will increase the weight by 0.2kg up to 2.6kg if you are using metric measurement).

You can also use the number buttons to enter the weight of the food directly.

The oven calculates the defrosting time and starts automatically. Twice during defrosting, the oven will beep to let you know to turn the food over.

- 3 Press the **Pause/Cancel** button, open the oven door, and turn the food over.
- 4 Press the **Start** button to resume defrosting.

Setting Cooking Times & Power Levels

Your microwave allows you to set up to two different stages of cooking, each with its own time length and power level. The **power level** button lets you control the heating intensity from Warm (1) to High (0).

One-stage Cooking

For simple one-stage cooking, you only need to set a cooking time. The power level is automatically set to High. If you want to set the power to any other level, you must set it using the **Power Level** button.

- 1 Use the number buttons to set a cooking time. You can set a time from one second to 99 minutes, 99 seconds. To set a time over one minute, enter the seconds too. **For example, to set 20 minutes, enter 2, 0, 0, 0 .**

- 2 If you want to set the power level to something other than High, press the **Power Level** button, then use the number buttons to enter a power level.

Power Levels:

1 = PL:10 (Warm)	6 = PL:60 (Simmer)
2 = PL:20 (Low)	7 = PL:70 (Medium High)
3 = PL:30 (Defrost)	8 = PL:80 (Reheat)
4 = PL:40 (Medium Low)	9 = PL:90 (Sauté)
5 = PL:50 (Medium)	0 = PL:Hi (High)

- 3 Press the **Start** button to begin cooking. If you want to change the power level, press **Pause/Cancel** before you press **Start**, and re-enter all of the instructions.

Some recipes require different stages of cooking at different temperatures. You can set multiple stages of cooking with your microwave.

Programming Instructions for AMC5143AA*

Model AMC5143AA*

Using the Handy Helper Button

1. Press the **Handy Helper** button corresponding to the food you are cooking. The display shows "Melt Chocolate". Press the **Handy Helper** button repeatedly to select the item you want. (Refer to the **Handy Helper Chart** below)
2. Press the **Number** button to select the serving size you want. You can press the "1" or "2" button to select the serving size. Only the "1" button (serving) is available for Soften Cream Cheese and Melt Chocolate items. (Refer to the **Handy Helper Chart** below for the serving)
3. Press the **Start** button to begin cooking.

Handy Helper Chart

Item	Weight	Remarks
Melt Chocolate	2 squares or 1 cup chips	<ul style="list-style-type: none"> Place chocolate chips or square in a microwave-safe dish. Stir well at half time when the oven beeps, and re-start the oven.
Soften Cream Cheese	1 package (8 oz.)	<ul style="list-style-type: none"> Unwrap cream cheese and place on microwave-safe dish. Let stand 1-2 min.
Melt Butter	1 stick (1/4 lb.) 2 sticks (1/2 lb.)	<ul style="list-style-type: none"> Remove wrapping and cut butter in half vertically. Place butter in dish, cover with wax paper. Stir well after finishing and let stand 1-2 min.

Using the Kids Meals Button

1. Press the **Kids Meals** button corresponding to the food you are cooking. The display shows "Chicken Nuggets". Press the **Kids Meals** button repeatedly to select the item you want. (Refer to the **Kids Meals Chart** below)
2. Press the **Number** button to select the serving size you want. You can Press the "1" or "2" button to select the serving size. (Refer to the **Kids Meals Chart** below for the serving.)
3. Press the **Start** button to begin cooking.

Kids Meals Chart

Item	Weight	Remarks
Chicken Nuggets	4-5 oz 6-7 oz	<ul style="list-style-type: none"> Put a paper towel on top of plate and arrange nuggets in spoke fashion on paper towel. Do not cover. Let stand 1 min.
Hot Dogs	2 EA 4 EA	<ul style="list-style-type: none"> Prick hot dogs, place on plate. When the oven beeps, add buns and re-start the oven.
French Fries	4-5 oz 6-7 oz	<ul style="list-style-type: none"> Place 2 paper towels on plate and arrange french fries on towels, do not overlap. Blot with additional paper towel after removal from oven.
Frozen Sandwich	1 EA 2 EA	<ul style="list-style-type: none"> Place frozen sandwich in susceptor "sleeve" (which is in package) and put on plate.

Setting Cooking Times & Power Levels

Your microwave allows you to set up to three different stages of cooking, each with its own time length and power level. The power level lets you control the heating intensity from Warm (1) to High (0).

One-stage Cooking

For simple one-stage cooking, you only need to set a cooking time. The power level is automatically set at High. If you want the power set at any other level, you must set it using the **Power Level** button.

- 1 Use the number buttons to set a cooking time. You can set a time from one second to 99 minutes, 99 seconds. To set a time over one minute, enter the seconds too.

For example, to set 20 minutes, enter 2, 0, 0, 0.

- 2 If you want to set the power level to something other than High, press the **Power Level** button, then use the number buttons to enter a power level.

Power Levels:

1 = Warm	6 = Simmer
2 = Low	7 = Medium High
3 = Defrost	8 = Reheat
4 = Medium Low	9 = Sauté
5 = Medium	0 = High

The display shows "PRESS START OR ENTER NEXT STAGE COOKING TIME".

PRESS START OR ENTER NEXT
STAGE COOKING TIME

- 3 Press the **Start** button to begin cooking. If you want to change the power level, press **Pause/Cancel** before you press **Start**, and reenter all of the instructions.

Some recipes require different stages of cooking at different temperatures. You can set multiple stages of cooking with your microwave.

Multi-stage Cooking

- 1 Follow steps 1 and 2 in the "One-Stage Cooking" section on the previous page. The display shows "PRESS START OR ENTER NEXT STAGE COOKING TIME".

PRESS START OR ENTER NEXT
STAGE COOKING TIME

*When entering more than one cooking stage, the **Power Level** button must be pressed before the second cooking stage can be entered.*

*To set the power level at High for a stage of cooking, press the **Power Level** button twice.*

- 2 Use the **Number** buttons to set a second cooking time.
- 3 Press the **Power Level** button, then use the number buttons to set the power level of the second stage of cooking. The display shows the power level you have set and then "PRESS START OR ENTER NEXT STAGE COOKING TIME."

PRESS START OR ENTER NEXT
STAGE COOKING TIME

- 4 Press **Start** to begin cooking, or repeat steps 2 and 3 to set a cooking time and power level for a third stage of cooking. When finished, press **Start**.

Programming Instructions for AMC5143AA*

Model AMC5143AA*

Setting the Word Prompting Speed

- 1 Press the **My Choice** button and then press **7**. The display shows "WORD PROMPTING SPEED".



WORD PROMPTING SPEED

- 2 Press the **My Choice** button to select the appropriate scroll speed



LEVEL 1

- 3 Press the **Start** button. The display returns to the time of day.

Using the More/Less Buttons

The More/Less buttons allow you to adjust pre-set cooking times. They only work in the **Sensor Reheat**, **Sensor Cooking**, **Instant Cook**, **Handy Helper**, **Kids Meals**, **Snack Bar** or **Time Cook** modes. Use the More/Less button only after you have already begun cooking with one of these procedures.

- 1 To ADD more time to an automatic cooking procedure: Press the **More(9)** button.
- 2 To REDUCE the time of an automatic cooking procedure: Press the **Less(1)** button.

*If you wish to increase/decrease in **Time Cook** mode by 10 seconds, press the More(9) or Less(1) button.*

Adjusting the Volume

The Sound function on the microwave allows you to adjust the volume of the microwave's chime sound. The sound is initially set to its high setting. To change the volume,

- 1 Press the **My Choice** button and then press **3**. The display shows "SOUND VOLUME CONTROLS".



SOUND VOLUME CONTROLS

- 2 Press the **My Choice** button repeatedly to select volume.
- 3 Press **Start**: The display returns to the time of day.

Using the Kitchen Timer

- 1 Use the **Number** buttons to set the length of time you want the timer to run.
- 2 Press the **Kitchen Timer** button.
- 3 The display counts down and beeps when the time has elapsed.

Setting the Child Protection Lock

You can lock your microwave oven so it can't be used by unsupervised children.

- 1 Press the **My Choice** Button and then press the **5** button. The display shows "CHILD LOCK ON/OFF".



CHILD LOCK ON/OFF

- 2 Press the **My Choice** button once to select the ON. Press again to select OFF.



ON

- 3 Press the **Start** button. The display returns to the time of day. *At this point, the microwave oven cannot be used until it is unlocked. To unlock it, repeat steps 1-3 above.*

Setting the Remind End Signal

The Remind End Signal can be set On or Off.

- 1 Press the **My Choice** button and then press **4**. The display shows "REMIND END SIGNAL ON/OFF".



REMIND END SIGNAL ON/OFF

- 2 Press the **My Choice** button to select ON.



ON

- 3 Press the **Start** button. The display returns to the time of day. To turn Remind End Signal off, repeat steps 1-3 above.

Demonstration Mode

You can use the Demonstration Mode to see how your microwave oven operates without the oven heating.

- 1 Press the **My Choice** button and then Press **9**. The display shows " DEMO MODE ON/OFF"



DEMO MODE ON/OFF

- 2 Press the **My Choice** button once to select ON. Press again to select OFF.



ON

- 3 Press the **Start** button. The display shows "DEMO". To turn demo mode off, repeat steps 1-3 above.

Programming Instructions for MMC5193AA*

Model MMC5193AA*

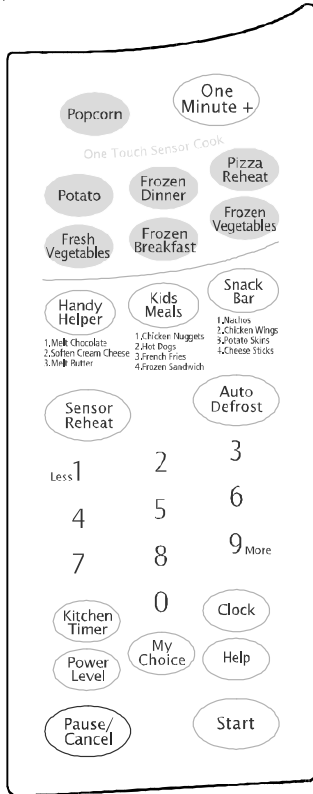

1. One Minute +

Press once for every minute of cooking at High power.

2. Sensor Cook Buttons

Sensor settings to cook popular foods.

3. Handy Helper, Kids Meals, Snack Bar

Selects type of dish to be reheated.

4. Sensor Reheat

5. Auto Defrost

Sets weight of food to be defrosted.

6. Number Buttons

Set cooking times or amounts and power levels other than high.

7. More/Less

Increase or decrease cooking time.

8. Kitchen Timer

Sets kitchen or convenience timer.

9. Power Level

Press this pad to set a power level other than high.

10. Pause/Cancel

Press to pause oven or correct a mistake.

11. My Choice

Press to set non-cooking feature.

12. Clock

Sets current time

13. Help

Press to see help information about the feature you are using.

14. Start

Press to start cooking.

Turning on the Power and Selecting a Display Language

The first time you plug the power cord into an outlet, or after there has been an interruption in power, the display shows after four seconds "ENJOY YOUR COOKING --- PRESS MY CHOICE FOR PERSONAL OPTIONS"

- 1 Press **My Choice** immediately after plugging in your microwave. The display will show "PRESS 1-9 TO SELECT VARIOUS OPTIONS".
- 2 Press the **1** button.
- 3 Press **My Choice**
- 4 Press **My Choice** repeatedly to select the language you wish to use:
 - ENGLISH
 - FRENCH
 - SPANISH
- 5 Press the **Start** button.

Using the My Choice feature

Your new microwave oven can be customized to suit your personal tastes. Simply press **My Choice** to set these options. For your convenience, all the options are summarized in the following table:

My Choice options	Description	Operation
Display Weight	Weight options are pounds or kilograms.	Press My Choice , 2 and select by repeatedly pressing My Choice . To set, press Start .
Adjusting the Volume	Volume options include Off, Low, Medium, High and Melody 1-5.	Press My Choice , 3 and select by repeatedly pressing My Choice . To set, press Start .
Remind End Signal	The Remind End Signal can be turned On and Off.	Press My Choice , 4 and select by repeatedly pressing My Choice . To set, press Start .
Child Protection Lock	This feature prevents use by unsupervised children.	Press My Choice , 5 and select by pressing My Choice . To set, press Start .
Clock 12HR/24HR	The clock can display either 12HR or 24HR time modes.	Press My Choice , 6 and select by repeatedly pressing My Choice . To set, press Start .
Word Prompting Speed	There are five speeds, from Level 1 (slowest) to Level 5 (fastest). Default is Level 3.	Press My Choice , 7 and select by repeatedly pressing My Choice . To set, press Start .
Daylight Savings Time Adjustment	The time can be advanced one hour for DST without resetting the Clock.	Press My Choice , 8 and select by repeatedly pressing My Choice . To set, press Start .
Demonstration Mode	The Demo Mode can be turned On and Off.	Press My Choice , 9 and select by repeatedly pressing My Choice . To set, press Start .

If there is a power interruption, you will need to reset these options.

Programming Instructions for MMC5193AA*

Model MMC5193AA*

Selecting the Display Weight

You can choose between pounds(LBS) and kilograms(KG).

- 1 Press **My Choice** button and then press the **2** button. The display shows "LBS OR KG"
- 2 Press the **My Choice** button repeatedly to select the weight measurements you wish to use.
- 3 Press the **Start** button.

Setting the Clock 12HR/24HR

The time can be displayed in either 24-hour or 12-hour format.

- 1 Press the **My Choice** button and then **6**. The display shows "CLOCK 12HR/24HR OPTION".
- 2 Press the **My Choice** button repeatedly to select either 12HR or 24HR.
- 3 Press the **Start** button

Setting the Clock

- 1 Press the **Clock** button.
- 2 Use the number buttons to enter the current time. You must press at least three numbers to set the clock. For example, if the current time is 5:00, enter 5,0,0.
- 3 Press **Clock** again. A colon will appear, indicating that the time is set.

If there is a power interruption, you will need to reset the clock.

*You can check the current time while cooking is in progress by pressing the **Clock** button.*

Setting the Daylight Saving Time adjustment

- 1 Press the **My Choice** button and then **8**. The Display shows "DAYLIGHT SAVING TIME ON/OFF".
- 2 Press the **My Choice** button to select ON. Press again to select OFF.
- 3 Press the **Start** button. Time of day will advance one hour. If OFF is selected, time will go back one hour.

If the clock is set for standard time, this function allows convenient time changes without needing to reset the clock. Daylight Saving Time begins for most of the United States at 2 a.m. on the first Sunday of April, and reverts to Standard time at 2 a.m. on the last Sunday of October.

Using the Pause/Cancel Button

The **Pause/Cancel** button allows you to clear instructions you have entered. It also allows you to pause the oven's cooking cycle, so that you can check the food.

- To pause the oven during cooking : press **Pause/Cancel** once. To restart, press **Start**.
- To stop cooking, erase instructions, and return the oven display to the time of day: press **Pause/Cancel** twice.
- To clear instructions you have just entered: press **Pause/Cancel** once, then re-enter the instructions.
- To cancel a timer setting: press **Pause/Cancel** once.

Using the Help Button

Your microwave offers helpful instructions for many procedures.

- 1 When you need feature information and helpful hints, press the **Help** button and then press the button that you want to get information on. Help information is available in 3 languages (English, French and Spanish).

Using the Sensor Cook Buttons

By actually sensing the steam that escapes as food heats, this feature automatically adjusts the oven's heating time for various types and amounts of precooked food. All food should be precooked and at refrigerator temperature.

- 1 Press the **Sensor Cook** button corresponding to the food you are cooking (**Popcorn**, for example). The display shows "POPCORN" and your microwave oven will begin cooking automatically.

When cooking popcorn, wait at least five minutes between each bag to avoid overheating the glass tray. If you want to adjust the cooking time, you can use the **More/Less** buttons. See page 14 for more information. If you want to check the current time while cooking is in progress, press the **Clock** button.

Programming Instructions for MMC5193AA*

Model MMC5193AA*

Using the One Minute + Button

This button offers a convenient way to heat food in one minute increments at the High power level.

- 1 Press the **One Minute+** button once for each minute you wish to cook the food. For example, press it twice for two minutes. The time will display, and the oven starts automatically.

*Add minutes to a program in progress by pressing the **One Minute+** button for each minute you want to add.*

Sensor Reheat

Heating leftovers and precooked foods is easy with your new microwave. By actually sensing the steam that escapes as food heats, this feature automatically adjusts the oven's heating time for various types and amounts of precooked food. All food should be precooked and at refrigerator temperature. To use sensor reheating:

- 1 Press **Sensor Reheat**. The display will show "REHEAT" and the oven will start automatically.

Defrosting Automatically

To thaw frozen food, set the weight of the food and the microwave automatically sets the defrosting time, power level and standing time.

- 1 Press the **Auto Defrost** button. The display shows "0.5 LB." (0.2Kg if you have set your oven for metric measure).
- 2 To set the weight of your food, press the **Auto Defrost** button repeatedly. This increases the weight by 0.5 lb increments, up to 6.0 lbs. You can also use the number buttons to enter the weight of the food directly. The oven calculates the defrosting time and starts automatically. Twice during defrosting, the oven will beep and the display will read "TURN THE FOOD OVER."
- 3 Press the **Pause/Cancel** button, open the oven door, and turn the food over.
- 4 Press the **Start** button to resume defrosting.

Using the Handy Helper Button

1. Press the **Handy Helper** button corresponding to the food you are cooking. The display shows "Melt Chocolate". Press the **Handy Helper** button repeatedly to select the item you want. (Refer to the **Handy Helper Chart** below)
2. Press the **Number** button to select the serving size you want. You can press the **1** or **2** button to select the serving size. Only the **1** button (serving) is available for Soften Cream Cheese and Melt Chocolate items. (Refer to the **Handy Helper Chart** below for the serving)
3. Press the **Start** button to begin cooking.

Handy Helper Chart

Item	Weight	Remarks
Melt Chocolate	2 squares or 1 cup chips	<ul style="list-style-type: none">• Place chocolate chips or square in a microwave-safe dish.• Stir well at half time when the oven beeps, and re-start the oven.• Unless stirred, the chocolate keeps its shape even when heating time is over.
Soften Cream Cheese	1 package (8 oz.)	<ul style="list-style-type: none">• Unwrap cream cheese and place on microwave-safe dish.• Let stand 1-2 min.
Melt Butter	1 stick (1/4 lb.) 2 sticks (1/2 lb.)	<ul style="list-style-type: none">• Remove wrapping and cut butter in half vertically.• Place butter in dish, cover with wax paper.• Stir well after finishing and let stand 1-2 min.

Using the Kids Meals Button

1. Press the **Kids Meals** button corresponding to the food you are cooking. The display shows "Chicken Nuggets". Press the **Kids Meals** button repeatedly to select the item you want. (Refer to the **Kids Meals Chart** below)
2. Press the **Number** button to select the serving size you want. You can press the **1** or **2** button to select the serving size. (Refer to the **Kids Meals Chart** below for the serving.)
3. Press the **Start** button to begin cooking.

Kids Meals Chart

Item	Weight	Remarks
Chicken Nuggets	4-5 oz 6-7 oz	<ul style="list-style-type: none">• Put a paper towel on top of plate and arrange nuggets in spoke fashion on paper towel.• Do not cover. Let stand 1 min.
Hot Dogs	2 EA 4 EA	<ul style="list-style-type: none">• Prick hot dogs, place on plate. When the oven beeps, add buns and re-start the oven.
French Fries	4-5 oz 6-7 oz	<ul style="list-style-type: none">• Place 2 paper towels on plate and arrange french fries on towels, do not overlap.• Blot with additional paper towel after removal from oven.
Frozen Sandwich	1 EA 2 EA	<ul style="list-style-type: none">• Place frozen sandwich in susceptor "sleeve" (which is in package) and put on plate.

Programming Instructions for MMC5193AA*

Model MMC5193AA*

Using the Snack Bar Button

1. Press the **Snack Bar** button corresponding to the food you are cooking. The display shows "Nachos"
Press the **Snack Bar** button repeated to select the item you want. (Refer to the **Snack Bar Chart** below)
2. Press the **Number** button to select the serving size you want. You can press the **1** or **2** button to select the serving size. Only the **1** button (serving) is available for Nachos. (Refer to the **Snack Bar Chart** below for the serving)
3. Press the **Start** button to begin cooking.

Snack Bar Chart

Item	Weight	Remarks
Nachos	1 serving	<ul style="list-style-type: none">• Place tortilla chips on plate without overlapping.• Sprinkle evenly with cheese.• Contents :<ul style="list-style-type: none">- 2 cups tortilla chips- 1/3 cup grated cheese
Chicken Wings	5-6 oz 7-8 oz	<ul style="list-style-type: none">• Use pre-cooked, refrigerated chicken wings.• Place chicken wings around plate in spoke fashion and cover with wax paper.
Potato Skins	1 cooked potato 2 cooked potatoes	<ul style="list-style-type: none">• Cut cooked potato into 4 even wedges. Scoop or cut out potato flesh, leaving about 1/4" of skin.• Place skins in spoke fashion around plate.• Sprinkle with bacon, onions and cheese. Do not cover.
Cheese Sticks	5-6 pcs 7-10 pcs	<ul style="list-style-type: none">• Place cheese sticks on plate in spoke fashion.• Do not cover.

Setting Cooking Times & Power Levels

Your microwave allows you to set up to three different stages of cooking, each with its own time length and power level. The power level lets you control the heating intensity from Warm (1) to High (0).

One-stage Cooking

For simple one-stage cooking, you only need to set a cooking time. The power level is automatically set at High. If you want the power set at any other level, you must set it using the **Power Level** button.

- 1 Use the number buttons to set a cooking time. You can set a time from one second to 99 minutes, 99 seconds. To set a time over one minute, enter the seconds too.

For example, to set 20 minutes, enter 2, 0, 0, 0.

- 2 If you want to set the power level to something other than High, press the **Power Level** button, then use the number buttons to enter a power level.

Power Levels:

- | | |
|----------------|-----------------|
| 1 = Warm | 6 = Simmer |
| 2 = Low | 7 = Medium High |
| 3 = Defrost | 8 = Reheat |
| 4 = Medium Low | 9 = Sauté |
| 5 = Medium | 0 = High |

The display shows "PRESS START OR ENTER NEXT STAGE COOKING TIME".

- 3 Press the **Start** button to begin cooking. If you want to change the power level, press **Pause/Cancel** before you press **Start**, and reenter all of the instructions.

Setting Cooking Times, continued

Some recipes require different stages of cooking at different temperatures. You can set multiple stages of cooking with your microwave.

Multi-stage Cooking

- 1 Follow steps 1 and 2 in the "One-Stage Cooking" section on the previous page. The display shows "PRESS START OR ENTER NEXT STAGE COOKING TIME".

*When entering more than one cooking stage, the **Power Level** button must be pressed before the second cooking stage can be entered.*

*To set the power level at High for a stage of cooking, press the **Power Level** button twice.*

- 2 Use the **Number** buttons to set a second cooking time.

- 3 Press the **Power Level** button, then use the number buttons to set the power level of the second stage of cooking. The display shows the power level you have set and then "PRESS START OR ENTER NEXT STAGE COOKING TIME".

- 4 Press **Start** to begin cooking, or repeat steps 2 and 3 to set a cooking time and power level for a third stage of cooking. When finished, press **Start**.

Using the More/Less Buttons

The More/Less buttons allow you to adjust pre-set cooking times. They only work in the **Sensor Reheat, Sensor Cooking, Instant Cook, Handy Helper, Kids Meals, Snack Bar or Time Cook** modes. Use the More/Less button only after you have already begun cooking with one of these procedures.

- 1 To ADD more time to an automatic cooking procedure: Press the **More(9)** button.
- 2 To REDUCE the time of an automatic cooking procedure: Press the **Less(1)** button.

*If you wish to increase/decrease in **Time Cook** mode by 10 seconds, press the **More(9)** or **Less(1)** button.*

Programming Instructions for MMC5193AA*

Model MMC5193AA*

Adjusting the Volume

The Sound function on the microwave allows you to adjust the volume of the microwave's chime sound. The sound is initially set to its high setting. To change the volume,

- 1 Press the **My Choice** button and then press **3**. The display shows "SOUND VOLUME CONTROLS".
- 2 Press the **My Choice** button repeatedly to select volume.
- 3 Press **Start**: The display returns to the time of day.

Using the Kitchen Timer

- 1 Use the **Number** buttons to set the length of time you want the timer to run.
- 2 Press the **Kitchen Timer** button.
- 3 The display counts down and beeps when the time has elapsed.

Setting the Child Protection Lock

You can lock your microwave oven so it can't be used by unsupervised children.

- 1 Press the **My Choice** Button and then Press the **5** button. The display shows "CHILD LOCK ON/OFF".
- 2 Press the **My Choice** button once to select the ON. Press again to select OFF.
- 3 Press the **Start** button. The display returns to the time of day.

At this point, the microwave oven cannot be used until it is unlocked. To unlock it, repeat steps 1-3 above.

Demonstration Mode

You can use the Demonstration Mode to see how your microwave oven operates without the oven heating.

- 1 Press the **My Choice** button and then press **9**. The display shows "DEMO MODE ON/OFF".
- 2 Press the **My Choice** button once to select ON. Press again to select OFF.
- 3 Press the **Start** button. The display shows "DEMO". To turn demo mode off, repeat steps 1-3 above.

Setting the Remind End Signal

The Remind End Signal can be set On or Off.

- 1 Press the **My Choice** button and then press **4**. The display shows "REMIND END SIGNAL ON/OFF".
- 2 Press the **My Choice** button to select ON.
- 3 Press the **Start** button. The display returns to the time of day. To turn Remind End Signal off, repeat steps 1-3 above.

Setting the Word Prompting Speed

- 1 Press the **My Choice** button and then press **7**. The display shows "WORD PROMPTING SPEED".
- 2 Press the **My Choice** button to select the appropriate scroll speed.
- 3 Press the **Start** button. The display returns to the time of day.

Care and Cleaning

All Models

Care and Cleaning

Follow these instructions to clean and care for your oven.

- Keep the inside of the oven clean. Food particles and spilled liquids can stick to the oven walls, causing the oven to work less efficiently.
- Wipe up spills immediately. Use a damp cloth and mild soap. Do not use harsh detergents or abrasives.
- To help loosen baked on food particles or liquids, heat two cups of water (add the juice of one lemon if you desire to keep the oven fresh) in a four-cup measuring glass at High power for five minutes or until boiling. Let stand in the oven for one or two minutes.
- Remove the glass tray from the oven when cleaning the oven or tray. To prevent the tray from breaking, handle it carefully and do not put it in water immediately after cooking. Wash the tray carefully in warm sudsy water or in the dishwasher.
- Clean the outside surface of the oven with soap and a damp cloth. Dry with a soft cloth. To prevent damage to the operating parts of the oven, don't let water seep into the openings.
- Wash the door window with very mild soap and water. Be sure to use a soft cloth to avoid scratching.
- If steam accumulates inside or outside the oven door, wipe with a soft cloth. Steam can accumulate when operating the oven in high humidity and in no way indicates microwave leakage.
- Never operate the oven without food in it; this can damage the magnetron tube or glass tray. You may wish to leave a cup of water in the oven when it is not in use to prevent damage if the oven is accidentally turned on.