

MAYTAG

**Maytag
Performa**

**Dryer
Service Manual**

16023116

SAFETY PRECAUTIONS

THIS MANUAL, AS WELL AS THE INFORMATION CONTAINED IN IT, IS TO BE USED ONLY BY A MAYTAG AUTHORIZED SERVICE TECHNICIAN FAMILIAR WITH AND KNOWLEDGEABLE OF PROPER SAFETY AND SERVICING PROCEDURES AND POSSESSING HIGH QUALITY TESTING EQUIPMENT ASSOCIATED WITH MICROWAVE, GAS, AND ELECTRICAL APPLIANCE REPAIR.

ALL INDIVIDUALS WHO ATTEMPT REPAIRS BY IMPROPER MEANS OR ADJUSTMENTS, SUBJECT THEMSELVES AND OTHERS TO THE RISK OF SERIOUS OR FATAL INJURY.

USE ONLY GENUINE MAYTAG APPROVED FACTORY REPLACEMENT COMPONENTS.

INTRODUCTION

The information presented in this manual applies to the 27" negative pressure dryer, both electric and gas models.

No distinction has been made between the gas and electric models as long as the components and/or service procedures are common to both. However, anything of a unique nature between these models has been detailed and labeled as such in the manual.

Since the dryer was designed to utilize the modular concept of assembly, the same approach was taken in the preparation of this manual whenever possible.

The manual is printed in a loose format and is divided into sections relating to a general group of components and/or service procedures. Each section is further subdivided to describe a particular component or service procedure.

The subdividing of the subject matter plus the loose leaf form will facilitate the updating of the manual as new or revised components are added or new models are introduced.

Each page of the manual will be identified in the lower right-hand corner, and as new or revised pages are published, the manual can easily be updated by following the filing instructions on the cover letter of the supplement.

This service manual is a valuable tool and care should be taken to keep it up to date by prompt and proper filing of subsequent pages as they are used.

MODELS COVERED IN THIS MANUAL:

PYE2000AY*
PYG2000AW*
HYE3657*
HYE3658*
PYET344*
HYE3460*
PYET444*
DLE/DLG231
PYE/PYG2300
PYE/PYG3200
PYE/PYG3300
PYE/PYG4500
PYE/PYG4557
PYE/PYG4558

Contents

SECTION 1. INSTALLATION	1-1
INSTALLATION REQUIREMENT	1-1
Dryer Location (All Models)	1-1
Dryer Location (Gas Models Only)	1-1
Gas Connection Requirements	1-1
Electrical Requirements (Gas Models)	1-2
Electrical Requirements (Electric Models)	1-2
Exhaust Requirements (All Models)	1-3
Length of Vent	1-4
Vent Hood	1-4
INSTALLATION INSTRUCTIONS	1-4
Installing the Dryer	1-4
Connecting the Gas	1-5
Typical Electrical Connections (Electric Model)	1-7
Connecting the Electric Model Dryer	1-7
Exhausting the Dryer	1-8
Leveling the Dryer	1-10
SECTION 2. OPERATION	2-1
DRYER OPERATION OVERVIEW	2-1
OPERATING INSTRUCTIONS	2-1
Opening the Door	2-1
Lint Screen	2-2
Controls	2-2
Cycle Selector	2-2
Cycles	2-2
Special Options	2-3
OPERATION TEST	2-3
SECTION 3. CABINET ASSEMBLY COMPONENTS	3-1
CABINET AND BASE ASSEMBLY	3-1
TOP ASSEMBLY	3-1
FRONT PANEL ASSEMBLY	3-3
COLLECTOR DUCT ASSEMBLY	3-4
DOOR ASSEMBLY	3-4
DOOR SEAL	3-6
SECTION 4. CYLINDER ASSEMBLY AND RELATED PARTS	4-1
CYLINDER ASSEMBLY	4-1
Cylinder Belt	4-2
CYLINDER SUPPORT ROLLERS AND GLIDE	4-3
REAR ROLLER SUPPORT ASSEMBLIES	4-3
GLIDE ASSEMBLY	4-4
FRONT AND REAR SEALS	4-5

SECTION 5. BLOWER AND DRIVE MODULE	5-1
BLOWER ASSEMBLY	5-2
COVER ASSEMBLY	5-2
BLOWER WHEEL	5-3
HOUSING ASSEMBLY	5-3
IDLER ASSEMBLY	5-4
MOTOR AND PULLEY ASSEMBLY	5-4
SECTION 6. HEAT SOURCE AND RELATED PARTS	6-1
HEATER ASSEMBLY	6-2
CONTROL AND BURNER ASSEMBLY	6-3
SILICON CARBIDE IGNITION SYSTEM	6-4
Gas Control Valve	6-5
Holding Coil	6-5
Booster Coil	6-5
Second Coil	6-5
Flame Sensor	6-5
Silicon Carbide Igniter	6-6
CIRCUIT OPERATION	6-6
Normal Ignition - Start	6-6
Normal Ignition	6-6
SAFETY FEATURES	6-7
Power Interruption	6-7
Ignition Failure	6-7
Flame Failure	6-8
PART REMOVAL AND REPLACEMENT	6-8
BULKHEAD ASSEMBLY	6-9
Inlet Duct (Gas Model) or Heater Housing (Electric)	6-10
High Limit Thermostat	6-10
Thermal Fuse	6-10
Cylinder Light Lens	6-10
Terminal Block (Electric Model)	6-10
Rear Seal	6-10
Rear Support Rollers	6-10
BULKHEAD ASSEMBLY REMOVAL	6-10
SECTION 7. BACKGUARD ASSEMBLY	7-1
SECTION 8. ELECTRICAL COMPONENTS AND TESTING	8-1
TIMER	8-1
Resistor (Electric Models Only)	8-1
Timer Access and/or Removal	8-1
Timer Sequence Chart	8-1
Contact Functions	8-1
WRINKLE RELEASE SWITCH	8-2
TEMPERATURE SELECTOR SWITCH	8-2

DOOR SWITCH	8-7
SILICON CARBIDE IGNITION SYSTEM	8-7
No Igniter Glow	8-8
Igniter Glows - No Gas Ignition	8-8
Gas Ignites - Flame Goes Out	8-8
HEATER ELEMENT ASSEMBLY	8-8
THERMOSTATS	8-8
Control Thermostat	8-9
High Limit Thermostat	8-9
Inlet Air Control Thermostat (Gas Models Only)	8-9
THERMAL FUSE	8-10
MOTOR	8-11
Overload Protector Switch	8-11
Motor Switch	8-12
SECTION 9. WIRING AND SCHEMATICS	9-1
DLE231*	9-1
DLG231*	9-3
PYE2300*, HYE2460*, PYET244*	9-5
PYG2300*	9-7
PYE3200*/3300*	9-9
PYG3200*/3300*	9-11
PYE4500*/4557*/4558*	9-13
PYG4500*/4557*/4558*	9-15
HYE3657*, HYE3658*, PYET344*	9-17
HYE3460*	9-19
PYET444*	9-21

SAFETY NOTES

This manual is designed and intended for the experienced service technician; one who possesses a level of mechanical and electrical knowledge commonly recognized as acceptable in the appliance service field and who is familiar with the construction and operation of Maytag serviced products. Maytag and/or the product manufacturer assume no liability for the use or interpretation of this service manual by any other persons.

To reduce the possibility of personal injury and/or property damage, it is necessary to observe certain safety precautions during the servicing of electrical or gas model dryers. The following are some, but not necessarily all, of the precautions which should be followed:

1. Disconnect electrical supply before servicing machine.
2. If electricity is required for a test; first, make any connections or adjustments required for the test; second, reconnect the electrical supply; third, perform the test. If additional service is required, disconnect the electrical supply before continuing.
3. On base model dryers, do not disturb a gas carrying component or connection until the gas supply to the dryer is shut off. Following the repair, make certain all gas connections are properly secured by testing for gas leaks with a bubble or soap solution.

WARNING: DO NOT use a flame to test for gas leaks.

4. Never attempt to bypass or otherwise interfere with the proper operation of any device engineered into the product.
5. Ground wires, usually green in color, should never be used as current carrying conductors.
6. Use only authorized factory replacement parts.
7. Prior to reconnecting the electrical supply to the dryer after servicing, ensure that:
 - All electrical connections within the dryer are correctly and securely attached.
 - All electrical leads are properly protected from sharp edges, high temperature components and moving parts.

- Any uninsulated current carrying metal parts have adequate spacing from all non-current carrying metal parts.
 - All electrical grounds, both internal and external to the dryer, are re-established and securely connected.
8. Following the servicing and prior to operating the dryer, properly and securely reassemble all panels.

SPECIFICATIONS

DIMENSIONS

Height
Width
Depth
Door Clearance Required

ALL MODELS

44"
27"
27"
53 1/2"

ELECTRICAL

Power Supply
Motor
Heating Element
Circuit
Fuse Size

ELECTRIC MODEL

240V
420W
4750W
No. 10 AWG Copper
30A

GAS MODEL

120V
420W
No. 12 AWG Copper
15A

GAS REQUIREMENTS

Rated Input
Type
Inlet Size
Ignition Type

GAS MODEL

18,000 BTU/Hr.
Natural
3/8" - 18 N.S.
Intermittent

MISCELLANEOUS

Air Flow
Cylinder Rotation
Cylinder Volume

ALL MODELS

175 C.F.M.
49 R.P.M.
7 C.F.

COMPONENT FINISH

Top Assembly
Cabinet Assembly
Front Panel
Cylinder Assembly

ALL MODELS

Enameled Steel
Enameled Steel
Enameled Steel
Primered Steel

SPECIAL TOOLS REQUIRED

No. T-10 Torx Bit
No. T-15 Torx Bit
No. T-20 Torx Bit

SECTION 1. INSTALLATION

IMPORTANT

For consumer safety and the proper operation of this dryer, it must be installed in accordance with all the installation requirements.

INSTALLATION REQUIREMENTS

Dryer Location (All Models)

The dryer is designed so that it can be installed in any location in the home. The dryer may even be installed in an unheated indoor location, such as a garage or utility building.

NOTE: With models having automatic dry cycles, the time dry setting should be used when room temperature drops below 50 degrees F, as the automatic cycle may not shut off.

DO NOT install the dryer on a carpeted floor.

DO NOT install the dryer where it may be exposed to the weather.

Dryer Location (Gas Models Only)

Gas model dryers must be installed to provide a minimum 19 inch clearance between the top of the dryer cabinet and any combustible construction. No clearances are required between the front, sides, back or the exhaust duct.

In ordinary installations, enough air will be available for proper operation of the gas burner. However, if the dryer is installed in a mobile home, a closet or tightly sealed room, provisions should be made for at least 18 inches of ventilation area. Air openings measuring a minimum 3 inch by 3 inch should be provided at the top and bottom of the closet door. Ordinarily, louvered doors will satisfy the ventilation requirements. Do not allow storage of any other materials to obstruct the ventilation openings.

NOTE: No other fuel burning appliance should be installed in the same room or closet as the dryer.

Flammable vapors such as those from spilled gasoline can be ignited by a clothes dryer, water heater or other non-sealed gas heating appliance. The National Fuel Code ANSI Z223.1-1980 requires that a gas appliance, when installed in a residential garage, be elevated so that the burner and the ignition device of the burner are a minimum of 18 inches above the floor. To satisfy this requirement, the dryer must be installed with the base at least 14 inches above the floor. In addition, the dryer must be located or protected to prevent damage from moving vehicles.

Gas Connection Requirements

The gas inlet connection at the rear of the gas model dryer is equipped with a 3/8 inch - 18 N.S. pipe thread. The supply line must be a 1/2 inch diameter, black rigid pipe (pipe diameter should be increased for runs longer than 20 feet). If

local codes permit, the dryer may be connected to the gas supply with approved semi-rigid metal tubing and listed connectors ***not over six (6) feet long***. An accessible shut off valve should be placed between the rigid pipe and the connector.

The installation must conform with local codes, or in the absence thereof, with the National Fuel Gas Code ANSI Z223 1-1980.

If the dryer is to be installed in a mobile home, a gas shut-off valve with a non-displaceable rotor must be installed in the gas supply piping. This valve must be located within the living space of the mobile home and within three (3) feet of the dryer.

Electrical Requirements (Gas Models)

The dryer is designed for 120 volt, 60 Hz AC current and will not operate on direct current or 50 Hz supplies.

It is recommended that a separate circuit be provided for the main entrance panel to the dryer receptacle by a qualified person in conformance with local codes. The circuit must be protected with a 15 amp time delay fuse or circuit breaker.

The dryer is equipped with a three-prong plug on the supply cord which must be plugged into a properly grounded three-hole wall receptacle.

NOTE: *The dryer, when installed, must be electrically grounded in accordance with local codes, or in the absence thereof, with the National Electric Code ANSI/NEPA No. 70-1981.*

Approved Grounding
Type Wall Receptacle

Three Prong
Grounding Plug
Power Supply Cord

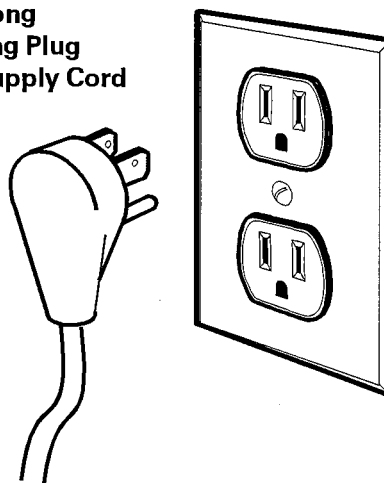

Electrical Requirements (Electric Models)

A separate circuit should be provided from the main service entrance panel (fuse box) to the dryer by a qualified person, in accordance with the National Electric Code and all local codes and ordinances. The circuit must be a three (3) or four (4) wire, 240 volt, 60 Hz, single phase, alternating current circuit. Each of the 120 volt line wires (line 1 and line 2) of this circuit must be protected by 30 amp time delay fuses or circuit breakers.

NOTE: *DO NOT fuse the neutral line or the ground line (if provided) of this circuit.*

All wires (including neutral and ground, if provided) of the dryer circuit must be No. 10 gauge copper wire for up to 40 foot lengths and No. 8 gauge copper wire for up to 60 foot lengths.

NOTE: *Never use a two wire cable with an uninsulated ground wire to connect the dryer.*

The ***National Electric Code*** requires all dryers to be installed with a means to

disconnect all ungrounded conductors wired to the dryer. Dryer installations using attachment plugs and receptacles (*see following figure*) satisfy this requirement. All other dryer installations must have a switch or circuit breaker located within sight of the dryer in order to satisfy this requirement.

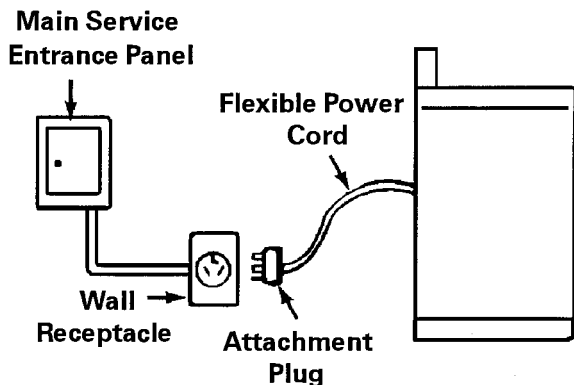

Dryers installed in mobile homes must be connected with either 4 conductor and 3 pole, 4-wire grounding type plugs, or by type AC metal-clad cable enclosed in flexible metal conduit (*see Typical Electrical Connections in the Installation Instructions*).

Where permitted by local codes, a flexible power cord may be connected to the dryer. A receptacle should be installed in the separate circuit connected to the main service entrance panel for this type of installation (*see above figure*). Use only UL approved 10 gauge, 3 or 4 wire, flexible power cords. The attachment plug of the power cord and the receptacle to which it will be connected must have a minimum current rating of 30 amps and have matching configurations.

Exhaust Requirements (All Models)

All gas dryers must be vented outdoors.

Never exhaust into a chimney duct, gas vent, wall ceiling, attic, confined space or under a building.

Do not use vinyl, plastic, cloth or other nonmetallic duct to exhaust the dryer.

Multiple installations require individual exhaust systems.

Dryers installed in a mobile home must be vented outdoors.

Exhausting can be accomplished directly from the rear of the cabinet, downward through the cabinet base, or through the cabinet sides.

NOTE: The gas models cannot be vented through the left side of the cabinet because of the burner and housing assembly. Standard 4 inch diameter galvanized or aluminum duct should be used. Do not use any duct that may be susceptible to rust. To avoid catching lint, the crimped end of each section of duct should face away from the dryer (*see following figure*).

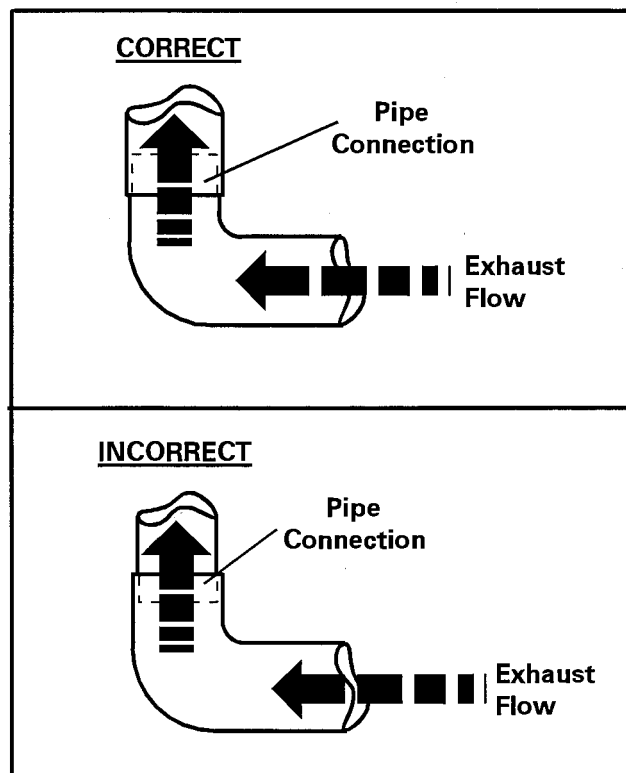

Length of Vent

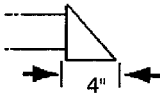
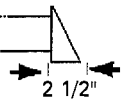
Number of 90° turns separated by at least 4 ft. of straight run	VENT HOOD TYPE	
	 4" OPENING	 2 1/2" OPENING
0	45 Feet	30 Feet
1	35 Feet	20 Feet
2	25 Feet	10 Feet

Although not recommended, flexible 4 inch diameter metal tubing may be used for exhausting the dryer. However, the convolutions create a greater restriction than solid ducting and serious blockage can result if the tubing is bent too sharply. If clearance to the wall is less than 8 inches, use a 4 inch sheet metal elbow at the rear of the dryer to avoid a sharp bend in the tubing. Do not use over 8 feet of flexible tubing between the elbow and the vent hood.

Vent Hood

The use of a vent hood on the outside is recommended (*see the following figure*). Vent hoods have a swing-out damper that opens when the dryer is in operation.

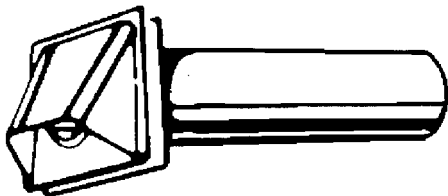

When the dryer stops, the damper automatically closes to prevent drafts and the entrance of insects and rodents. To avoid

restricting the outlet, maintain a minimum 8 inch clearance between the hood and the ground or other obstruction.

NOTE: *When installed in a mobile home, the vent hood must be securely fastened to the mobile home structure.*

SPECIAL REQUIREMENTS FOR MOBILE HOME INSTALLATIONS

When installed in a mobile home the dryer installation must conform to the manufactured home construction and safety standards, title 24 CFR, Part 32-80 (*formerly the Federal Standard for mobile home construction and safety, title 24 HUD, Part 280, 1975*).

INSTALLATION INSTRUCTIONS

Shipping Carton Removal: Dryers are shipped in a carton with glued flaps at the bottom and glued and banded flaps at the top. The carton can be removed by using a **short** bladed box knife and **CAREFULLY** cutting around the bottom of the carton along the dotted line. If no line is visible, make the cut approximately two (2) inches above the floor.

Lift the carton up and clear of the dryer.

Installing the Dryer

1. Remove the dryer from the shipping carton as previously explained.
2. Remove the tape and open the clothes door. Remove all literature from inside the dryer and instruct the consumer to save it for future reference.

3. Remove the crate base as follows:

Place your foot on the base, close to the leveling leg. Push down firmly with your foot while tilting the dryer away from you. Repeat the process with all four (4) leveling feet. Remove excess base by hand.

4. Set all leveling feet at the same height (*see the following figure*). A minimum of 1/2" clearance between the base of the machine and the floor is recommended. Adjust to match height of washer.

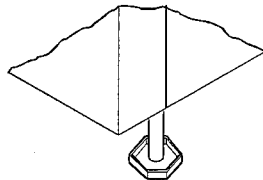

Leveling Foot

5. Place dryer in the location where it will be used. Check leveling by rocking dryer with hands on opposite corners. If it rocks, adjust as needed, to ensure that all four (4) feet are in firm contact with the floor (*see following figure*).

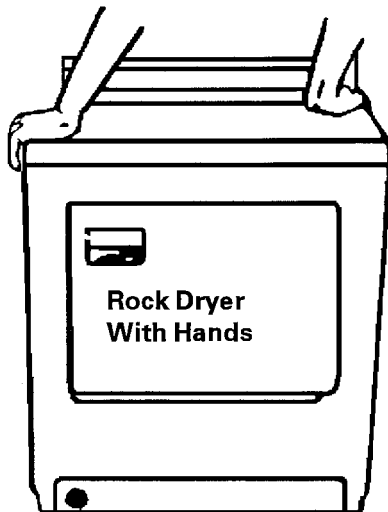

Gas Plug Button

Connecting the Gas

The dryer must be installed in accordance with the installation requirements.

1. Remove protective cap on gas inlet pipe connection if provided.
2. Using pipe seal compound, coat the threads of the gas inlet pipe connection protruding through the lower rear of the dryer (*see the following figure*).

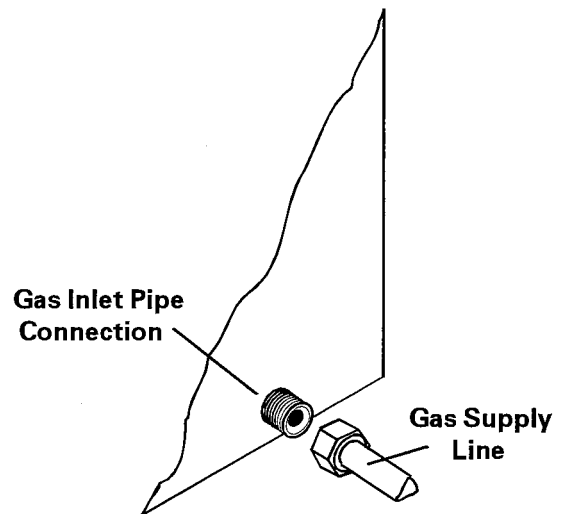

3. Attach the gas supply line to the gas inlet pipe connection.

NOTE: Care should be used when tightening the gas pipe connections to avoid distorting or straining the components. Moderate pressure is required to make a tight joint.

4. The dryer is shipped with the main gas shut off valve in the ON position. The gas shut off valve is located behind the plug button on the bottom of the dryer front panel.
5. Remove the plug button by inserting a screwdriver between the plug button and the outer plastic ring and lifting (*see the following figure*).

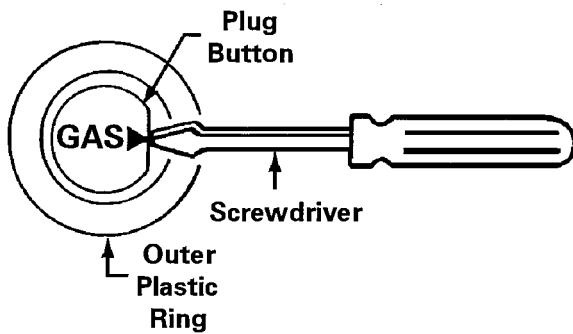

- When the plug button is removed, the main gas valve and the **ON/OFF** position on the outer ring are readily visible. Insert the screwdriver into the slot at the end of the valve stem and turn clockwise 1/4 turn to the **ON** position (*see the following figure*).

CAUTION

Do not use excessive force as damage to the valve may occur.

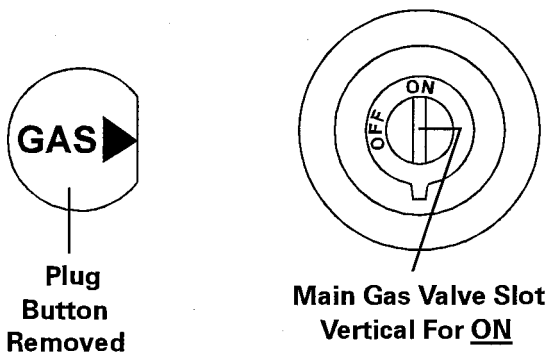

- Replace Plug button.
- Check all connections for leaks with soap and water.** If a leak is found, shut off gas, correct leak and retest.

DO NOT PURGE GAS LINE.

NOTE: *To gain access to the main gas valve, the front panel must be removed. This procedure is detailed under Bottom Exhausting.*

- Plug the dryer in. The dryer is equipped with an automatic ignition system and will purge itself and ignite when the **PUSH TO START** knob is depressed.

NOTE: *No gas adjustment is necessary at normal altitudes since the gas flow is controlled by a fixed size orifice for the main burner. For altitudes above 2000 feet, the input must be reduced by 4% for each additional 1000 feet above sea level. In some locations the gas utility has reduced the B.T.U. rate of the gas to provide this compensation. In other locations, the orifice must be changed. Consult your dealer or local gas utility for further information.*

- Turn off gas and unplug electric cord before continuing the installation.

NOTE: *Manifold pressure is preset to 3-1/2 inch W.C. and does not require adjustment. A 1/8 NPT plugged pressure tap is available in the gas valve body for testing. To check the pressure proceed as follows:*

1. Disconnect electric cord.
2. Raise the top of the dryer.
3. Remove the front panel by removing two screws inside the top corner of the front panel, disconnecting the door switch wires and hinging the front panel outward then lifting up.
4. Be sure the manual valve is off.
5. Remove the plug and install pressure tap.
6. Route pressure hose downward past

the front of the base between front panel hinge.

7. Reinstall front panel over pressure tap hose.
8. Connect the gauge, turn manual valve on, and check with dryer in operation.

Typical Electrical Connections (Electric Model)

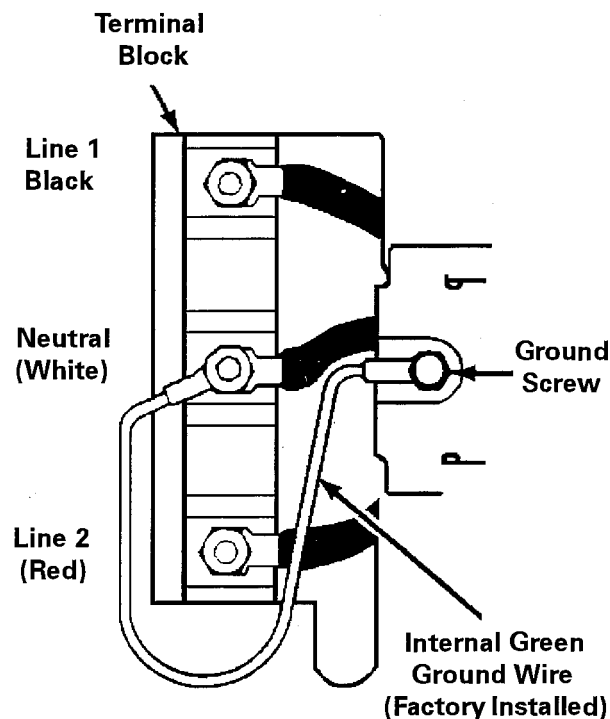

3-Wire System With Grounded Neutral: Connect power cord conductor to line 1, neutral and line 2 terminals of the terminal block as shown in the above figure.

NOTE: *Some 3-wire flat type power cords are not color coded. When using this type of power cord, connect the center conductor to neutral, connect one of the outside conductors to line 1 and connect the other outside conductor to line 2.*

3-Wire System With Separate Ground: Remove the internal green ground wire from the neutral terminal and ground screw. Connect the separate ground conductor to the ground screw. Then connect the power cord conductors to line 1, neutral and line 2 terminals (*shown in the figure on page 1-7*).

3-Wire System With Grounded Metal Clad Cable or Rigid Metal Conduit: Remove the internal ground wire from the neutral terminal and the ground screw. Connect the power cable conductors to line 1, neutral and line 2 terminals (*shown in the figure on page 1-7*).

NOTE: *An approved grounding type strain relief clamp or conduit connector must be used for this type of installation.*

4-Wire System: Remove internal green ground wire from the neutral terminal and the ground screw. Connect the power cord green grounding conductor to the ground screw. Connect the remaining power cord conductors to line 1, neutral and line 2 terminals as shown in the *figure on page 1-7*.

Connecting the Electric Model Dryer

NOTE: *The National Electric Code and all local codes and ordinances must be observed when connecting the dryer.*

1. To gain access to the terminal block, remove the supply cord cover plate which is attached to the upper left cabinet rear by two (2) screws.
2. Install a suitable strain relief clamp or conductor in the strain relief hole located adjacent to the terminal block (*see the following figure*).

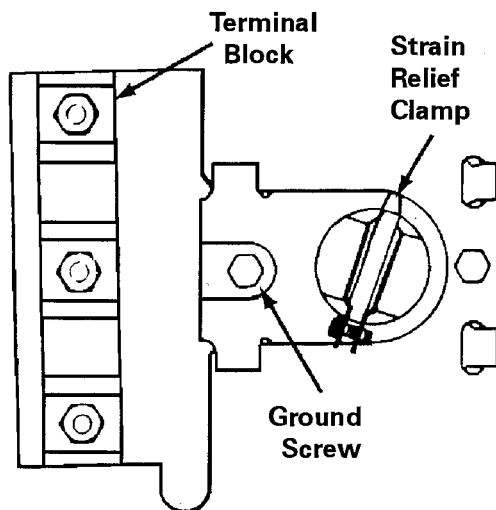

3. Route the power cord or cable conductors through the strain relief clamp.

CAUTION

The conductors should not extend into the dryer more than necessary to make the electrical connections.

4. Refer to the Typical Electrical Connections section previously listed and make the electrical connections as instructed.

NOTE: DO NOT remove the internal ground wire except where instructed and required by the local codes and ordinances of the area.

5. Check to be certain all conductors are correctly installed. Then securely tighten all terminal nuts and the ground screw.
6. Tighten the strain relief clamp.
7. Replace the supply cord cover plate.
8. Complete the dryer installation.

Exhausting the Dryer

NOTE: All gas and electric dryers MUST be vented outdoors.

All dryers are equipped at the factory for exhausting directly through the rear of the cabinet.

The dryer can also be bottom exhausted through the base, or side exhausted through either cabinet side.

NOTE: The gas dryer cannot be exhausted through the left side of the cabinet because of the location of the burner and housing assembly.

Bottom Exhausting

If space permits behind the dryer, a four (4) inch diameter elbow pointed downward may be used to pass the exhaust system through the floor. If this is not possible, the dryer may be exhausted through the dryer base.

When exhausting in this manner, the installation should be made according to the following:

1. Disconnect the unit from power source.
2. Raise the top of the dryer by pressing in with a putty knife on the top panel retaining clips as shown in the following figure.

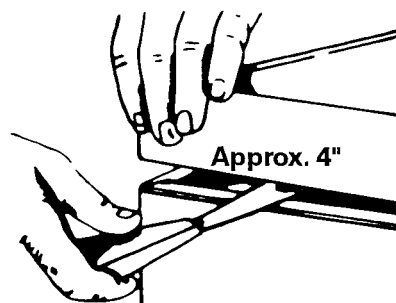

3. Remove the dryer front panel as follows:
 - a. Note the position of the front seal to the cylinder.
 - b. Remove the two (2) screws located inside the top corners of the front panel (*see the following figure*).

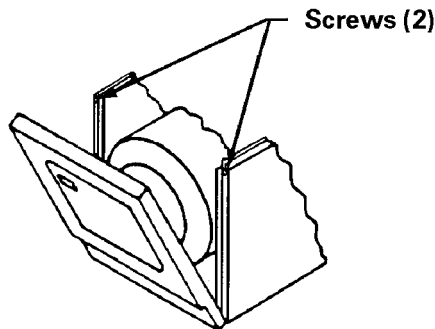

- c. Tilt front panel forward.
 - d. Disconnect door switch wires and lift front panel off.
4. Remove the cylinder as follows:

- a. Force the idler pulley to the right and remove cylinder belt from idler and motor pulley (*see the following figure*).
- b. Using the belt, lift rear of cylinder off support rollers and pull forward to remove.

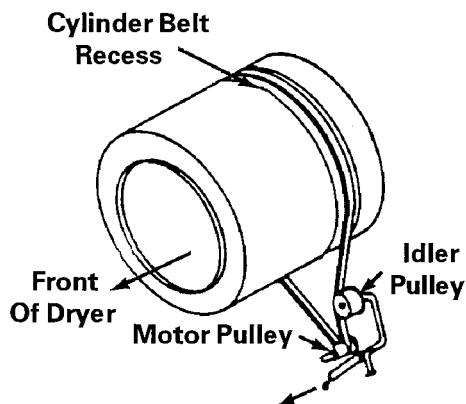

Belt Orientation

5. Remove duct tape and screw securing dryer vent pipe to the blower housing.
6. Remove the vent pipe and shorten to a suitable length (*see the following figure*).
7. Remove the knockout from the dryer base.
8. Place dryer in position and mark duct location on floor. Check floor joist location before sawing hole in floor.
9. Saw a 4-1/8 inch diameter hole in the floor and position dryer.
10. Secure the shortened vent pipe to the blower housing with the screw at the top and seal the connection with duct tape or silicone bathtub caulk (*see the following figure*).
11. Install a four (4) inch diameter, 90 degree elbow as shown in the following figure.

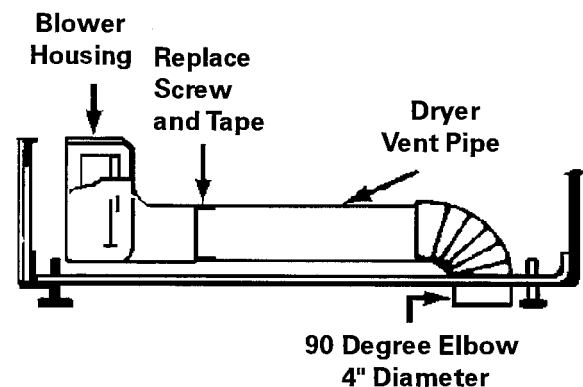

12. Seal the rear opening of the cabinet with the cover plate and screws provided in the literature pack.
13. Place the cylinder belt around the cylinder with the grooved side toward the cylinder.

14. Reinstall cylinder by pushing and turning until the support rollers snap in the cylinder grooves and the cylinder turns freely.
15. Position the cylinder belt with grooved side around motor pulley. Pull idler pulley to the right until the smooth side of the belt can be routed around the left side of the idler pulley (*see the following figure*).

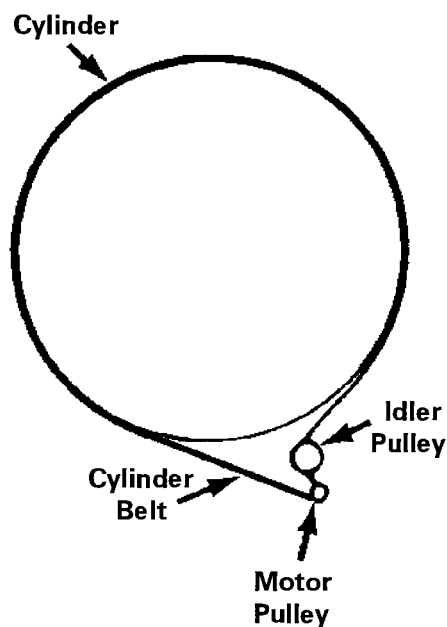

16. Manually rotate the cylinder counter clockwise to position the belt.
17. Replace the front panel and reconnect the door switch wires. Make sure the front seal is in the original position.
18. Complete the exhaust system to outdoors.

Side Exhausting

The following figure illustrates side exhaust venting pipe connections inside the dryer cabinet. When venting the dryer from the side, the cabinet knockout must be removed. The vent pipe must be shortened and used with a 4 inch diameter,

90 degree elbow as shown. Secure the shortened vent pipe to the blower housing with a screw at the top and seal the connection with duct tape or silicone bathtub caulk.

NOTE: Gas dryer cannot be exhausted through the left side.

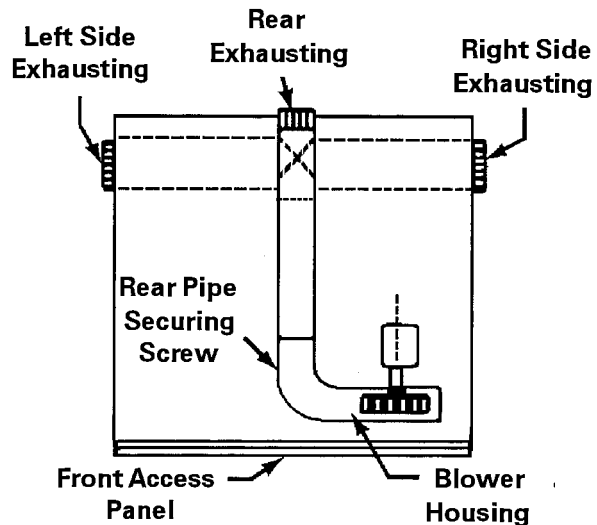

When exhausting from the side, the installation should be made according to the procedures described in the ***Bottom Exhausting*** section and as shown in the previous figure.

Leveling the Dryer

Leveling legs are provided on all four bottom corners of the dryer. Use a level to check and adjust the legs as necessary.

The dryer must rest firmly on all four feet.

SECTION 2. OPERATION

DRYER OPERATION OVERVIEW

When the dryer "push to start" button is depressed to begin the drying operation, it energizes the drive motor and heat source.

NOTE: *If FLUFF on the program selector or WRINKLE RELEASE cycle on the timer is selected, the heat source will not be energized.*

One end of the motor shaft drives the cylinder belt and causes the cylinder to rotate at approximately 49 RPM in all cycles. The other end of the motor shaft drives the blower wheel.

As the blower wheel is driven, cold air is drawn in through louvers in the cabinet rear and heated by either an electric element or a gas burner depending upon the model.

The heated air is drawn in through the rear of the cylinder where it is circulated through the tumbling clothes.

The warm moisture laden air is then drawn down through the lint screen and collector duct, and finally exhausted through the vent duct. The lint screen, located in the collector duct, traps the fine fibers shed by garments in a normal drying process.

The temperature of the air in the cylinder is maintained by a control thermostat located on the blower housing. The thermostat will shut off power to the heat source as the temperature is reached.

When the air flow cools sufficiently to reset the thermostat, the heat source again will be energized until the cool down phase of the cycle is reached.

A high limit thermostat is located above the heat source. In case of air flow interruption, this thermostat will cut off power to the heat source when an approximate temperature of 240 degrees F. (gas model) or 250 degrees F. (electric model) is reached at the **high limit thermostat location**.

PERFORMA dryers are also equipped with a non-resetting thermal fuse in the high limit thermostat area that will open at approximately 300 degrees F. This one time fuse is provided as an additional safeguard should the high limit thermostat malfunction.

OPERATING INSTRUCTIONS

Opening the Door

To open the clothes loading door, pull the handle toward you in a firm manner. A light will illuminate the inside of the cylinder.

NOTE: *The dryer is equipped with a door switch which prevents the dryer from being started if the door is not closed. This door switch will cause the machine to stop anytime the door is opened.*

Lint Screen

The lint screen is located in the bottom of the loading port and is accessible when the loading door is open. The screen can be removed by lifting it straight up until it clears the door opening. Be sure the lint screen is clean and properly located.

Controls

The following is a brief description of the various drying cycles and features available in an automatic dryer. The cycles and features available on any particular unit will vary from model to model.

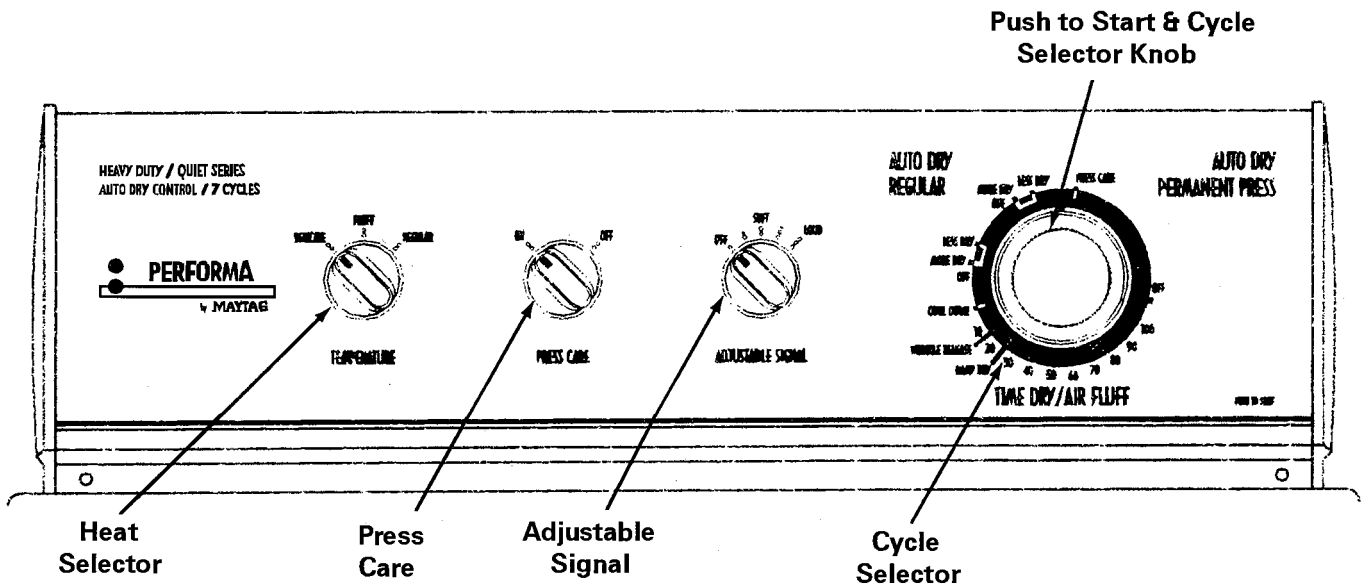

Cycle Selector

The *Cycle Selector* allows the consumer to select the proper drying cycle and to choose the drying time within the cycle.

The cycle selection should be made according to the type of fabric to be dried. The quantity of laundry and the degree of dryness desired should be considered when selecting drying time.

NOTE: *Cycle selection should be made by rotating the selector knob clockwise.*

CYCLES

AUTO DRY PERMANENT PRESS

The *Auto Dry Permanent Press Cycle* is designed to dry all synthetic fabrics,

double knits and permanent press fabrics automatically. At the end of the cycle, the clothes are cooled to reduce wrinkling for approximately 10 minutes. If additional care is needed for drying permanent press clothes, using the **PRESS CARE** option will provide less chance for wrinkling.

PRESS CARE

Press Care is provided to minimize wrinkles and can only be used with the *Permanent Press Cycle*. This wrinkle-out feature provides 60 minutes of unheated tumbling action at the end of the cycle. Clothes can be removed anytime during this portion of the cycle.

AUTO DRY REGULAR

The auto dry regular cycle is designed to dry most cottons and linens. At the end of the cycle, the clothes are cooled to reduce wrinkling for approximately 10 minutes.

TIME DRYER / AIR FLUFF

This cycle can be used to regulate the drying time. This cycle uses either the *Fluff*, *Delicate* or *Regular* temperature control. For timed drying, turn the control dial clockwise until the pointer points to the proper time setting in the *Time Dry/Air Fluff* cycle. For heat sensitive items, use the *Fluff* temperature setting, but this will require a longer drying time.

MORE - VERY DRY/LESS - LESS DRY

In both automatic cycles the timer motor is shunted and will not run if the heating element or the gas burner is on. Heat is supplied to the clothes load which continues to dry until the cylinder temperature climbs high enough to satisfy the control thermostat. When the thermostat is satisfied, the heat circuit opens and energizes the timer motor.

Normally the control thermostat will remain in the satisfied position long enough for the timer motor to terminate the cycle. However, variables such as clothes loads, humidity ambient temperatures, etc., could cause the control thermostat to cycle back to the heat on, timer motor off, position one or more times before the timer motor runs the cycle out.

The cool down period is approximately 10 minutes of the automatic regular and 15 minutes on the automatic permanent press.

SPECIAL OPTIONS

DAMP DRY

Damp dry is located on the *Time Dry/Air Fluff* section of the dial. It is designed to partially dry items. Depending on the temperature selected, it will provide 20 minutes of either heated or non-heated tumbling followed by 5 minutes of cool-down tumbling.

WRINKLE RELEASE

Wrinkle Release will release wrinkles from items that are clean and dry, but only slightly wrinkled. These wrinkles may exist from a crowded closet or suitcase or from sitting in the dryer too long after the end of the cycle. It provides 10 minutes of heated or non-heated tumbling based upon the temperature selected and finishes with a 5 minute cool-down of no heat tumbling.

PUSH TO START

The large control knob located on the timer shaft of the dryer serves as a start switch as well as a cycle selector (*see previous figure*).

After the knob has been rotated to the desired drying cycle and/or time, it should be depressed momentarily to begin dryer operation.

OPERATION TEST

After installing or servicing the dryer, the following should be performed to ensure the unit is functioning properly. Refer to the Installation and *Operating Instructions* selections if necessary.

1. Open the clothes loading door and check inside the cylinder to make sure it is free of objects. Close the door securely.
2. Turn gas valve on and plug the unit in (*gas model*). Close electrical disconnect (*electric model*).
3. Turn the cycle selector knob clockwise to the desired cycle and drying time.
4. Select the proper program selector setting.
5. Depress the push to start knob momentarily to begin dryer operation.
6. Allow the dryer to operate with heat for a few minutes then stop the dryer by opening the door. Wipe any dirt from inside the cylinder.
7. Close the door and *depress the push to start* knob and resume operation.
8. The dryer will stop automatically at the end of the cycle.
9. Restart dryer and operate briefly on all control settings.
10. Wipe fingerprints and dirt from the outside of dryer using a soft cloth.
11. Briefly explain the dryer operation to the consumer using the instruction book.
12. Advise the customer where to call to obtain authorized service if the need should arise.

NOTE: *On gas models the burner is automatically lit by an electric igniter. The ignition may be heard directly after the dryer has been turned on and at intervals throughout the drying period, as the burner will cycle on and off to maintain the selected cylinder temperature.*

SECTION 3. CABINET ASSEMBLY COMPONENTS

CABINET AND BASE ASSEMBLY

The cabinet and base assembly (*see figure on page 3-2*) consist of an enameled steel cabinet body and base assembly which are fastened together in a unitized assembly.

The rear and both sides of the dryer cabinet are formed from a single sheet of steel in a "U" shaped configuration. The dryer base, which is formed of heavy gauge steel, has the cylinder support, plate (for the motor bracket) and the leveling leg nuts assembled to it.

The dryer base assembly is permanently attached to the cabinet at the front corners and the cabinet rear which unitizes the assembly. The cabinet sides are secured to the base by sheet metal screws.

The cabinet and base assembly provides mounting for the following hardware: Top hinges and pads, front panel bumpers, clips (front panel to base), front panel locating pins, cylinder light socket and bulb and the supply cord support cover.

TOP ASSEMBLY

The top assembly (*see figure on page 3-2*) consists of an enameled steel top panel with the backguard assembly mounted to it.

The top assembly is mounted to the cabinet assembly by two (2) galvanized steel hinges which are attached to the cabinet rear, near the top, by two (2) screws. These hinges fit into slots located in the back edge of the top panel and allow the top assembly to be raised for servicing.

Two (2) holes pierced in the front flange of the top panel align with two (2) locating pins which are mounted on the upper flange of the front panel. These pins serve to locate and center the top assembly. Two (2) spring clips, also mounted on the upper flange of the front panel approximately four (4) inches in from either side, serve to lock the top assembly down.

The following components can be accessed by raising the top assembly:

- Door Catch
- Cylinder Light Bulb
- Cylinder Light Lens
- Hi-Limit Thermostat
- Heater Element (Electric Model)

The top assembly can be raised by pressing in on the two (2) spring clips with a thin bladed instrument such as a putty knife and lifting the top assembly upward.

NOTE: *When the top assembly is raised, make sure it is restricted from going past the perpendicular position to prevent deforming of the hinges, cabinet rear and top panel flange.*

CABINET ASSEMBLY

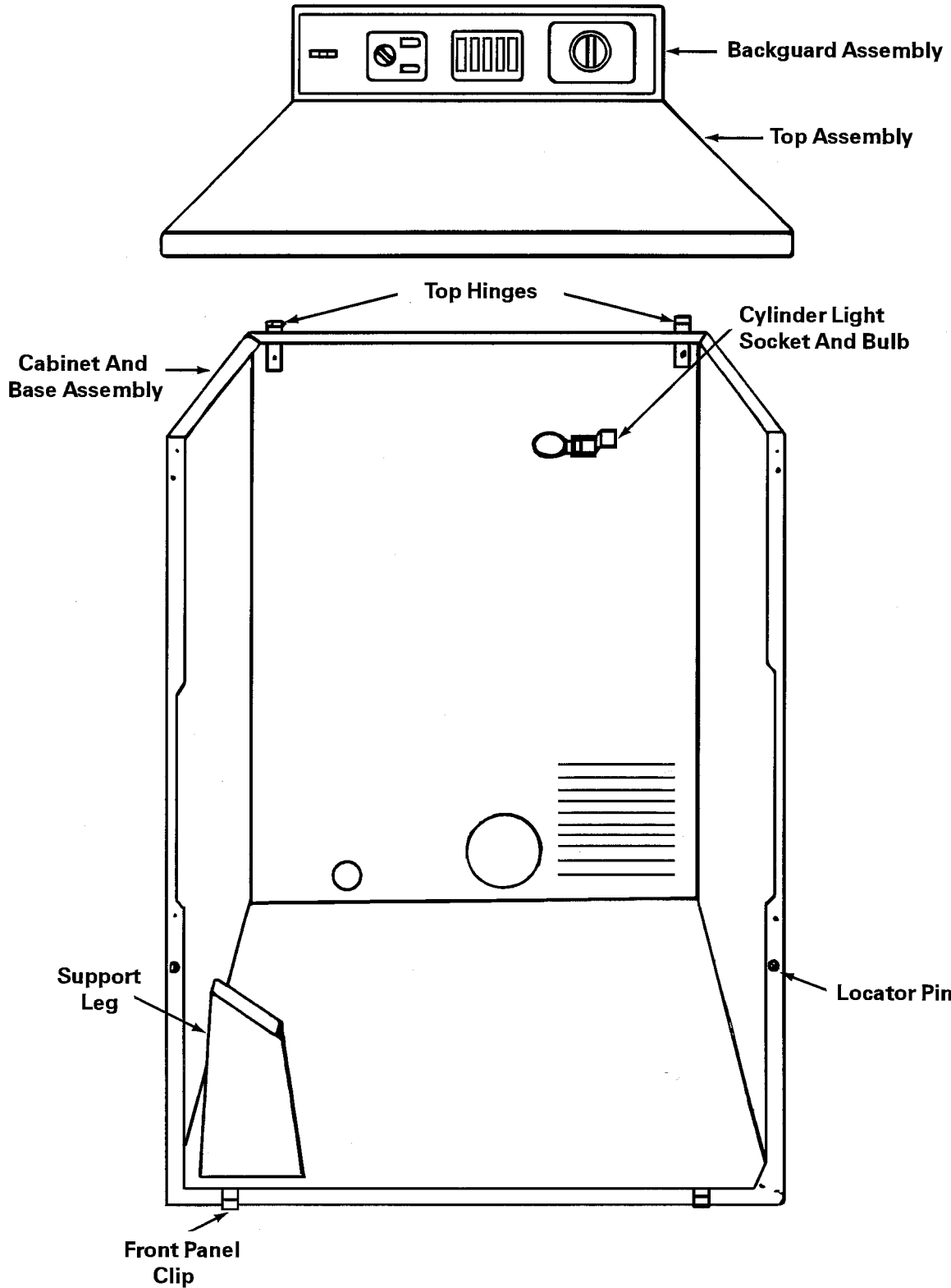

FRONT PANEL ASSEMBLY

The front panel assembly (*see the following figure*) consists of the following components: Enameled steel front panel, the collector duct assembly, door assembly, front seal, top clips, top locator pins, top bumpers, door switch, door catch, door hinges and clips.

The front panel on gas model dryers has a plug and plug button located at the bottom. Removal of the **plug button** allows access to the main gas shut off valve.

REMOVAL

1. Disconnect the unit from the power source.
2. Raise the top assembly

3. Remove the two (2) screws located inside the top corners of the front panel which secure the front panel flange to the cabinet flange.
4. Tilt the front panel forward.
5. Disconnect door switch wires and lift front panel up to disengage slots in bottom flange of front panel from the retaining clips on bottom flange of cabinet and base assembly.

The following components can be accessed by removing the front panel assembly:

- Control Thermostats
- Door Switch
- Control Valve and Burner (Gas Model)

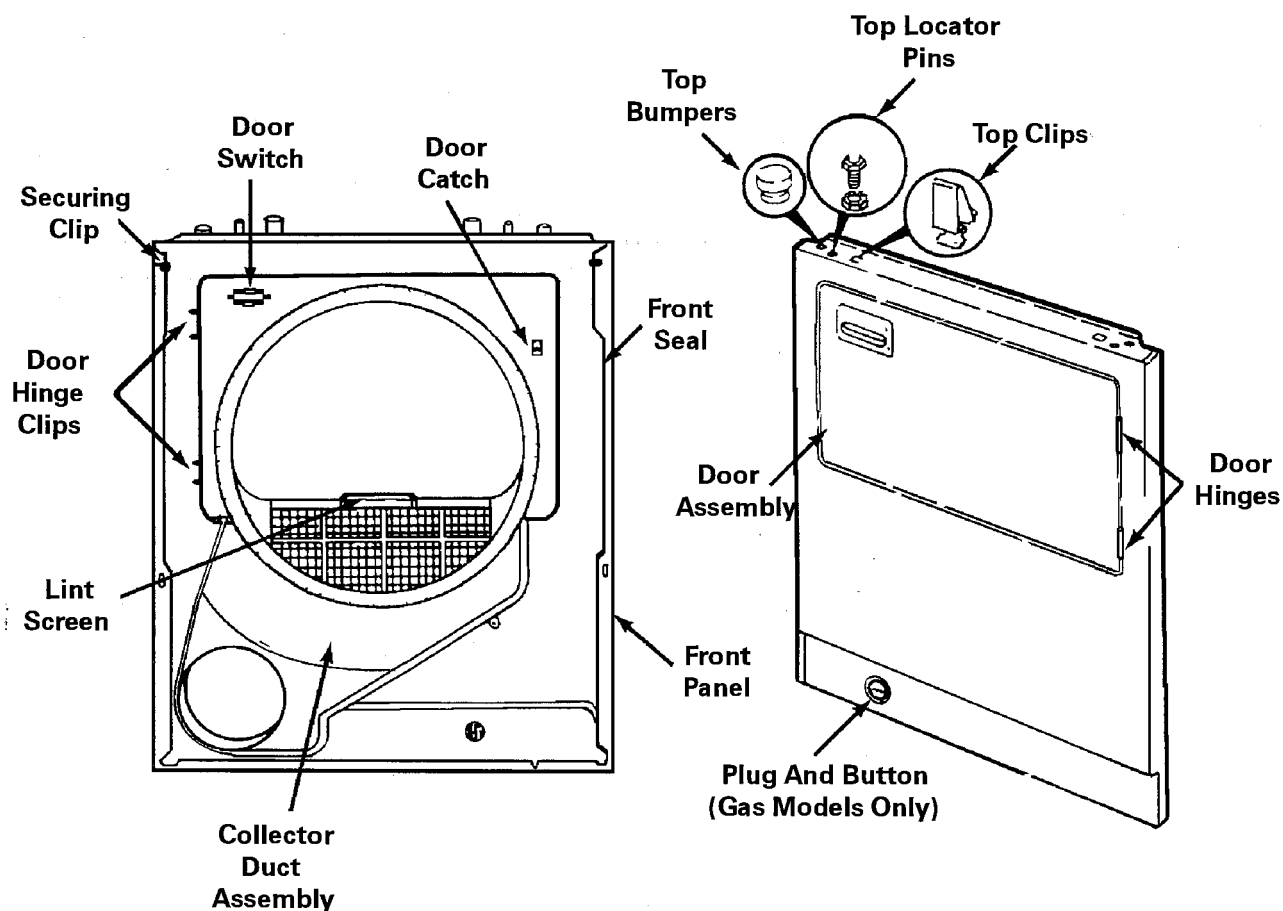

COLLECTOR DUCT ASSEMBLY

The purpose of the collector duct assembly (*see previous figure*) is to conduct the air flow from the cylinder to the blower exhaust port, and to provide a mounting location for the lint screen.

It consists of a molded plastic collector duct, foam seal and the lint screen locating bracket. The lint screen slips down between guides molded into the collector duct and locates against the clip.

The collector duct assembly is located inside the front panel directly below the door opening. It engages into and mates with the inner flange of the door opening to provide for the mounting of the cylinder front seal. The assembly is secured to the front panel by two (2) screws located on the outside of the panel below the door opening.

The foam seal attached to the collector duct assembly provides a seal between the collector duct and the front panel. This ensures an efficient air flow from the cylinder through the collector duct. Minor gaps between the foam seal and the front panel, caused by design configurations, have been sealed with Permagum.

REMOVAL

1. **Disconnect unit from power source.**
2. Open the clothes loading door.
3. Remove the two (2) screws located directly below the door opening.
4. Shut the clothes loading door and remove the front panel assembly.
5. Lay the front panel assembly ***face***

down on a padded surface to prevent damage.

6. Remove the cylinder front seal from the collector duct assembly.
7. Carefully pry outward on the top corners of the collector duct to disengage the locating slot in the duct from the front panel inner flange.
8. When the top of the duct is clear, pull out and lift up to release a lower locking tab from a slot located in the front panel inner flange

NOTE: *During reassembly, make sure to:*

- Insert the lower locking tab in the bottom flange slot before engaging the top.
- Engage the location slot in the top of the collector duct to the front panel inner flange.
- Use a quality contact cement and affix the cylinder front seal to the collector duct in its previous position.
- Replace Permagum as required.

The following component can be accessed by removing the collector duct assembly:

- Collector Duct Foam Seal

DOOR ASSEMBLY

The door assembly (*see following figure*) consists of a steel inner and outer panel

assembled together with styrofoam pads installed between them for increased rigidity. The model/serial plate is located on the inner door panel. The door handle fits into a cut-out on the outer door panel and is secured by two screws which thread into it from the inner panel side.

The door strike and hinge clips are attached to the inner door panel and must be released from the backside. Therefore, it is necessary to remove and disassemble the door assembly to remove these parts.

The door assembly is mounted to two (2) chrome hinges attached to the front panel. The door assembly is secured to these hinges by four (4) screws.

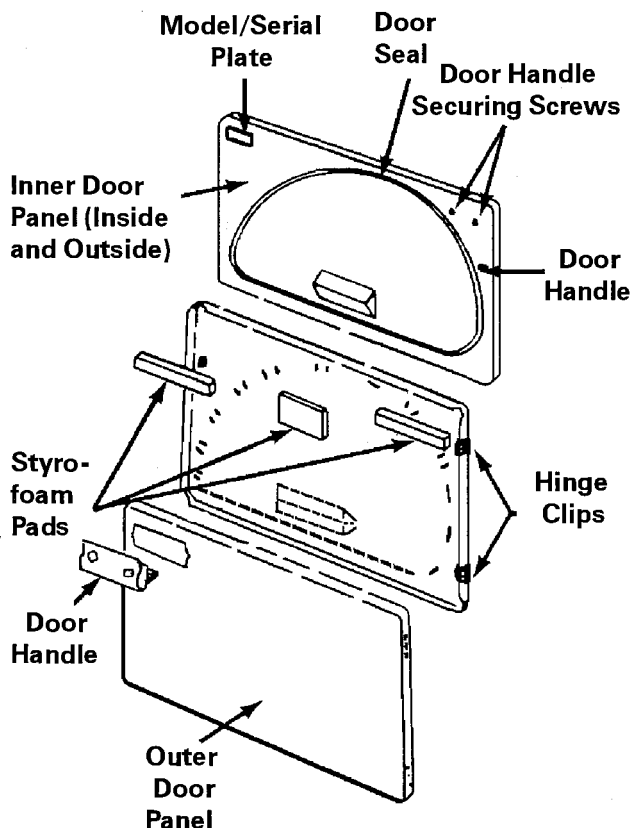

REMOVAL

1. **Disconnect the unit from the power source.**
2. Open the clothes door.
3. Remove the four (4) screws which secure the door assembly to the hinges.

DISASSEMBLY

1. Remove the two (2) screws which secure the door handle through the inner door panel.
2. Lay the door assembly down, seal side up, on a well padded surface to prevent scratching the outer panel.
3. Remove the plastic plug located beside the screw on the edge of the right bottom corner. This is best accomplished by slipping a thin blade under the head and prying it out.
4. Remove the four (4) screws located around the edge of the door assembly.
5. Using the door seal, carefully lift the bottom of the inner door up until it clears the outer door flange, then slide it down to release the inner door panel from the retaining flange on the top of the outer door panel.
6. The seal, door strike or the hinge clips can now be accessed for removal.

NOTE: *Anytime an inner door panel is replaced, be sure to record all information included on the model/serial plate and give it to the consumer for future reference.*

DOOR SEAL

The door seal is positioned and secured to the inner door panel by barbed tabs molded into the seal. The tabs are inserted through slots in the inner door panel and the barbed design restricts their withdrawal.

The old seal can be removed for replacement by pulling the tabs from the inner door panel slots in a firm manner.

NOTE: *Since some damage to the seal may occur when pulling the tabs from the slots, this removal method should only be used when replacing the door seal.*

Non-destructive seal removal can best be obtained by disassembling the door, compressing the seal barbs from the back and pushing them through the inner door panel slots.

When installing the new seal, start at the long slot located at the bottom center of the inner door panel so the seal splice will be located at the bottom. Insert each tab into its proper slot and push until the barbs are locked in place.

SECTION 4. CYLINDER ASSEMBLY AND RELATED PARTS

The cylinder assembly and related parts as shown in the following figure consists of the cylinder assembly, cylinder belt, support rollers and glide, front seal and the rear seal.

The cylinder assembly is supported at the rear by two (2) rollers mounted on the bottom of the bulkhead. Teflon glides mounted on top of the blower housing and attached to the cylinder leg support the cylinder assembly in front.

The cylinder assembly is rotated at approximately 49 RPM by the cylinder belt which is driven by the motor pulley. The idler assembly and spring maintain tension on the belt.

Perforations in the heat source inlet ducts channel the flow of heated air into the cylinder rear. The baffles mounted inside the drum keep the clothes tumbling in the air flow to ensure the load is evenly dried. The front and rear seals contain the air flow within the cylinder assembly.

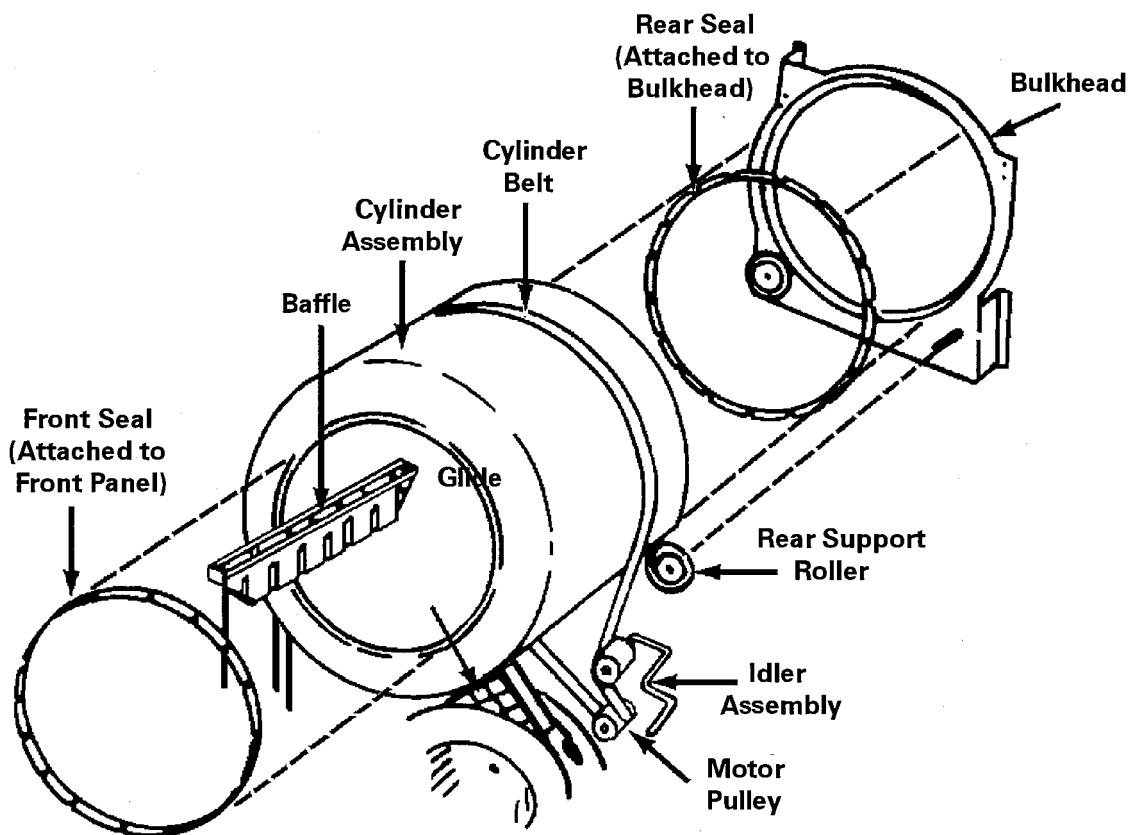

CYLINDER ASSEMBLY

The cylinder is fabricated from a one piece wrapper that has been seam welded and expanded under extreme pressure.

The front, rear and body of the cylinder are formed during the expanding process.

Three (3) heat resistant plastic baffles are mounted equidistant around the inside of the drum. Each baffle is attached to the cylinder by four (4) screws.

REMOVAL

1. **Disconnect the unit from the power source.**
2. Raise the top assembly.
3. Remove the front panel.
4. Reaching between the top of the blower housing and the side of the cabinet, force the idler pulley to the right and remove the cylinder belt from the motor pulley.
5. Using the belt, lift the rear of the cylinder assembly off the rollers and pull forward to remove.

NOTE: When replacing the cylinder assembly, push the rear lip of the cylinder over the support rollers and rotate the cylinder 1/4 turn counterclockwise to engage the rollers. This can best be accomplished by looking through the cylinder.

The following components can be accessed by removing the cylinder assembly:

- Blower and Drive Module
- Support Rollers and Glides
- Wiring Harness
- Burner Housing and Sensor (gas model)
- Rear Seal
- Terminal Block (electric model)

CYLINDER BELT

The cylinder belt is a four (4) rib poly-"V" type that encircles the cylinder assembly, **rib and groove side down.**

The belt is driven by a multi-"V" motor pulley which caused the cylinder assembly to rotate during drying cycles. The idler assembly and spring maintain the proper tension on the belt.

REPLACING BELT

1. **Disconnect the unit from the power source.**
 2. Remove the front panel.
 3. Lift the front of the cylinder up far enough to slip the belt between the glide and cylinder.
 4. Locate the belt on the cylinder, rib and groove side down.
 5. Reaching between the top of the blower housing and side of the cabinet, force the idler assembly to the extreme right and slip the belt over the motor pulley.
- NOTE: Install the belt as shown in the illustration making sure the rib and grooves in the belt engage the rib and grooves in the motor pulley.**
6. Rotate the cylinder counterclockwise to align the belt around the cylinder.

CYLINDER SUPPORT ROLLERS AND GLIDE

The cylinder assembly rests on two (2) roller support assemblies at the rear and glide assemblies in the front (*see the following figure*).

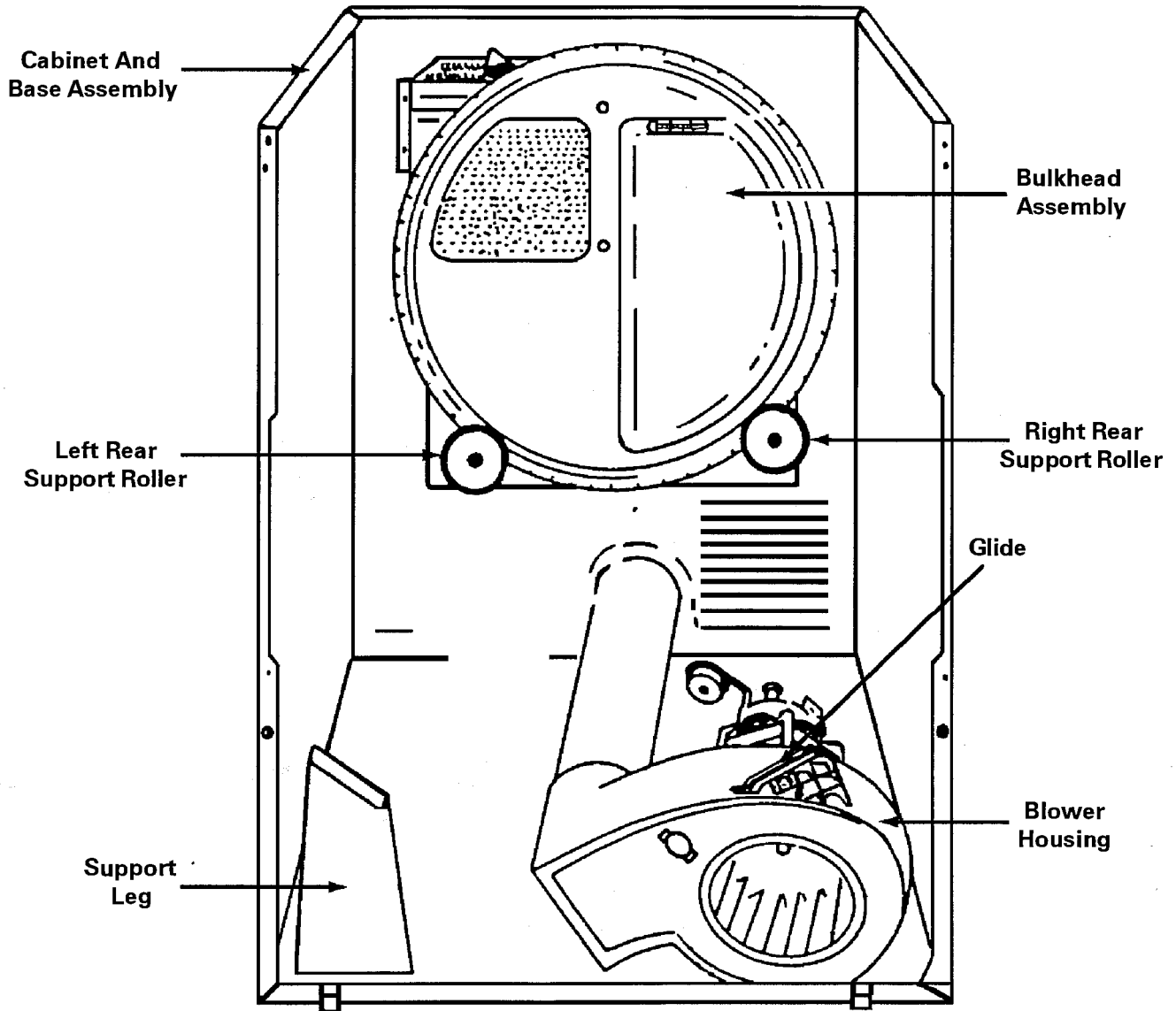

REAR ROLLER SUPPORT ASSEMBLIES

The rear roller assemblies are mounted on the lower corners of the bulkhead. These roller assemblies support the rear of the cylinder by riding on the outside of a lip formed into the cylinder rear.

To ensure proper cylinder support and alignment during rotation, it is necessary

for the left rear roller to have slightly more "play" in it than the right. This allows the left roller to track around any minor imperfections the cylinder lip might have incurred during its forming process while the right roller maintains the necessary alignment.

The "play" is provided in the left rear roller by **omitting** the two (2) polyethylene spacers that are included in the right roller assembly (*see the following figures*).

NOTE: *Some models may be equipped with one thick (3/32") spacer instead of two (2) thin (3/64") spacers.*

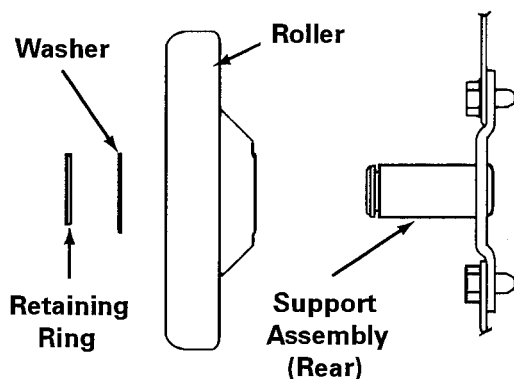

Left Rear Roller Assembly

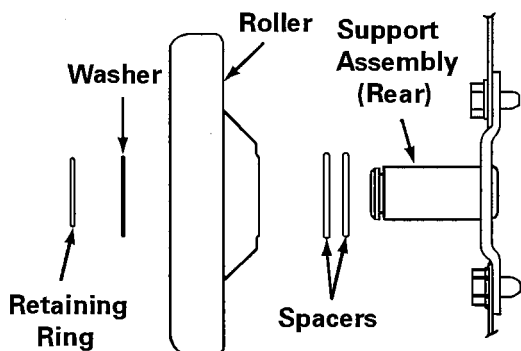

Right Rear Roller Assembly

REMOVAL (Rear Roller Assemblies)

1. Disconnect the unit from the power source.
2. Remove the front panel assembly.

3. Remove the cylinder assembly.
4. Remove the retaining ring from the end of the shaft.
5. Slide the washer, roller and spacer (if equipped) from the shaft.
6. Remove the two (2) screws which mount the shaft assembly.

NOTE: *The left rear shaft assembly can be withdrawn from the front by rotating in slightly and pulling the mounting plate through the hole. The right rear shaft assembly can be extracted from the bottom of the bulkhead and the support leg respectively.*

GLIDE ASSEMBLY

The glide assembly supports the right front of the cylinder assembly and a second glide assembly mounted on the left support leg. It is mounted to a support leg which has been molded on the top of the blower housing. The leg is radiused so it and the glide assembly conforms to the curvature of the cylinder. The glide assembly consists of a cushion assembly and Teflon glide.

The cushion assembly is made up of a steel clip with a felt pad cemented to it. The assembly slips into two (2) securing slots which are formed into the radiused section of the leg. The cushion assembly serves to protect the Teflon glide during start up.

The glide is a strip of Teflon approximately 6 3/4" inch long with two (2) notches in one end. It mounts over the cushion assembly and is secured to the leg at each end of the radiused section.

The notched end of the glide engages a pair of pins located under a tab molded on the blower housing. The other end of the glide is inserted into a slot formed into the top of the leg.

REMOVAL

1. **Disconnect the unit from the power source.**
2. Remove the cylinder assembly.
3. Remove the end of the Teflon glide from the slot.
4. Rotate the glide 180 degrees to disengage the notched end from the pins.
5. Lift up on the cushion assembly to remove.

FRONT AND REAR SEALS

The front and rear seals serve to confine the air flow within the cylinder assembly. The seals are identical and are fabricated of a felt-like, polyester material.

The front seal is attached to the inner door flange and collector duct on the inside of the front panel assembly.

The rear seal is attached to the outer perimeter of the bulkhead assembly which is mounted to the inside of the cabinet back.

Both seals have been cemented in position then folded back for increased efficiency.

FRONT SEAL REPLACEMENT

1. **Disconnect the unit from the power source.**
2. Remove the front panel assembly.
3. Lay the front panel assembly **face down** on a padded surface to prevent damage.
4. Remove the old seal and clean off any residue remaining on the flange and collector duct.
5. Cover the seal area of the flange and collector duct with a **quality** contact cement.
6. Install the **unslit** side of the seal over the cemented area.

NOTE: *Make sure the section around the collector duct is on as far as it will go, then align the upper section to it.*

7. Fold the seal back and make any final alignment adjustment.

NOTE: *Allow the cement to set before reassembling the front panel assembly to the unit.*

REAR SEAL REPLACEMENT

1. **Disconnect the unit from the power source.**
2. Remove the front panel assembly.
3. Remove the cylinder assembly.
4. Remove the retaining rings which secure the rear support rollers and remove the rollers.

5. Remove the old seal and remaining residue.
6. Cover the seal area of the bulkhead with a quality contact cement.
7. Install the ***unslit*** side of the seal over the cemented area as far as possible.

8. Fold the seal back and make any final positioning adjustments.

NOTE: *Allow the cement to set before reassembling the unit.*

SECTION 5. BLOWER AND DRIVE MODULE

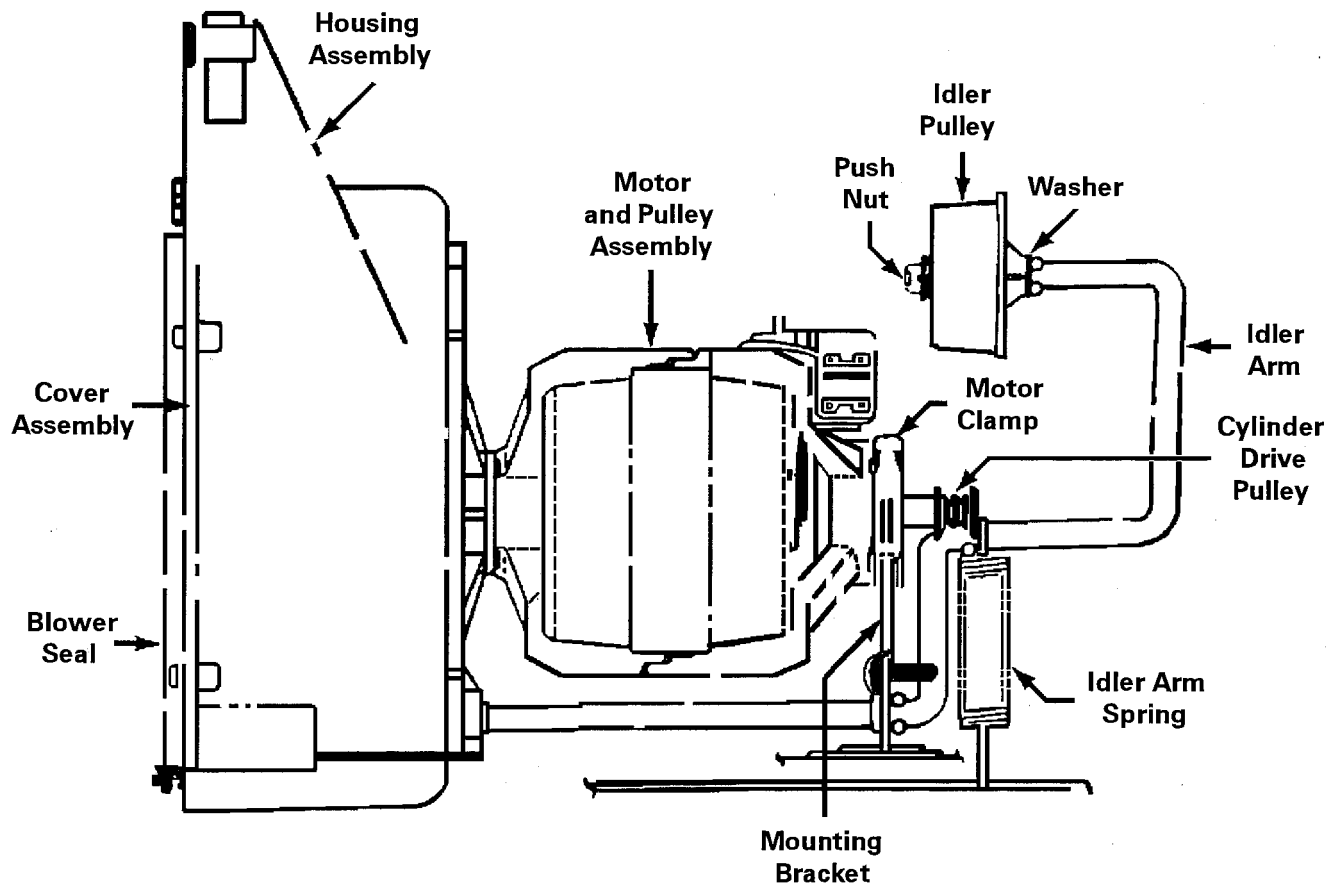

Blower and Drive Module

The blower and drive module consists of the blower assembly, motor and pulley assembly, idler arm assembly and the galvanized steel bracket to which they are mounted.

The module is located on the right front corner of the cabinet base. It is positioned on the base by two (2) step down tabs formed on the rear of the mounting bracket which inserts into mating slots on the base. The module is then secured to the base.

NOTE: *It is not necessary to remove the entire module from the base to service or replace any of its components except the blower housing. However, if module removal is desired for easier access to the components, it can be accomplished as detailed below:*

REMOVAL

1. **Disconnect the unit from the power source.**
2. Remove the front panel.

3. Remove the cylinder assembly.
4. Remove the harness wiring to the thermostats and motor.
5. Remove the screws which secure the module to the cabinet base.
6. Remove the vent duct tape, screw and vent duct from the module.
7. Lift the module up and out of the cabinet base slots.

The mounting flange on the blower end of the motor and the rear opening of the blower housing have been designed to interlock together to support the motor front. This interlocking is accomplished by engaging the motor flange firmly into the blower housing rear, and rotating the motor frame approximately 1/4 of a turn.

The motor rear is supported by a small mounting bracket attached to the dryer base, and is secured to the bracket with a spring clip motor clamp. The motor ground wire screw protrudes through the rear mounting bracket and also serves as a stop for the idler assembly.

BLOWER ASSEMBLY

The blower assembly consists of the cover assembly, blower wheel and the housing assembly.

The assembly intakes the warm moisture laden air from the collector duct and exhausts it through the vent duct.

COVER ASSEMBLY

The cover assembly will consist of a sheet metal cover, the control thermostat, a foam seal and an inlet guide vane.

The ***control thermostat*** is mounted over clearance hole located in the cover. This hole permits the sensing side of the thermostat to protrude inside the blower assembly and monitor the air flow temperature. The thermostat is attached to the cover by two (2) screws and can be removed accordingly.

The ***foam seal*** is self adhering and provides an air tight connection between the collector duct and the air intake of the blower assembly.

The ***inlet guide vane*** is secured to the cover with a single mounting screw. The vane protrudes into the blower area where it reduces blower turbulence and provides a better air flow through the exhaust system.

REMOVAL

1. **Disconnect the unit from the power source.**
2. Remove the front panel and cylinder assembly.
3. Disconnect the harness wiring from the control thermostat.
4. Remove the two (2) screws which pass through the bottom tabs and into the base.
5. Remove the nine (9) screws around the front edge which secure the cover assembly to the housing.
6. Lift off the cover assembly.

BLOWER WHEEL

The molded plastic blower wheel generates the air flow throughout the dryer. It is mounted to the front motor shaft and is enclosed by the blower housing.

The blower wheel has a split hub with a "D" hole molded through it. The hub slips on a mating "D" section of the motor shaft by a clamp spring and a retaining ring. A second retaining ring is located on the shaft behind the wheel to position it.

REMOVAL

1. **Disconnect the unit from the power source.**
2. Remove the cover assembly as previously described.
3. Remove the retaining ring from the end of the shaft.
4. Remove the clamp spring by squeezing in on the ears and slipping it off the shaft.
5. Withdraw the blower wheel from the motor shaft.

HOUSING ASSEMBLY

The housing assembly is constructed of molded plastic. It has the right cylinder support leg formed on its top, and the exhaust port is on its left rear.

The cover assembly is fastened to the front of the housing assembly; the glide and cushion assembly mount to the support leg; and the vent duct attaches to the exhaust port by a securing screw and duct tape.

The mounting flange on the blower end of the motor interlocks into the rear opening of the blower housing to support the motor front. The motor rear is supported by a small mounting bracket which is secured to the dryer base.

REMOVAL

1. **Disconnect the unit from the power source.**
2. Remove the cover assembly and the blower wheel as previously described.
3. Disconnect the harness wires and ground wire to the motor.
4. Remove the spring clip motor clamp.

NOTE: *This is best accomplished by placing a screwdriver blade in the turned up portion of the clamp end.*

5. Rotate motor to unlock it from housing rear.

Motor testing is detailed in **Section 8** of this manual.

NOTE: *The cylinder drive pulley has been threaded onto the end of the motor shaft. Because of its steel construction, and insignificant failure rate, removal of the pulley in the field is both impractical and unnecessary. For this reason, all service replacement motors will come with the cylinder drive pulley already installed.*

IDLER ASSEMBLY

The idler assembly denotes the idler arm assembly and the spring which serves to maintain the proper tension on the cylinder belt.

The idler arm assembly consists of the idler arm formed from a 3/8" diameter steel rod with a plastic idler pulley assembly attached to one end.

The other end of the idler arm is inserted through extruded holes pierced into the motor support which allows the arm to pivot. The arm is kept in position through the holes by pinch tabs swagged into the arm.

One end of the idler arm spring encircles the idler arm and is retained in working position by two (2) more pinch tabs. The other end of the spring hooks into a hole located in a slot in the base.

NOTE: *The push nut which secures the idler pulley on the idler arm must be removed before the pulley can be withdrawn from the arm. In most cases, removing the push nut from the arm end will damage it to the extent that it cannot be reused. Therefore, when installing an idler pulley, make sure to use a new push nut.*

REMOVAL

1. Disconnect the unit from the power source.
2. Remove the front panel and the cylinder assembly.
3. If present, remove the retaining ring located on the idler arm just inside the rear motor support.

4. Unhook the spring.
5. Withdraw the idler assembly from the motor support(s).

MOTOR AND PULLEY ASSEMBLY

The motor and pulley assembly consists of a double shaft motor with a steel multi-"V" cylinder drive pulley assembled onto the rear shaft. The front shaft of the motor extends through a hole in the rear of the blower housing and has the blower wheel mounted on it.

During motor operation, the multi-"V" pulley drives the cylinder belt which rotates the cylinder and the blower wheel generates the air flow throughout the dryer.

The mounting flange on the blower end of the motor interlocks into the rear opening of the blower housing to support the motor front. The motor rear is supported by a small mounting bracket which is secured to the dryer base.

REMOVAL

1. Disconnect the unit from the power source.
2. Remove the cover assembly and the blower wheel as previously described.
3. Disconnect the harness wires and ground wire to the motor.
4. Remove the spring clip clamp.

NOTE: *This is best accomplished by placing a screwdriver blade in the turned up portion of the clamp end. Push down and pry outward at the same time.*

REMOVAL

5. Rotate the motor to unlock it from the housing rear.

Motor testing is detailed in **Section 8** of this manual.

NOTE: *The cylinder drive pulley has been threaded onto the motor shaft. Because of its steel construction and insignificant failure reate, removal of the pulley in the field is both impractical and unnecessary. For this reason, all service replacement motors will come with the cylinder drive pulley already installed.*

SECTION 6. HEAT SOURCE AND RELATED PARTS

This section covers the heater assembly on electric model, gas control and burner assembly on gas model, and the bulkhead assembly on all models.

The heater assembly or the gas control and burner assembly provides the heat source which the bulkhead assembly channels into the cylinder area. Related components are also included.

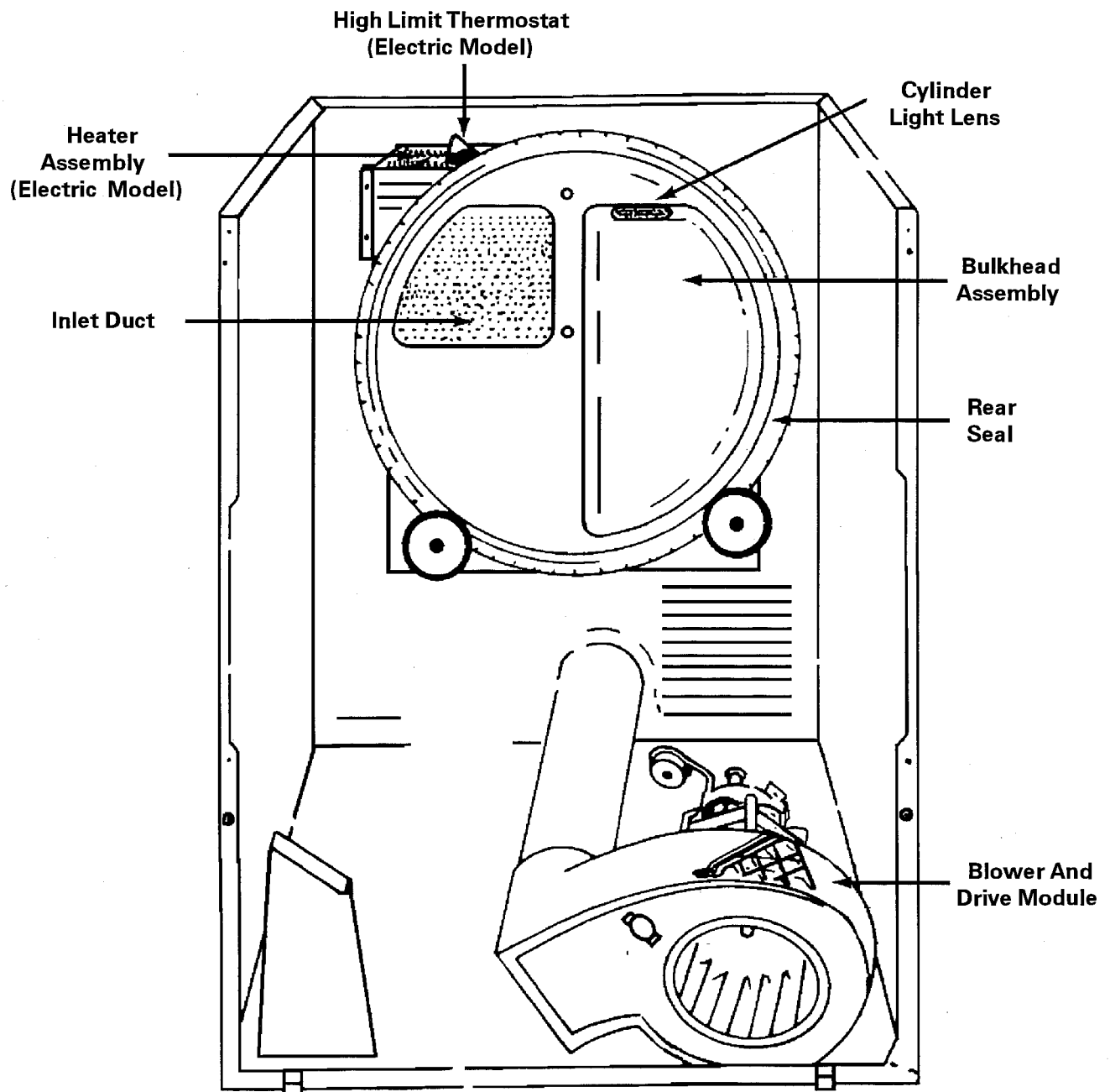

HEAT SOURCE AND RELATED PARTS (ELECTRIC MODEL)

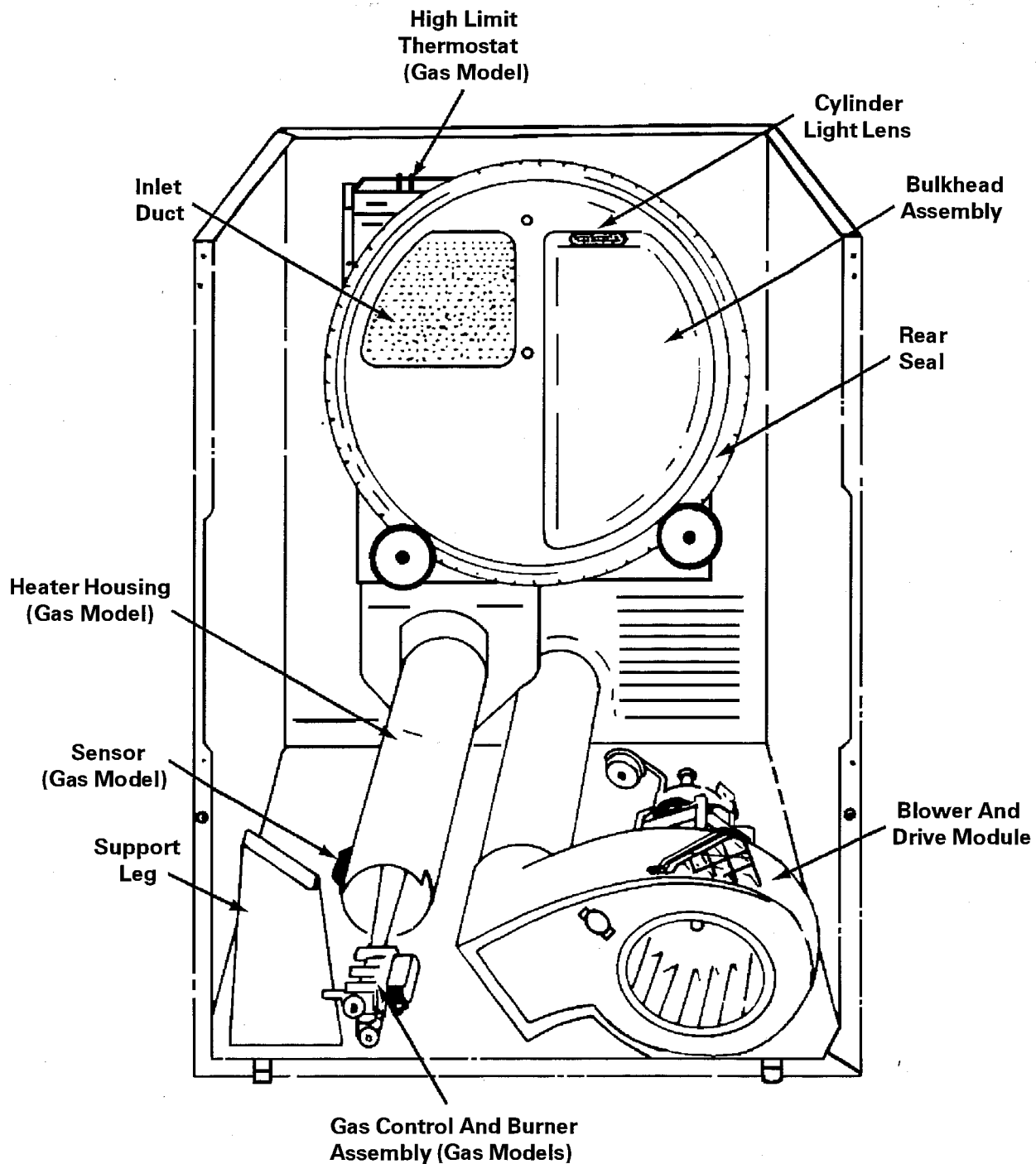

HEAT SOURCE AND RELATED PARTS (GAS MODEL)

HEATER ASSEMBLY

All electric model dryers are equipped with a heater assembly which is located behind the upper left quadrant of the bulkhead. It consists of the heater housing and the heater element assembly. The housing is attached to the rear of the

bulkhead and the element readily mounts within the housing.

The heater element assembly is made up of a coiled wire element held in position around a steel mounting bracket by a

series of ceramic insulators. The element is terminated with a ceramic terminal block assembly which is attached to the mounting bracket. Male terminals in the block accept the heater harness wiring.

NOTE: *The heater element assembly is serviced as a completely assembled unit ready to be mounted into the heater housing.*

HEATER ELEMENT ASSEMBLY REMOVAL AND REPLACEMENT

1. Disconnect the unit from the power source.
2. Raise the top assembly.
3. Disconnect the harness wiring to the element assembly.
4. Remove the screw which secures the high limit thermostat bracket to the top of the bulkhead. Allow the thermostat and bracket to hang out of the way.
5. Remove the screw located below and to the left of the ceramic terminal block. This screw secures the right side of the element assembly mounting bracket to the heater housing.
6. Lift up on the right side of the assembly, tip it slightly forward, then work the rod end of the bracket out of the housing location hole. Withdraw the assembly from the top.

REPLACEMENT is a reversal of the above procedures.

Heater element specifications are detailed in **Section 8** of this manual.

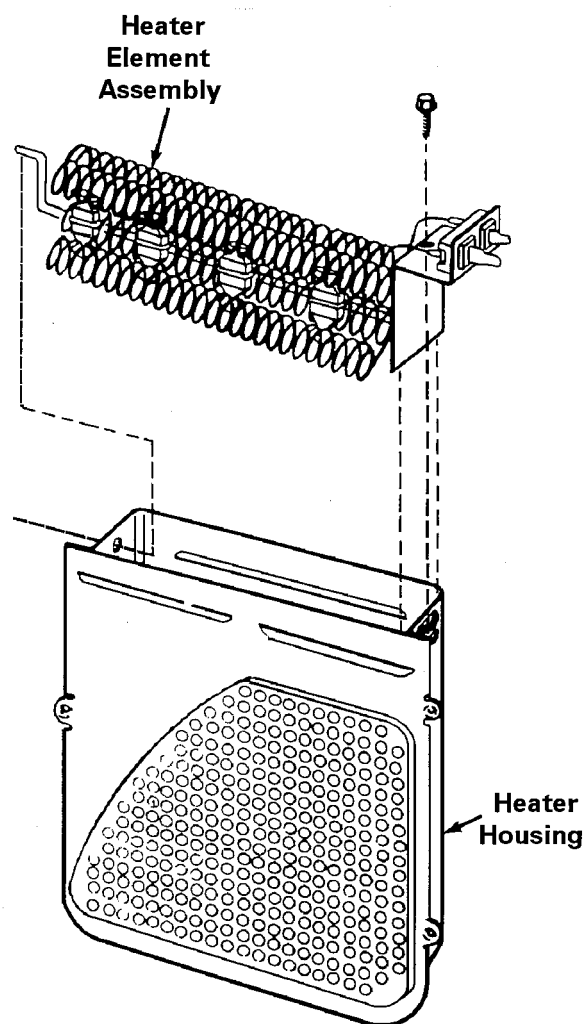

GAS CONTROL AND BURNER ASSEMBLY

The heat source for the gas model dryer is provided by the gas control valve and burner assembly. The assembly is equipped with a silicone carbide ignition system.

The valve/burner/ignition system is assembled together as a unit and consists of the following components: burner assembly and bracket, gas control valve, igniter and bracket, shut off valve and gas pipe assembly.

The assembly is attached to the front cylinder support leg and is located below and to the left of the cylinder.

The flame sensor is mounted to the side of the steel heater housing. The housing and sensor assembly is mounted in front to a support which is attached to the

cabinet base. Tabs formed in the rear of the housing connect the assembly to the inlet duct.

The burner assembly protrudes into the front of the heater housing which channels the heat from the burner into the inlet duct and upward into the cylinder rear.

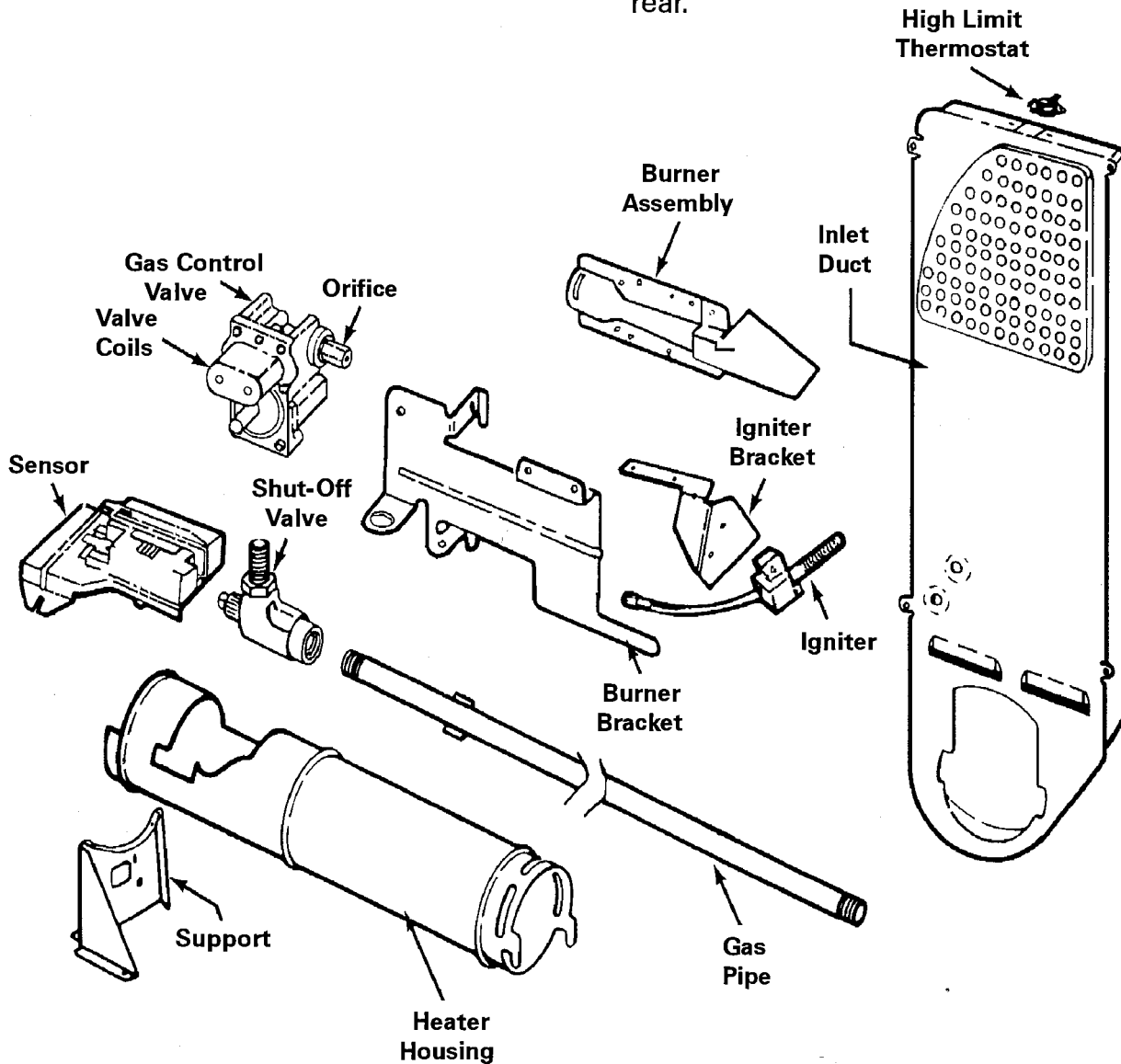

SILICON CARBIDE IGNITION SYSTEM

The silicon carbide ignition system is made up of six (6) basic components.

- Gas Control Valve
- Holding Coil
- Booster Coil
- Secondary Coil
- Flame Sensor
- Silicon Carbide Igniter

The three (3) coils are mounted on the gas control valve. The flame sensor is mounted in a cut out on the heater housing, and the igniter mounts on the burner. The function of each of the six components is as follows:

Gas Control Valve

The gas valve has two (2) solenoid controlled valves. The split coil valve controls the flow of gas from the pressure regulator to the secondary valve. The secondary valve controls the flow of gas from the gas valve body to the burner (*see the following figure*).

Holding Coil

When the holding coil is energized, it creates a magnetic field that is sufficient to hold the plunger of the split coil valve open. It is not, however, strong enough to lift the plunger if its in the closed position.

Booster Coil

When the booster coil is energized, it creates a magnetic field which adds to the magnetic field of the holding coil. The combined fields are sufficient to open the split coil valve which allows gas to flow to the secondary valve.

Secondary Coil

The secondary coil has two (2) functions when it is energized; it opens the secondary valve allowing gas to flow to the burner, and its resistance reduces the current flow through the igniter and booster coil from four (4) amperes to .1 amperes.

Flame Sensor

The flame sensor is mounted on the outside of the heater housing next to a "window" or cutout. The window allows the flame sensor, which is normally closed S. P. S. T. switch, to react to the heat provided by either the igniter or the burner flame. When the heat is sufficient, the sensor opens its contacts,

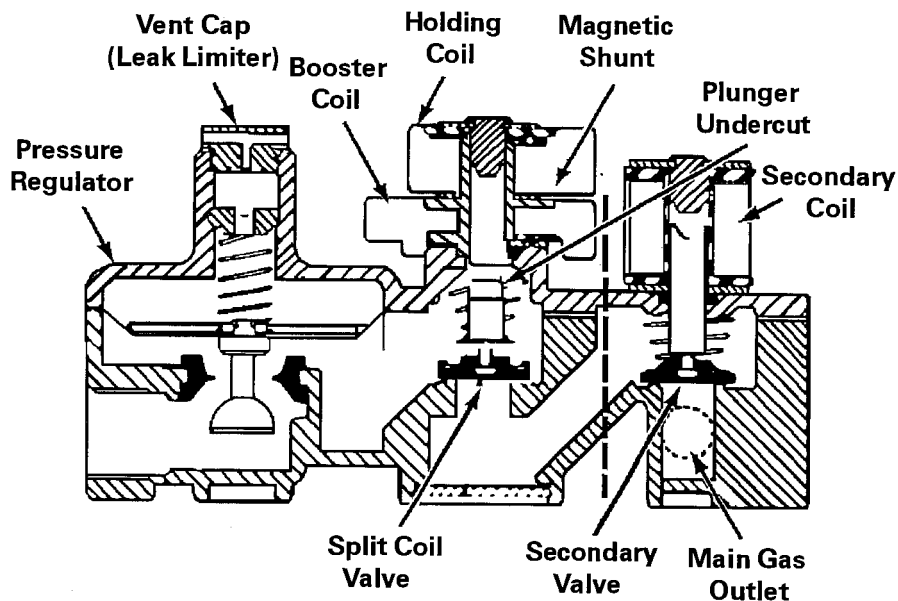

energizing the secondary coil. When its contacts are closed, it provides a path or shunt around the secondary coil.

NOTE: *During either automatic dry cycle when the sensor contacts close, it provides a circuit to energize the timer motor.*

Silicon Carbide Igniter

The igniter is mounted on the burner with its end protruding into the gas flow area. When the ignition cycle starts, the igniter heats to a temperature of about 1800 degrees F. in 20 to 80 seconds.

CIRCUIT OPERATION

Following is a description of the operation of the silicon carbide ignition system in each of its various stages. The active part of the circuits for each of these stages is shown as a heavy dark line in the following figures:

Normal Ignition - Start

When the thermostat calls for heat, voltage is applied to the blue wire, energizing the holding coil by a circuit through the holding coil to common. A second circuit is simultaneously made through the flame sensor, igniter and booster coil causing the igniter element to begin heating and the split coil valve to open.

The combined magnetic field of the holding and booster coils are required to open the split coil valve allowing gas to flow to the secondary valve. The secondary coil is **NOT** energized because the flame sensor provides a path or shunt

around the coil (*see the following figure*).

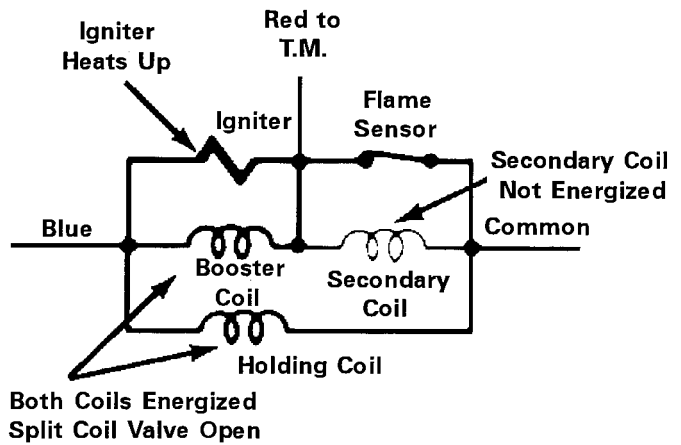

Normal Ignition

After about 30 seconds the igniter heats to about 1800 degrees F. and the flame sensor, reacting to the heat from the igniter, opens its contacts. When the flame sensor opens, the secondary coil energizes causing the secondary valve to open and allowing gas to flow to the burner. Part of the gas flow is directed over the hot igniter causing the gas to ignite. The heat from the main burner flame causes the flame sensor contacts to remain open (*see following figure*).

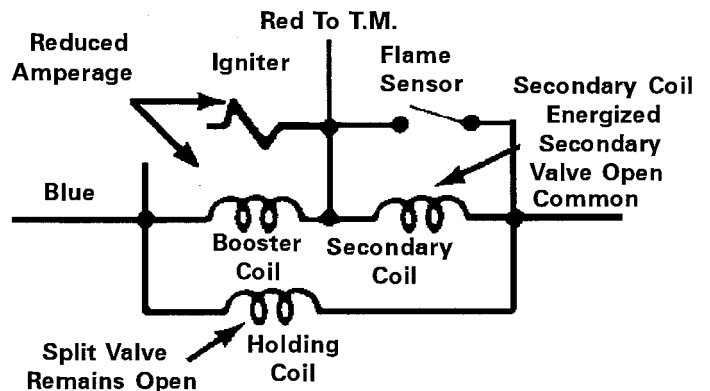

The introduction of the secondary coil into the circuit reduces the current flow

through the igniter and the booster coil from four amperes to about .1 amperes. The reduced current flow is not sufficient to operate either the igniter or the booster coil, but both components provide a path to complete the secondary coil circuit.

The burner assembly will continue to operate in this manner until the thermostat opens, breaking the circuit.

SAFETY FEATURES

The design of the system provides for safe operation in the event of power interruption, ignition failure or flame failure as described below:

Power Interruption

If the power to the burner assembly is cut off either by opening the dryer door or by line failure, both valves will close, cutting off the gas flow to the burner. If the power is quickly restored before the flame sensor cools and closes its contact, the secondary valve will open but no gas will flow because the split coil valve will not open. Since the secondary coil is in series with the booster coil, the reduced current flow through the booster coil cannot create a strong enough magnetic field to help the holding coil open the split coil valve (*see the following figure*). When the flame sensor cools and closes its contacts, it shunts the secondary coil providing a full current flow to the igniter and the booster coil, and the system will go through a normal ignition sequence.

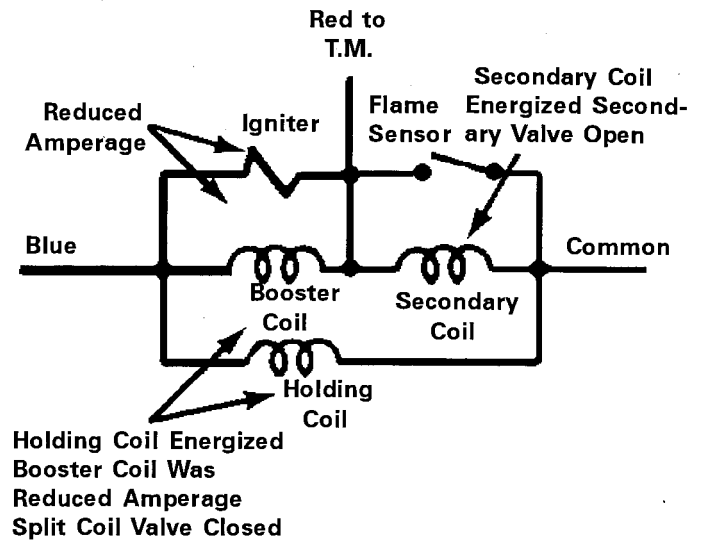

Ignition Failure

When the flame sensor reacts to the heat from the igniter and opens its contacts, the secondary coil energizes and opens the secondary valve enabling gas to flow to the burner. If no gas is present or the gas flow is not ignited, the flame sensor will cool and re-close its contacts causing the secondary valve to close and allowing the igniter to reheat. The system will continue to cycle in this manner until normal ignition occurs or the dryer is turned off (*see the following figure*).

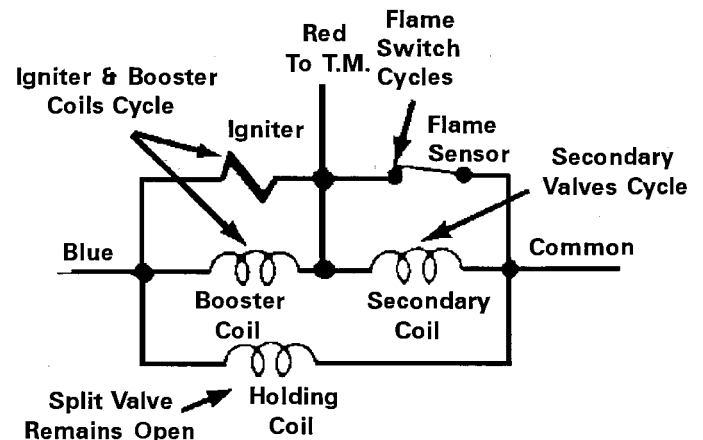

Flame Failure

If the burner flame should go out for any reason, the flame sensor will close its contacts in about 45 seconds, and the system will go through a normal ignition sequence.

PART REMOVAL AND REPLACEMENT

NOTE: *After reassembly, make sure all threaded sections are properly sealed and checked for leaks.*

Gas Control Valve And Burner Assembly

1. Disconnect the unit from the power source.
2. Remove the front panel.
3. Turn the shut off valve to the "OFF" position to stop the flow of gas to the control valve.
4. Loosen the large brass union nut located directly below the gas control valve.
5. Remove the screw which attaches the gas control valve and burner bracket assembly to the front roller support leg.
6. Lift up slightly on the front of the assembly to disengage the burner bracket tabs from the support leg.
7. Withdraw the assembly from the front.

Burner Assembly

1. Remove the gas control valve and burner assembly as previously described.
2. Remove the two (2) screws which secure the burner assembly and igniter bracket to the burner bracket.
3. Lift burner assembly off.

Burner Orifice

1. Remove the burner assembly as previously described.
2. Unscrew the burner orifice from the gas control valve.

Igniter Assembly

1. Remove the gas control valve and burner assembly as previously described.
2. Disconnect the plastic wiring block from the gas control valve to the igniter assembly.
3. Remove the screw which secures the igniter assembly to the igniter bracket.

The mounting bracket is designed to accurately position the igniter within the gas flow to ensure proper ignition.

Gas Control Valve

1. Remove the gas control valve and burner assembly as previously described.
2. Disconnect the plastic wiring blocks from the valve coils and remove the plastic wire clip.

3. Remove the burner assembly as previously described.
4. Remove the brass tail piece from the bottom of the gas valve by using a 3/8" hex wrench.
5. Remove the screw which secures the gas valve to the bracket.

Valve Coils

NOTE: *It is not necessary to remove the gas control valve and burner assembly to remove and replace valve coil(s)*

1. Disconnect the unit from the power source.
2. Remove the front panel.
3. Disconnect the plastic wiring blocks from the valve coil(s).
4. Remove the two (2) cross head screws which secure the coil cover and lift cover off.
5. Lift coil(s) off shaft.

Gas Pipe And Shut Off Valve Assembly

1. Disconnect the unit from the power source.
2. Shut off gas **to the gas inlet pipe.**
3. Disconnect the gas supply line from the gas inlet pipe.
4. Loosen the large brass union nut located directly below the gas control valve and withdraw the gas inlet pipe and shut off valve assembly.

5. The gas inlet pipe can be unscrewed from the shut off valve.

Flame Sensor

NOTE: *It is not necessary to remove the gas control valve and burner assembly to remove and replace the sensor.*

1. Disconnect the unit from the power source.
2. Remove the front panel.
3. Disconnect the sensor wiring.
4. Remove the screw on the left side of the heater housing which secures the sensor to the housing.
5. Disengage the sensor locating tab from the slot in the housing and lift out the sensor.

Heating Housing

1. Remove the gas control valve and burner assembly.
2. Remove the cylinder assembly.
3. Remove the two (2) screws inside the front of the housing which attach the housing to the support.
4. Disengage the housing rear tabs from the inlet duct and remove the housing.

BULKHEAD ASSEMBLY

The bulkhead assembly is mounted to the inner cabinet rear and is comprised of a primed steel bulkhead with the following components attached to it.

Inlet Duct (Gas Model) or Heater Housing (Electric)

These galvanized steel components mount to the rear of the bulkhead and contain perforations which channel the flow of heated air into the cylinder rear.

The heater housing used on the electric model is located on the upper left rear of the bulkhead. It provides mounting for the heater element assembly.

Gas models are equipped with a long inlet duct which extends downward and connects to the burner housing.

To replace either the inlet duct or heater housing, the bulkhead assembly should be removed as detailed later in this subsection.

NOTE: *This does not apply to replacement of the heater element which is covered in the following subsection.*

High Limit Thermostat

The high limit thermostat is located on top of the heat inlet duct of gas models and on a bracket which mounts to the top of the bulkhead on electric models. The thermostat is secured by two (2) screws which can be accessed by raising the top assembly.

Thermal Fuse

A non-resetting thermal fuse is located on top of the heat inlet duct on gas models and on the side of the heater housing on electric models. The thermal fuse is secured by two (2) screws on gas models and by the heater element assembly screw on the electric models.

Cylinder Light Lens

The cylinder light lens is secured to the rear of the bulkhead by two (2) spring clips. The lens can be accessed for replacement by removing the front panel and cylinder assembly.

Terminal Block (Electric Model)

The terminal block is attached to the right side of the bulkhead by two (2) locknuts which thread over two (2) screws which are ***permanently*** affixed to the bulkhead. The locknuts are located directly above and below the center wiring stud (neutral) on the block and can be accessed from the rear of the machine after the supply cord cover plate has been removed. Removal of these locknuts will allow removal of the terminal block.

Rear Seal

The rear seal is glued to the outer perimeter of the bulkhead assembly.

NOTE: *Seal replacement is detailed in Section 4.*

Rear Support Rollers

The rear support rollers are mounted on the lower corners of the bulkhead assembly.

NOTE: *Support roller replacement is detailed in Section 4.*

BULKHEAD ASSEMBLY REMOVAL

NOTE: *It is necessary to remove the bulkhead assembly only when replacing the inlet duct, heater housing (not the element) or the bulkhead itself.*

1. **Disconnect the unit from the power source.**
2. Remove the front panel and cylinder assembly.
3. Disconnect the high limit thermostat wiring (both models) and the heater wiring (electric models only).
4. From the outer cabinet rear, remove the eight (8) slotted head screws which secure the assembly. Lift the assembly from the cabinet.
5. The inlet duct or heater assembly can be separated from the bulkhead by removing the two (2) cross head screws next to the perforations one (1) screw on the upper left under the seal and the two (2) at the bottom of the bulkhead (gas models only).

SECTION 7. BACKGUARD ASSEMBLY

A typical backguard assembly, as illustrated on the following page, consists of the control panel, knobs, end caps, control shield, backguard shield, timer switches and buzzer.

The backguard assembly is secured to the top panel by screws which pass upward through the bottom of the top panel and thread into end caps. The assembly is further retained and supported at the rear by the backguard shield which is attached to the control panel, end caps and top flange.

The control is attached to the end caps at the bottom front and top rear corners. The control shield which provides the mounting for all controls is also attached to the end caps.

DISASSEMBLY

Before attempting to gain access to the controls mounted within the background assembly, place a protective cloth or pad on the cabinet top in front of the control panel to prevent scratches.

1. **Disconnect the unit from the power source.**
2. Remove the selector and timer knobs by pulling straight off.
3. Remove the three (3) cross head screws which secure the rear top edge of the control panel to the caps and backguard shield.
4. Remove the two horizontal cross head screws which secure the bottom front corners of the control panel to the end caps.
5. Remove the screws which secure the control shield to the wrapper and lay the front of the control shield on the protective cloth. The backguard components are now accessible for testing and/or replacement.

NOTE: *The procedure for testing the backguard components are described in Section 8.*

BACKGUARD ASSEMBLY

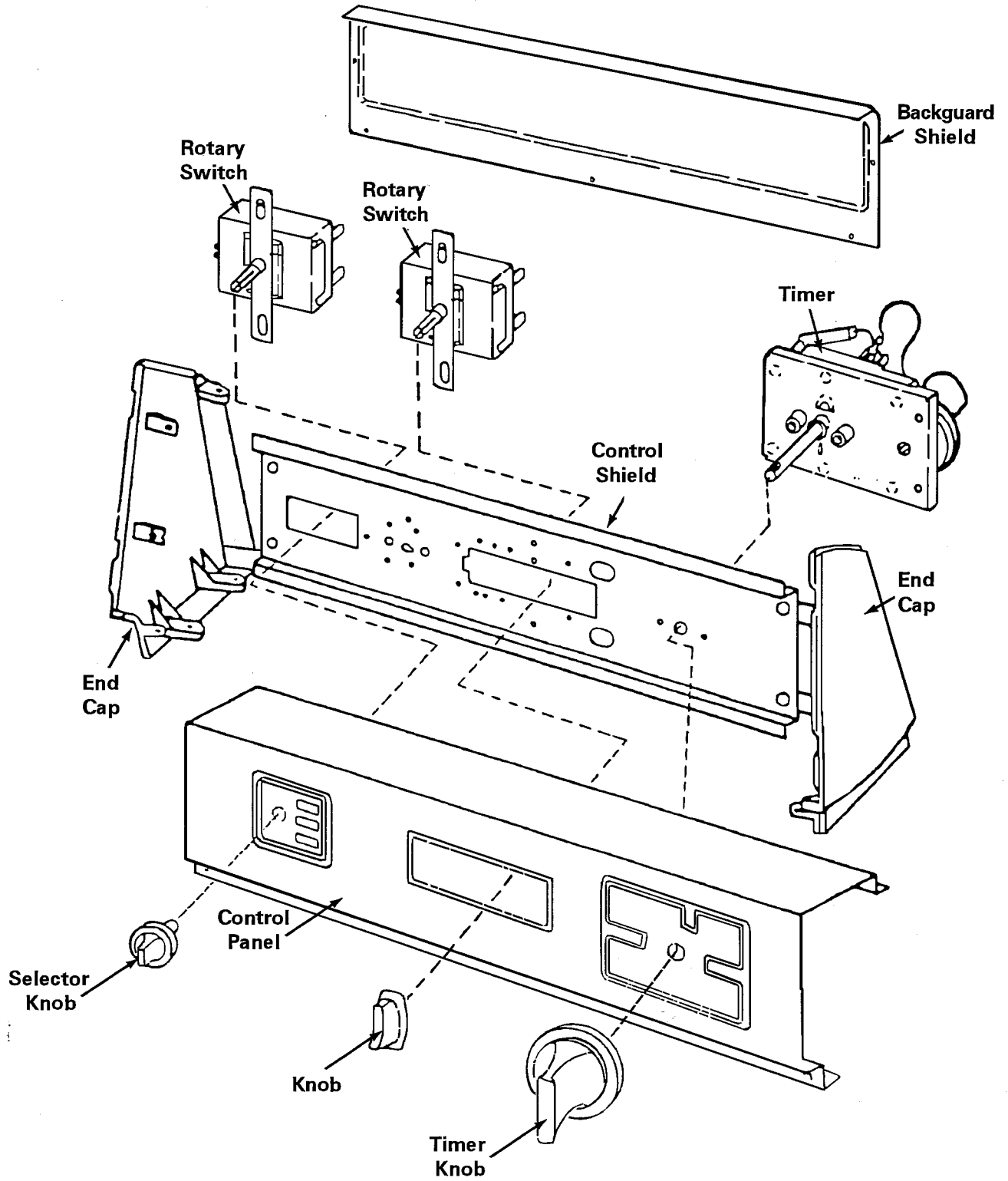

SECTION 8. ELECTRICAL COMPONENTS AND TESTING

TIMER

The timer is an incremental advance, rotary type and is driven by a 110V synchronous motor.

The timer controls and sequences the functions involved in each dry cycle by providing, or denying power to the various electrical components. This is accomplished by opening and/or closing action of the timer contacts.

The timer has a built-in "**Push to Start**" switch that is activated by depressing the timer knob. This switch is a safety feature that completes the motor start circuit. The dryer motor will not start in any segment of any cycle unless the "**Push to Start**" switch is closed.

Resistor (Electric Models Only)

The timer on the electric model has a resistor installed on it as part of the timer motor circuit. The resistor is installed during manufacturing and is **not** on replacement timers. If a timer is replaced, be sure to remove the resistor from the old timer and install it on the new one.

TIMER ACCESS AND/OR REMOVAL

Timer access and/or removal is detailed in **Section 7, under Backguard Disassembly.**

Timer Sequence Chart

A combination timer sequence chart, switch position charts, schematic diagram and other pertinent information is placed in the backguard assembly.

The following two figures, electric models and gas models, typically illustrate a condensed version of the schematic information supplied with each unit.

Listed down the left side of the sequence chart are the terminal contacts which control dryer functions. The top of the chart indicates the different dry cycles and their off positions. The dark lines denote when the contacts are closed during a particular dry cycle. The numbers at the bottom of the chart indicate the length of time the contacts are closed with the timer motor energized.

Contact Functions

Contacts T-M provide power to the buzzer. These contacts are closed approximately 5 seconds, every 5 minutes during the "**Cool Down**" or "**Wrinkle Release**" phase of the cycles. This produces the intermittent end of cycle buzz.

Contacts L-H provide power to the heat source at the beginning of each dry cycle. They remain closed until the "**Cool Down**" phase.

Contacts TM-A close at the beginning of the "**Automatic Dry**" cycles only. It sets up the timer motor circuit as a parallel circuit to the heat control circuit.

When the heat circuit is closed the timer motor is shunted.

Contacts L-W close the last 5 minutes of the "**Automatic Permanent Press**" cycle. They provide power to the drive motor through the wrinkle control switch if "**Wrinkle Release**" was selected.

Contacts TM-N close at the beginning of the "**Timed Dry**" cycle only. They provide power to the timer motor throughout the cycle.

Contacts L-M provide power to the motor circuit. They are closed at the beginning of each dry cycle and remain closed throughout the cycle except during the "**Wrinkle Release**" phase of the "**Automatic Permanent Press**" cycle.

Contacts M-S are the "**Push to Start**" contacts. They provide power to the motor start circuit when the timer knob is depressed and contacts **L-M** are closed.

TESTING

The timer can be tested by using an ohmmeter and the timer sequence chart as detailed below:

EXAMPLE:

To test the operation of the heat source contacts (identified as **L-H** in **Contact Functions**), refer to the left side of the sequence chart and observe the dart line opposite terminals **L-H**. The chart indicates that contacts **L-H** close at the beginning of each cycle and remain closed until the "**Cool Down**" phase. This action can be verified by connecting the ohmmeter leads between timer contacts **L-H** and checking continuity as the timer is manually advanced.

WRINKLE RELEASE SWITCH

The "**Wrinkle Release**" selector switch is a two (2) position switch which is a rotary type. Its function is to provide a circuit around open timer contacts for the "**Wrinkle Release**" operation. The circuitry of the dryers equipped with "**Wrinkle Release**" switch is designed so that the feature is available only at the end of the "**Automatic Permanent Press**" cycle.

SWITCH ACCESS AND/OR REMOVAL

The "**Wrinkle Release**" switch can be accessed and/or removed as detailed in **Section 7** under **Backguard Disassembly**.

TESTING

Using an ohmmeter, check between terminals **B2-B4** with the switch in the "**ON**" position. Continuity should be indicated.

TEMPERATURE SELECTOR SWITCH

Temperature selector switches are three (3) position and are the rotary type. The position of the switch determines which circuit of the thermostat, low or high, will control the heat circuit.

NOTE: *The "Fluff" position opens the heat circuit altogether.*

WIRING DIAGRAM (ELECTRICAL MODEL)

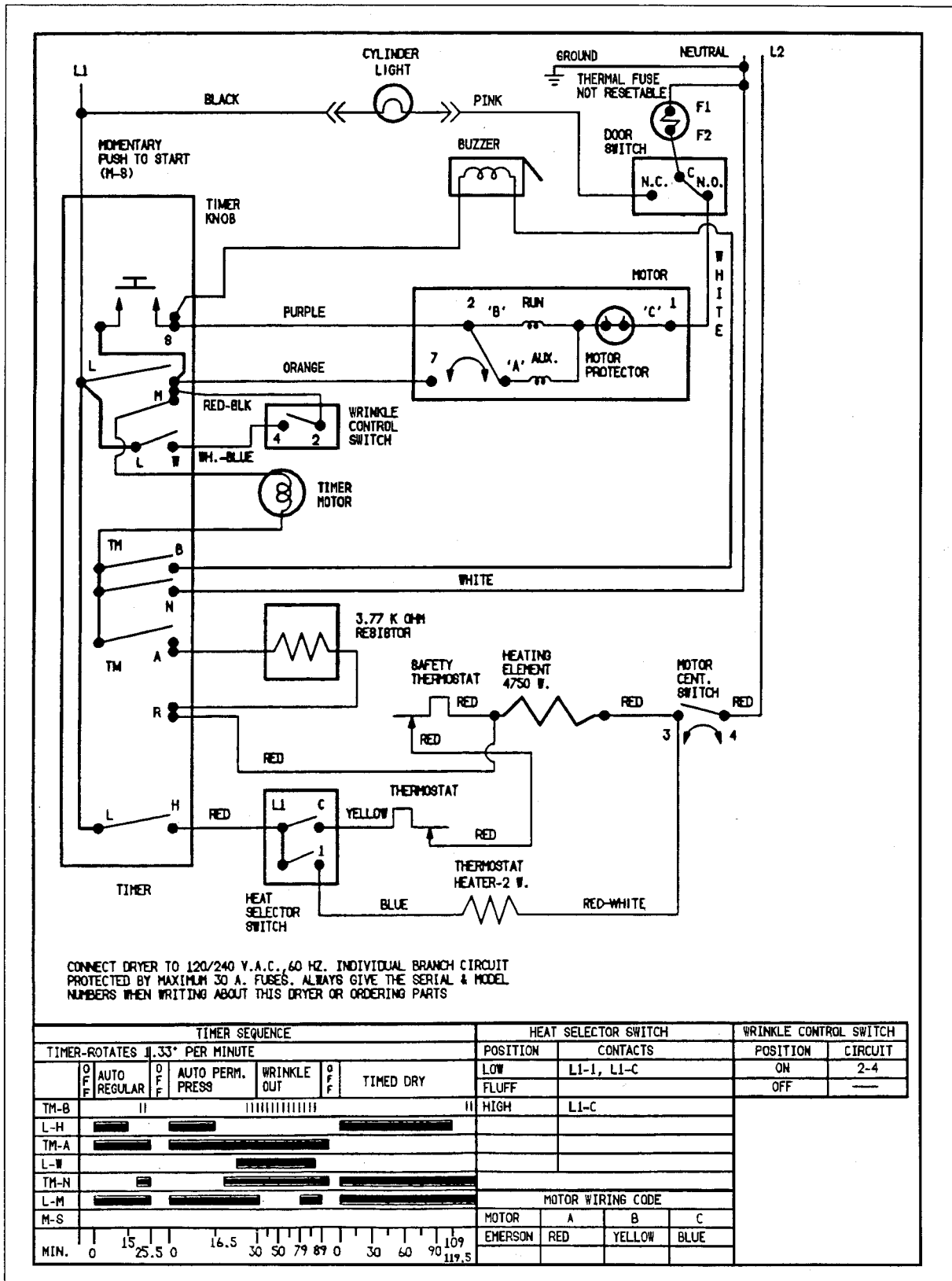

WIRING DIAGRAM (ELECTRICAL MODEL)

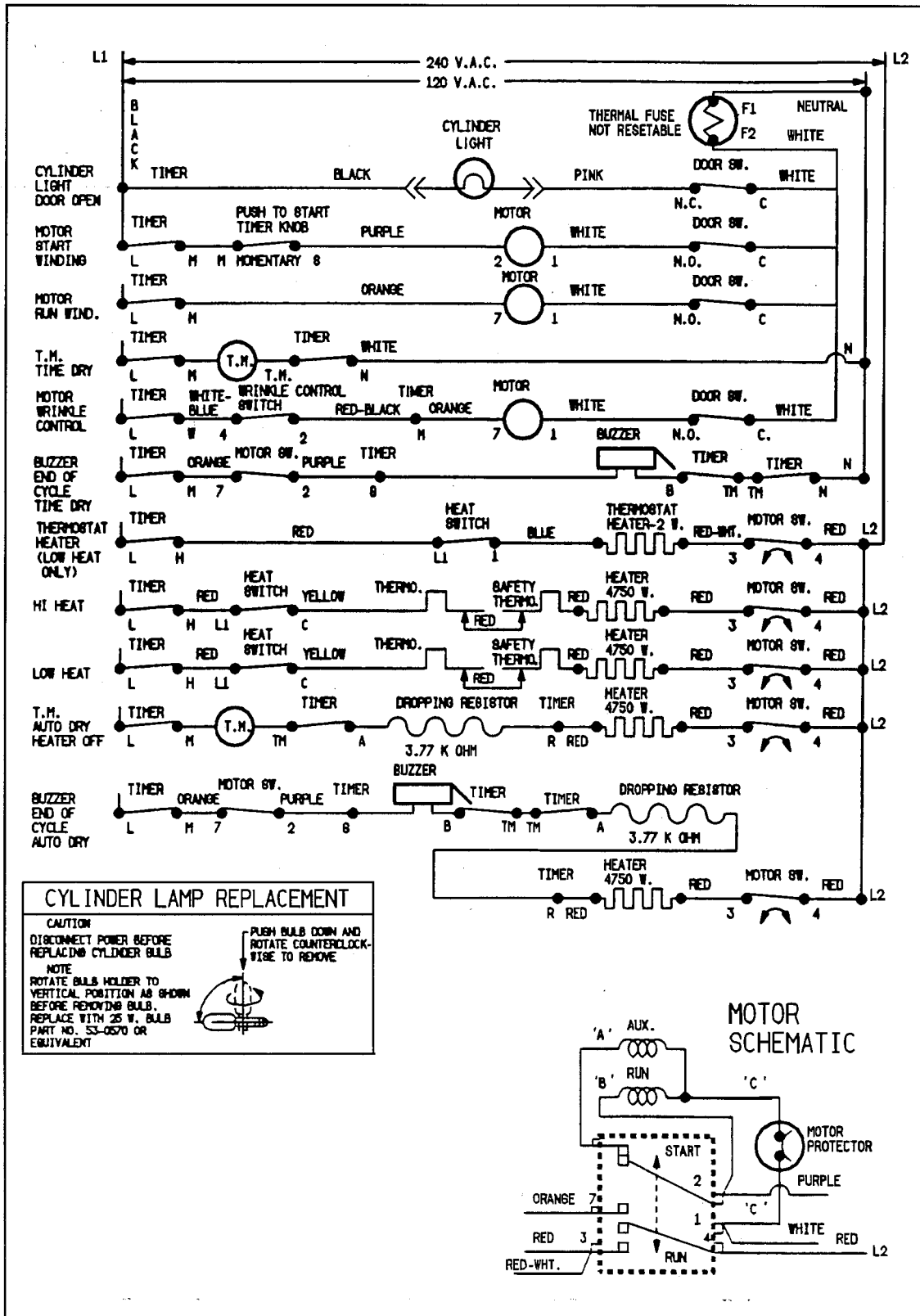

WIRING DIAGRAM (GAS MODEL)

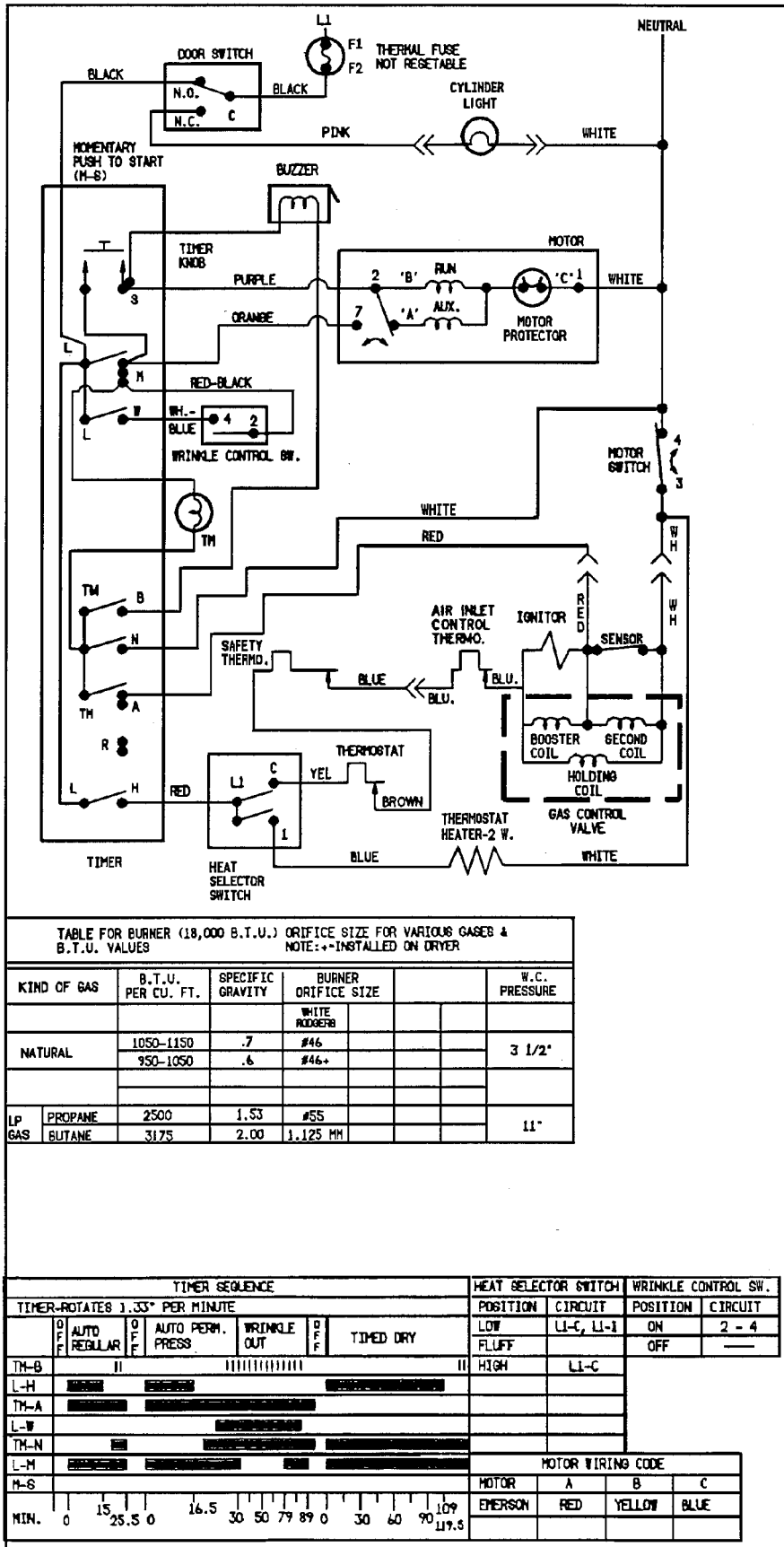
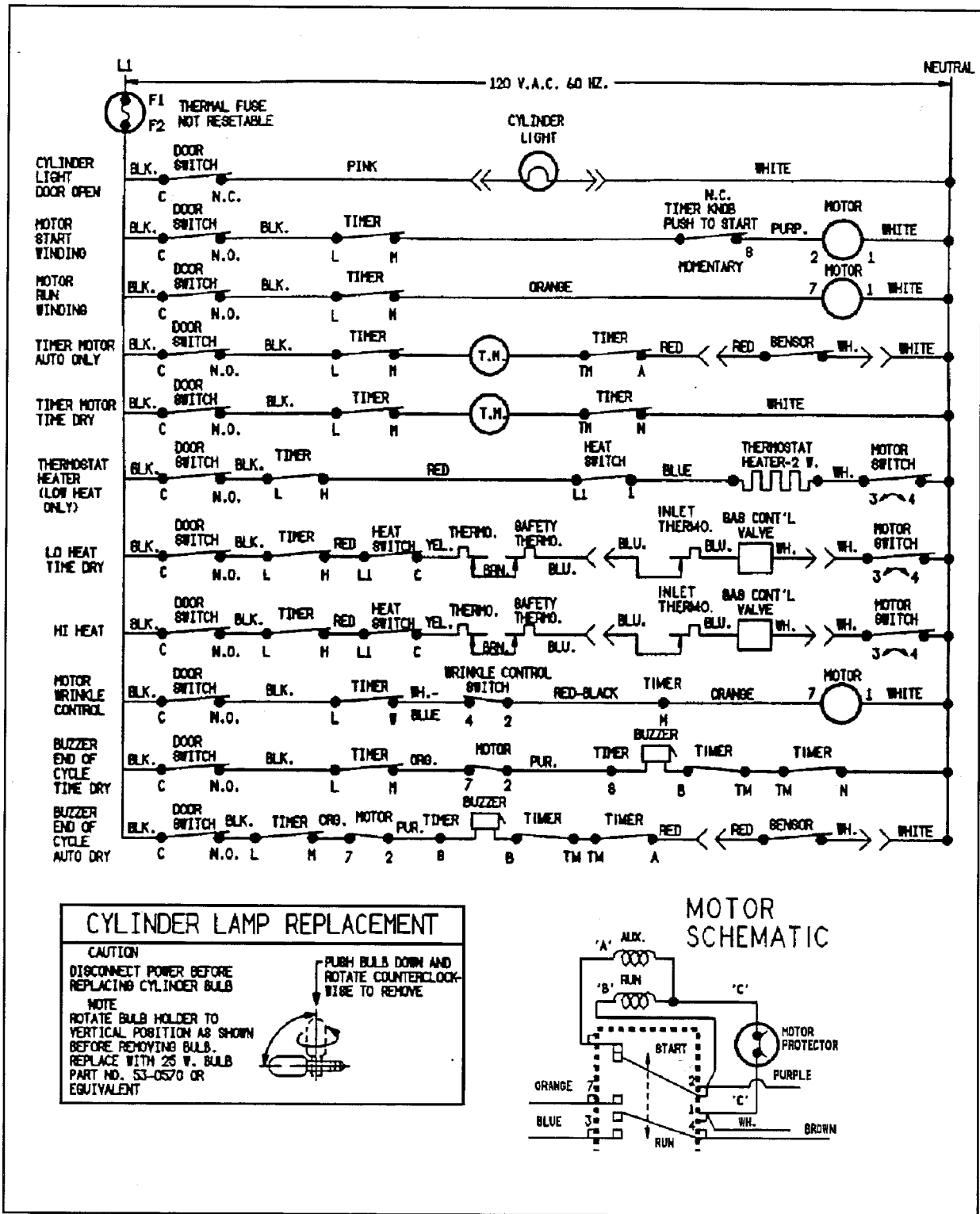

TABLE FOR BURNER (18,000 B.T.U.) ORIFICE SIZE FOR VARIOUS GASES & B.T.U. VALUES
NOTE: + - INSTALLED ON DRYER

KIND OF GAS	B.T.U. PER CU. FT.	SPECIFIC GRAVITY	BURNER ORIFICE SIZE	W.C. PRESSURE
NATURAL	1050-1150	.7	#46	3 1/2"
	950-1050	.6	#46+	
LP GAS	PROPANE	2500	1.53	11"
	BUTANE	3175	2.00	

TIMER SEQUENCE						HEAT SELECTOR SWITCH		WRINKLE CONTROL SW.	
	O F F	AUTO REGULAR	AUTO PERM. PRESS.	WRINKLE OUT	O F F	POSITION	CIRCUIT	POSITION	CIRCUIT
						LOW	LI-C, LI-1	ON	2 - 4
						FLUFF		OFF	
TM-B						HIGH	LI-C		
L-H									
TM-A									
L-W									
TM-N									
L-M									
M-S						MOTOR WIRING CODE			
						MOTOR	A	B	C
						EMERSON	RED	YELLOW	BLUE

WIRING DIAGRAM (GAS MODEL)



SWITCH ACCESS AND/OR REMOVAL

The thermostat selector switch can be accessed and/or removed as detailed in *Section 7 under Backguard Disassembly*.

TESTING

Using an ohmmeter, check for continuity between terminals **L1-1** with the switch in the **DELICATE** position, and the **L1-C** in the **REGULAR** positions.

DOOR SWITCH

The door switch is located inside the door well on the upper right. It is attached to the inside of the front panel by a clip. The switch can be removed by spreading the arms of the clip and withdrawing the switch from the inside of the front panel.

Models are equipped with a cylinder light and use a normally closed, single-pole, double-throw type switch. One contact completes the motor circuit when the door is closed, and the second contact completes the light circuit when the door is open.

TESTING

The door switch can be tested in place by using an ohmmeter and performing the following:

1. **Disconnect the unit from the power source.**
2. Disconnect switch wiring.
3. Check between the switch terminals for continuity.

- No continuity should be indicated between terminals **COM** and **NO** until the switch is activated.
- On double-throw switches, continuity should be indicated between **COM** and **NC** until the switch is activated.

SILICON CARBIDE IGNITION SYSTEM

The failure of a component in this system will usually be indicated by one of three symptoms:

- The igniter does not glow.
- The igniter glows but no gas ignition takes place.
- The gas is ignited but the flame goes out.

The following test procedures are to assist in determining which components is causing the problem.

NOTE: *In all failures it is suggested that the burner assembly be isolated from the dryer circuitry for testing.*

1. **Disconnect the dryer from its power source.**
2. Disconnect the three (3) wire plug from the harness to the burner assembly. Check the wiring diagram and connect a test cord to the proper burner assembly wires.

When power is applied, the operation of the burner assembly can be observed. This procedure eliminates the possibility of a defective component in the dryer affecting the burner test.

CAUTION

When testing the burner in this manner, do not allow the flame to burn any longer than is required for the test in order to avoid excessive heat buildup in the heater housing and inlet duct.

No Igniter Glow

If the igniter does not heat up, remove power, and using an ohmmeter check the following:

- Open Flame Sensor
- Open Igniter
- Open Booster Coil
- Open Wiring

Igniter Glows - No Gas Ignition

If the igniter heats up but the main burner flame is not ignited, remove power and using an ohmmeter check the following:

- Open Secondary Coil
- Open Holding Coil
- Open Wire

Other possible causes that will not show up in a continuity check but should be examined:

- Gas Valve Needs Replacement
- Restriction in the Burner Orifice
- Igniter Improperly Installed

Gas Ignites - Flame Goes Out

If a normal ignition takes place and after a short while the flame goes out, check for the following:

- Erratic Flame Sensor

16023116

HEATER ELEMENT ASSEMBLY

The heater element assembly mounts within the heater housing which is located behind the bulkhead on the upper left.

NOTE: *Removal of the heater element assembly is detailed in Section 6.*

The heater element assembly is serviced as a completely assembled unit, ready to mount in the heater housing.

ELEMENT SPECIFICATIONS

The heater element is rated at 4750 watts at 240V. It has an approximate cold ohm resistance of 10.94.

BIAS-HEATED THERMOSTATS

The bias-heated thermostat mounts to the blower cover and responds to the temperature of the air after it has passed over the clothes load. The heated thermostat has an operating temperature of approximately 146 degrees F. The bias-heated thermostat is equipped with an ***internal resistor*** which provides for a low temperature setting of approximately 131 degrees F.

OPERATION

HIGH HEAT SELECTED: When the temperature of the air passing over the clothes load reaches approximately 146 degrees F, the thermostat disc will actuate and open the circuit to the heat source.

LOW HEAT SELECTED: When low heat is selected, the thermostat internal resistor is placed in the circuit and ***preheats***

the thermostat disc to approximately 15 degrees F. the air now passing over the clothes load will only need to reach 131 degrees F. before the thermostat disc actuates and opens the circuit to the heat source.

Control Thermostat

The control thermostat is mounted to the blower housing cover and responds to the temperature of the air after it passes over the clothes load. The operating temperatures are 140 degrees F. for **REGULAR** and 120 degrees F. for the **DELICATE**.

REMOVAL

1. Disconnect the unit from the power source.
2. Remove the front panel.
3. Disconnect the thermostat wiring.
4. Remove the screws which secure the thermostat to the blower cover.

High Limit Thermostat

The high limit thermostat is located on top of the heat inlet duct on gas models, and on a bracket which mounts to the top of the bulkhead on electric models. The thermostat is secured by two (2) screws which can be accessed by raising the top assembly.

The high limit thermostat responds to the temperature of the air before it is drawn over the clothes load, and is located to sense heat buildup during a possible air flow interruption.

The operating temperature of the high limit thermostat is 240 degrees F. on the gas model and 250 degrees F. on the electric model.

Inlet Air Control Thermostat (Gas Models Only)

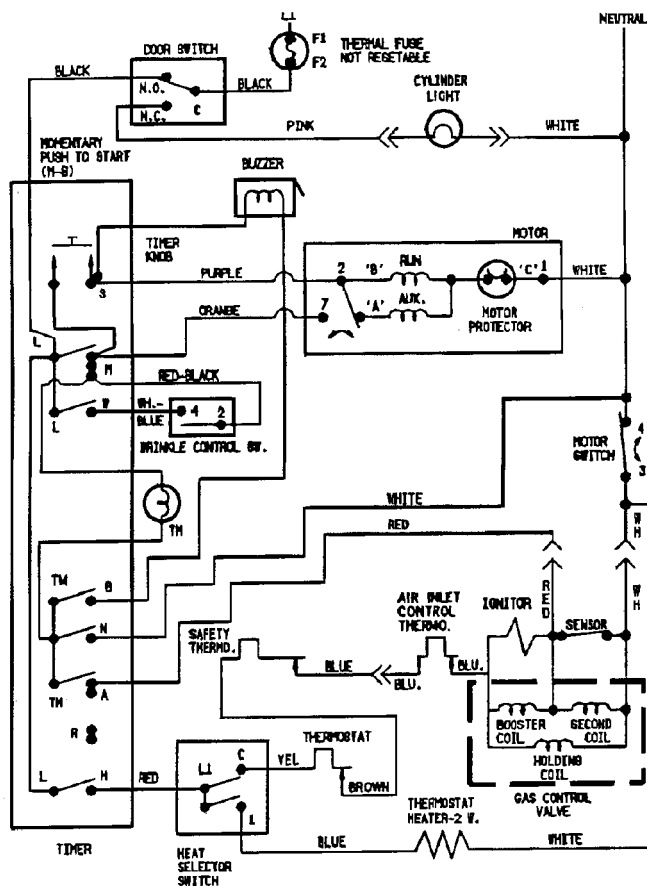

All gas dryers are equipped with an inlet air control thermostat. The inlet air control thermostat is the same as the high limit thermostat.

This additional thermostat is located on the upper front end of the heater housing above the burner, and will ensure a positive inlet air flow into the burner chamber. Should a situation occur which would prevent a positive air flow into the burner chamber, the heat rise would cause the thermostat to open. This would open the circuit to the gas valve and shut off the heat (*see above schematic*).

TESTING THERMOSTATS

A thermostat failure usually occurs because the contacts fail to open at the proper temperature, or close when the thermostat cools down.

To test for an open thermostat, turn the dryer on during the heat portion of any dry cycle.

NOTE: Make sure the fluff setting has not been selected.

If the heat source is energized, none of the thermostats are open (unless high heat selection has been made and the low temperature control thermostat is satisfied).

If the heat source is **not** energized, each thermostat must be tested between the terminals for continuity. Replace any thermostat that does not indicate continuity.

If the control thermostat is suspected of not opening at the proper temperature, place a thermocouple type thermometer down in the lint filter opening. With the cylinder empty, run the dryer during the heat portion of any dry cycle and monitor the temperature. If the temperature stays between 105-125 degrees F. on **DELICATE** setting or 110-145 degrees F. on **REGULAR** setting, the thermostat is operating properly.

The high limit thermostat can be tested by restricting the exhaust vent. A complete blockage of the vent will result in sufficient heat buildup to cause the high limit thermostat to open its contacts in a few minutes.

THERMAL FUSE

In order to comply with applicable U.L. standards, all dryers are now being equipped with a non-resetting thermal fuse as an additional safeguard.

The fuse is assembled to the side of the heater housing on electric models, and on the top of the inlet duct on gas model dryers. The same thermal fuse is used on both models.

The one time fuse is set to open at approximately 300 degrees F. and is wired in series with the door switch. Should a malfunction occur and an abnormal heat rise cause the thermal fuse to open, this will open the circuit to the drive motor, centrifugal switch and heat source, thus stopping dryer operation (*see the following schematic*).

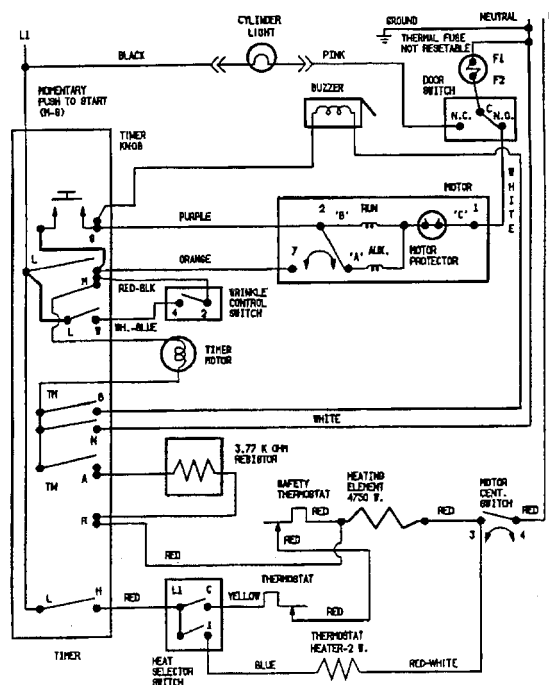

After correcting the dryer malfunction which caused the thermal fuse to open, **be sure to replace the high limit thermostat as well as the thermal fuse.** This is necessary since the high limit thermostat

is designed to open at a lower temperature than the thermal fuse, and failed to do so.

NOTE: *As an additional precaution, check the total exhaust system (lint filter, vent duct, etc.) for lint buildup and clean as necessary.*

MOTOR

The motor used on both the gas and electric model dryers is a 1/4 H.P., split phase, overload protected type. It has an externally mounted motor switch which can be replaced.

Overload Protector Switch

The protector switch is wired in series with the motor, and its contacts are normally closed. The contacts of the protector switch open in response to a temperature rise, an excessive amperage draw or a combination of both. The contacts reset automatically when they cool down.

If the protector switch contacts open, the motor circuit is broken. The motor stops and the motor switch contacts open which break the heating circuit.

Motor Switch

The motor switch has two (2) sets of contacts; one to control the motor circuit and the other to control the heat circuit. When the motor is at rest, the motor control contacts are closed, completing a circuit to the start winding, and the heat circuit contacts are open.

When the motor starts running, a centrifugal arrangement activates a holding

lever which allows both sets of contacts to move simultaneously. The motor control switch opens the start circuit and closes a circuit to the run winding. The heat circuit contacts close to complete the circuit to the heat source.

The motor switch is mounted to the motor by two (2) slot head screws and can be removed accordingly.

NOTE: *If the switch is to be removed, be sure to note the mounting position of the internal wires on the switch.*

MOTOR REMOVAL

1. Disconnect the unit from the power source.
2. Remove the front panel and cylinder assembly.
3. Remove the blower cover assembly from the housing.
4. Remove the blower wheel from the motor shaft.
5. Disconnect the motor ground wire and harness wires.
6. Remove the spring clip motor clamp. Rotate the motor frame to unlock it from the blower housing rear.

MOTOR TESTING

The motor, overload protector switch and the motor switch are components that must function correctly in order for the motor to run. To determine the cause of a motor not operating properly, it is necessary to isolate the motor and its two (2) related components from the rest of the machine circuitry.

The following service test procedure is suggested to facilitate locating a failed component in the motor circuitry:

1. Remove all wiring harness connections to the motor switch. ***Do not*** disconnect the wires that come from inside the motor.
2. Connect a test cord to terminals 1 and 2 and plug the test cord into an outlet. If the ***motor*** runs, the problem is in the wiring or a control. If it does not run, continue the test procedure.

NOTE: *The following tests should be made with a continuity tester such as an ohmmeter, and the power to the machine should be disconnected.*

3. To test the continuity of the ***overload protector switch***, connect the test leads to motor switch terminals 1 and 2. Continuity should be indicated.

4. If the protector switch checks out to be functioning properly, but the switch opens repeatedly in normal operation, check the following:

- A binding condition in the motor or cylinder drive system.
- Poor electrical connections causing a low voltage condition.
- Motor overheating because of a restricted cooling air flow.

5. To test the ***motor switch*** in its start position, the ohmmeter should indicate an open circuit between terminals 2-7 and 3-4 (*see the following figure*).

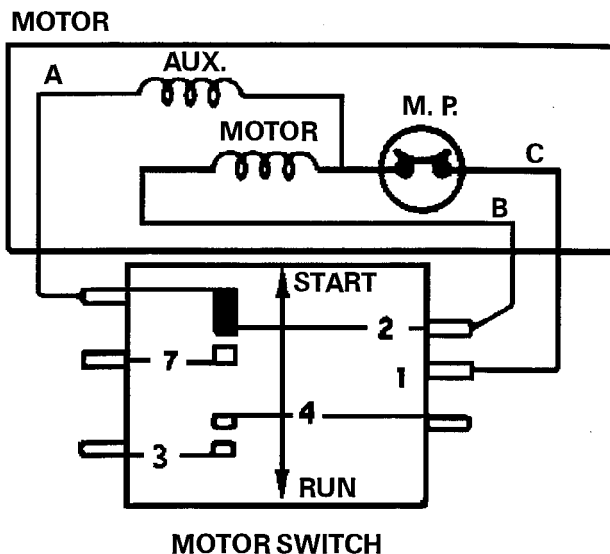

MOTOR SWITCH (START)

When the motor switch is in its run position (lever activated), its contacts close and continuity should be indicated between terminals 2-7, the motor run circuit and terminals 3-4, the heat circuit (*see the following figure*).

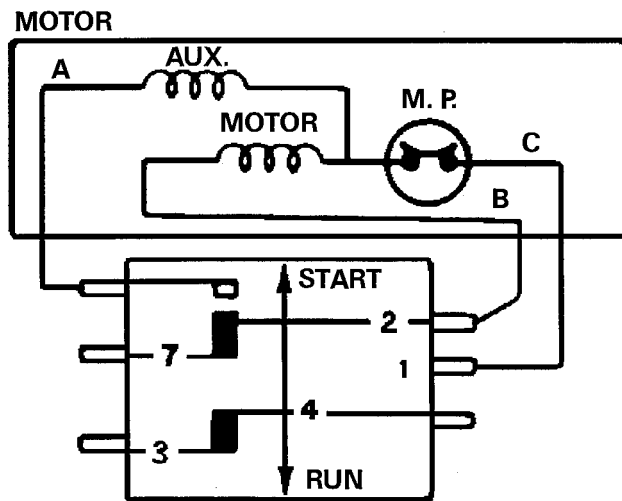

MOTOR SWITCH (RUN)

SECTION 9. WIRING INFORMATION

DLE231 L1

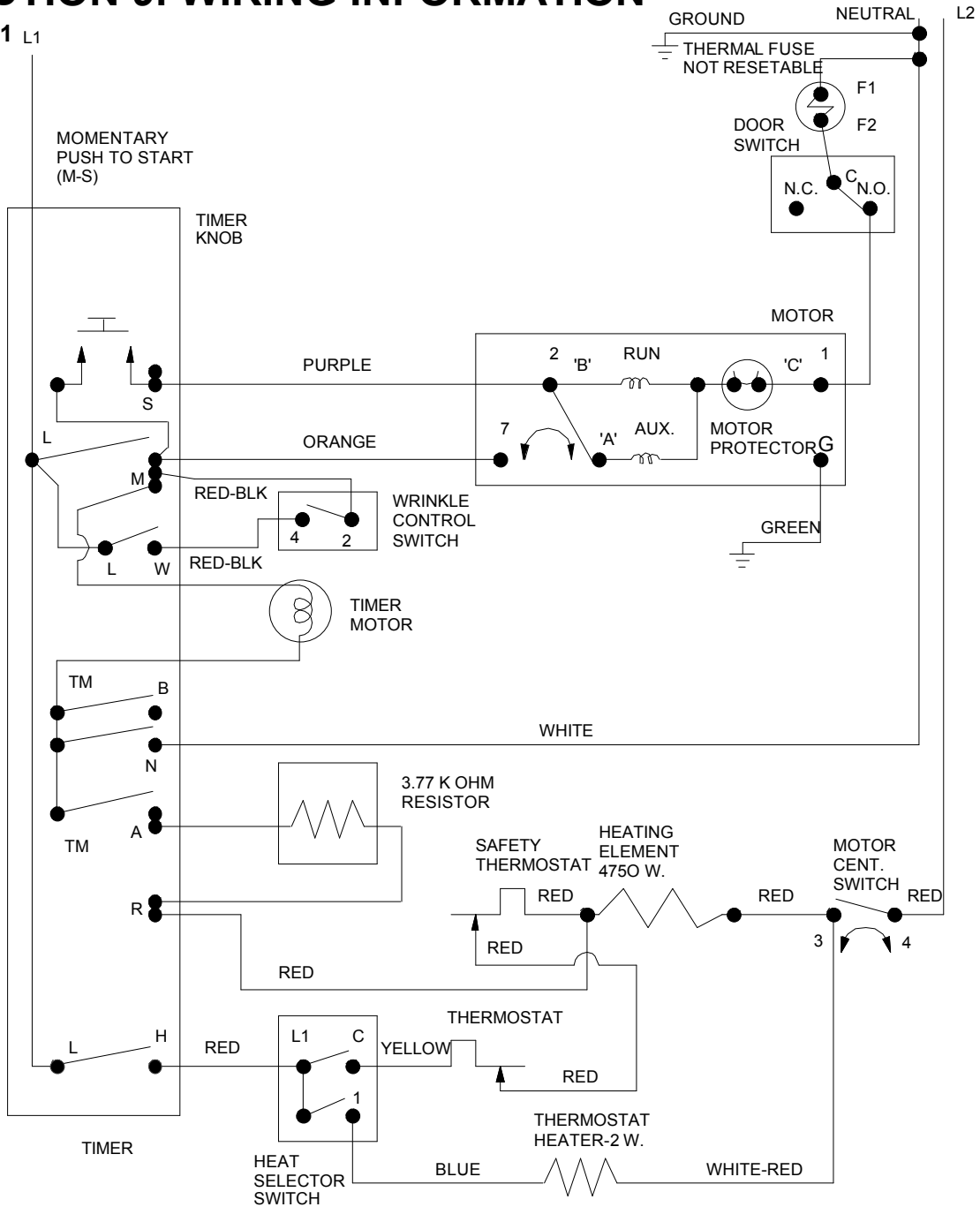

CONNECT DRYER TO 120/240 V.A.C., 60 H.Z. INDIVIDUAL BRANCH CIRCUIT PROTECTED BY MAXIMUM 30 A. FUSES. ALWAYS GIVE THE SERIAL & MODEL NUMBERS WHEN WRITING ABOUT THIS DRYER OR ORDERING PARTS

TIMER SEQUENCE						HEAT SELECTOR SWITCH		WRINKLE CONTROL SWITCH							
TIMER-ROTATES 1.33 PER MINUTE						POSITION	CONTACTS	POSITION	CIRCUIT						
	OFF	AUTO REGULAR	OFF	AUTO PERM. PRESS	WRINKLE OUT	OFF	TIMED DRY	ON	2-4						
	F		F		F			OFF	—						
TM-B						LOW	L1-1, L1-C	OFF							
L-H						HIGH	L1-C								
TM-A															
L-W															
TM-N															
L-M															
M-S															
							MOTOR WIRING CODE								
							MOTOR	A	B	C					
							EMERSON	RED	YELLOW	BLUE					
MIN.	0	15	25.5	0	16.5	30	50	79	89	0	30	60	90	109	119.5

WIRING INFORMATION

DLE231

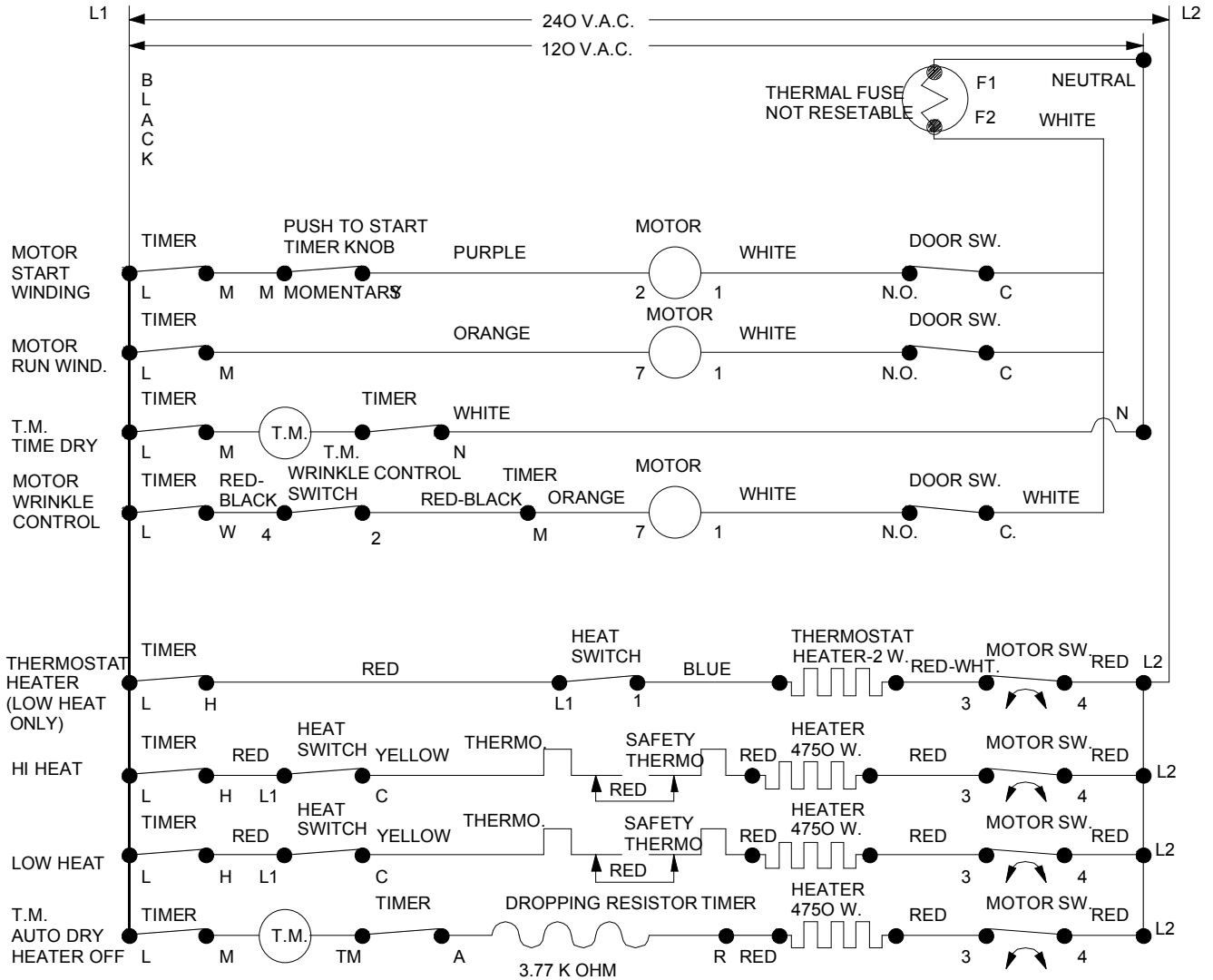

53-3768 "REL"

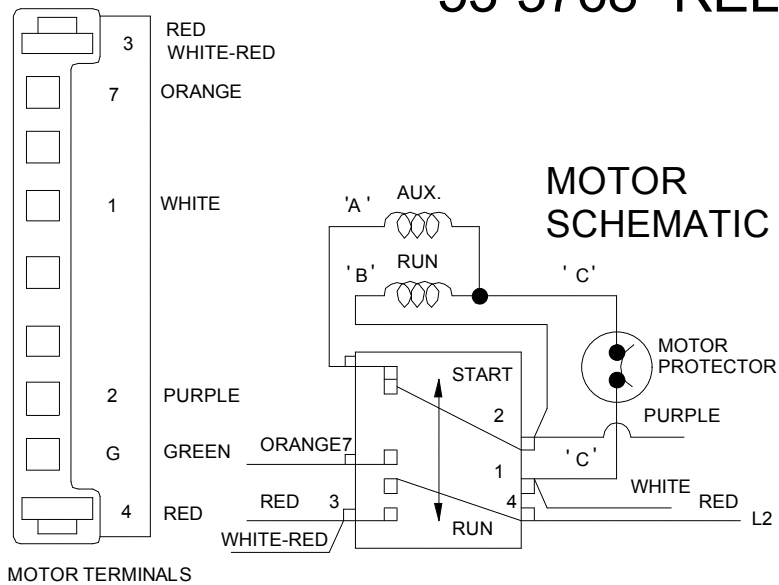

WIRING INFORMATION

DLG231

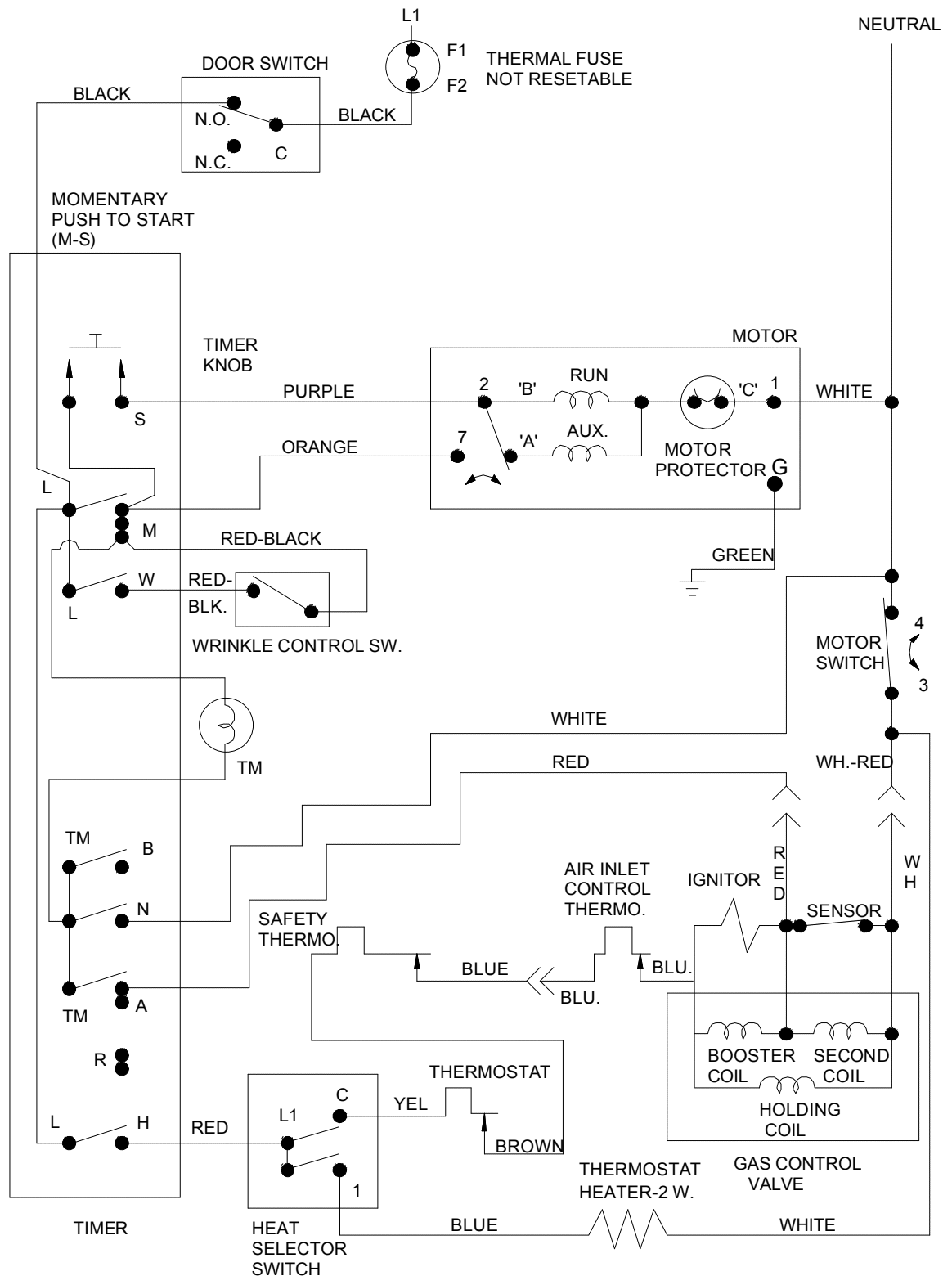

Caution: Label all wires prior to disconnection when servicing controls. Wiring error can cause improper and dangerous operation. Verify proper operation after servicing.

TIMER SEQUENCE						HEAT SELECTOR SWITCH		WRINKLE CONTROL SW.	
TIMER-ROTATES 1.33 PER MINUTE						POSITION	CIRCUIT	POSITION	CIRCUIT
	O F F	AUTO REGULAR	O F F	AUTO PERM. PRESS	WRINKLE OUT	FLUFF	LOW	ON	2-4
TM-B						HIGH	L1-C		
L-H	■	■	■	■	■				
TM-A		■		■	■				
L-W				■	■				
TM-N		■		■	■				
L-M	■	■	■	■	■				
M-S									
						MOTOR WIRING CODE			
						MOTOR	A	B	C
						EMERSON	RED	YELLOW	BLUE

WIRING INFORMATION

DLG231

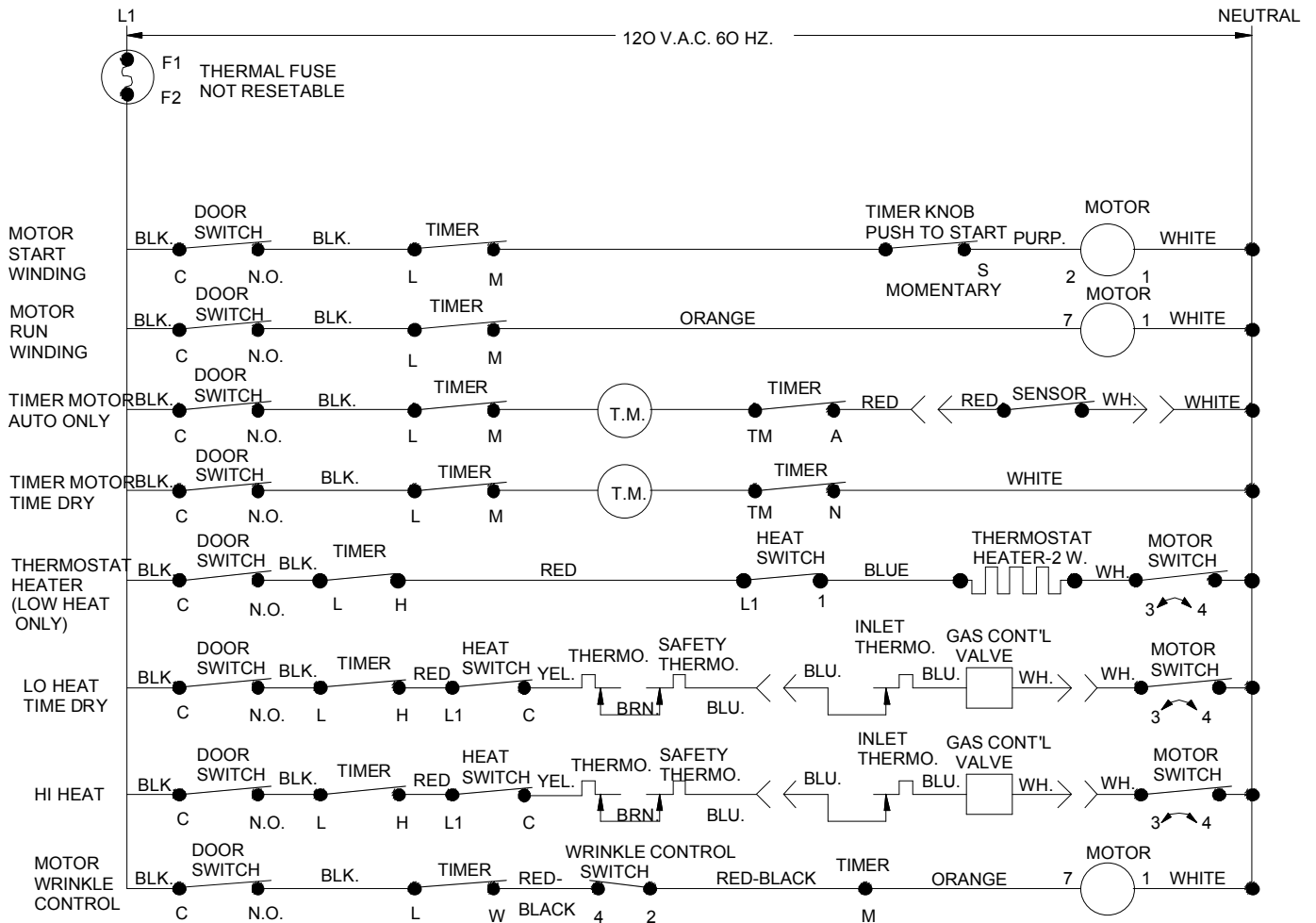

53-3767 "REL"

MOTOR TERMINALS

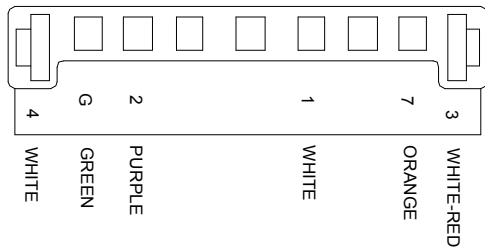

NOTICE:
CONNECT GROUND WIRE SECURELY
DO NOT GROUND TO GAS PIPE.

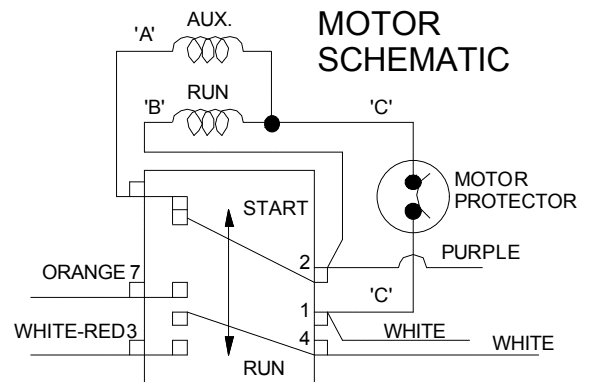

WIRING INFORMATION

PYE2300, HYE2460, PYET244

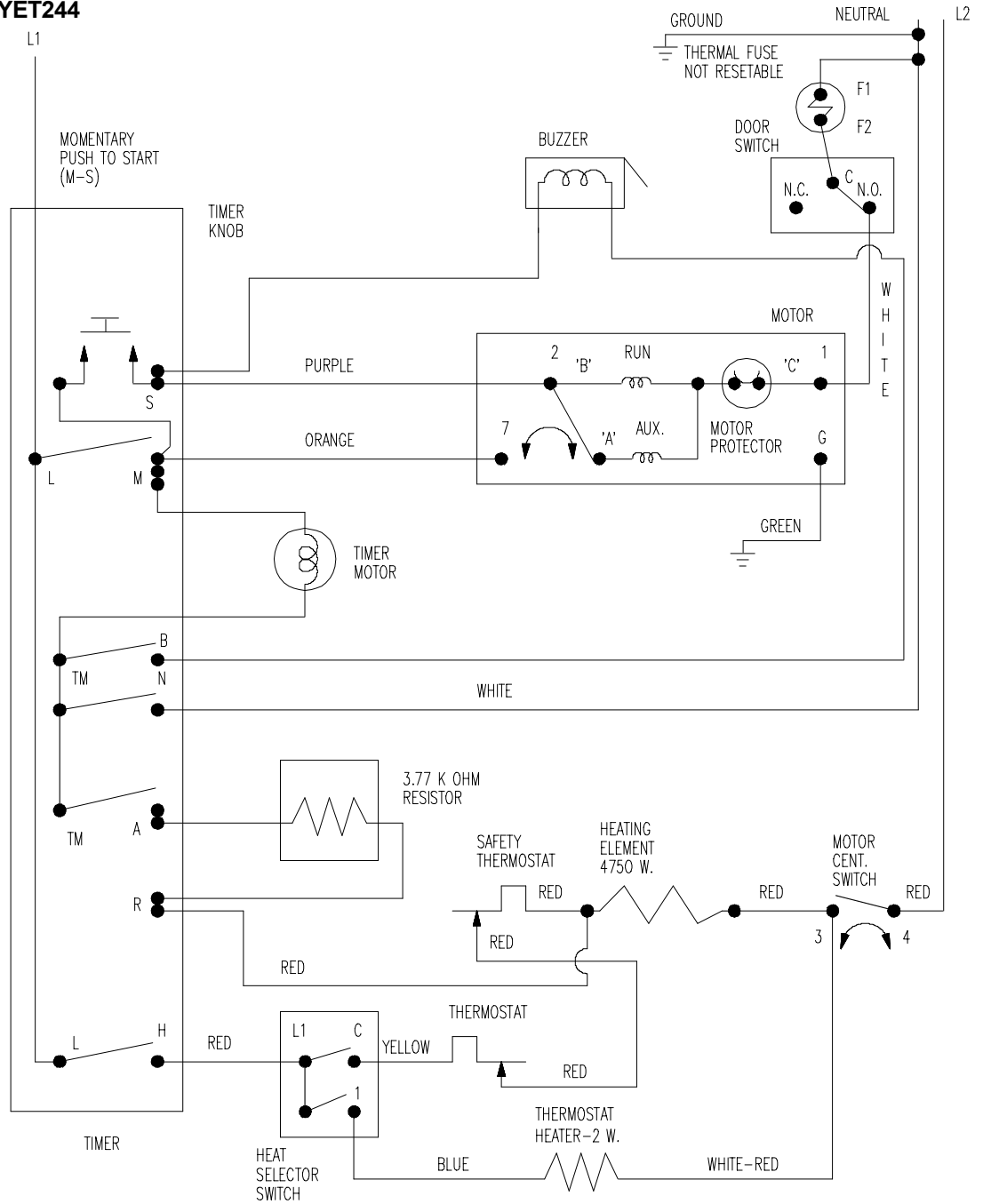

CONNECT DRYER TO 120/240 V.A.C., 60 HZ. INDIVIDUAL BRANCH CIRCUIT PROTECTED BY MAXIMUM 30 A. FUSES. ALWAYS GIVE THE SERIAL & MODEL NUMBERS WHEN WRITING ABOUT THIS DRYER OR ORDERING PARTS.

CONNECT DRYER TO 120/240 V.A.C., 60 HZ. INDIVIDUAL BRANCH CIRCUIT PROTECTED BY MAXIMUM 30 A. FUSES. ALWAYS GIVE THE SERIAL & MODEL NUMBERS WHEN WRITING ABOUT THIS DRYER OR ORDERING PARTS.

TIMER SEQUENCE					HEAT SELECTOR SWITCH	
	TIMER—ROTATES 1.6 PER MINUTE			POSITION	CONTACTS	
	O F F	AUTO REGULAR	O F F	AUTO PERM. PRESS	O F F	TIMED DRY
TM-B						
L-H	■	■		■		
TM-A	■	■		■		
TM-N		■		■		
L-M	■	■		■		
M-S						
	MINUTES					
	0	22	31	0	28	53
						0
						20
						40
						60
						80
						103
						112.5
	MOTOR WIRING CODE					
	MOTOR	A	B	C		
	EMERSON	RED	YELLOW	BLUE		

WIRING INFORMATION

PYE2300, HYE2460, PYET244

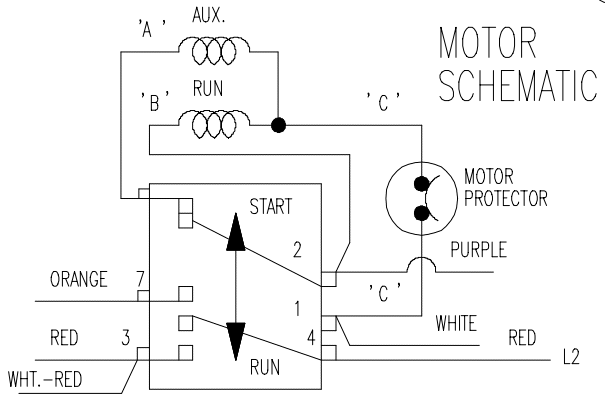
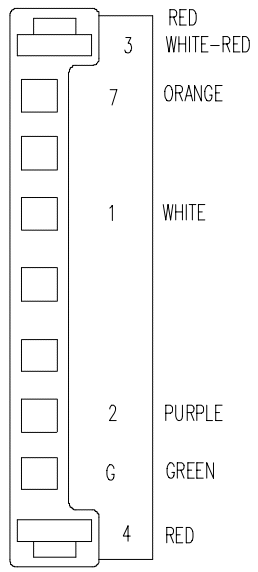
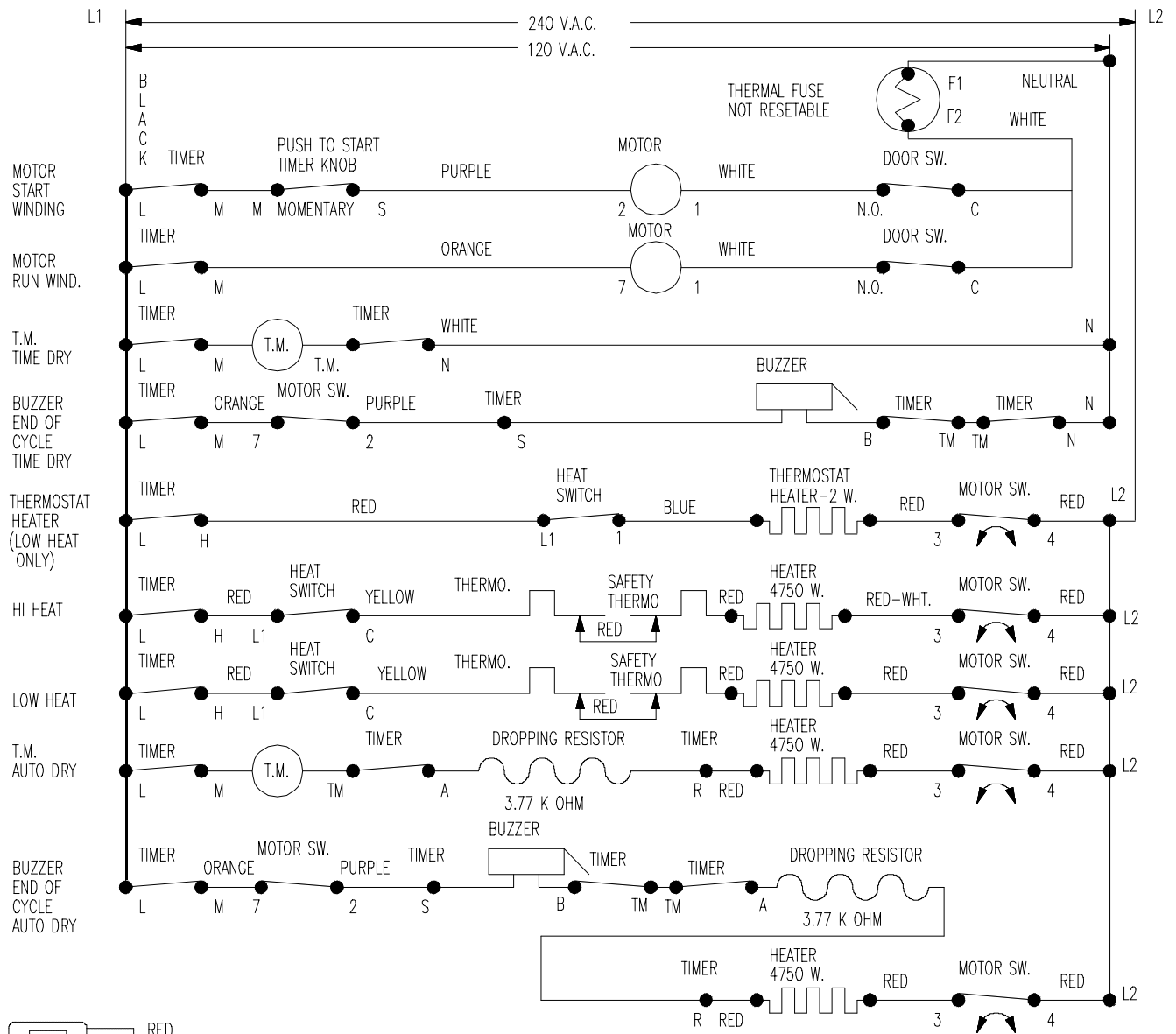

53-3540 "REL"

WIRING INFORMATION

PYG2300

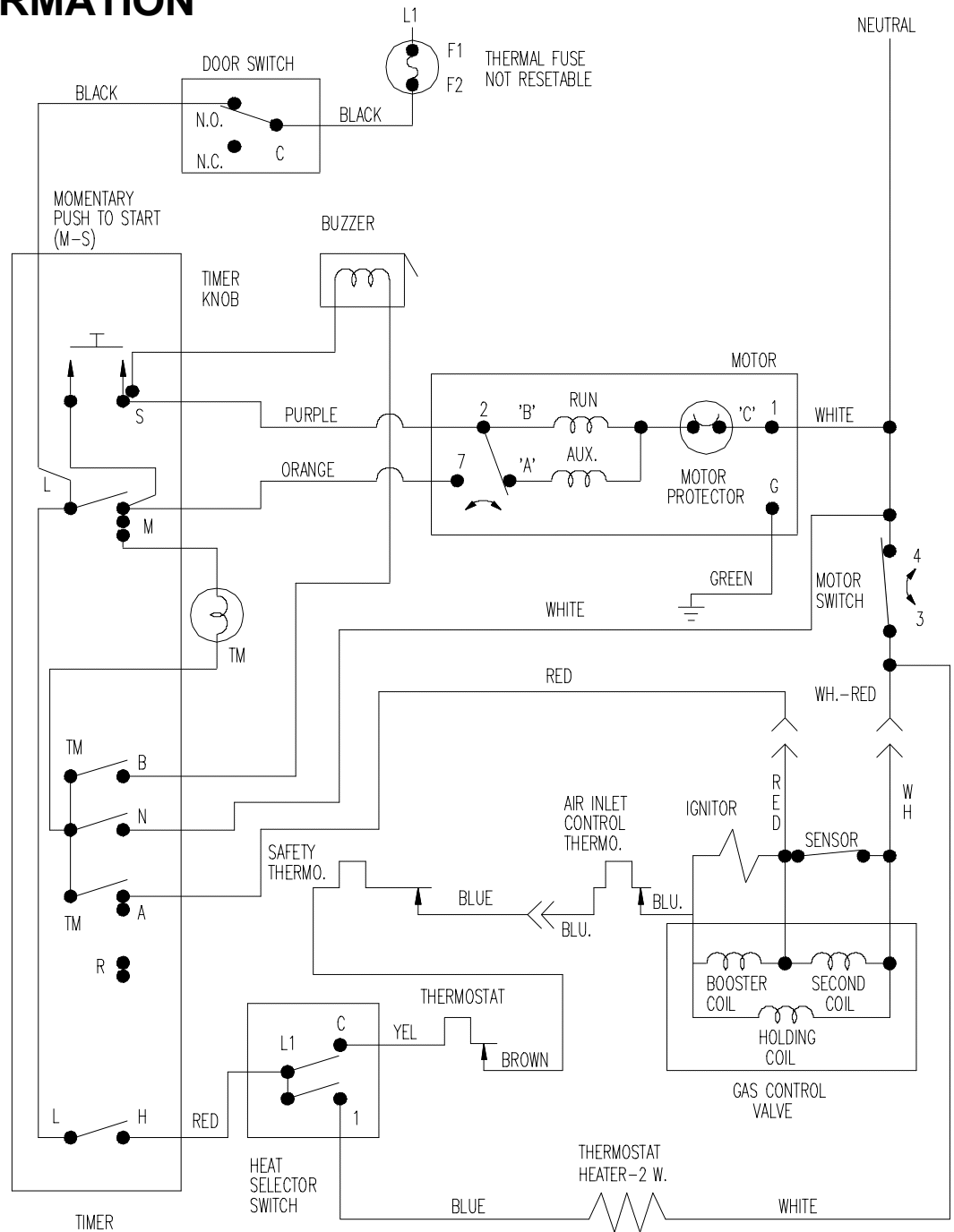

TIMER SEQUENCE					HEAT SELECTOR SWITCH			
TIMER—ROTATES 1.6 PER MINUTE					POSITION	CONTACTS		
	O F F	AUTO REGULAR	O F F	AUTO PERMANENT PRESS	FLUFF			
TM-B					LOW	L1-1, L1-C		
L-H	■		■	■	REGULAR	L1-C		
TM-A	■		■	■				
TM-N		■		■				
L-M	■		■	■				
M-S								
	0	22	0	28	MOTOR WIRING CODE			
	31		53	0				
MINUTES					MOTOR	A	B	C
					EMERSON	RED	YELLOW	BLUE

WIRING INFORMATION

PYG2300

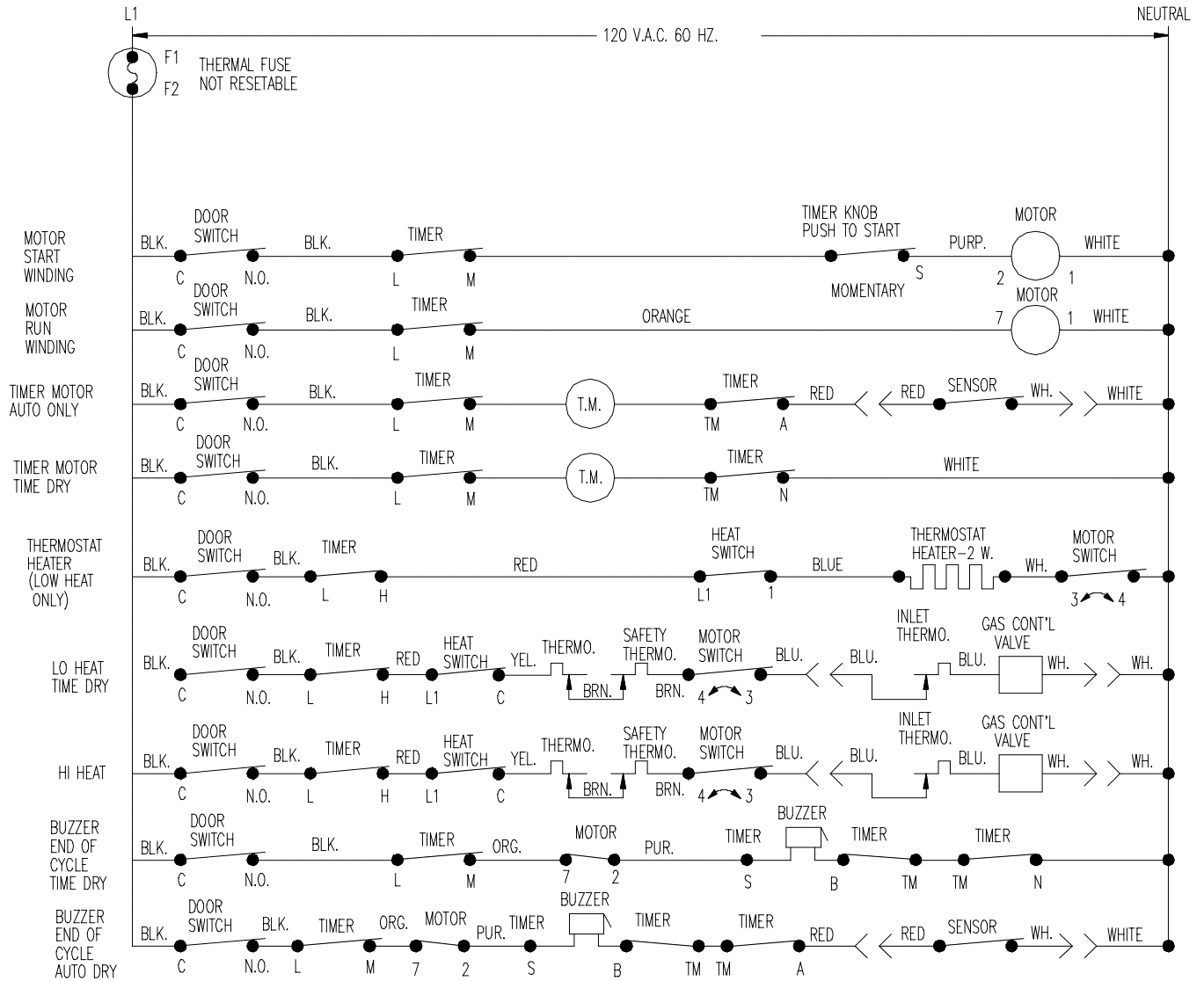

53-3539 "REL"

NOTICE:
CONNECT GROUND WIRE SECURELY
DO NOT GROUND TO GAS PIPE.

MOTOR SCHEMATIC

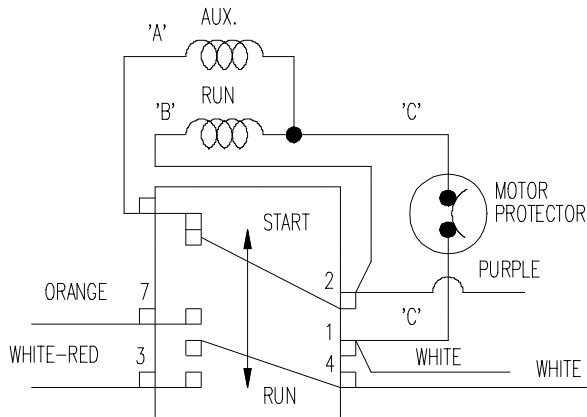

MOTOR TERMINALS

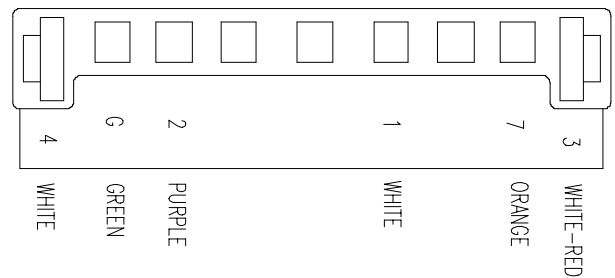

WIRING INFORMATION

PYE3200/3300

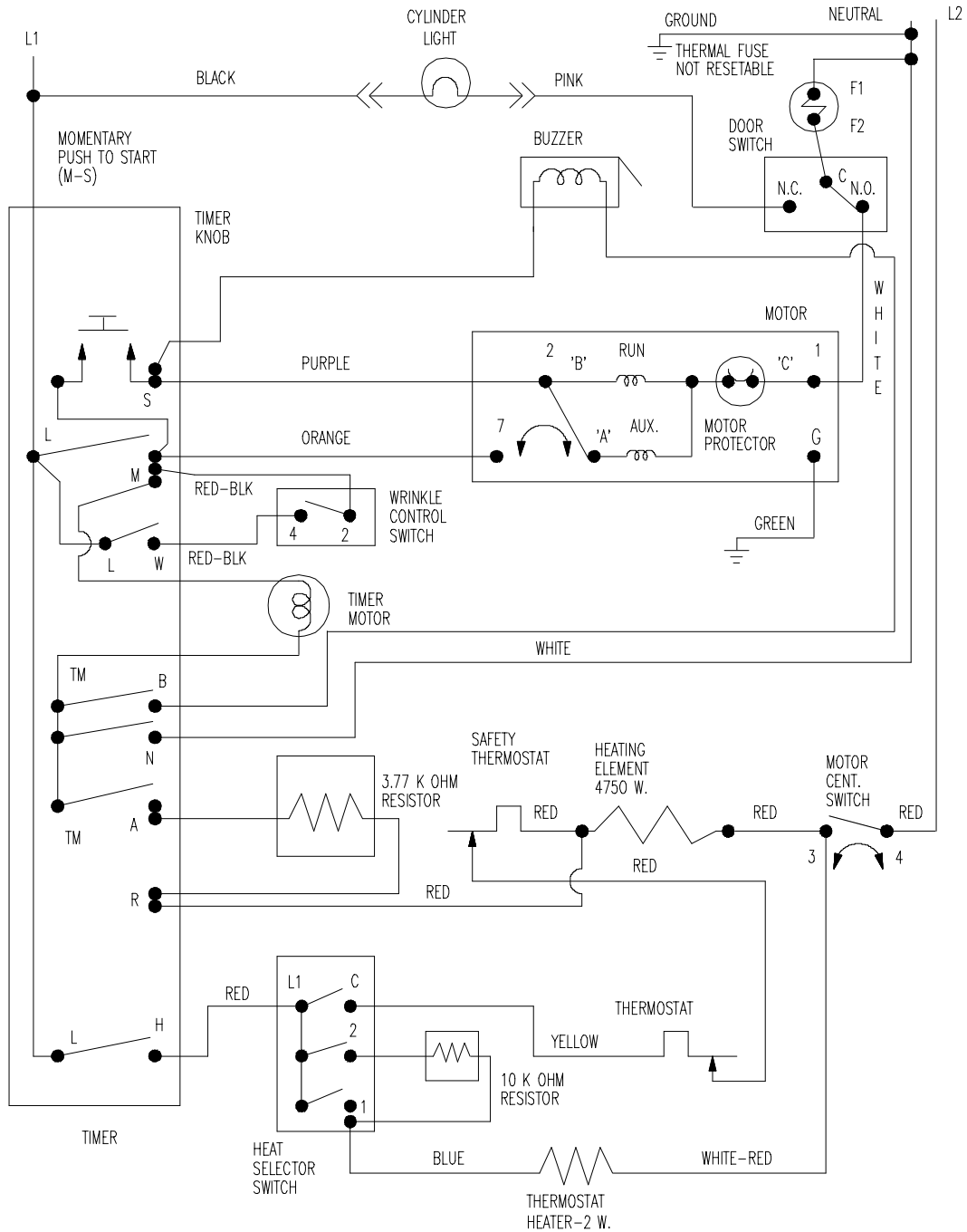

CONNECT DRYER TO 120/240 V.A.C., 60 HZ PROTECTED BY MAXIMUM 30 A. FUSES. ALWAYS GIVE THE SERIAL & MODEL NUMBERS WHEN WRITING ABOUT THIS DRYER

Z. INDIVIDUAL BRANCH CIRCUIT WAYS GIVE THE SERIAL & MODEL NO OR ORDERING PARTS

TIMER SEQUENCE						HEAT SELECTOR SWITCH		WRINKLE CONTROL SWITCH	
TIMER - ROTATES 1.33 PER MINUTE						POSITION	CONTACTS	POSITION	CIRCUIT
	OFF	AUTO REGULAR	OFF	AUTO PERM. PRESS	WRINKLE OUT	OFF	TIMED DRY	ON	2-4
TM-B								OFF	---
L-H	■	■	■	■	■				
TM-A	■	■	■	■	■				
L-W					■				
TM-N	■								
L-M	■	■	■	■	■				
M-S									
						MOTOR WIRING CODE			
						MOTOR	A	B	C
						EMERSON	RED	YELLOW	BLUE
MIN.	0	15	25.5	0	16.5	30	50	79	89
						0	30	60	90
									109 119.5

WIRING INFORMATION

PYE3200/3300

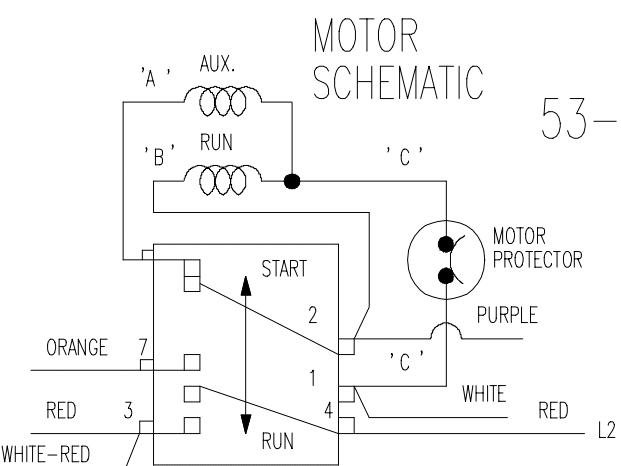
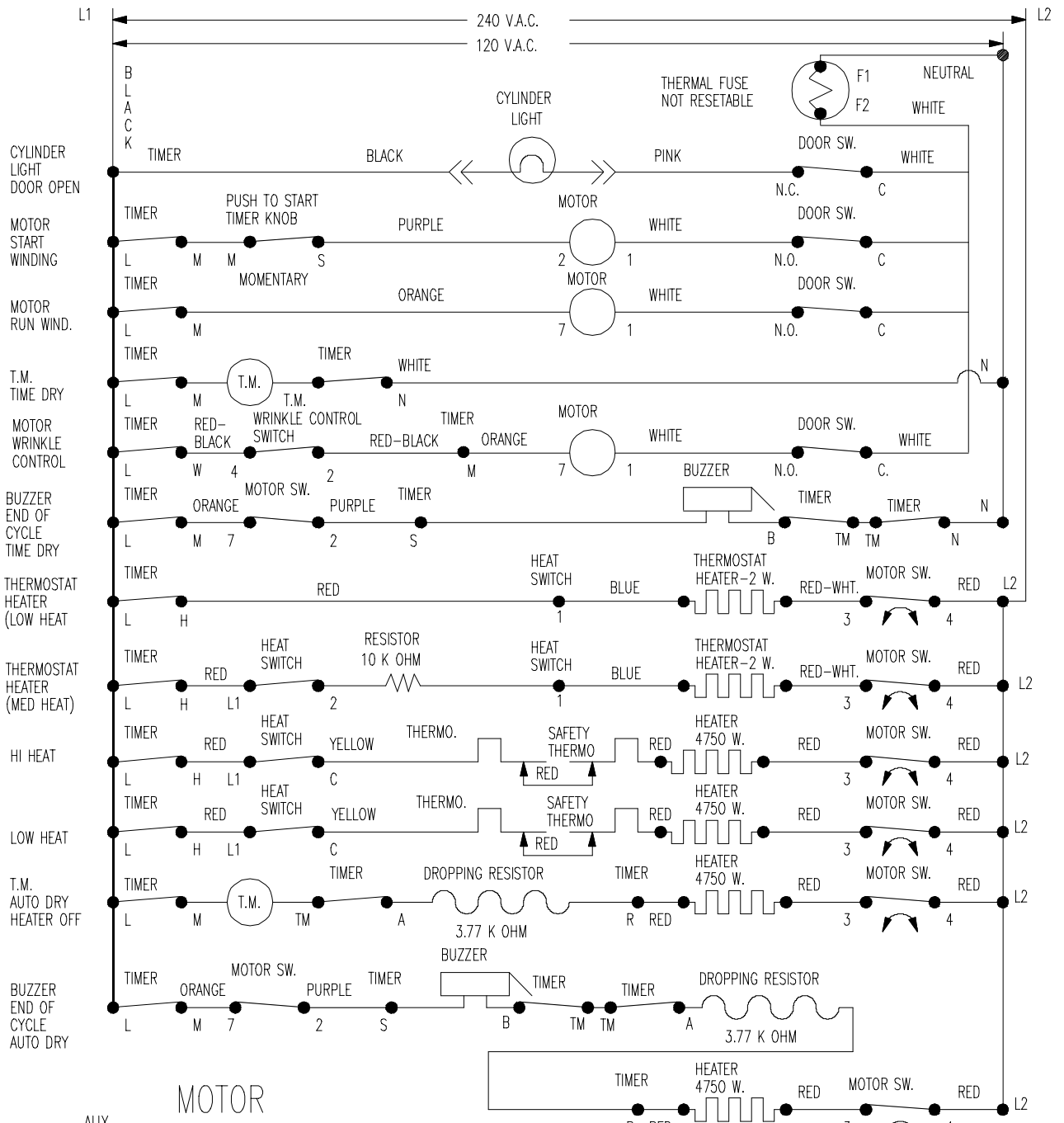

53-3542 "REL"

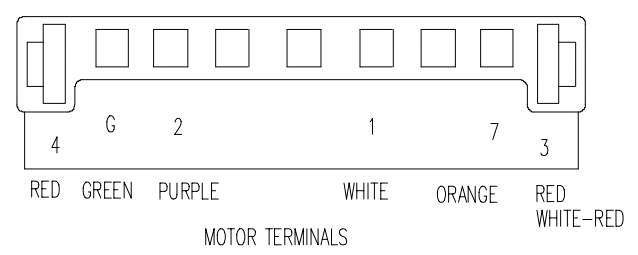

WIRING INFORMATION

PYG3200/3300

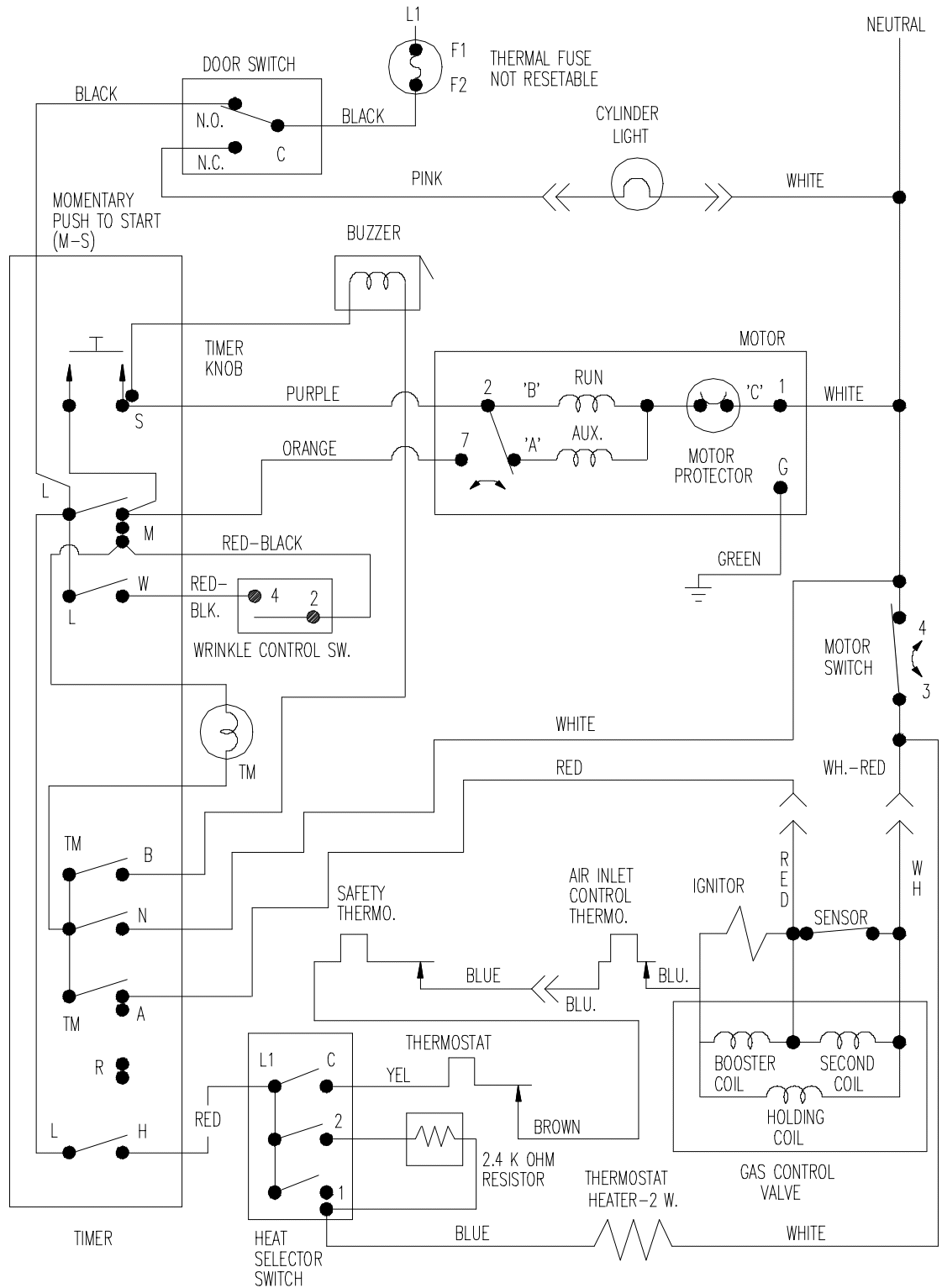

Caution: Label all wires prior to disconnection when servicing controls. Wiring error can cause improper and dangerous operation. Verify proper operation after servicing.

TIMER SEQUENCE						HEAT SELECTOR SWITCH		WRINKLE CONTROL SW.							
TIMER—ROTATES 1.33 PER MINUTE						POSITION	CIRCUIT	POSITION	CIRCUIT						
	O F F	AUTO REGULAR	O F F	AUTO PERM. PRESS	Wrinkle OUT	O F F	TIMED DRY	ON	2 - 4						
TM-B	II														
L-H	■	■	■	■	■										
TM-A	■	■	■	■	■										
L-W			■	■	■										
TM-N	■		■	■	■										
L-M	■	■	■	■	■										
M-S															
MIN.	0	15	25.5	0	16.5	30	50	79	89	0	30	60	90	109	119.5
						MOTOR WIRING CODE									
						MOTOR	A	B	C						
						EMERSON	RED	YELLOW	BLUE						

WIRING INFORMATION

PYG3200/3300

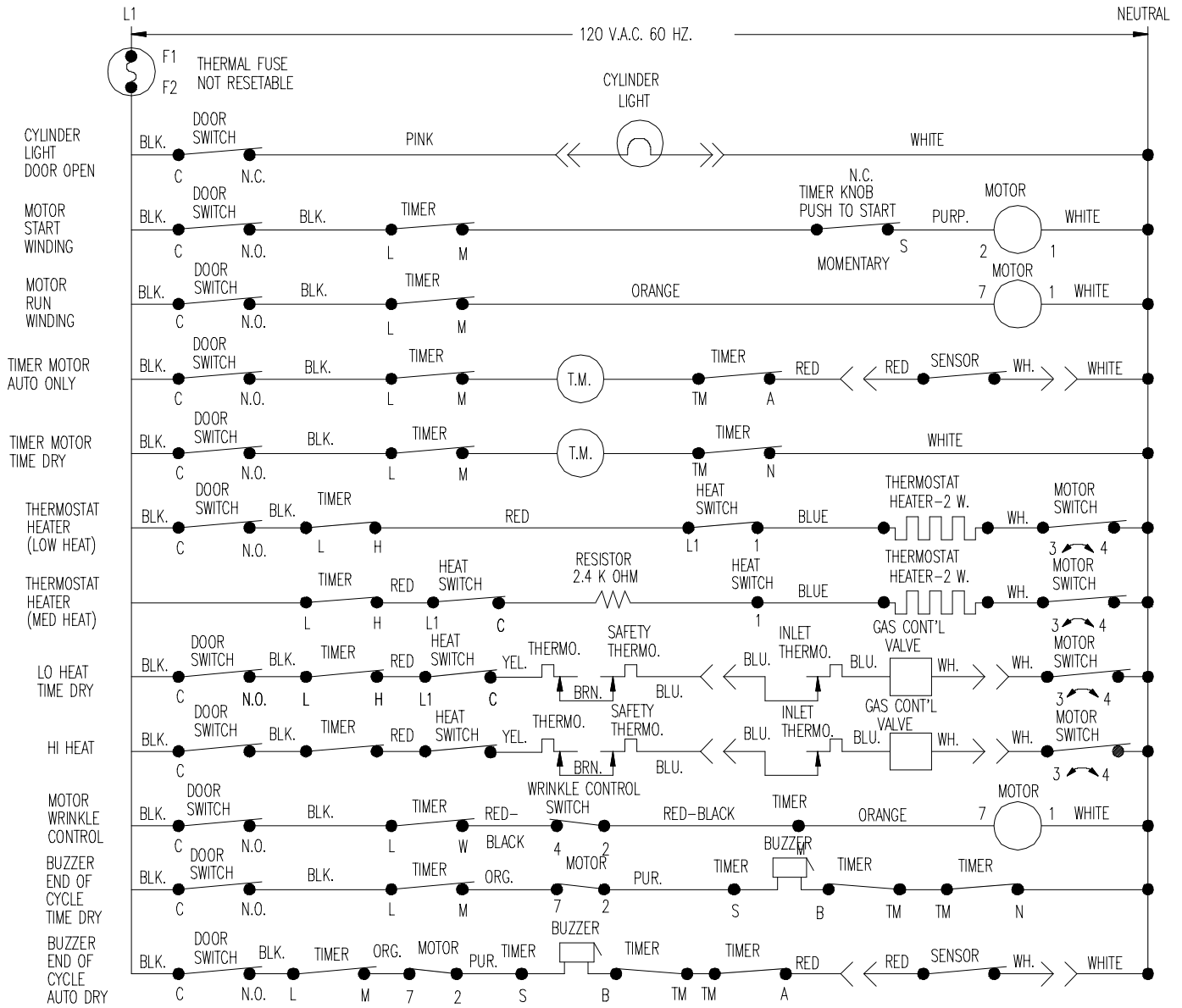

53-3541 "REL"

NOTICE:
CONNECT GROUND WIRE SECURELY
DO NOT GROUND TO GAS PIPE.

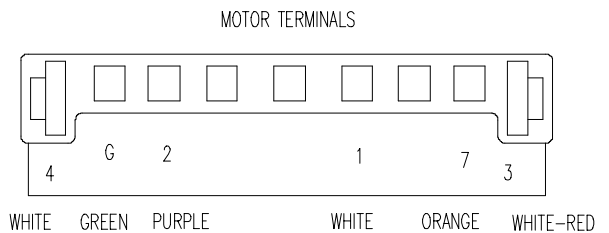
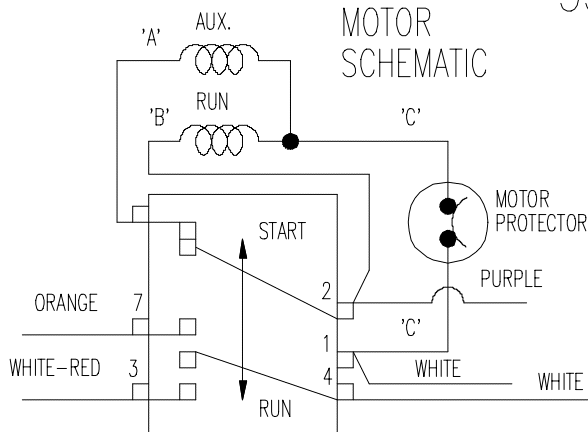

WIRING INFORMATION

PYE4500/4557/4558

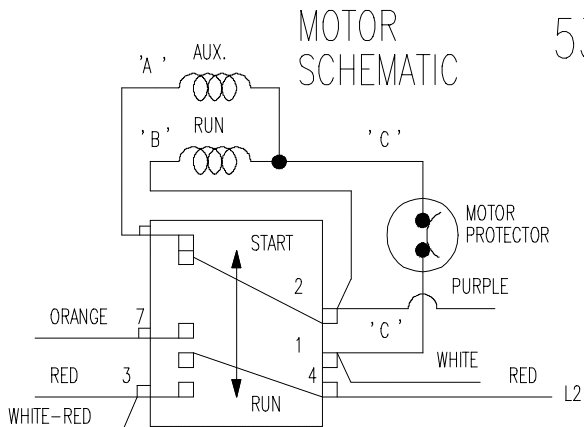
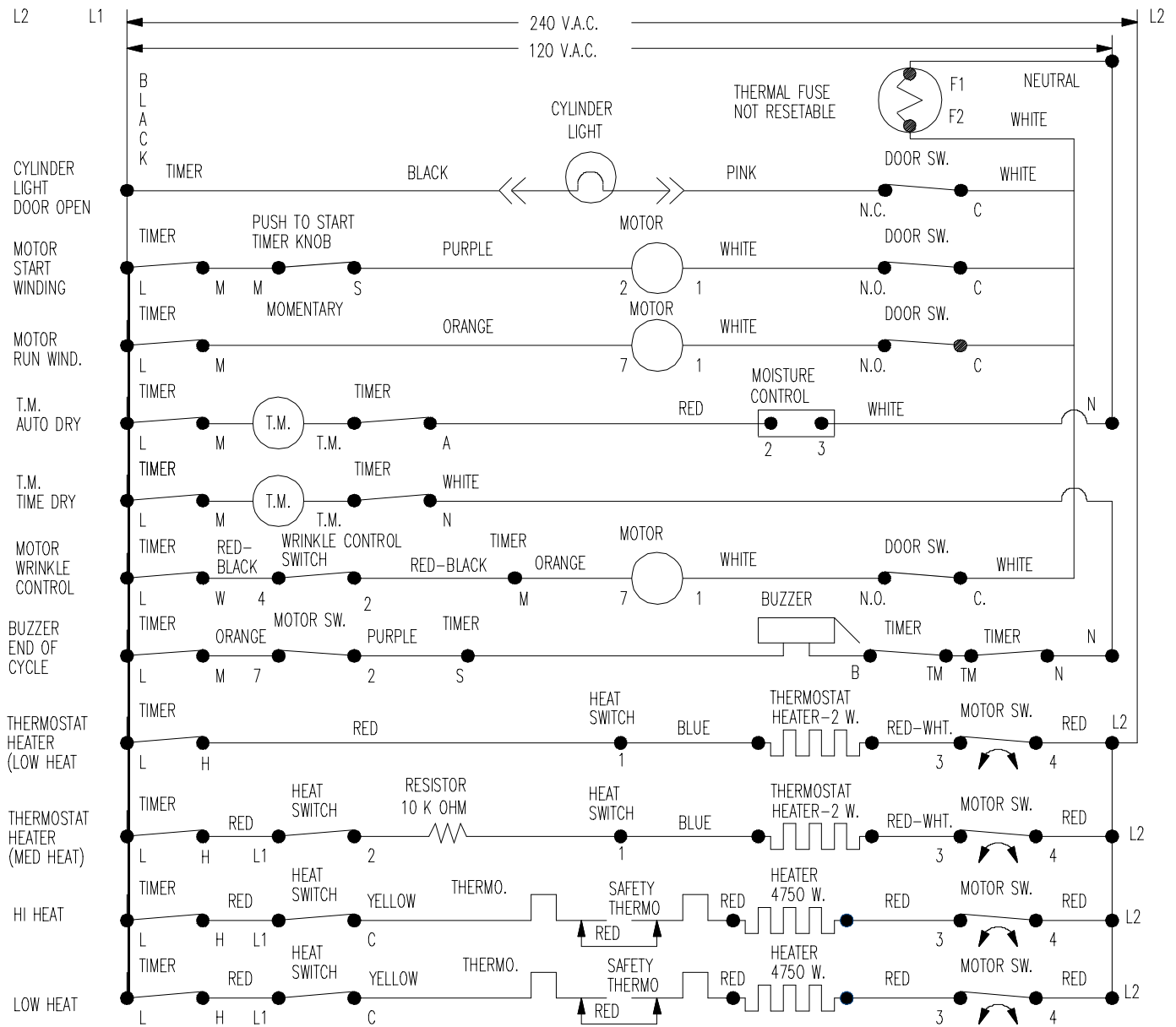

53-3749 "B"

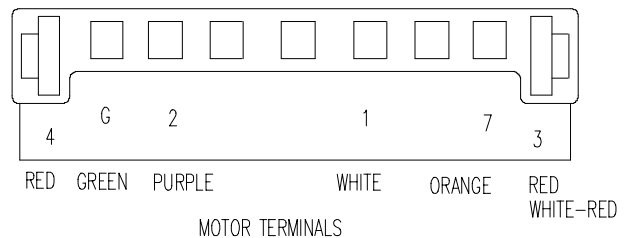

WIRING INFORMATION

PYG4500/4557/4558

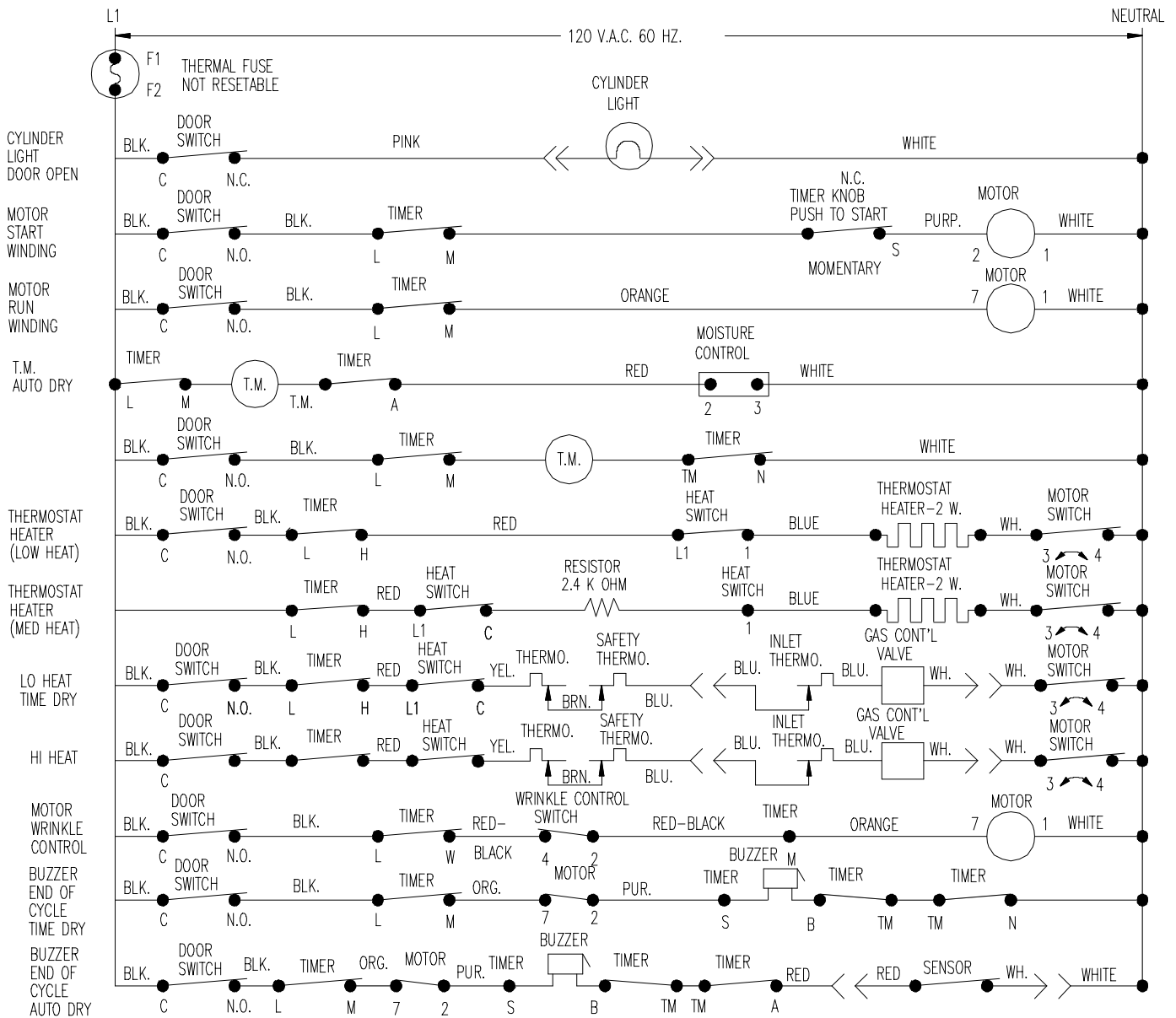

53-3750 "A"

NOTICE:
CONNECT GROUND WIRE SECURELY
DO NOT GROUND TO GAS PIPE.

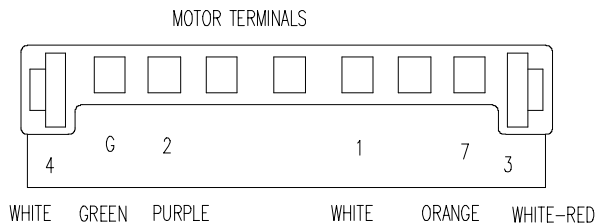
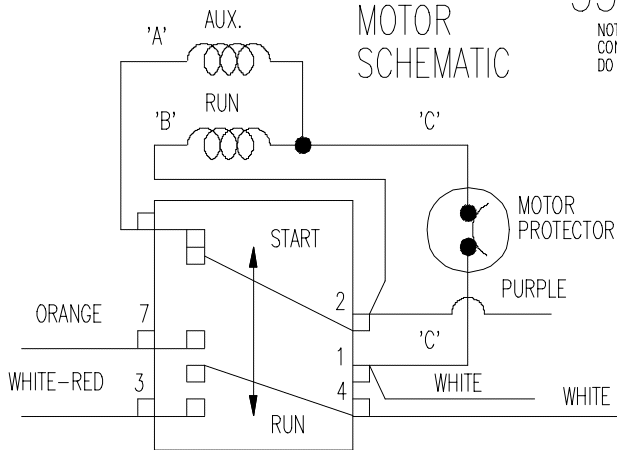

WIRING INFORMATION

HYE3657, HYE3658, PYET344

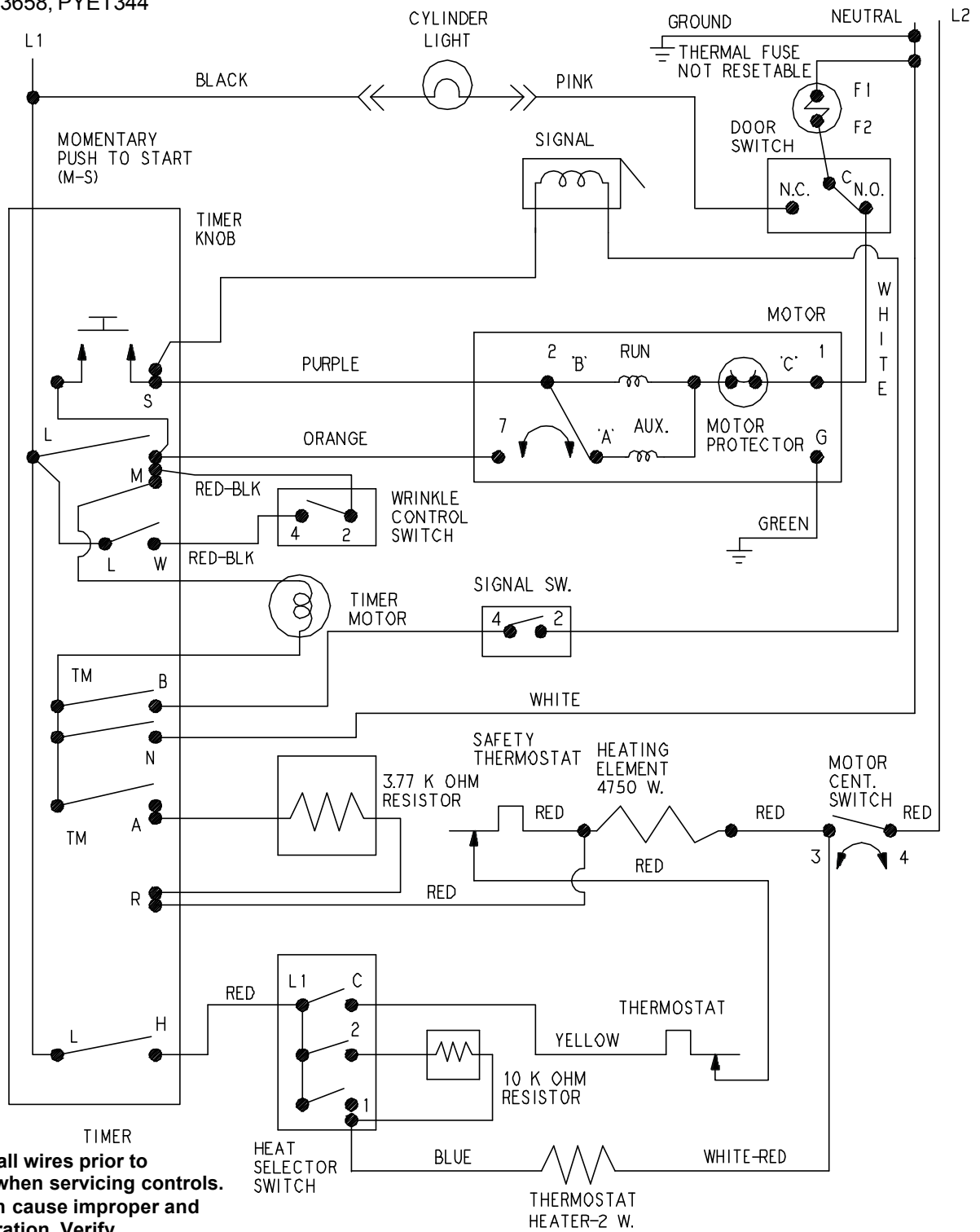

Caution: Label all wires prior to disconnection when servicing controls. Wiring error can cause improper and dangerous operation. Verify proper operation after servicing.

TIMER SEQUENCE						HEAT SELECTOR SWITCH		WRINKLE CONTROL SWITCH		SIGNAL SW					
TIMER-ROTATES 1.33 DEGREES PER MINUTE						POSITION	CONTACTS	POSITION	CIRCUIT	POS.	CIRCUIT				
	OFF	AUTO REGULAR	OFF	AUTO PERM. PRESS	WRINKLE OUT	OFF	TIMED DRY	ON	2-4	ON	2-4				
TM-B	█	█	█	█	█	LOW	L1-1, L1-C	OFF	---	OFF	---				
L-H	█	█	█	█	█	MEDIUM	L1-C, L1-2								
TM-A	█	█	█	█	█	HIGH	L1-C								
L-W	█	█	█	█	█										
TM-N	█	█	█	█	█										
L-M	█	█	█	█	█										
M-S	█	█	█	█	█										
						MOTOR WIRING CODE									
						MOTOR	A	B	C						
						EMERSON	RED	YELLOW	BLUE						
MIN.	0	15	25.5	0	16.5	30	50	79	89	0	30	60	90	109	119.5

MAYTAG

Maytag Appliances Sales Company

Customer Service
240 Edwards St.
Cleveland, TN 37311