



Service

This manual is to be used by qualified appliance technicians only. Maytag does not assume any responsibility for property damage or personal injury for improper service procedures done by an unqualified person.

This Base Manual covers general information

Refer to individual Technical Sheet for information on specific models

This manual includes, but is not limited to the following:

Amana

AB1924PEK*

AB2026PEK*

AB2225PEK*

AB2226PEK*

AB2526PEK*

G32026PEK*

G32526PEK*

GB1924PEK*

GB2225PEK*

GB2526PEK*

International Bottom Mount Refrigerators



Important Information

Important Notices for Servicers and Consumers

Maytag will not be responsible for personal injury or property damage from improper service procedures. Pride and workmanship go into every product to provide our customers with quality products. It is possible, however, that during its lifetime a product may require service. Products should be serviced only by a qualified service technician who is familiar with the safety procedures required in the repair and who is equipped with the proper tools, parts, testing instruments and the appropriate service information. **IT IS THE TECHNICIANS RESPONSIBILITY TO REVIEW ALL APPROPRIATE SERVICE INFORMATION BEFORE BEGINNING REPAIRS.**



WARNING

To avoid risk of severe personal injury or death, disconnect power before working/servicing on appliance to avoid electrical shock.

To locate an authorized servicer, please consult your telephone book or the dealer from whom you purchased this product. For further assistance, please contact:

Customer Service Support Center

CAIR Center

Web Site	Telephone Number
WWW.AMANA.COM	1-800-843-0304
WWW.JENNAIR.COM	1-800-536-6247
WWW.MAYTAG.COM	1-800-688-9900
CAIR Center in Canada	1-800-688-2002
Amana Canada Product	1-866-587-2002

Recognize Safety Symbols, Words, and Labels



DANGER

DANGER—Immediate hazards which **WILL** result in severe personal injury or death.



WARNING

WARNING—Hazards or unsafe practices which **COULD** result in severe personal injury or death.



CAUTION

CAUTION—Hazards or unsafe practices which **COULD** result in minor personal injury, product or property damage.

Table of Contents

Important Information	2	Water Tank	30
Product Design	4	Water Dispenser	31
Component Testing	5	Freezer Compartment	
Service Procedures	10	Freezer Thermistor	31
Service Equipment	10	Light Socket	31
Drier Replacement	10	Light Switch	31
Refrigerant Precautions	11	Freezer Back Panel	31
Line Piercing Valves	11	Evaporator Fan and Evaporator Motor	31
Open Lines	11	Defrost Terminator (thermostat)	32
Compressor Operational Test	11	Defrost Heater	32
Dehydrating Sealed Refrigeration System	12	Evaporator Removal	32
Leak Testing	12	Drawer Assembly	33
Testing Systems Containing a		Drawer Rails	33
Refrigerant Charge	12	Rack and Pinion Gear	33
Testing Systems Containing		Bottom of Cabinet	
No Refrigerant Charge	12	Front roller assembly	33
Restrictions	13	Rear roller assembly.....	33
Symptoms	13	Machine Compartment	
Testing for Restrictions	13	Condenser Fan and Fan motor	33
Evacuation and Charging	14	Compressor	33
Evacuation	14	Overload/Relay/Capacitor	34
Charging	15	Condensate Drain Pan	34
Refrigerant Charge	15	Condensate Drain Tube	34
HFC134a Service Information	16	Condenser Removal	34
Health, Safety, and Handling	16	Control Board (Mid Level)	
Comparison of CFC12 and HFC134a Properties	16	Programming Mode	35
Replacement Service Compressor	17	Defrost Operation	35
Compressor Testing Procedures	17	Forced Defrost Mode	35
Brazing	17	Service Test Mode	36
Refrigerant Flow	18	Service Test 1-Defrost Thermostat & Defrost Circuit	
Cabinet Air Flow	19	Test	37
Two Way Machine Compartment Air Flow Diagram	20	Service Test 2-Compressor/Condenser Fan Test	37
One Way Machine Compartment		Service Test 3-Evaporator/Freezer Fan Test	37
Air Flow Diagram	21	Service Test 4-Fresh Food Thermistor Test	38
Typical External Sweat Pattern.....	22	Service Test 5-Freezer Thermistor Test	38
Troubleshooting Chart.....	23	Service Test 6-Open Damper Test	39
System Diagnosis	26	Service Test 7-FF Performance Adjustment	39
Disassembly Procedures		Service Test 8-FZ Performance Adjustment	39
Fresh Food Door	29		
Freezer Door	29		
Freezer Drawer	29		
Refrigerator Compartment			
Light Bulb	29		
Light Bulb Assembly	29		
Light Bulb Sockets	30		
PC Control Board	30		
Light Switch	30		
Temp- Assure™ Damper control	30		
Fresh Food Thermistor	30		

Product Design



WARNING

To avoid risk of electrical shock, personal injury, or death, disconnect electrical power source to unit, unless test procedures require power to be connected. Discharge capacitor through a resistor before attempting to service. Ensure all earthing wires are connected before certifying unit as repaired and/or operational.

Refrigeration System

Compressor forces high temperature vapor into fan cooled tube and wire condenser where vapor is cooled and condensed into high pressure liquid by circulation of air across condenser coil. (See Refrigerant Flow Diagram, page 18)

High pressure liquid passes into post-condenser loop which helps to prevent condensation around freezer compartment opening and through molecular sieve drier and into capillary tube. Small inside diameter of capillary offers resistance, decreasing pressure, and temperature of liquid discharged into evaporator. Capillary diameter and length is carefully sized for each system.

Capillary enters evaporator at top front. Combined liquid and saturated gas flows through front to bottom of coil and into suction line. Aluminum tube evaporator coil is located in freezer compartment where circulating evaporator fan moves air through coil and into fresh food compartment.

Large surface of evaporator allows heat to be absorbed from both fresh food and freezer compartments by airflow over evaporator coil causing some of the liquid to evaporate. Temperature of evaporator tubing near end of running cycle may vary from -25°C to -32°C .

Saturated gas is drawn off through suction line where superheated gas enters compressor. To raise temperature of gas, suction line is placed in heat exchange with capillary.

Temperature Controls

Freezer compartment temperature is regulated by air sensing thermostat at top front of freezer compartment which actuates compressor. Control should be set to maintain freezer temperature between -17.8°C to -18.9°C .

Fresh food compartment temperature is regulated by an air damper control governing amount of refrigerated air entering fresh food compartment from freezer. Fresh food compartment temperature should be between 3.3°C and 4.4°C .

Defrost System

Mid Level Electronic Defrost

The Control Board adapts the compressor run time between defrosts to achieve optimum defrost intervals by monitoring the length of time the defrost heater is on.

After initial power up, defrost interval is 4 hours compressor run time. Defrost occurs immediately after the 4 hours.

Note: Once unit is ready to defrost there is a 4 minute wait time prior to the beginning of the defrost cycle.

Optimum defrost is 15 minutes. Each additional minute the defrost thermostat remains closed, 1 hr. is subtracted from the previous defrost interval. Each minute the thermostat opens prior to optimum defrost, it extends the next defrost interval 1 hr. When defrost thermostat opens there is a 4-6 minute drip time before compressor restarts or Control Board will terminate defrost at 25 minutes if defrost thermostat has not opened and will reset the defrost interval to the 8 hr. minimum setting.

4 hours of continuous compressor run resets the next defrost interval to 8 hours and will initiate a defrost, if 8 hours of compressor run time has also occurred.

Component Testing



WARNING

To avoid risk of electrical shock, personal injury, or death, disconnect electrical power source to unit, unless test procedures require power to be connected. Discharge capacitor through a resistor before attempting to service. Ensure all earthing wires are connected before certifying unit as repaired and/or operational.



Component	Description	Test Procedures
<div data-bbox="186 472 332 630" data-label="Image"> </div> <p data-bbox="162 409 284 430">Compressor</p>	<p data-bbox="350 409 743 619">When compressor electrical circuit is energized, the start winding current causes relay to heat. After an amount of starting time, the start winding circuit turns off. The relay will switch off the start winding circuit even though compressor has not started (for example, when attempting to restart after momentary power interruption).</p> <p data-bbox="350 640 743 766">With "open" relay, compressor will not start because there is little or no current to start windings. Overload protection will open due to high locked rotor run winding current.</p> <p data-bbox="350 787 743 913">With "shorted" relay or capacitor, compressor will start and overload protector will quickly open due to high current of combined run and start windings.</p> <p data-bbox="350 934 743 1018">With open or weak capacitor, compressor will start and run as normal but will consume more energy.</p>	<p data-bbox="750 409 909 430">Resistance test</p> <ol data-bbox="750 430 1515 472" style="list-style-type: none"> 1. Disconnect power to unit. 2. Discharge capacitor by shorting across terminals with a resistor for 1 minute. <p data-bbox="750 472 1291 493">NOTE: (Some compressors do not have a run capacitor.)</p> <ol data-bbox="750 493 1515 661" style="list-style-type: none"> 3. Remove leads from compressor terminals. 4. Set ohmmeter to lowest scale. 5. Check for resistance between <ul data-bbox="844 567 1185 619" style="list-style-type: none"> Terminals "S" and "C", start winding Terminals "R" and "C", run winding <p data-bbox="795 619 1515 661">If either compressor winding reads open (infinite or very high resistance) or dead short (0 ohms), replace compressor.</p> <p data-bbox="750 682 876 703">Ground test</p> <ol data-bbox="750 703 1515 850" style="list-style-type: none"> 1. Disconnect power to refrigerator. 2. Discharge capacitor, if present, by shorting terminals through a resistor. 3. Remove compressor leads and use an ohmmeter set on highest scale. 4. Touch one lead to compressor body (clean point of contact) and other probe to each compressor terminal. <ul data-bbox="779 829 1461 850" style="list-style-type: none"> • If reading is obtained, compressor is grounded and must be replaced. <p data-bbox="750 861 901 882">Operation test</p> <p data-bbox="750 882 1515 934">If voltage, capacitor, overload, and motor winding tests do not show cause for failure, perform the following test:</p> <ol data-bbox="750 934 1515 1207" style="list-style-type: none"> 1. Disconnect power to refrigerator. 2. Discharge capacitor by shorting capacitor terminals through a resistor. 3. Remove leads from compressor terminals. 4. Wire a test cord to power switch. 5. Place time delayed fuse with UL rating equal to amp rating of motor in test cord socket. (Refer to Technical Data Sheet) 6. Remove overload and relay. 7. Connect start, common and run leads of test cord on appropriate terminals of compressor. 8. Attach capacitor leads of test cord together. If capacitor is used, attach capacitor lead to a known good capacitor of same capacity. <div data-bbox="966 1207 1299 1564" data-label="Diagram"> <p data-bbox="1047 1564 1218 1585">Test configuration</p> </div> <ol data-bbox="750 1596 1515 1900" style="list-style-type: none"> 9. Plug test cord into multimeter to determine start and run wattage and to check for low voltage, which can also be a source of trouble indications. 10. With power to multimeter, press start cord switch and release. <ul data-bbox="779 1669 1515 1900" style="list-style-type: none"> • If compressor motor starts and draws normal wattage, compressor is okay and trouble is in capacitor, relay/overload, freezer temperature control, or elsewhere in system. • If compressor does not start when direct wired, recover refrigerant at high side. After refrigerant is recovered, repeat compressor direct wire test. If compressor runs after recovery but would not run when direct wired before recover, a restriction in sealed system is indicated. • If compressor does not run when wired direct after recovery, replace faulty compressor.

Component Testing

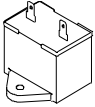

WARNING

To avoid risk of electrical shock, personal injury, or death, disconnect electrical power source to unit, unless test procedures require power to be connected. Discharge capacitor through a resistor before attempting to service. Ensure all earthing wires are connected before certifying unit as repaired and/or operational.

Component	Description	Test Procedures
<p>Capacitor</p> 	<p>Run capacitor connects to relay terminal 3 and L side of line.</p> <p>Some compressors do not require a run capacitor; refer to the Technical Data Sheet for the unit being serviced.</p>	<div style="border: 1px solid black; padding: 5px; margin-bottom: 10px;">  <h3 style="margin: 0;">WARNING</h3> <p>To avoid electrical shock which can cause severe personal injury or death, discharge capacitor through a resistor before handling.</p> </div> <ol style="list-style-type: none"> 1. Disconnect power to refrigerator. 2. Remove capacitor cover and disconnect capacitor wires. 3. Discharge capacitor by shorting across terminals with a resistor for 1 minute. 4. Check resistance across capacitor terminals with ohmmeter set on "X1K" scale. <ul style="list-style-type: none"> • Good—needle swings to 0 ohms and slowly moves back to infinity. • Open—needle does not move. Replace capacitor. • Shorted—needle moves to zero and stays. Replace capacitor. • High resistance leak—needle jumps toward 0 and then moves back to constant high resistance (not infinity).
<p>Condenser</p>	<p>Condenser is a tube and wire construction located in machine compartment.</p> <p>Condenser is on high pressure discharge side of compressor. Condenser function is to transfer heat absorbed by refrigerant to ambient.</p> <p>Higher pressure gas is routed to condenser where, as gas temperature is reduced, gas condenses into a high pressure liquid state. Heat transfer takes place because discharged gas is at a higher temperature than air that is passing over condenser. It is very important that adequate air flow over condenser is maintained.</p> <p>Condenser is air cooled by condenser fan motor. If efficiency of heat transfer from condenser to surrounding air is impaired, condensing temperature becomes higher. High liquid temperature means liquid will not remove as much heat during boiling in evaporator as under normal conditions. This would be indicated by high than normal head pressures, long run time, and high wattage. Remove any lint or other accumulation, that would restrict normal air movement through condenser.</p> <p>From condenser the refrigerant flows into a post condenser loop which helps control exterior condensation on flange, center mullion, and around freezer door. Refrigerant the flows through the drier to evaporator and into compressor through suction line.</p>	<p>Leaks in condenser can usually be detected by using an electronic leak detector or soap solution. Look for signs of compressor oil when checking for leaks. A certain amount of compressor oil is circulated with refrigerant.</p> <p>Leaks in post condenser loop are rare because loop is a one-piece copper tube.</p> <p>For minute leaks:</p> <ol style="list-style-type: none"> 1. Separate condenser from rest of refrigeration system and pressurize condenser up to a maximum of 16.20 Bar with a refrigerant and dry nitrogen combination. 2. Recheck for leaks. <div style="border: 1px solid black; padding: 5px; margin-top: 10px;">  <h3 style="margin: 0;">WARNING</h3> <p>To avoid severe personal injury or death from sudden eruption of high pressures gases, observe the following: Protect against a sudden eruption if high pressures are required for leak checking. Do not use high pressure compressed gases in refrigeration systems without a reliable pressure regulator and pressure relief valve in the lines.</p> </div>

Component Testing



WARNING

To avoid risk of electrical shock, personal injury, or death, disconnect electrical power source to unit, unless test procedures require power to be connected. Discharge capacitor through a resistor before attempting to service. Ensure all earthing wires are connected before certifying unit as repaired and/or operational.

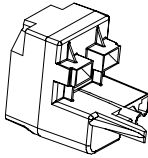
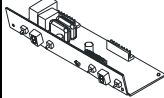
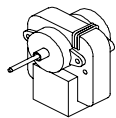
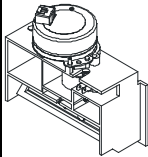

Component	Description	Test Procedures
<p>Overload / Relay</p> 	<p>When voltage is connected and relay is cool, current passes through relay to start winding.</p> <p>After a short time, current heats the resistor in relay and resistance will rise blocking current flow through relay.</p> <p>Start winding remains in the circuit through run capacitor.</p> <p>Solid state relay plugs directly on compressor start and run terminals. Relay terminals 2 and 3 are connected within relay. Run capacitor is connected to relay terminal 3. L2 side of 120 VAC power is connected to relay terminal 2.</p>	<ol style="list-style-type: none"> 1. Disconnect power to the refrigerator. 2. Remove relay cover and disconnect leads. 3. Check resistance across terminals 2 and 3 with an ohmmeter: Normal = 3 to 12 ohms Shorted = 0 ohms Open = infinite ohms
<p>Control board</p> 	<p>On some models.</p> <p>See "Control Board" section for troubleshooting information.</p>	
<p>Ice maker</p>	<p>Optional on some models.</p> <p>See "Ice Maker" section for service information.</p>	
<p>Evaporator fan motor</p> 	<p>Evaporator fan moves air across evaporator coil and throughout refrigerator cabinet.</p>	<ol style="list-style-type: none"> 1. Disconnect power to unit. 2. Disconnect fan motor leads. 3. Check resistance from ground connection solder. Trace to motor frame must not exceed .05 ohms. 4. Check for voltage at connector to motor with unit in refrigeration mode and compressor operating.
<p>Electric damper control</p> 	<p>Damper control balances the air delivery between refrigerator and freezer compartments providing temperature control for refrigerator.</p> <p>Electrical voltage activates damper control and door closes restricting flow of air from freezer compartment to refrigerator compartment.</p>	<p>Check resistance across terminals.</p> <p>If no resistance across terminals replace damper control.</p>

Component Testing



WARNING

To avoid risk of electrical shock, personal injury, or death, disconnect electrical power source to unit, unless test procedures require power to be connected. Discharge capacitor through a resistor before attempting to service. Ensure all earthing wires are connected before certifying unit as repaired and/or operational.

Component	Description	Test Procedures
Switch, refrigerator light, 	Single pole, single throw switch completes circuit for light when door is open.	Check resistant across terminals. Switch arm depressed "NO" terminals Open Switch arm up "NO" terminals Closed
Switch, freezer light 	Single pole, double throw switch completes circuit for light when door is open. Opens circuit to icemaker when door is open.	Check resistant across terminals. Switch arm depressed "NO" terminals Open "NC" terminals Closed Switch arm up "NO" terminals Closed "NC" terminals Open
Switch, water dispenser	Single pole, single throw switch completes circuit for water solenoid when button is depressed.	Check resistant across terminals. Water button not depressed "NO" terminals Open Water button depressed "NO" terminals Closed
Drier 	Drier is placed at post condenser loop outlet and passes liquefied refrigerant to capillary. Desiccant (20) 8 x 12 4AXH - 7 M>S> - Grams	<p>Drier must be changed every time the system is opened for testing or compressor replacement.</p> <p>NOTE: Drier used in R12 sealed system is not interchangeable with drier used in R134a sealed system. Always replace drier in R134a system with Amana part number B2150504.</p> <p>Before opening refrigeration system, recover HFC134a refrigerant for safe disposal.</p> <ol style="list-style-type: none"> 1. Cut drier out of system using the following procedure. Do not unbrazed drier. 2. Applying heat to remove drier will drive moisture into the system. 3. Score capillary tube close to drier and break. 4. Reform inlet tube to drier allowing enough space for large tube cutter. 5. Cut circumference of drier 31.75 mm below condenser inlet tube joint to drier. 6. Remove drier. 7. Apply heat trap paste on post condenser tubes to protect grommets from high heat. 8. Unbrazed remaining part of drier. Remove drier from system. 9. Discard drier in safe place. Do not leave drier with customer. If refrigerator is under warranty, old drier must accompany warranty claim.



WARNING



To avoid death or severe personal injury, cut drier at correct location. Cutting drier at incorrect location will allow desiccant beads to scatter. If spilled, completely clean area of beads.

Component Testing

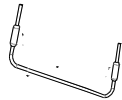
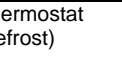
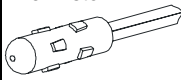

WARNING

To avoid risk of electrical shock, personal injury, or death, disconnect electrical power source to unit, unless test procedures require power to be connected. Discharge capacitor through a resistor before attempting to service. Ensure all earthing wires are connected before certifying unit as repaired and/or operational.

Component	Description	Test Procedures								
Evaporator	<p>Inner volume of evaporator allows liquid refrigerant discharged from capillary to expand into refrigerant gas.</p> <p>Expansion cools evaporator tube and fin temperature to approximately -20°F transferring heat from freezer section to refrigerant.</p> <p>Passing through suction line to compressor, the refrigerant picks up superheat (a relationship between pressure and temperature that assures complete vaporization of liquid refrigerant) as the result of capillary tube soldered to suction line.</p> <p>Refrigerant gas is pulled through suction line by compressor, completing refrigeration cycle.</p>	<p>Test for leaks in evaporator with electronic leak detector or with soap solution. Compressor oil is circulated with refrigerant; check for oil when checking for leaks.</p> <p>For minute leaks:</p> <ol style="list-style-type: none"> 1. Separate evaporator from rest of refrigeration system and pressurize evaporator up to a maximum of 9.65 Bar with a refrigerant and dry nitrogen combination. 2. Recheck for leaks. 								
	<p>Activated when defrost thermostat, defrost timer, and freezer control complete circuit through heater.</p>	<p>Check resistance across heater.</p> <p>To check defrost system:</p> <ol style="list-style-type: none"> 1. Thermocouple defrost thermostat and plug refrigerator into wattmeter. 2. Turn into defrost mode. Wattmeter should read specified watts (according to Technical Data Sheet). 3. When defrost thermostat reaches specified temperature $\pm 15^{\circ}\text{C}$ (see Technical Data Sheet), thermostat should interrupt power to heater. 								
	<p>Thermostat is in a series circuit with terminal 2 of defrost timer, and defrost heater. Circuit is complete if evaporator fan motor operates when cold.</p> <p>Controls the circuit from freezer thermostat through defrost terminator to defrost heater. Opens and breaks circuit when thermostat senses preset high temperature.</p>	<p>Test continuity across terminals.</p> <p>With power off and evaporator coil below freezing, thermostat should show continuity when checked with ohmmeter. See "Heater, evaporator (defrost)" section for additional tests.</p> <p>After defrost thermostat opens, thermostat remains open until end of defrost cycle and refrigerator starts cooling again. Defrost thermostat senses a preset low temperature and resets (closes).</p>								
	<p>Temperature sensing device</p>	<p>Check resistance across leads.</p> <table border="1"> <thead> <tr> <th>Temperature</th> <th>Resistance</th> </tr> </thead> <tbody> <tr> <td>25°C</td> <td>10,000 ohms</td> </tr> <tr> <td>2.2°C</td> <td>29,500 ohms</td> </tr> <tr> <td>-17.7°C</td> <td>86,300 ohms</td> </tr> </tbody> </table>	Temperature	Resistance	25°C	10,000 ohms	2.2°C	29,500 ohms	-17.7°C	86,300 ohms
Temperature	Resistance									
25°C	10,000 ohms									
2.2°C	29,500 ohms									
-17.7°C	86,300 ohms									
	<p>Condenser fan moves cooling air across condenser coil and compressor body.</p> <p>Condenser fan motor is in parallel circuit with compressor.</p>	<p>Check resistance across coil.</p>								
	<p>Condenser fan moves cooling air across condenser coil and compressor body.</p> <p>Condenser fan motor is in parallel circuit with compressor.</p>	<p>Check resistance across coil.</p>								



WARNING

To avoid severe personal injury or death from sudden eruption of high pressures gases, observe the following:
 Protect against a sudden eruption if high pressures are required for leak checking.
 Do not use high pressure compressed gases in refrigeration systems without a reliable pressure regulator and pressure relief valve in the lines.

Service Procedures



WARNING

To avoid risk of electrical shock, personal injury, or death, disconnect electrical power source to unit, unless test procedures require power to be connected. Discharge capacitor through a resistor before attempting to service. Ensure all earthing wires are connected before certifying unit as repaired and/or operational.

Service Equipment

Listed below is equipment needed for proper servicing of HFC134a systems. Verify equipment is confirmed by manufacturer as being compatible with HFC134a and ester oil system.

Equipment must be exclusively used for HFC134a. Exclusive use of equipment only applies to italic items.

- **Evacuation pump**

Check with vacuum pump supplier to verify equipment is compatible for HFC134a. Robinair, Model 15600 2 stage, 6 cubic feet per minute pump is recommended.

- ***Four-way manifold gauge set, with low loss hoses***

- **Leak detector**

- ***Charging cylinder***

- ***Line piercing saddle valve***

(Schroeder valves). Seals must be HFC134a and ester oil compatible. Line piercing valves may be used for diagnosis but are not suitable for evacuation or charging, due to minute holes pierced in tubing. Do not leave mechanical access valves on system.

Valves eventually will leak. Molecules of HFC134a are smaller than other refrigerants and will leak where other refrigerants would not.

- ***Swagging tools***

- ***Flaring tools***

- ***Tubing cutter***

- **Flux**

- **Sil-Fos**

- **Silver solder**

- ***Oil for swagging and flaring***

Use only part # R0157532

- ***Copper tubing***

Use only part # R0174075 and # R0174076

- **Dry nitrogen**

99.5% minimum purity, with -40°C or lower dew point

- **Crimp tool**

- **Tube bender**

- **Micron vacuum gauge**

- ***Process tube adaptor kit***

- **Heat trap paste**

- ***ICI appliance grade HFC134a***

Drier Replacement

Before opening refrigeration system, recover HFC134a refrigerant for safe disposal.

Every time sealed HFC134a system is repaired, drier filter must be replaced with, part # B2150504.

Cut drier out of system by completing the following steps. Do not unbraid drier filter. Applying heat to remove drier will drive moisture into system.



WARNING

To avoid risk of severe personal injury or death, cut drier at correct location. Cutting drier at incorrect location will allow desiccant beads to scatter. Completely clean area of beads, if spilled.

1. Score capillary tube close to drier and break.
2. Reform inlet tube to drier allowing enough space for large tube cutter.
3. Cut circumference of drier at 31.75 millimeters, below condenser inlet tube joint to drier.
4. Remove drier.
5. Apply heat trap paste on post condenser tubes to protect grommets from high heat.
6. Unbraid remaining part of drier. Remove drier from system.
7. Discard drier in safe place. Do not leave drier with customer. If refrigerator is under warranty, old drier must accompany warranty claim.

Service Procedures



WARNING

To avoid risk of electrical shock, personal injury, or death, disconnect electrical power source to unit, unless test procedures require power to be connected. Discharge capacitor through a resistor before attempting to service. Ensure all earthing wires are connected before certifying unit as repaired and/or operational.

Refrigerant Precautions



WARNING

To avoid risk of personal injury, do not allow refrigerant to contact eyes or skin.



CAUTION

To avoid risk of property damage, do not use refrigerant other than that shown on unit serial number identification plate.

NOTE: All precautionary measures recommended by refrigerant manufacturers and suppliers apply and should be observed.

Line Piercing Valves

Line piercing valves can be used for diagnosis, but are not suitable for evacuating or charging due to holes pierced in tubing by valves.

NOTE: Do not leave line piercing valves on system. Connection between valve and tubing is not hermetically sealed. Leaks will occur.

Open Lines

During any processing of refrigeration system, never leave lines open to atmosphere. Open lines allow water vapor to enter system, making proper evacuation more difficult.

Compressor Operational Test

(short term testing only)

If compressor voltage, capacitor, overload, and motor winding tests are successful (do not indicate a fault), perform the following test:

1. Disconnect power to unit.
 2. Discharge capacitor by shorting capacitor terminals through a resistor.
- NOTE:** Not all units have run capacitor.
3. Remove leads from compressor terminals.
 4. Attach test cord to compressor windings.
 - Common lead on test cord attaches to C terminal on compressor.
 - Start lead on test cord attaches to S terminal on compressor.
 - Run lead on test cord attaches to M terminal on compressor.

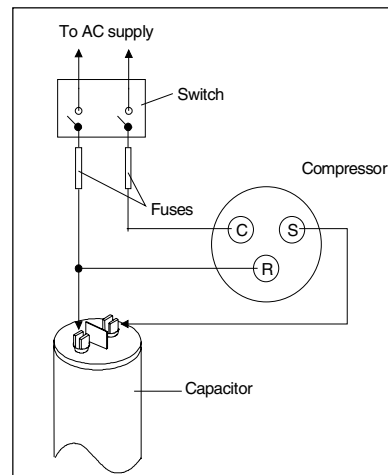

Attaching Capacitor for Compressor Test

5. Connect a known good capacitor into circuit as shown above. For proper capacitor size and rating, see technical data sheet for unit under test.

NOTE: Ensure test cord cables and fuses meet specifications for unit under test (see Technical Sheet for unit under test).

6. Replace compressor protector cover securely.
7. Plug test cord into outlet, then press and release start cord switch.



CAUTION

To avoid risk of damage to compressor windings, immediately disconnect (unplug) test cord from power source if compressor does not start. Damage to compressor windings occurs if windings remain energized when compressor is not running.

If compressor runs when direct wired, it is working properly. Malfunction is elsewhere in system.

If compressor does not start when direct wired, recover system at high side. After the system is recovered, repeat compressor direct wire test.

If compressor runs after system is recovered (but would not operate when wired direct before recovery) a restriction in sealed system is indicated.

If motor does not run when wired direct after recovery, replace faulty compressor.

Service Procedures



WARNING

To avoid risk of electrical shock, personal injury, or death, disconnect electrical power source to unit, unless test procedures require power to be connected. Discharge capacitor through a resistor before attempting to service. Ensure all earthing wires are connected before certifying unit as repaired and/or operational.

Dehydrating Sealed Refrigeration System

Moisture in a refrigerator sealed system exposed to heat generated by the compressor and motor reacts chemically with refrigerant and oil in the system and forms corrosive hydrochloric and hydrofluoric acids. These acids contribute to breakdown of motor winding insulation and corrosion of compressor working parts, causing compressor failure.

In addition, sludge, a residue of the chemical reaction, coats all surfaces of sealed system, and will eventually restrict refrigerant flow through capillary tube.

To dehydrate sealed system, evacuate system (see paragraph *Evacuation*).

Leak Testing



DANGER

To avoid risk of serious injury or death from violent explosions, NEVER use oxygen or acetylene for pressure testing or clean out of refrigeration systems. Free oxygen will explode on contact with oil. Acetylene will explode spontaneously when put under pressure.

It is important to check sealed system for refrigerant leaks. Undetected leaks can lead to repeated service calls and eventually result in system contamination, restrictions, and premature compressor failure.

Refrigerant leaks are best detected with halide or electronic leak detectors.

Testing Systems Containing a Refrigerant Charge

1. Stop unit operation (turn refrigerator off).
2. Holding leak detector exploring tube as close to system tubing as possible, check all piping, joints, and fittings.

NOTE: Use soap suds on areas leak detector cannot reach or reliably test.

Testing Systems Containing No Refrigerant Charge

1. Connect cylinder of nitrogen, through gauge manifold, to process tube of compressor and liquid line strainer.
2. Open valves on nitrogen cylinder and gauge manifold. Allow pressure to build within sealed system.
3. Check for leaks using soap suds.

If a leak is detected in a joint, do not to attempt to repair by applying additional brazing material. Joint must be disassembled, cleaned and rebrazed. Capture refrigerant charge (if system is charged), unbrazed joint, clean all parts, then rebraze.

If leak is detected in tubing, replace tubing. If leak is detected in either coil, replace faulty coil.

Service Procedures



WARNING

To avoid risk of electrical shock, personal injury, or death, disconnect electrical power source to unit, unless test procedures require power to be connected. Discharge capacitor through a resistor before attempting to service. Ensure all earthing wires are connected before certifying unit as repaired and/or operational.

Restrictions

Symptoms

Restrictions in sealed system most often occur at capillary tube or filter drier, but can exist anywhere on liquid side of system.

Restrictions reduce refrigerant flow rate and heat removal rate. Wattage drops because compressor is not circulating normal amount of refrigerants.

Common causes of total restrictions are moisture, poorly soldered joints, or solid contaminants. Moisture freezes at evaporator inlet end of capillary tube. Solid contaminants collect in filter drier.

If restriction is on low side, suction pressure will be in a vacuum and head pressure will be near normal.

If restriction is on high side, suction pressure will be in a vacuum and head pressure will be higher than normal during pump out cycle.

Refrigeration occurs on low pressure side of partial restriction. There will be a temperature difference at the point of restriction. Frost and/or condensation will be present in most case at the point of restriction. Also, system requires longer to equalize.

Slight or partial restriction can give the same symptoms as refrigerant shortage including lower than normal back pressure, head pressure, wattage, and warmer temperatures.

Total restriction on the discharge side of compressor, when restriction is between compressor and first half of condenser, results in higher than normal head pressure and wattage while low side is being pumped out.

Testing for Restrictions

To determine if a restriction exists:

1. Attach gauge and manifold between suction and discharge sides of sealed system.
2. Turn unit on and allow pressure on each side to stabilize. Inspect condenser side of system. Tubing on condenser should be warm and temperature should be equal throughout (no sudden drops at any point along tubing).
 - If temperature of condenser tubing is consistent throughout, go to step 4.
 - If temperature of condenser tubing drops suddenly at any point, tubing is restricted at point of temperature drop (if restriction is severe, frost may form at point of restriction and extend down in direction of refrigerant flow in system). Go to step 5.

3. Visually check system for kinks in refrigeration line which is causing restriction. Correct kink and repeat step 2.
 4. Turn unit off and time how long it takes high and low pressure gauges to equalize:
 - If pressure equalization takes longer than 10 minutes, a restriction exists in the capillary tube or drier filter. Go to step 5.
 - If pressure equalization takes less than 10 minutes, system is not restricted. Check for other possible causes of malfunction.
 5. Recover refrigerant in sealed system.
- NOTE:** Before opening any refrigeration system, capture refrigerant in system for safe disposal.
6. Remove power from unit.



CAUTION

To avoid risk of personal injury or property damage, take necessary precautions against high temperatures required for brazing.

7. Remove and replace restricted device.
 8. Evacuate sealed system.
 9. Charge system to specification.
- NOTE:** Do not use captured or recycled refrigerant in units. Captured or recycled refrigerant voids any compressor manufacturer's warranty.
- NOTE:** Charge system with exact amount of refrigerant. Refer to unit nameplate for correct refrigerant charge. Inaccurately charged system will cause future problems.

Service Procedures



WARNING

To avoid risk of electrical shock, personal injury, or death, disconnect electrical power source to unit, unless test procedures require power to be connected. Discharge capacitor through a resistor before attempting to service. Ensure all earthing wires are connected before certifying unit as repaired and/or operational.

Evacuation and Charging



CAUTION

To avoid risk of fire, sealed refrigeration system must be air free. To avoid risk of air contamination, follow evacuation procedures exactly.

NOTE: Before opening any refrigeration system, EPA regulations require refrigerant in system to be captured for safe disposal.

Proper evacuation of sealed refrigeration system is an important service procedure. Usable life and operational efficiency greatly depends upon how completely air, moisture and other non-condensables are evacuated from sealed system.

Air in sealed system causes high condensing temperature and pressure, resulting in increased power requirements and reduced performance.

Moisture in sealed system chemically reacts with refrigerant and oil to form corrosive hydrofluoric and hydrochloric acids. These acids attack motor windings and parts, causing premature breakdown.

Before opening system, evaporator coil must be at ambient temperature to minimize moisture infiltration into system.

Evacuation

To evacuate sealed refrigeration system:

1. Connect vacuum pump, vacuum tight manifold set with high vacuum hoses, thermocouple vacuum gauge and charging cylinder as shown in illustration. Evacuation should be done through I.D. opening of tubes not through line piercing valve.
2. Connect low side line to compressor process tube.
3. Connect high side line to drier/process tube.
4. Evacuate both simultaneously. With valve "C" and "F" closed, open all other valves and start vacuum pump.

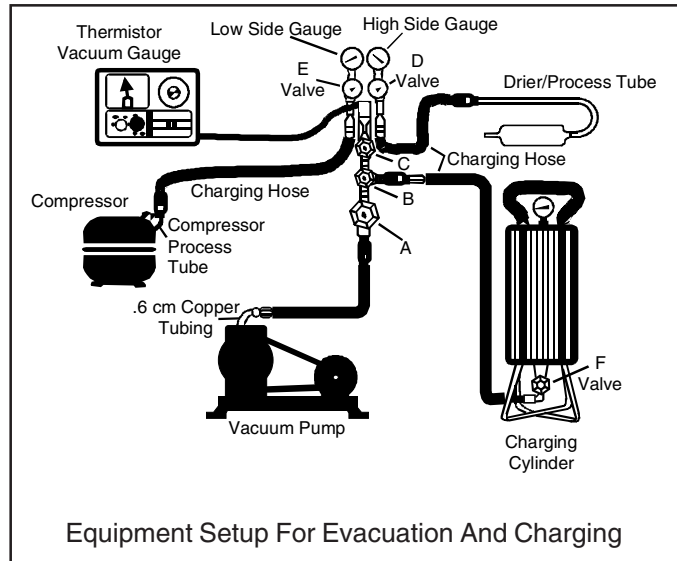

Equipment Setup For Evacuation And Charging

5. After compound gauge (low side) drops to approximately .98 Bar, open valve "C" to vacuum thermocouple gauge and take micron reading.

NOTE: A high vacuum pump can only produce a good vacuum if oil in pump is not contaminated.

6. Continue evacuating system until vacuum gauge registers 600 microns.
7. At 600 microns, close valve "A" to vacuum pump and allow micron reading in system to balance. Micron level will rise.
 - If in 2 minutes, micron level stabilizes at 1000 microns or below, system is ready to be charged.
 - If micron level rises above 1000 microns and stabilizes, open valve "A" and continue evacuating.
 - If micron reading rises rapidly and does not stabilize, a leak still exists in system.Close valve "A" to vacuum pump and valve "C" to vacuum gauge. Invert charging cylinder and open charging cylinder valve "F" to add partial charge for leak checking. With leak detector, check manifold connections and system for leaks. After locating leak, capture refrigerant, repair leak, and begin at step 1.

Service Procedures



WARNING

To avoid risk of electrical shock, personal injury, or death, disconnect electrical power source to unit, unless test procedures require power to be connected. Discharge capacitor through a resistor before attempting to service. Ensure all earthing wires are connected before certifying unit as repaired and/or operational.

Charging

NOTE: Do not use captured or recycled refrigerant in units. Captured or recycled refrigerant voids any warranty.

NOTE: Charge system with exact amount of refrigerant. Refer to unit serial plate for correct refrigerant charge. Inaccurately charged system will cause future problems.

To charge system:

1. Close valves "A" to vacuum pump and "C" to vacuum gauge and "E" to low side manifold gauge.
2. Set scale on dial-a-charge cylinder for corresponding HFC134a pressure reading.
3. Open valve "F" to charging cylinder and let exact amount of refrigerant flow from cylinder into system. Close valve.
Low side gauge pressure should rise shortly after opening charging cylinder valve as system pressure equalizes through capillary tube.
If pressure does not equalize, a restriction typically exists at capillary/drier braze joint.
4. If pressure equalizes, open valve "E" to low side manifold gauge and pinch off high side drier process tube.
5. Start compressor and draw remaining refrigerant from charging hoses and manifold into compressor through compressor process tube.
6. To check high side pinch-off drier process tube. Close valve "D" to high side gauge. If high side pressure rises, repeat high side pinch-off and open valve "D". Repeat until high side pinch-off does not leak.
7. Pinch-off compressor process tube and remove charging hose. Braze stub closed while compressor is operating.
8. Disconnect power. Remove charging hose and braze high side drier process tube closed.
9. Recheck for refrigerant leaks.

Refrigerant Charge

Refrigerant charge in all capillary tube systems is critical and exact amount is required for proper performance. Factory charges are shown on serial plate.

NOTE: Do not use refrigerant other than shown on serial plate.

Service Procedures



WARNING

To avoid risk of electrical shock, personal injury, or death, disconnect electrical power source to unit, unless test procedures require power to be connected. Discharge capacitor through a resistor before attempting to service. Ensure all earthing wires are connected before certifying unit as repaired and/or operational.

HFC134a Service Information

HFC134a is alternative refrigerant for CFC12. HFC134a has an ozone depletion potential (ODP) factor of 0.0 and a global warming potential (GWP) factor of 0.27. HFC134a is not flammable and has acceptable toxicity levels. HFC134a is not interchangeable with CFC12. There are significant differences between HFC134a and CFC12 which must be considered when handling and processing refrigeration system.

Health, Safety, and Handling

Health, safety and handling considerations for HFC134A are virtually no different than those for CFC12.

Health, Safety, and Handling	CFC12	HFC134a
Allowable overall exposure limit	1,000 ppm	Same
Vapor exposure to skin	No effect	Same
Liquid exposure to skin	Can cause frostbite	Same
Vapor exposure to eye	Very slight eye irritant	Same
Liquid exposure to eye	Can cause frostbite	Same
Above minimum exposure limit	Can cause Asphyxiation, Tachycardia, and Cardia Arrhythmias	Same
Safety and handling	Wear appropriate skin and eye protection. Use with adequate ventilation.	Same
Spill management	Remove or extinguish ignition or combustion sources. Evacuate or ventilate area.	Same
Fire explosion hazards	May decompose if contact with flames and heating elements. Container may explode if heated due to resulting pressure rise. Combustion products are toxic.	Same
Disposal procedures	Recycle or reclaim.	Same

Comparison of CFC12 and HFC134a Properties

Properties/Characteristics	CFC12	HFC134a
Ozone Depletion Potential (ODP)	1.0*	0.0*
Global Warming Potential (GPW)	3.2*	0.27*
Molecular weight	121	102
Boiling point at 1 atmosphere	-22°F (-30°C)	-15°F (-126°C)
Vapor pressure at 77°F (25°C)	80 psig	82 psig
Liquid density at 77°F (25°C)	82 lb/ft ³	75 lb/ft ³
Flammability	No	No
High-side system operating Pressure at 65°F (18°C)	HFC134a approximately 3 psig higher than CFC12	
Low-side system operating Pressure at 65°F (18°C)	HFC134a approximately 2 psig lower than CFC12	



CAUTION

To minimize contamination, exercise extreme care when servicing HFC134A sealed systems.

- No trace of other refrigerants is allowed in HFC134a systems. Chlorinated molecules in other refrigerants such as CFC12, etc. will lead to capillary tube plugging.
- Ester oil is used in HFC134a systems. Do not use mineral oil. HFC134a and mineral oils cannot be mixed. If mineral oils were used in HFC134a systems, lubricant would not return to compressor and would cause early compressor failure. If significant amount of oil has been lost from compressor, replace oil rather than adding oil.
- Ester oils used in HFC134a systems are so hydroscopic that by the time an inadequate system performance is detected, oil will be saturated with moisture.
- CFC12 has much higher tolerance to system processing materials, such as drawing compounds, rust inhibitors, and cleaning compounds, than HFC134a. Such materials are not soluble in HFC134a systems. If materials were to be washed from system surfaces by ester oils, they could accumulate and eventually plug capillary tube.
- Care must be taken to minimize moisture entering HFC134a system. Do not leave compressor or system open to atmosphere for more than 10 minutes. Excessive moisture in HFC134a system will react with compressor oil and generate acid.
- Compressor must be replaced when performing low side leak repair.
- Drier filter must always be replaced with service drier filter, part #B2150504.

Important: Unbrazing drier filter from tubing will drive moisture from desiccant and into system, causing acids to form. Do not unbrazed filter drier from tubing. If CFC12 service drier was installed in HFC134A system, drier could overload due to excessive moisture.

- HFC134a compatible copper tubing, part #R0174075 .635 millimeter x 457.2 millimeter length and part #R0174076 7.93 millimeter x 609.6 millimeter must be used when replacing tubing.
- Avoid system contamination by using Towerdraw E610 evaporating oil, part # R0157532, when flaring, swagging, or cutting refrigeration tubing.

Service Procedures



WARNING

To avoid risk of electrical shock, personal injury, or death, disconnect electrical power source to unit, unless test procedures require power to be connected. Discharge capacitor through a resistor before attempting to service. Ensure all earthing wires are connected before certifying unit as repaired and/or operational.

Replacement Service Compressor

HFC134a service compressors will be charged with ester oil and pressurized with dry nitrogen. Before replacement compressor is installed, pull out 1 rubber plug. A *pop* from pressure release should be heard. If a *pop* sound is not heard, do not use compressor. Positive pressure in compressor is vital to keep moisture out of ester oil. Do not leave compressor open to atmosphere for more than 10 minutes.

Compressor Testing Procedures



WARNING

To avoid death or severe personal injury, never use oxygen, air or acetylene for pressure testing or clean out of refrigeration system. Use of oxygen, air, or acetylene may result in violent explosion. Oxygen may explode on contact with oil and acetylene will spontaneously explode when under pressure.

Refer to Technical Data Sheet "Temperature Relationship Chart" for operating watts, test points, and temperature relationship test for unit being tested.

- Temperature testing is accomplished by using 3 lead thermocouple temperature tester in specific locations. Test point T-1 is outlet on evaporator coil and T-2 is inlet. Test point T-3 is suction tube temperature midway between where armaflex ends and suction port of compressor (approximately 304.8 millimeters from compressor).
- Thermocouple tips should be attached securely to specified locations.
- Do not test during initial *pull down*. Allow one off cycle or balanced temperature condition to occur before proceeding with testing.
- Refrigerator must operate minimum of 20 minutes after thermocouples are installed.
- Turn control to colder to obtain required on time.
- Wattage reading must be recorded in conjunction with temperature test to confirm proper operation.
- Suction and head pressures are listed on "Temperature and Relationship Chart". Normally these are not required for diagnosis but used for confirmation on systems which have been opened.

Brazing



CAUTION

To avoid risk of personal injury or property damage, take necessary precautions against high temperatures required for brazing.

Satisfactory results require cleanliness, experience, and use of proper materials and equipment.

Connections to be brazed must be properly sized, free of rough edges, and clean.

Generally accepted brazing materials are:

- **Copper to copper joints:** SIL-FOS (alloy of 15 percent silver, 80 percent copper, and 5 percent phosphorous). Use without flux. Recommended brazing temperature is approximately 760°C. **Do not use for copper to steel connection.**
- **Copper to steel joints:** SILVER SOLDER (alloy of 30 percent silver, 38 percent copper, 32 percent zinc). Use with fluoride based flux. Recommended brazing temperature is approximately 649°C.
- **Steel to steel joints:** SILVER SOLDER (see copper to steel joints).
- **Brass to copper joints:** SILVER SOLDER (see copper to steel joints).
- **Brass to steel joints:** SILVER SOLDER (see copper to steel joints).

Refrigerant Flow

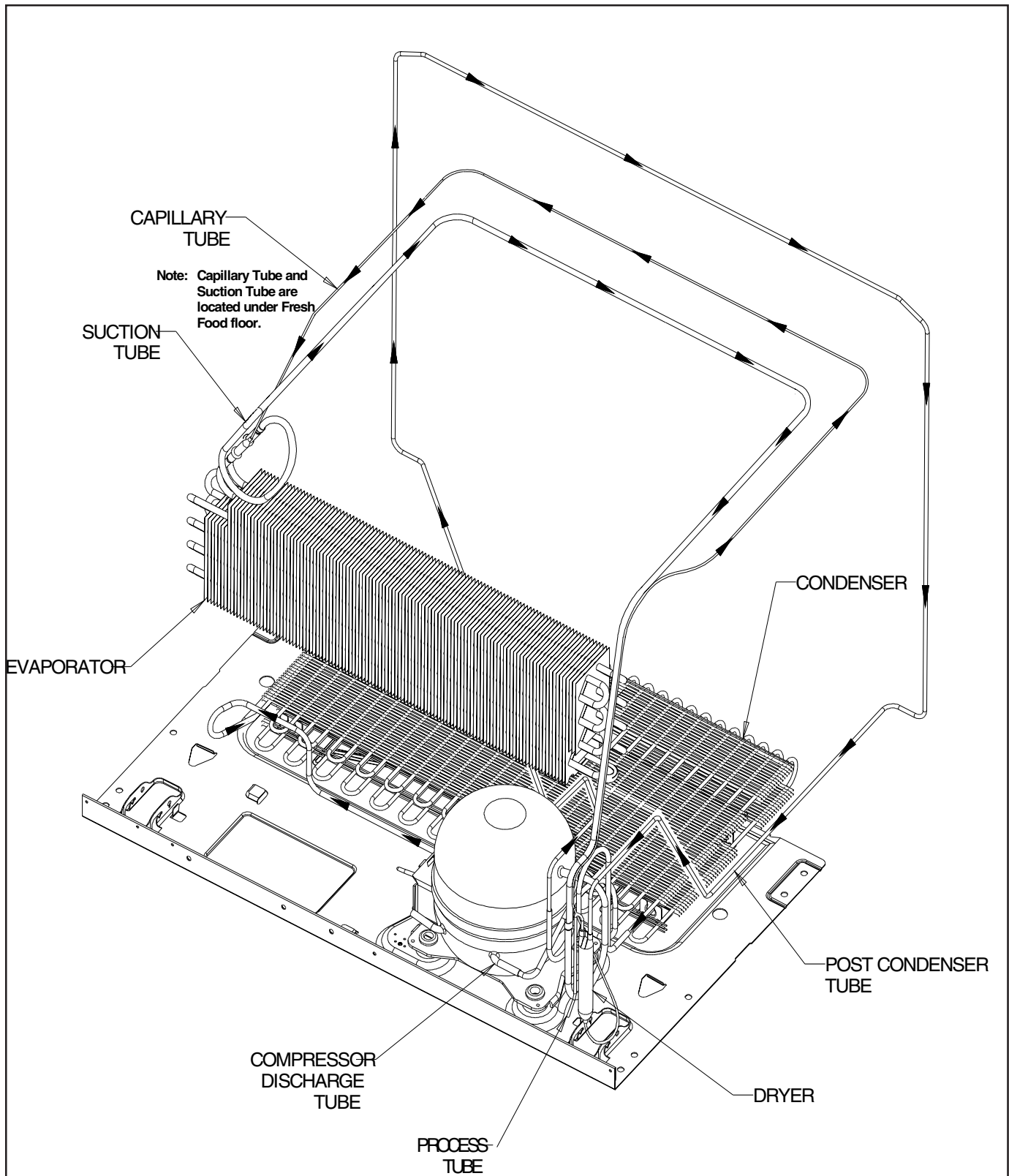

**Bottom Mount
Refrigerant Flow Diagram**

Cabinet Air Flow

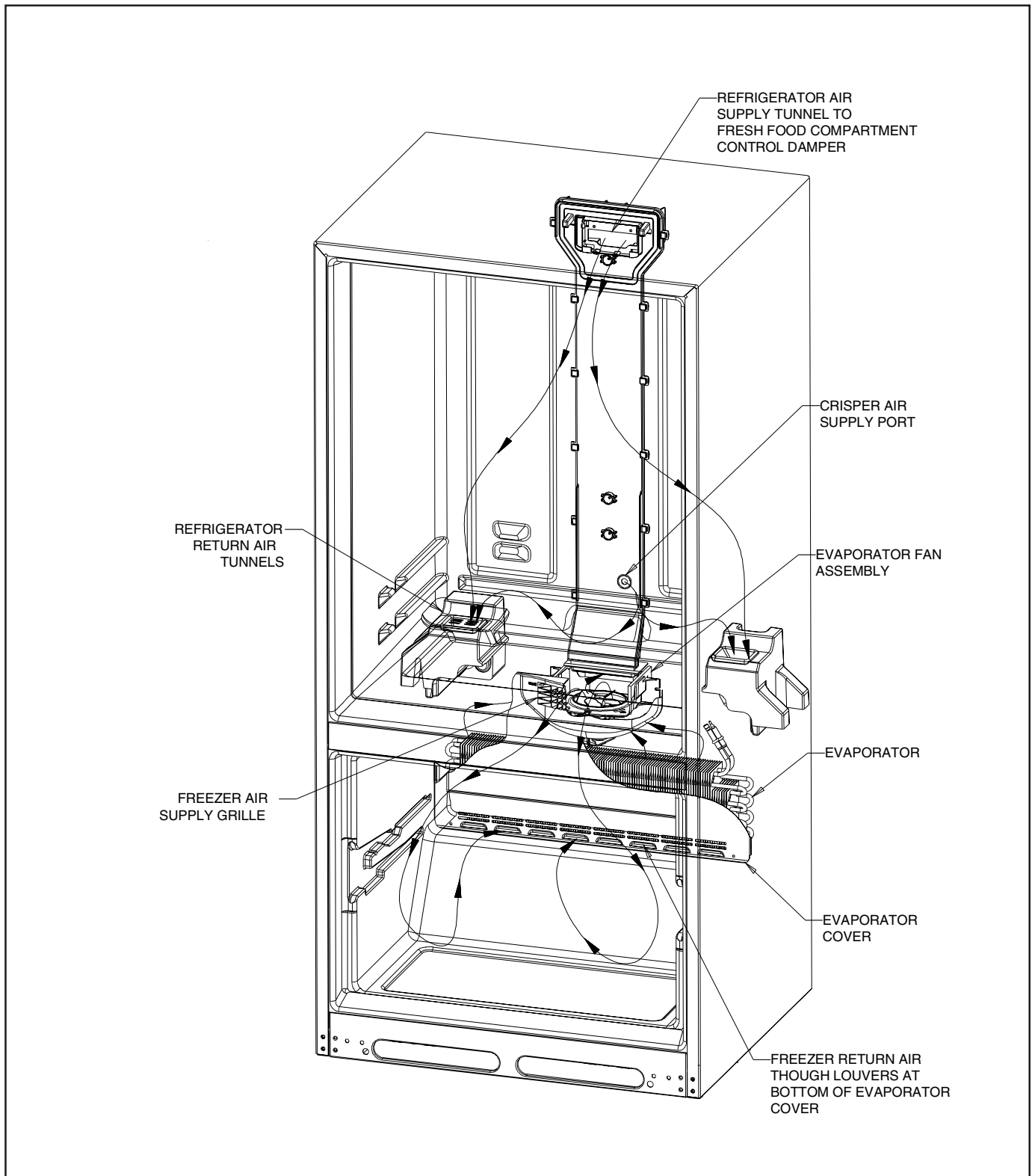

**Bottom Mount
Cabinet Air Flow Diagram**

Machine Compartment Air Flow

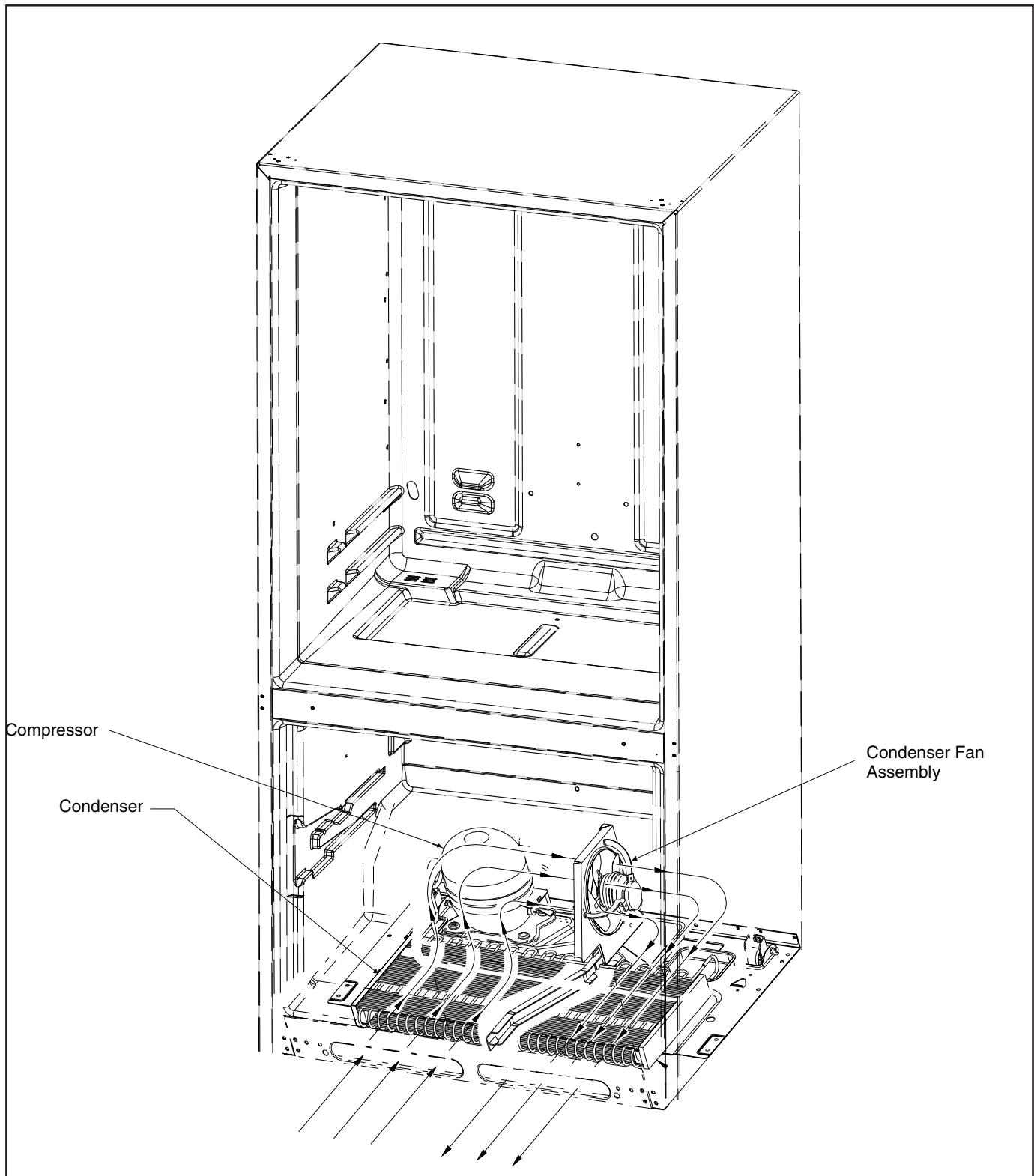

**Two Way Bottom Mount
Machine Compartment Air Flow Diagram**

Machine Compartment Air Flow

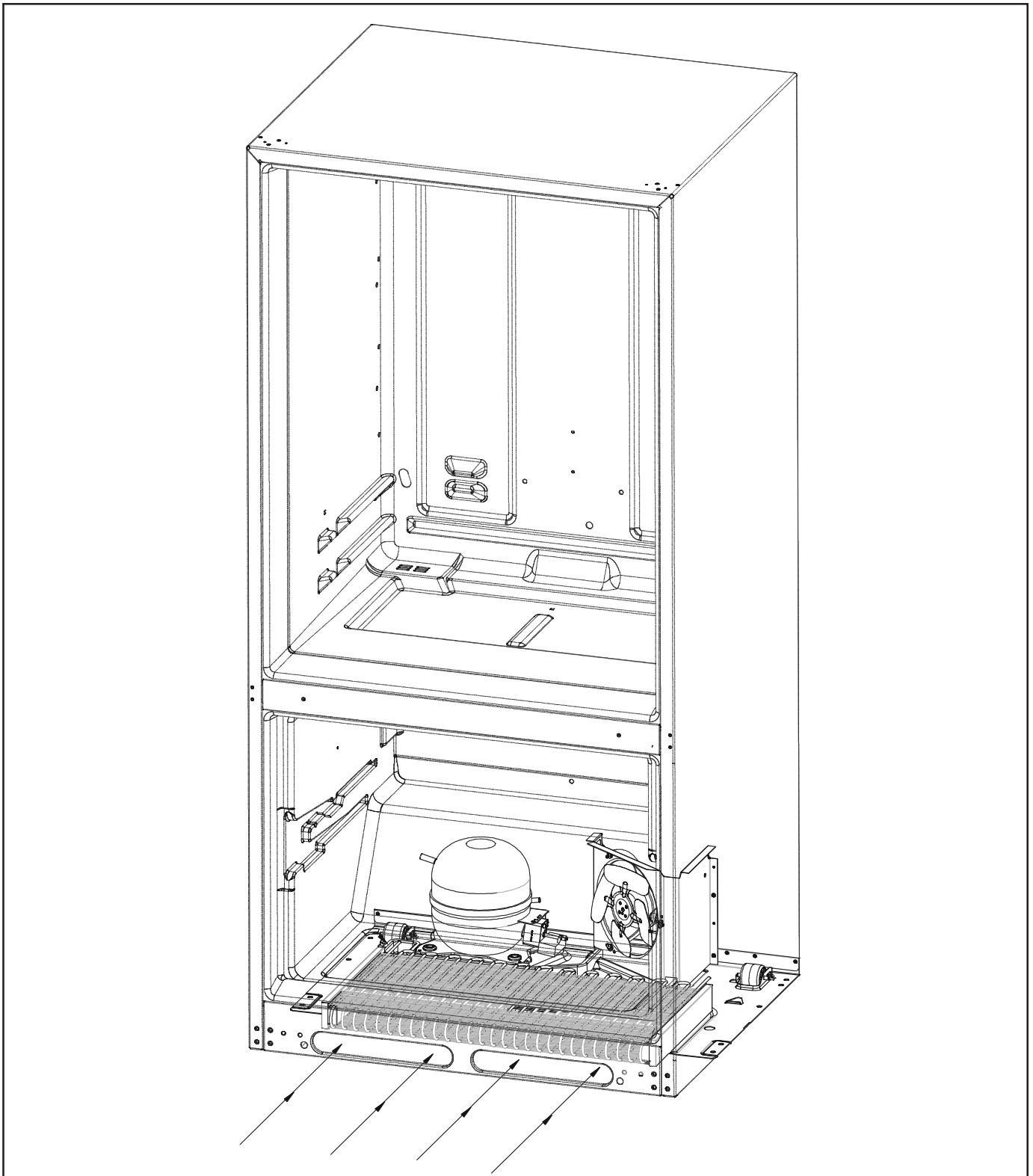

**One Way Bottom Mount
Machine Compartment Air Flow Diagram**

Typical External Sweat Pattern

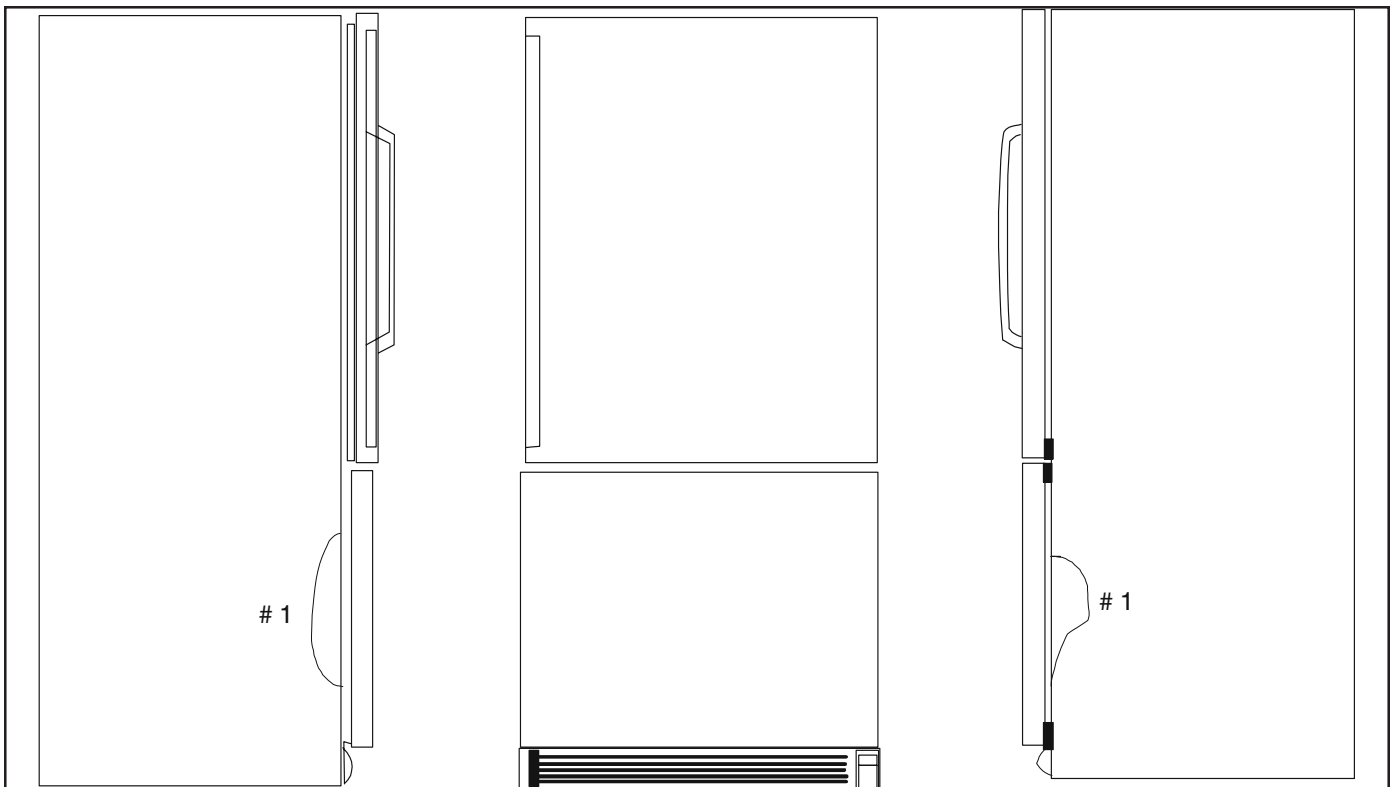

CLASSIFICATION OF CONDENSATION

- 1 = Haze or fog
- 2 = Beading
- 3 = Beads or small drops
- 4 = Drops running together

Conditions after 4 hour
Laboratory Sweat Test.
Ambient: 90 dF
Relative humidity 84%
Refrigerator Temp. 40 dF
Freezer Temp. 0 dF

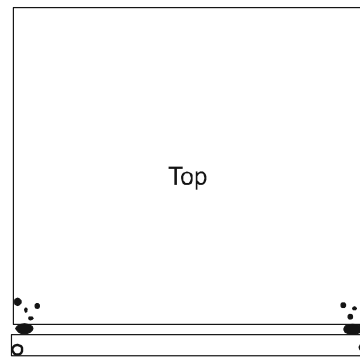
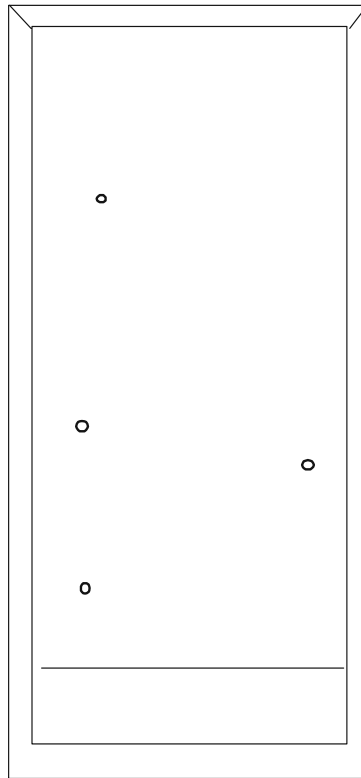

Refrigerator door bottom

No sweat on side when compressor is running

1

Center mullion

2

Freezer door top

Freezer door bottom

2

Lower mullion

Troubleshooting Chart



WARNING

To avoid risk of electrical shock, personal injury, or death, disconnect electrical power source to unit, unless test procedures require power to be connected. Discharge capacitor through a resistor before attempting to service. Ensure all earthing wires are connected before certifying unit as repaired and/or operational.

Troubleshooting chart on following pages contains symptoms that may be seen in malfunctioning units. Each symptom is accompanied by one or more possible causes and by a possible remedy or test to determine if components are working properly.

Symptom	Possible Causes	Corrective Action
Unit does not run	No power to unit	Check for power at outlet. Check fuse box/circuit breaker for blown fuse or tripped breaker. Replace or reset.
	Faulty power cord	Check with test light at unit; if no circuit and current is indicated at outlet, replace or repair.
	Low voltage	Check input voltage for proper voltage. Take appropriate action to correct voltage supply problem.
	Faulty motor	Check all connections are tight and secure. Jumper across terminals of control. If unit runs, replace control.
	Faulty relay	Check relay. Replace if necessary.
	Faulty compressor	Check compressor motor windings for opens/shorts. Perform compressor direct wiring test. Replace if necessary.
	Faulty overload	Check overload for continuity. NOTE: Ensure compressor/overload are below trip temperature before testing. Replace if necessary.
Refrigerator section too warm	Excessive door opening	Consumer education
	Overloading of shelves	Consumer education
	Warm or hot foods placed in cabinet	Consumer education
	Cold control set too warm	Set control to colder setting.
	Poor door seal	Level cabinet. Adjust hinges. Replace gasket.
	Refrigerator airflow	Check damper is opening by removing grille. With door open, damper should open. Replace if faulty. Turn control knob to colder position.
	Interior light remains on	Check switch. Replace if necessary.
	Faulty condenser fan or evaporator fan	Check fan and wiring. Replace if necessary.
	Faulty compressor	Replace compressor.

Troubleshooting Chart



WARNING

To avoid risk of electrical shock, personal injury, or death, disconnect electrical power source to unit, unless test procedures require power to be connected. Discharge capacitor through a resistor before attempting to service. Ensure all earthing wires are connected before certifying unit as repaired and/or operational.

Symptom	Possible Causes	Corrective Action
Refrigerator section too cold	Refrigerator temperature control set too cold	Adjust refrigerator temperature control.
	Refrigerator airflow not properly adjusted	Check air flow.
Freezer and refrigerator sections too warm	Temperature controls set too warm	Reset temperature controls.
	Poor door seal	Level cabinet. Adjust hinges. Replace gasket.
	Dirty condenser or obstructed grille	Check condenser and grille. Clean.
	Faulty control	Test control. Replace if failed.
	Refrigerant shortage or restriction	Check for leak or restriction. Repair, evacuate and recharge system.
Freezer section too cold	Freezer temp control set too cold	Adjust freezer temperature control.
	Faulty control	Test control. Replace if failed.
Unit runs continuously	Temperature control set too cold	Adjust temperature control.
	Dirty condenser or obstructed grille	Check condenser and grille. Clean.
	Poor door seal	Level cabinet. Adjust hinges. Replace gasket.
	Interior light remains on	Check switch. Replace if necessary.
	Faulty condenser fan or evaporator fan	Check fan and wiring. Replace if necessary.
	Faulty control	Test control. Replace if failed.
	Refrigerant shortage or restriction	Check for leak or restriction. Repair, evacuate and recharge system.
	Refrigerant overcharge	Check for overcharge. Evacuate and recharge system.
	Air in system	Check for low side leak. Repair, evacuate and recharge system.
Unit runs continuously. Temperature normal.	Ice on evaporator	See "Ice on evaporator".
Unit runs continuously. Temperature too cold.	Faulty defrost thermostat	Check thermostat. Replace if necessary.
Noisy operation	Loose flooring or floor not firm	Repair floor or brace floor.
	Cabinet not level	Level cabinet.
	Tubing in contact with cabinet, other tubing, or other metal	Adjust tubing.
	Drip pan vibrating	Adjust drain pan.
	Fan hitting another part	Ensure fan properly aligned and all attaching hardware and brackets are tight and not worn. Tighten or replace.
	Worn fan motor bearings	Check motor for loss of lubricant or worn bearings. Replace if necessary.
	Compressor mounting grommets worn or missing. Mounting hardware loose or missing	Tighten hardware. Replace grommets if necessary.
	Free or loose parts causing or allowing noise during operation	Inspect unit for parts that may have worked free or loose or missing screws. Repair as required.

Troubleshooting Chart



WARNING

To avoid risk of electrical shock, personal injury, or death, disconnect electrical power source to unit, unless test procedures require power to be connected. Discharge capacitor through a resistor before attempting to service. Ensure all earthing wires are connected before certifying unit as repaired and/or operational.

Symptom	Possible Causes	Corrective Action
Frost or ice on evaporator	Defrost thermostat faulty	Check defrost thermostat. Replace if failed.
	Evaporator fan faulty	Check fan motor. Replace if failed.
	Defrost heater remains open	Check defrost heater continuity. Replace if failed.
	Open wire or connector	Check wiring and connections. Repair as necessary.
	Refrigerant shortage or restriction	Check for leak or restriction. Repair, evacuate and recharge system.
Unit starts and stops frequently (cycles on and off)	Loose wire or thermostat connections	Check wiring and connections. Repair as necessary.
	Supply voltage out of specification	Check input voltage. Correct any supply problems.
	Overload protector open	Check overload protector for continuity. If open, replace overload. NOTE: Ensure overload/compressor are below trip temperature before testing.
	Faulty compressor motor capacitor (some compressors do not require motor capacitor)	Check capacitor for open/short. Replace if necessary. NOTE: Discharge capacitor before testing.
	Faulty fan motor	Check fan motor. Replace if failed.
	Restricted air flow	Check condenser and grille for dirt. Clean.
	Refrigerant shortage or restriction	Check for leak or restriction. Repair, evacuate and recharge system.

System Diagnosis

CONDITION	SUCTION PRESSURE VARIATION FROM NORMAL	HEAD PRESSURE VARIATION FROM NORMAL	T1 INLET TEMPERATURE VARIATION FROM NORMAL	T2 OUTLET TEMPERATURE VARIATION FROM NORMAL	T3 SUCTION TEMPERATURE VARIATION FROM NORMAL	WATTAGE VARIATION FROM NORMAL
Refrigerant Overcharge	Increase	Increase	Warmer	Warmer	Colder	Increase
Shortage of Refrigerant	Decrease	Decrease or Increase See Text	Colder	Warmer	Warmer	Decrease
Partial Restriction	Decrease	Decrease or Increase See Text Note 2	Colder	Warmer	Warmer	Decrease
Air in System	Near Normal	Increase	Warmer	Warmer	Warmer	Increase
Low Ambient Installations (High Ambients the Reverse)	Decrease	Decrease	Colder	Warmer	Warmer	Decrease
Additional Heat Load	Increase	Increase	Warmer	Warmer	Warmer	Increase
Inefficient Compressor	Increase	Normal or Decrease	Warmer or Colder	Warmer	Warmer	Decrease

Symptoms of an Overcharge

- Above normal freezer temperatures.
- Longer than normal or continuous run.
- Freezing in refrigerator.
- Higher than normal suction and head pressure.
- Higher than normal wattage.
- Evaporator inlet and outlet temperatures warmer than normal.
- Suction tube temperature below ambient. Always check for separated heat exchanger when suction temperature is colder than ambient.

Various conditions could indicate an overcharge. For example, if the cooling coil is not defrosted at regular intervals, due to a failure of the defrost system, the refrigerant will "flood out" and cause the suction line to frost or sweat. The cause of this problem should be corrected rather than to purge refrigerant from the system. Running the freezer section colder than necessary (-18.9 to -18.3 °C is considered normal package temperatures) or continuous running of the compressor for a variety of reasons, or the freezer fan motor not running, may give the indication of an overcharge.

Symptoms of Refrigeration Shortage

- Rise in food product temperature in both compartments. (See Note 1 below.)
- Long or continuous run time.
- Look for obvious traces of oil that would occur due to a leak or cracked refrigerant line.
- Lower than normal wattage.
- Compressor will be hot to touch because of the heat generated by the motor windings from long continuous running. It will not be as hot as it would be with a full charge and long run times for some other reason such as a dirty condenser.
- Depending on the amount of the shortage, the condenser will not be hot, but closer to room temperature. The capillary tube will be warmer than normal from a slight shortage.
- If the leak is on the high side of the system, both gauges will show lower than normal readings and will show progressively lower readings as this charge becomes less. The suction pressure gauge will probably indicate a vacuum.
- If the leak is on the low side of the system the suction pressure gauge will be lower than normal - probably in a vacuum - and the head pressure gauge will be higher than normal. It will probably continue to become higher because air drawn in through the leak is compressed by the compressor and accumulates in

System Diagnosis

the high side (condenser) of the system.

- Only partial frosting of evaporator instead of even frosting of entire coil.

NOTE 1: Usually the first thing that is noticed by the user is a rise in temperature foods. Although temperatures will rise in both the freezer section and the food compartment, the frozen meats and vegetables will not thaw immediately. The customer doesn't associate the problem with the freezer section and will first notice that milk and other food beverages are not cold enough.

Under some circumstances, such as in the case of forced air meatkeeper model with a slight shortage of refrigerant, freezing in the food compartment may be experienced due to the additional running time. With a refrigerant leak, however, it always gets worse and as the refrigerant charge decreases the temperature will continue to rise.

With a shortage of refrigerant the capillary line will not have a full column of liquid. As a result, there is a noticeable hissing sound in the evaporator. This should not be mistaken for the regular refrigerant boiling sounds that would be considered normal.

Symptoms of a Restriction

Always remember refrigeration (cooling) occurs on the low pressure side of a partial restriction (obviously a total restriction will completely stop the circulation of refrigerant and no cooling will take place).

Physically feel the refrigeration lines when a restriction is suspected. The most common place for a restriction is at the drier-filter or at the capillary tube inlet or outlet. If the restriction is not total there will be a temperature difference at the point of restriction, the area on the evaporator side will be cooler. In many cases frost and/or condensation will be present. A longer time is required for the system to equalize.

Any kinked line will cause a restriction so the entire system should be visually checked.

A slight restriction will give the same indications as a refrigerant shortage with lower than normal back pressure, head pressure, and wattage, warmer product temperatures.

NOTE 2: If a total restriction is on the discharge side of the compressor, higher than normal head pressures and wattages would result. This is true only while the low side is being pumped out and if the restriction was between the compressor and the first half of the condenser.

To diagnose for a restriction versus a refrigerant shortage, discharge the system, replace the drier-filter, evacuate and recharge with the specified refrigerant charge. If the unit performs normally three possibilities exist: 1) refrigerant loss, 2) partially restricted drier-filter, and 3) moisture in system.

If the unit performs as it previously did you may have a restricted capillary line or condenser or kinked line. Find the point of restriction and correct it.

A restriction reduces the flow rate of the refrigerant and consequently reduces the rate of heat removal. Complete restriction may be caused by moisture, solid contaminants in the system, or a poorly soldered joint. Moisture freezes at the evaporator inlet end of the capillary tube or solid contaminants collect in the drier-filter. The wattage drops because the compressor is not circulating the usual amount of refrigerant.

As far as pressure readings are concerned, if the restriction, such as a kinked line or a joint soldered shut is anywhere on the low side, the suction pressure would probably be in a vacuum while the head pressure will be near normal. If the restriction is on the high side, the suction pressure, again, will probably be in a vacuum while the head pressure will be higher than normal during the pump out period described earlier. In either case, it will take longer than the normal ten minutes or so for the head pressure to equalize with the low side after the compressor stops.

Symptoms of Air in System

This can result from a low side leak or improper servicing. If a leak should occur on the low side, the temperature control would not be satisfied; thus, continuous running of the compressor would result. The compressor would eventually pump the low side into a vacuum drawing air and moisture into the system. Air and R134A do not mix so the air pressure would be added to the normal head pressure, resulting in higher than normal head pressures.

One way to determine if air is in the system is to read the head pressure gauge with the product off and evaporator and condenser at the same temperature and then take the temperature on the condenser outlet tube. This temperature should be within 3° or 4° F. of what the Pressure-Temperature Relation chart shows for the given idle head pressure. If the temperature of the condenser outlet is considerably lower than the idle head pressure of the gauge this would indicate there is air in the system.

Thorough leak checking is necessary. Correct the source of the leak. Do not attempt to purge off the air because this could result in the system being undercharged. It is best to discharge, replace drier, evacuate and recharge with the specified refrigerant charge.

System Diagnosis

Symptoms of Low or High Ambient Temperature Installation

Lower ambient air temperature reduces the condensing temperature and therefore reduces the temperature of the liquid entering the evaporator. The increase in refrigeration effect due to operation in a lower ambient results in a decrease in power consumption and run time. At lower ambients there is a reduction in cabinet heat leak which is partially responsible for lower power consumption and run time.

An increase in refrigeration effect cannot be expected below a certain minimum ambient temperature. This temperature varies with the type and design of the product.

Generally speaking, ambient temperatures cannot be lower than 15.5° C. without affecting operating efficiency. Conversely, the higher the ambient temperature the higher the head pressure must be to raise the high side refrigerant temperature above that of the condensing medium. Therefore, head pressure will be higher as the ambient temperature raises.

Refrigerators installed in ambient temperatures lower than 60° F. will not perform as well because the pressures within the system are generally reduced and unbalanced. This means that the lower head pressure forces less liquid refrigerant through the capillary line. The result is the symptoms of a refrigerant shortage. The lower the ambient temperature the more pronounced this condition becomes.

When a point where the ambient temperature is below the cut-in of the Temperature Control is reached, the compressor won't run.

The drain traps will freeze in ambient temperatures of 0°C.

Heat Load

A greater heat load can result from the addition of more than normal supply of foods, such as after doing the weekly shopping. Other items contributing to an additional heat load would be excessive door openings, poor door sealing, interior light remaining on, etc.

An increase in heat being absorbed by the refrigerant in the evaporator will affect the temperature and pressure of the gas returning to the compressor. Compartment temperatures, power consumption, discharge, and suction pressures are all affected by heat load.

Pressures will be higher than normal under heavy heat load.

Disassembly Procedures



WARNING

To avoid risk of electrical shock, personal injury, or death, disconnect electrical power source to unit, unless test procedures require power to be connected. Discharge capacitor through a resistor before attempting to service. Ensure all earthing wires are connected before certifying unit as repaired and/or operational.

Door Removal

Fresh Food Door

1. Open both compartment doors. Remove door buckets, all shelving and drawers from refrigerator and freezer compartments. Place components on a padded surface to avoid damage.
2. Close both doors and tape them shut so they won't fall off unexpectedly when hinges are removed.

NOTE: To minimize possibility of personal injury and/or property damage, make sure unit doors are taped shut before you undertake the next steps:

3. On top of unit, remove screw and retain plastic cap from door hinge.
4. Remove and retain screws from top door hinge.
5. Pull tape off of door and lift door off unit. Set door on a padded surface to prevent damage to finish.
6. Remove and retain center hinge pin and all plastic shims. Note number and location of shims as you do so.

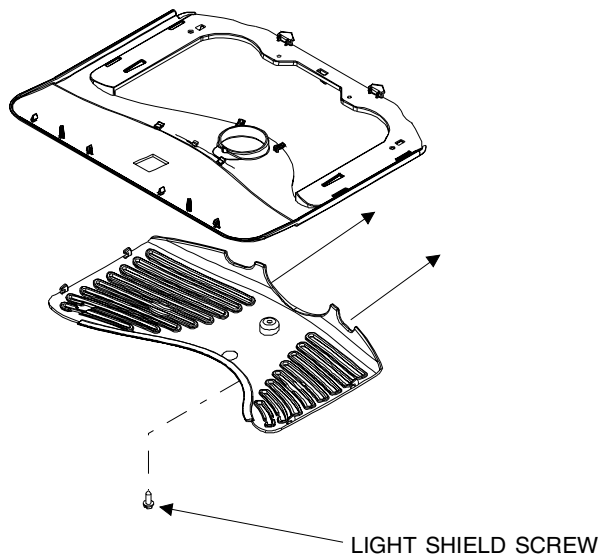

Freezer Door (some models)

1. Pull tape off freezer door and lift door off unit. Set door on a padded surface to prevent damage to finish.
2. If clearance requirements so dictate, remove center and lower door hinges:
 - a. Remove screws from center hinge bracket. Remove and retain bracket, screws, and all shims.
 - b. Remove toe grille by pulling it directly away from unit, and pop plastic cover off bottom door hinge. Grille and cover are fragile: keep both parts safe from harm.
 - c. Remove bottom hinge pin and all shims from bottom hinge bracket. Note number and location of shims. Retain all parts.
 - d. Loosen mounting screws from bottom hinge bracket. Remove and retain bracket and bolts.

Freezer Drawer (some models)

1. Open drawer to fully open position.
2. Remove upper and lower basket.
3. Remove screws one in each rail marked on side of rail.
4. Lift front of drawer up and out to remove drawer.
5. Set drawer on a padded surface to prevent damage to finish.

Refrigerator Compartment

Light Bulb

1. Loosen mounting screw from refrigerator light cover. Remove screw and slide cover to the rear to release it from holding tabs. Retain all parts.

Light Bulb Assembly

1. Loosen mounting screw from refrigerator light cover if equipped. Remove screw and slide cover to the rear to release it from holding tabs. Retain all parts.
2. Remove light bulbs.
3. Remove damper control cover and foam insert by pulling straight on sides of rear cover and tilt forward 12.7 to 25.4 millimeter. This will release the cover from the tabs holding it in place.
4. Release tension on damper control belt by squeezing tabs on bottom of belt tensioner to release tensioner from its holding tabs.
5. Slip belt off of damper control cog.
6. Use a taped putty knife to carefully pry front edge of light assembly plastic housing. This releases tabs holding up front of housing.
7. When released disconnect connector plugged in to cabinet liner.

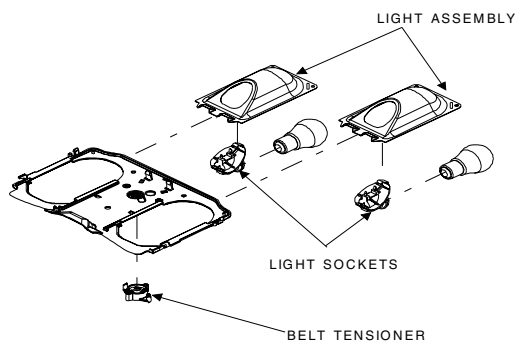

Disassembly Procedures



WARNING

To avoid risk of electrical shock, personal injury, or death, disconnect electrical power source to unit, unless test procedures require power to be connected. Discharge capacitor through a resistor before attempting to service. Ensure all earthing wires are connected before certifying unit as repaired and/or operational.

Light Bulb Sockets

1. After following procedure on removing light bulb assembly.
2. Disconnect wires to sockets.
3. Squeeze tab on back side of socket to release it from assembly.
4. Reverse procedure to reassemble.

PC Control Board

1. Remove light shield by sliding shield to rear to release cover.
2. Depress with a screw driver through two slots in the front of the light housing release tabs to release Control Board housing.
3. Control Board housing will drop down exposing Control Board.
4. Unplug two wire harnesses plugged into the Control Board.
5. Release tabs holding Control Board to housing.

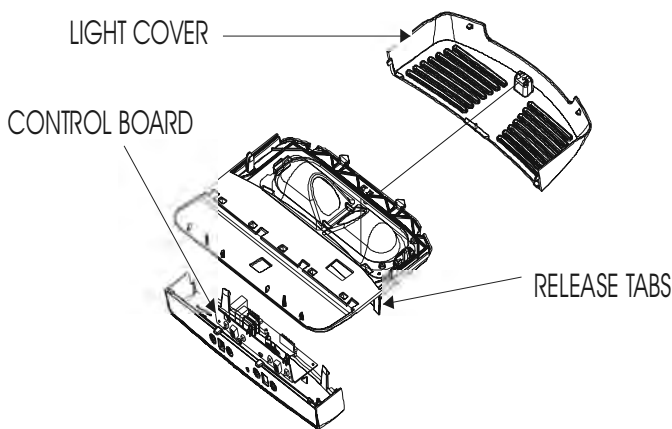

Mid Level Electronic Model

Light Switch

1. After following procedure on removing light bulb assembly.
2. Disconnect wires from light switch.
3. Squeeze tab to release light switch from light assembly.
4. Reverse procedure to reassemble.

Electronic Temp-Assure™ Damper Control

1. Remove louvered cover off of Damper Control housing by squeezing down on louvers to release from housing.
2. Remove two screws holding housing to rear wall.
3. Remove Damper Control housing.
4. Remove Foam insert by pulling it out.
5. Unplug wire harness from Damper Control.
6. Unclip Damper Control from tabs and remove.

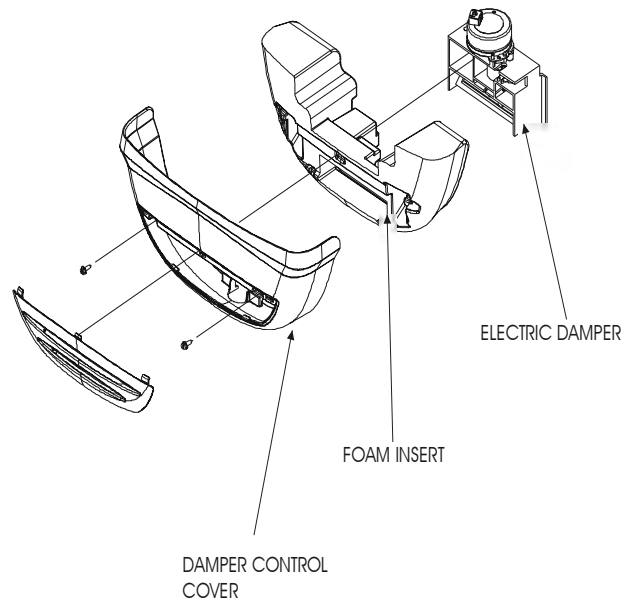

Fresh Food Thermistor (some models)

1. Remove light shield by sliding shield to rear to release cover.
2. Depress with a screw driver through two slots in the front of the light housing release tabs to release Control Board housing.
3. Control Board housing will drop down exposing Control Board and Thermistor.
4. Cut wires to Thermistor at Thermistor.
5. Remove Thermistor from clip.

Water Tank (some models)

1. Turn water off to unit.
2. Disconnect water line that supplies water tank from water valve.
3. Remove compression nut off of inlet to tank.
4. Remove crispers from fresh food compartment.

Disassembly Procedures



WARNING

To avoid risk of electrical shock, personal injury, or death, disconnect electrical power source to unit, unless test procedures require power to be connected. Discharge capacitor through a resistor before attempting to service. Ensure all earthing wires are connected before certifying unit as repaired and/or operational.

5. Disconnect compression nut from union on outlet of tank.
6. Remove two hex head screws holding tank to rear bulkhead.
7. Remove water tank and tubing.
8. Reverse procedure to reassemble.
5. Remove light bulb.
6. Squeeze tab holding light housing in place to release housing and remove.
7. Disconnect wires to socket.
8. Squeeze tab on back side of housing to release socket.

Water Dispenser (some models)

1. Turn water off to unit.
2. Remove crispers from fresh food compartment.
3. Carefully pry top cover of dispenser out and remove.
4. Remove hex head screw to release dispenser from cabinet.
5. Disconnect compression nut from union at outlet of tank.
6. Remove compression nut from tubing.
7. Pull dispenser assembly and tube out of side wall.
8. Reverse procedure to reassemble.

Freezer Compartment

Freezer Thermistor (some models)

1. Remove Thermistor cover located on the Evaporator Cover by inserting a screw driver in slot and releasing tab holding Thermistor cover on.
2. Unclip Thermistor from cover and cut wires to Thermistor.
3. Remove Thermistor.

Light Socket

1. Remove screw from rear edge of light shield.
2. Squeeze lens to release lens cover and remove.
3. With flat blade screwdriver release tabs in front of cold control knob.
4. Cold control assembly will drop down when released.

Light Switch

1. Carefully pry with taped putty knife pry the front of light bulb assembly to release tabs.
2. The whole light bulb assembly will drop down.
3. Disconnect wiring to light switch.
4. Squeeze tabs on back side of switch to release it from assembly.

Freezer Back Panel

NOTE: Freezer compartment should now be empty and walls should be clear of anything that will obstruct removal of back panel.

1. Loosen screws that mount icemaker to freezer compartment walls.
2. Pull icemaker gently away from wall of compartment. As you do so, work fill cup free of fill tube. Unplug icemaker electrical connector and remove icemaker from unit.
3. (Pull out Drawer only) Loosen and remove screws that hold 2 basket glides in place at left and right sides of compartment.
4. If unit has no icemaker pry with flatblade icemaker connection cover. Remove cover.
5. Remove hex head screws that hold back panel and remove panel.
6. Squeeze tabs on ice maker plug to release it from back panel.

Evaporator Fan, Evaporator Motor

1. Follow instructions in removing freezer back panel.
2. Remove screws that anchor evaporator fan bracket to back wall of compartment. Pull fan and bracket out of place as a unit
3. Free fan bracket from wiring harness by disconnecting wires to motor and wire in clips that go to defrost terminator.
4. Pull evaporator fan blade off motor shaft.
5. Separate bracket and motor by squeezing lower retainer bracket to release motor from bracket.
6. When reinstalling motor reference position of

Disassembly Procedures



WARNING

To avoid risk of electrical shock, personal injury, or death, disconnect electrical power source to unit, unless test procedures require power to be connected. Discharge capacitor through a resistor before attempting to service. Ensure all earthing wires are connected before certifying unit as repaired and/or operational.

terminals of new motor the same as old motor.

Defrost Terminator (Thermostat)

1. Terminator is fastened to evaporator tubing with a spring clip.
2. Snap terminator off tubing and cut wires to terminator.
3. Remove terminator from unit.

Defrost Heater

1. Follow instructions in removing freezer back panel.
2. Remove hex head screws retaining evaporator to back cabinet wall.
3. Disconnect plugs from both sides of heater.
4. Release connectors from air dams on each side of evaporator coil.
5. Grip evaporator tubing at left and right sides and tug evaporator sharply forward. Evaporator will pop out of plastic clips that hold it to back wall of unit. Then roll bottom of evaporator forward and up, exposing evaporator heater in its location amid fins at bottom of evaporator.
6. Taking care to notice how and where they are placed, remove spring clips that hold heater into evaporator fins.
7. Pull evaporator heater out of evaporator fins, being careful that heater electrical leads do not snag on air dams, evaporator fins, tubing or other object.

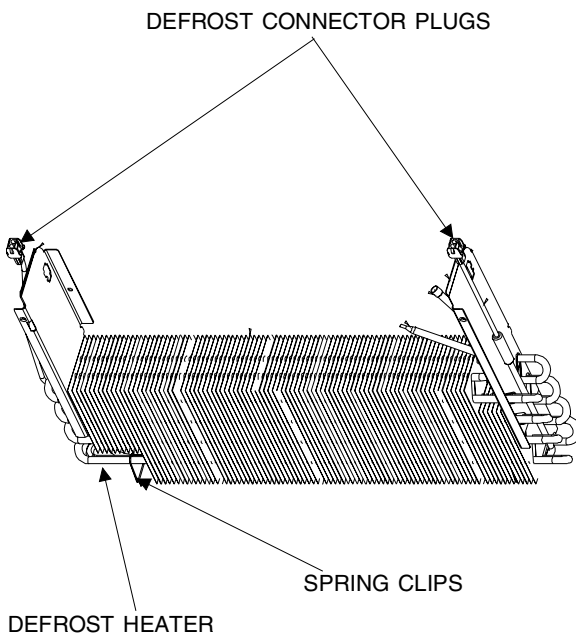

Evaporator Removal

NOTE: Reclaim refrigerant per instructions in "Service Procedures" before attempting evaporator removal. To avoid system contamination, do not leave system open for more than 10 minutes.

1. Follow instructions in removing freezer back panel.
2. Remove defrost thermostat. Refer to defrost thermostat removal.
3. Remove defrost heater. Refer to defrost heater removal.
4. Install protective cloth to prevent damage to cabinet liner
5. Unbraid suction copper fitting at evaporator.
6. Score and break copper capillary at evaporator.
7. Install new evaporator and reassemble taking care in not kinking tubing when reassembling.

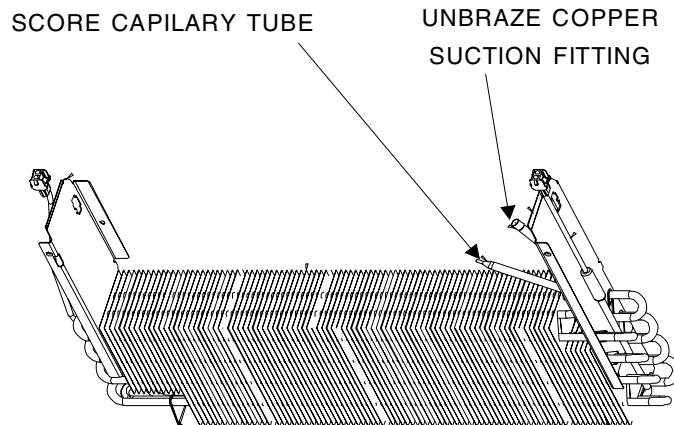

Disassembly Procedures



WARNING

To avoid risk of electrical shock, personal injury, or death, disconnect electrical power source to unit, unless test procedures require power to be connected. Discharge capacitor through a resistor before attempting to service. Ensure all earthing wires are connected before certifying unit as repaired and/or operational.

Drawer Assembly (some models)

1. Open drawer to fully open position.
2. Remove upper basket.
3. Remove screws one in each rail marked on side of rail.
4. Lift front of drawer up and out to remove drawer.

Drawer Rails

1. Remove screws inside plastic rail retainer.
2. Remove rails from retainer by depressing plastic tabs on back side of retainer.
3. Slide rails off of retainer.

Rack and Pinion Gear

1. Remove drawer assembly (see Drawer Assembly Removal).
2. Extend drawer rails to full open position, remove rails from retainer by depressing plastic tabs on back side of retainer.
3. Slide rails, rack and pinion gear off of retainer.
4. Reverse procedure to reassemble.

Note: When reinstalling rails, rack and pinion gear after latching rails in place, slide rails, rack and pinion to the fully closed position and then pull out to synchronize the rack and pinion gears.

Bottom of Cabinet

Front Roller Assembly

1. Remove toe grille by pulling it straight away from unit.
2. Raise front of refrigerator at least 101.6mm off the deck and block it up.
3. Unscrew leveling bolt until wheel is free of leveling bolt.
4. Tip wheel assembly down until wheel assembly will slide out of mount from the rear of assembly.
5. Remove roller assembly from unit.

Rear Roller Assembly

NOTE: Condensate drip pan may spill when steps 1 thru 4 are performed. Have a towel ready to mop up spillage.

1. Tape both doors shut to prevent doors from opening
2. Raise back of refrigerator at least 101.6mm off the deck and block it up.
3. Remove machine-compartment cover.
4. Locate and slide roller pins out of rollers.
5. Install new rollers and reinstall pins.

Machine Compartment

Condenser Fan & Fan Motor

1. Remove machine compartment cover.
2. Unplug wiring harness connector from fan motor.
3. On backside of fan motor, screws secure the motor to its brackets. Remove those screws.
4. Note which side of fan blade is "front" and which side is "rear." Then use pliers to loosen nut that secures fan blade to motor shaft. Remove nut and fan blade.

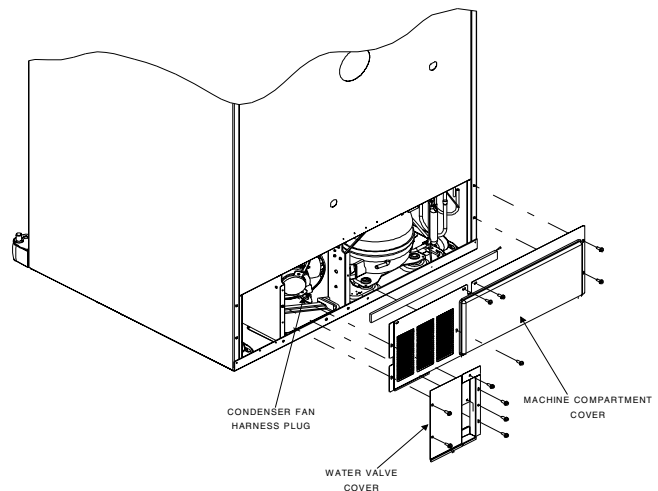

Compressor

NOTE: Install new drier and compressor per instructions in "Service Procedures." Evacuate and recharge sealed system per instructions in "Service Procedures."

1. Remove machine compartment cover.
2. Remove drier.
3. Disconnect all compressor wiring and overload/relay assembly.
4. Unbraid low and high pressure lines at compressor.
5. Remove compressor mounting bolts.
6. Lift compressor out of unit.

Disassembly Procedures



WARNING

To avoid risk of electrical shock, personal injury, or death, disconnect electrical power source to unit, unless test procedures require power to be connected. Discharge capacitor through a resistor before attempting to service. Ensure all earthing wires are connected before certifying unit as repaired and/or operational.

Overload/Relay/Capacitor

1. Remove machine compartment cover.
2. Using fingers and standard screwdriver, press and pry bale strap off the overload/relay assembly
3. Disconnect wires from overload/relay assembly. Reference wire location.
4. Unplug overload/relay assembly from compressor.

Condensate Drain Pan

NOTE: Condensate drip pan may spill when steps 1 thru 4 are performed. Have a towel ready to mop up spillage.

1. Remove machine compartment cover.
2. Tape both doors shut to prevent doors from opening
3. Raise back of refrigerator at least 101.6mm off the deck and block it up.
4. Remove Rear torx head screws holding base pan and loosen front torx head screws on bottom of cabinet.
5. Carefully lower basepan taking care not to kink tubing to compressor or condenser.
6. Remove hex screws holding condenser fan shroud to basepan.
7. Lift shroud up and out of the way to allow removal of condensate drain pan.
8. Remove drain pan.

Condensate Drain Tube

1. Remove machine compartment cover.
2. Drip tube is mounted to bottom of cabinet with clip. Reach into machine compartment and squeeze the clip to release drain tube.
3. Pull drip tube down, off drain nipple and back, out of unit.

Condenser Removal

NOTE: Install new drier per instructions in "Service Procedures." Evacuate and recharge sealed system per instructions in "Service Procedures."

1. Remove machine compartment covers.
2. Unbraid tubing going to PC loop and heat exchanger.
3. Disconnect all machine compartment wiring at molex plug to cabinet.
4. Tape both doors shut to prevent doors from opening
5. Raise back of refrigerator at least 152.4mm off the deck and block it up.
6. Remove torx head screws to drop base pan and

condenser out of unit.

7. Remove basepan and condenser out of unit.
8. Unbraid discharge and condenser out at condenser.
9. Unsnap condenser from basepan and replace.

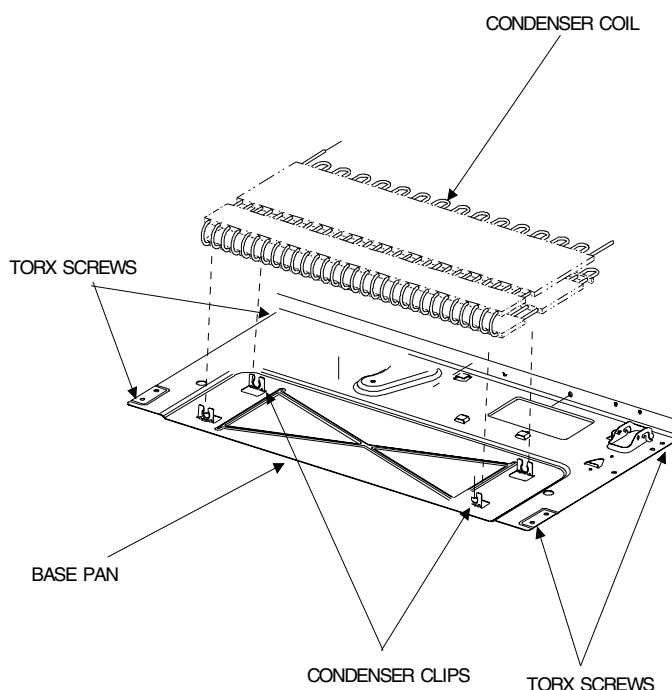

Control Board (Mid Level)



WARNING

To avoid risk of electrical shock that can cause death or severe personal injury, disconnect unit from power before servicing unless tests require power. Discharge capacitors through a 10,000-ohm resistor before handling. Wires removed during disassembly must be replaced on correct terminals to ensure proper earthing and polarization.

Programming Mode:

Note: The Program Code is located on the Serial Plate on this unit after the word Code.

1. Open the Fresh Food door and hold the Fresh Food door light switch closed while pushing the Freezer Temperature Down  Key pad 3 times consecutively.

Note: The 3 Keystrokes must be done consecutively and within 10 seconds.

2. Release the Fresh Food door light switch.
3. The control will display PE to confirm entry into the programming mode.

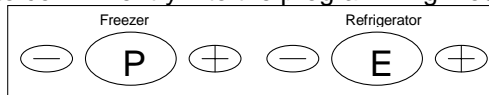



4. Entry is confirmed by pressing the Freezer Down  key once more.

Note: All control functions will be turned off (Compressor, Defrost, Evaporator Fan, the damper will remain in its current position)

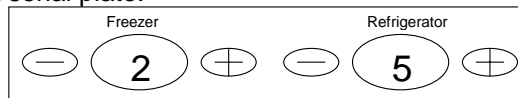
5. The control will display the current Program Code. This value should be validated with the Program Code printed on the unit serial plate.



Note: If the Program Code is correct, the Programming Mode is exited by closing the Refrigerator door(s).

6. To set the desired Program Code number press the Freezer and Refrigerator UP  keys. The corresponding digit will be advanced with each key press.
 7. Once the desired Program Code is displayed, press the Freezer DOWN  Key until the Program Code begins flashing indicating it has been saved.
- Note:** If you attempt to enter an invalid Program Code the control will not save the new code, but will flash the old code and this will be displayed. (The unit will NOT run with a Program Code of 00).
8. Once the Program Code has been saved the Programming Mode is exited by closing the Refrigerator door(s). If the new code is incorrect this process should be repeated after closing the Refrigerator door(s).

The Programming mode can be exited at any time by closing the Refrigerator Door(s).

Defrost Operation:

The Control Board adapts the compressor run time between defrosts to achieve optimum defrost intervals by monitoring the length of time the defrost heater is on.

After initial power up, defrost interval is 4 hours compressor run time. Defrost occurs immediately after the 4 hours.

Note: Once unit is ready to defrost there is a 4 minute wait time prior to the beginning of the defrost cycle. Optimum defrost is 15 minutes. Each additional minute the defrost thermostat remains closed, 1 hr. is subtracted from the previous defrost interval. Each minute the thermostat opens prior to optimum defrost, it extends the next defrost interval 1 hr. When defrost thermostat opens there is a 4-6 minute drip time before compressor restarts or Control Board will terminate defrost at 25 minutes if defrost thermostat has not opened and will reset the defrost interval to the 8 hr. minimum setting. 4 hours of continuous compressor run resets the next defrost interval to 8 hours and will initiate a defrost, if 8 hours of compressor run time has also occurred.

Forced Defrost Mode:

The forced defrost function is performed using the refrigerator display and keypad. Enter the Forced Defrost Mode by performing the following sequence of events:

1. Hold the refrigerator door light switch closed.
2. Press the Refrigerator Temperature Down  keypad 3 times consecutively.

Note: The 3 keystrokes must be consecutive and within 10 seconds.

Control Board (Mid Level)



WARNING

To avoid risk of electrical shock that can cause death or severe personal injury, disconnect unit from power before servicing unless tests require power. Discharge capacitors through a 10,000-ohm resistor before handling. Wires removed during disassembly must be replaced on correct terminals to ensure proper earthing and polarization.

3. Release the refrigerator door light switch.
4. The control will display Fd to confirm entry into the Forced Defrost Mode.

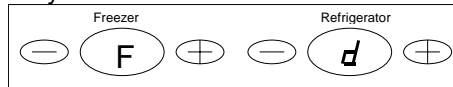

5. Entry is confirmed by pressing the Refrigerator Down  key once more. The unit is off and in the Defrost Mode.

Note: All control functions will be turned off (Compressor, Defrost, Evaporator Fan, the damper will remain in its current position).

6. The control will default to the short run period test as shown here:

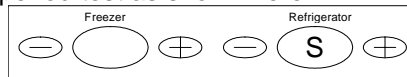

Note: You can toggle between the (S)hort and (L)ong test mode by pressing the Refrigerator UP  Key. Long Test mode is used for factory test and should not be used in the field.

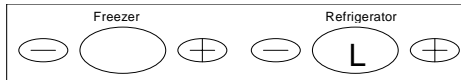

7. Once the desired mode is displayed, confirm the forced defrost by pressing the Refrigerator Down  Key once. The defrost will begin immediately and the display will return to a normal operating display with set point values.

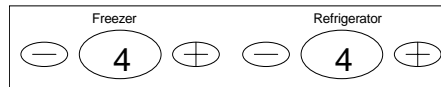

8. Close the Refrigerator door(s). You are in the defrost mode

Note: Forced Defrost mode can be exited at any time prior to step 7 by closing the Refrigerator Door(s).

Service Test Mode:

The service test functions are performed using the refrigerator display and keypad. Enter the Service Test Mode by performing the following sequence of events:

1. Hold the refrigerator door light switch closed.
2. Press the Refrigerator Temperature Up  keypad 3 times consecutively.

Note: The 3 Keystrokes must be done consecutively and within 10 seconds.

3. Release the refrigerator door light switch.
4. The control will display SE to confirm entry into the service mode.

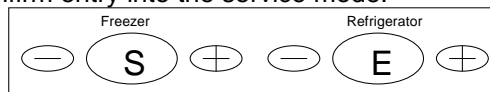

5. Entry to the Service Menu is confirmed by pressing the Refrigerator Up  key once more.
6. The control will display its software version for 3 seconds.

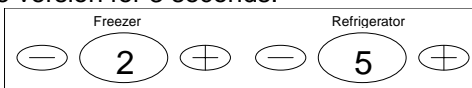

7. Following the software revision display the freezer display will read the first test number in the diagnostic tree. The refrigerator display will be blank

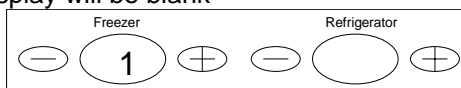

Note: All control functions will be turned off (Compressor, Defrost, Evaporator Fan, the damper will remain in its current position).

8. You are now in the SERVICES TEST operational mode and may use the diagnostic tests.

The Service Test Mode can be exited at any time by closing the Refrigerator Door(s).

Control Board (Mid Level)



WARNING

To avoid risk of electrical shock that can cause death or severe personal injury, disconnect unit from power before servicing unless tests require power. Discharge capacitors through a 10,000-ohm resistor before handling. Wires removed during disassembly must be replaced on correct terminals to ensure proper earthing and polarization.

Service Test 1 – Defrost Thermostat & Defrost Circuit Test

When selected this test will display the state of the defrost thermostat. In order to perform this test the defrost heater will be energized. The test is activated and deactivated using the Refrigerator Up \oplus key. Once activated, this test must be de-activated to move to another test number. The Freezer Up \oplus / Down \ominus keys allow selection of the test to be performed.

This test also allows observation and measurement of proper defrost function. You can observe defrost heat and voltages while the test is activated.

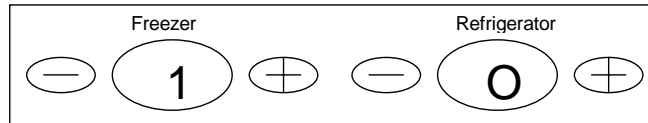

DEFROST THERMOSTAT OPEN

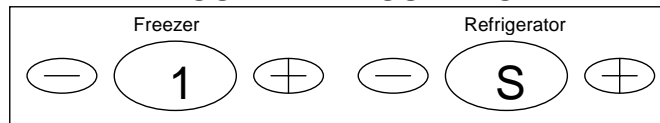

DEFROST THERMOSTAT SHORTED (CLOSED)

Service Test 2 – Compressor/Condenser Fan Test

When selected and activated this test will operate the Compressor/Condenser Fan circuit. You should evaluate proper operation of the compressor and condenser fan. The Refrigerator Up \oplus key will toggle between “O” / “F” (ON & OFF) the compressor drive circuit. The test must be “deactivated” or in the OFF position to move to another test selection.

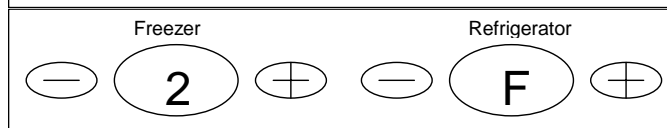
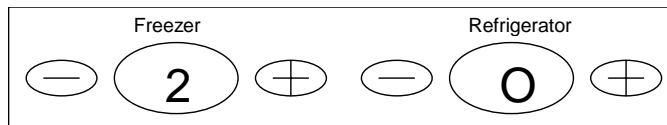

OBSERVE COMPRESSOR & CONDENSER FAN FUNCTION

Service Test 3 – Evaporator/Freezer Fan Test

When selected and activated this test will operate the freezer fan. The Refrigerator Up \oplus key will toggle between “O” / “F” (ON & OFF) the fan drive circuit. You will have to inspect the fan for proper function. The test must be “deactivated” or in the OFF position to move to another test selection.

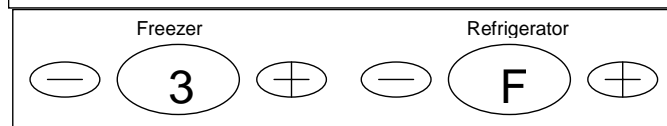
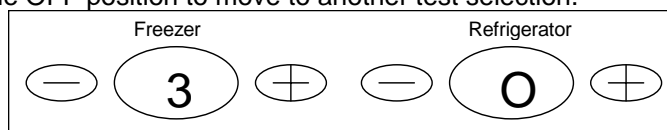

OBSERVE FAN OPERATION

Control Board (Mid Level)



WARNING

To avoid risk of electrical shock that can cause death or severe personal injury, disconnect unit from power before servicing unless tests require power. Discharge capacitors through a 10,000-ohm resistor before handling. Wires removed during disassembly must be replaced on correct terminals to ensure proper earthing and polarization.

Service Test 4 – Fresh Food Thermistor Test

When selected and activated this test will display Pass, Open, Short result for a test on the Fresh Food Thermistor circuit as show below. The test is activated and de-activated via the Refrigerator Up  key, and must be de-activated to move to another test selection.

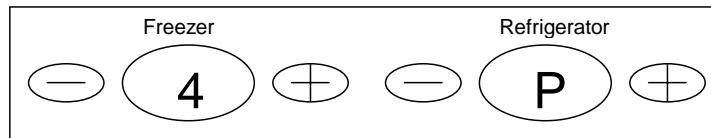

PASS RESULT

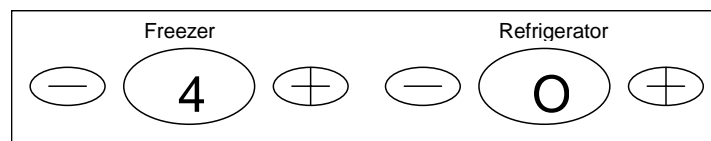

OPEN RESULT

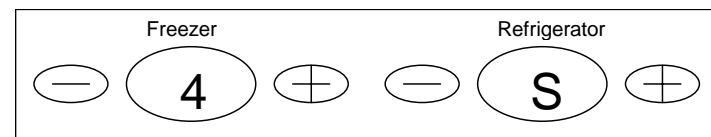

SHORT RESULT

Service Test 5 – Freezer Thermistor Test

When selected this test will display Pass, Open, Short result for a test on the Freezer Thermistor circuit as show below. The test is activated and de-activated via the Refrigerator Up  key, and must be de-activated to move to another test selection.

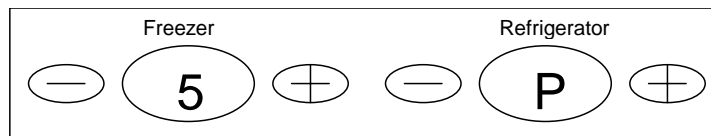

PASS RESULT

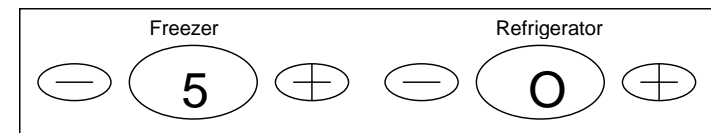

OPEN RESULT

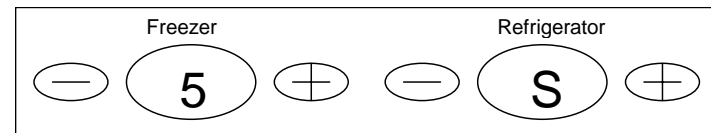

SHORT RESULT

Control Board (Mid Level)



WARNING

To avoid risk of electrical shock that can cause death or severe personal injury, disconnect unit from power before servicing unless tests require power. Discharge capacitors through a 10,000-ohm resistor before handling. Wires removed during disassembly must be replaced on correct terminals to ensure proper earthing and polarization.

Service Test 6 – Open Damper Test

When selected this test will indicate the current position “O” / “C” (OPEN / CLOSED) of the refrigerator damper. The Refrigerator Up key will toggle the damper open and closed. You must allow 1 minute for each attempt to change the damper position. You should observe proper damper function.

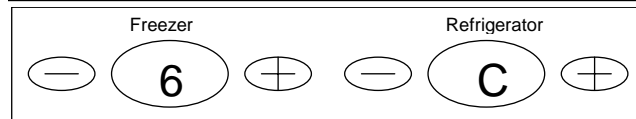
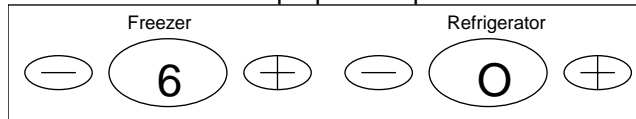

OBSERVE DAMPER FUNCTION



CAUTION

Adjustments of Service Test 7 or Service Test 8 will alter the performance of the unit.

Service Test 7 – FF Performance Adjustment

This test will allow adjustment of the control performance points. Each step will incrementally change the Refrigerator performance warmer (towards 1) or colder towards (9) as adjusted. The default value is 5.

The refrigerator / Up/Down keys are used to adjust the Performance Offset value.
WARMER ←(1 2 3 4 (5) 6 7 8 9) → COLDER.

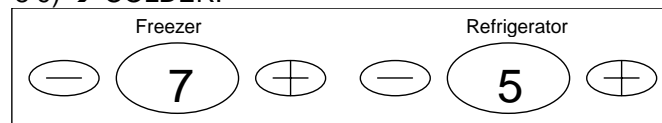

DEFAULT

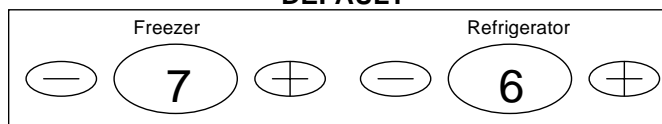

COLDER

The last FF Performance Offset value displayed before leaving test 7 will be saved when the refrigerator door(s) is closed.

Service Test 8 – FZ Performance Adjustment

This test will allow the adjustment of the control performance points. Each step will incrementally change the Freezer performance warmer (towards 1) or colder towards (9) as adjusted. The default value is 5.

The refrigerator / Up/Down keys are used to adjust the Performance Offset value.
WARMER ←(1 2 3 4 (5) 6 7 8 9) → COLDER

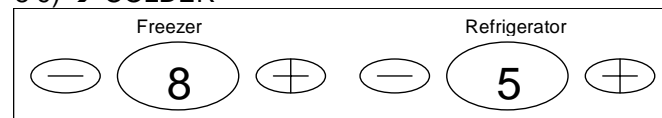

DEFAULT

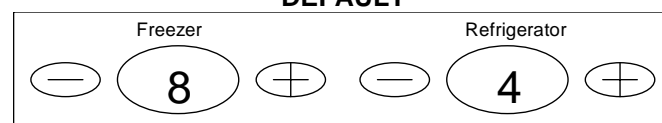

WARMER

The last FZ Performance Offset value displayed before leaving test 8 will be saved when the refrigerator door(s) is closed.