

# Service

This manual is to be used by qualified appliance technicians only. Maytag does not assume any responsibility for property damage or personal injury for improper service procedures done by an unqualified person.

## 27" Dryer

This Base Manual covers general information  
Refer to individual Technical Sheet  
for information on specific models

This manual includes, but is  
not limited to the following:

**MDE9700A\***  
**MDG9700A\***

# Important Information

## Important Notices for Servicers and Consumers

Maytag will not be responsible for personal injury or property damage from improper service procedures. Pride and workmanship go into every product to provide our customers with quality products. It is possible, however, that during its lifetime a product may require service. Products should be serviced only by a qualified service technician who is familiar with the safety procedures required in the repair and who is equipped with the proper tools, parts, testing instruments and the appropriate service information. **IT IS THE TECHNICIANS RESPONSIBILITY TO REVIEW ALL APPROPRIATE SERVICE INFORMATION BEFORE BEGINNING REPAIRS.**



### **WARNING**

To avoid risk of severe personal injury or death, disconnect power before working/servicing on appliance to avoid electrical shock.

To locate an authorized servicer, please consult your telephone book or the dealer from whom you purchased this product. For further assistance, please contact:

### Customer Service Support Center

CAIR Center

Web Site

Telephone Number

WWW.MAYTAG.COM ..... 1-800-688-9900

CAIR Center in Canada ..... 1-800-688-2002

### Recognize Safety Symbols, Words, and Labels



### **DANGER**

**DANGER**—Immediate hazards which **WILL** result in severe personal injury or death.



### **WARNING**

**WARNING**—Hazards or unsafe practices which **COULD** result in severe personal injury or death.



### **CAUTION**

**CAUTION**—Hazards or unsafe practices which **COULD** result in minor personal injury, product or property damage.

Important Information .....	2
Important Safety Information .....	4
General Information	
Model Identification .....	8
Serial Label Location .....	8
Model Nomenclature .....	9
Troubleshooting	
Troubleshooting General Symptoms .....	10
Component Testing Information	
Component Testing Information .....	14
Disassembly Procedures	
Door Reversal/Disassembly .....	16
Interior Light .....	17
Top Removal .....	17
Drum Baffle Removal .....	18
Console Removal .....	18
Front Panel Removal .....	19
Heater Assembly Removal .....	19
Front Bulkhead Removal .....	21
Moisture Sensor Removal .....	22
Belt Removal .....	22
Belt Switch Removal .....	23
Drum Removal .....	23
Motor/Blower Assembly Removal .....	32
Rear Bulkhead Removal .....	26
Rear Roller Removal .....	27
Gas Model Disassembly Procedures	
Igniter Removal .....	27
Burner Removal .....	28
Appendix A	
Installation Instructions .....	29
Appendix B	
Use And Care .....	42

# Important Safety Information



## WARNING

To avoid risk of fire, electric shock, serious injury, or death when using your dryer, follow these basic precautions:

1. Read all instructions before using dryer.
2. Install dryer according to Installation Instructions. Refer to the Grounding Instructions in the Installation Instructions for proper grounding of the dryer.
3. Do not dry articles that have been cleaned in, washed in, soaked in, or spotted with gasoline, dry-cleaning solvents, or other flammable or explosive substances. Vapors could ignite or explode.
4. Do not use dryer to dry clothes which have traces of any flammable substance, such as vegetable oil, cooking oil, machine oil, flammable chemicals, thinner, etc., or anything containing wax or chemicals, such as mops and cleaning cloths. Flammable substances may cause fabric to catch fire by itself.
5. Do not store or use gasoline or other flammable vapors and liquids near this or any other appliance.
6. Do not allow children to play on or in dryer. Close supervision of children is necessary when dryer is used near children, a safety rule for all appliances.
7. Before dryer is removed from service or discarded, remove doors to drying compartment.
8. Do not reach into dryer if cylinder is revolving.
9. Do not install or store dryer where it will be exposed to water and/or weather.
10. Do not tamper with dryer controls.
11. Do not repair or replace any part of dryer or attempt any service, unless specifically recommended in user-maintenance instructions or in published user-repair instructions that you understand and have skills to carry out, if you are a consumer.
12. To reduce risk of electric shock or fire, do not use extension cords or adapters to connect dryer to electrical power source.
13. Use the dryer only for its intended purpose, drying clothes.
14. Always disconnect dryer from electrical supply before attempting any service. Disconnect power cord by grasping the plug, not the cord.
15. Do not use heat to dry articles containing foam rubber or similarly textured rubberlike materials.
16. Always clean the lint filter after every load. A layer of lint in the filter reduces drying efficiency and prolongs drying time.
17. Use only fabric softeners or products to eliminate static that are appropriate for automatic dryers.
18. Keep your dryer in good condition. Bumping or dropping dryer can damage safety features. If damage occurs, have dryer checked by qualified service technician.
19. Replace worn power cords and/or loose plugs.
20. Do not tumble fiberglass curtains and draperies unless the label says it can be done. If they are dried, wipe out the cylinder with a damp cloth to remove particles of fiberglass.
21. Always read and follow manufacturer's instructions on packages of laundry aids. Heed all warnings or precautions. To reduce risk of poisoning or chemical burns, keep products away from children at all times, preferably, in a locked cabinet.
22. Never operate dryer with guards and/or panels removed.
23. Do not operate dryer with missing or broken parts.
24. Do not bypass safety devices.
25. Keep area around the exhaust opening and adjacent surrounding areas free from accumulation of lint, dust, and dirt.
26. Interior of dryer and exhaust duct should be cleaned periodically by qualified service personnel.
27. Dryer will not operate with loading door open. DO NOT bypass door safety switch by permitting dryer to operate with door open. Dryer will stop tumbling when door is opened. Do not use dryer if it does not stop tumbling when door is opened or starts tumbling without pressing or turning the START mechanism. Remove the dryer from use and call the service person.
28. Remove laundry immediately after the dryer stops.
29. ALWAYS follow the fabric care instructions supplied by the garment manufacturer.

## Save These Instructions

# Important Safety Information

## Electrical Service Information

### Electrical Dryers

- 240 VAC, 60 Hz, 30 Amps, 3–wire or 4–wire installations

### Gas Dryers

- 120 VAC, 60 Hz, 15 Amps, 3–wire installations

## About Ground Wires

In the event of an electrical short circuit, a ground wire reduces the risk of electric shock by providing an escape wire for the electric current.

Standard accepted color coding for ground wires is **green** or **green with a yellow stripe**.

Grounding wires and wires colored like grounding wires are **NOT** to be used as current carrying conductors.



## WARNING

To reduce the risk of fire, electric shock, serious injury or death, all wiring and grounding must conform with the latest edition of the National Electric Code, or the Canadian Electrical Code, and such local regulations as might apply. It is the customer's responsibility to have the wiring and fuses checked by a qualified electrician to make sure your home has adequate electrical power to operate the dryer.



## WARNING

**To avoid risk of personal injury or death due to electrical shock:**

- **Observe all local codes and ordinances.**
- Disconnect electrical power to unit before servicing.
- Ground appliance properly.
- Check with a qualified electrician if you are not sure this appliance is properly grounded.
- DO NOT ground to gas line.
- DO NOT ground to cold water pipe if pipe is interrupted by plastic, nonmetallic gaskets, or other insulating (nonconducting) materials.
- DO NOT modify plug on power cord. If plug does not fit electrical outlet, have proper outlet installed by qualified electrician.
- DO NOT have a fuse in the neutral or ground circuit. A fuse in the neutral or ground circuit could result in an electrical shock.
- DO NOT use an extension cord with this appliance.
- DO NOT use an adapter plug with this appliance.
- DO NOT pinch power cord.



## WARNING

To reduce the risk of fire and exposure to combustion gases, the dryer **MUST** be exhausted to the outdoors. **DO NOT** exhaust dryer air into a window well, gas vent, chimney or enclosed, unventilated area, such as an attic, wall, ceiling, crawl space under a building or concealed space of a building.

## Gas Dryer Power Supply

This equipment **MUST** be grounded. In the event of an electrical short circuit, grounding reduces the risk of electric shock by providing an escape wire for the electrical current. This unit is equipped with a cord having a grounding wire with a grounding plug. The plug must be plugged into an outlet that is properly installed and grounded.

Consult a qualified electrician or servicer if grounding instructions are not completely understood, or if doubt exists as to whether the equipment is properly grounded.

Do not use an extension cord. If the product power cord is too short, have a qualified electrician install a three–slot receptacle. This unit should be plugged into a separate 60 hertz circuit with the electrical rating as shown on the serial plate.

## Proper Grounding and Polarization for 120 Volts Wall Outlets

For the safety of our customers and the service technician ALL Amana gas dryers have a three–prong power cord and **MUST** be connected to a properly polarized and grounded wall outlet. This information was written for those who do not understand grounding and polarization of a wall outlet. A 120 VAC wall outlet must always be wired as shown below.

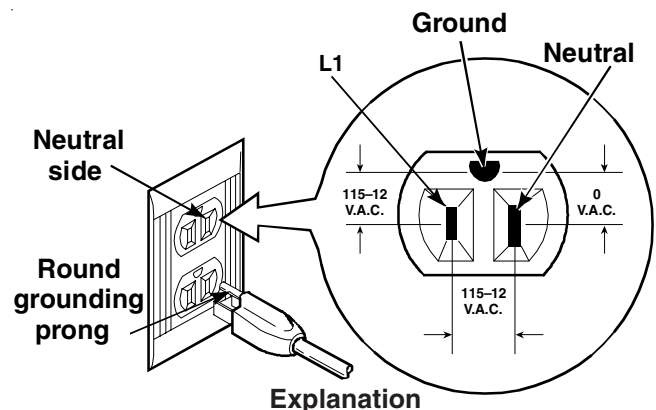

**Polarization**—This means that the larger slot must be neutral and the small slot must be hot (live).

**Mispolarized**—The outlet is miswired so that the larger slot is hot (live) and the smaller slot is neutral.

**Grounded**—This means the round hole connection is connected to ground through a connection to the main power panel.

**Ungrounded**—The round hole connection is not connected to a ground and/or the main power panel.

# Important Safety Information

## Gas Connection Information

### **WARNING**

To avoid death, personal injury or property damage, from fire or explosion, information in this manual must be followed exactly.

Do not store or use gasoline or other flammable vapors and liquids in the vicinity of this or any other appliance.

#### **WHAT TO DO IF YOU SMELL GAS**

- Do not try to light any appliance.
- Do not touch any electrical switch; do not use any phone in your building.
- Immediately call your gas supplier from a neighbor's phone. Follow the gas supplier's instructions.
- If you cannot reach your gas supplier, call the fire department.

Installation and service must be performed by a qualified installer, service agency or the gas supplier.

### **WARNING**

To reduce the risk of fire and exposure to combustion gases, the dryer **MUST** be exhausted to the outdoors. **DO NOT** exhaust dryer air into a window well, gas vent, chimney or enclosed, unventilated area, such as an attic, wall, ceiling, crawl space under a building or concealed space of a building.



### **WARNING**



#### **Warning-**

**Plastic or nonmetal flexible duct presents a potential fire hazard.**

#### **Exhaust Ductwork Guidelines:**

- 1. NEVER USE PLASTIC OR NONMETAL FLEXIBLE DUCT.**  
This can kink, reduce air flow causing service problems, and presents a potential fire hazard.
- 2. Use 4" diameter rigid metal exhaust duct.**  
Do not use smaller duct. Minimize the length of duct and the number of elbows. Secure joints with duct tape. Do not use screws.
- 3. Clean out previously used exhaust duct.**  
Replace kinked or crushed sections. Be sure the exhaust hood flap opens and closes freely.
- 4. If flexible duct must be used, use only the type with a stiff sheet metal wall. Do not kink or crush the duct. Do not use flexible duct with a thin foil wall.**
- 5. Refer to the installation instruction for additional dryer exhaust information.**

DC68-02013A

# Important Safety Information



**⚠ WARNING/AVERTISSEMENT**

TO REDUCE THE RISK OF ELECTRIC SHOCK, DISCONNECT THIS APPLIANCE FROM THE POWER SUPPLY BEFORE ATTEMPTING ANY USER MAINTENANCE. TURNING THE CONTROLS TO THE OFF POSITION DOES NOT DISCONNECT THIS APPLIANCE FROM THE POWER SUPPLY.

POUR RÉDUIRE LE RISQUE DE DÉCHARGE ÉLECTRIQUE, DÉBRANCHEZ CET APPAREIL AVANT DE FAIRE TOUT ENTRETIEN. LA MISE À L'ARRÊT DES COMMANDES NE COUPE PAS L'ALIMENTATION DE CET APPAREIL.

DC68-02056A-01

**⚠ WARNING**

**SEE INSTALLATION INSTRUCTIONS**

**MINIMUM CLEARANCES FOR CLOSET AND ALCOVE INSTALLATIONS**

SIDES 0 IN., REAR 0 IN.  
TOP 17 IN., CLOSET FRONT 2 IN.

CLOSET FRONT MUST HAVE TWO UNOBSTRUCTED AIR OPENINGS COMBINED TOTAL AREA 72 SQ. IN. MIN. LOCATED 3 IN. MIN. FROM TOP AND BOTTOM. LOUVERED DOOR WITH EQUIVALENT AIR OPENING IS ACCEPTABLE..

THIS APPLIANCE MUST BE GROUNDED ACCORDING TO THE REQUIREMENTS OF NATIONAL AND LOCAL CODES IN ORDER TO AVOID THE POSSIBILITY OF HAZARD DUE TO ELECTRICAL SHOCK.

**⚠ CAUTION / AVERTISSEMENT**

A CLOTHES DRYER PRODUCES COMBUSTIBLE LINTS. EXHAUST OUTDOORS. SEE INSTALLATION INSTRUCTION BOOK.

UN SÈCHE-LINGE PRODUIT DES PELUCHES COMBUSTIBLES. RELIEZ LE SÈCHE LINGE À UNE ÉVACUATION D'AIR. REPORTEZ-VOUS AU MANUEL D'INSTRUCTIONS.

DC68-02057A



**⚠ WARNING:** TO AVOID FIRE HAZARD, INCLUDING SPON TANEIOUS COMBUSTION, DO NOT DRY ARTICLES CONTAINING FOAM OR SIMILARY TEXTURED RUBBERLIKE MATERIALS OR A MATERIAL ON WHICH YOU HAVE USED A CLEANING SOLVENT OR WHICH CONTAINS FLAMMABLE LIQUIDS OR SOLIDS (SUCH AS GASOLINE, KEROSENE, TABLE OR COOKING OILS, WAXES, ETC.)

**⚠ CAUTION:** DRY ONLY FABRICS CLEANED IN WATER. A CLOTHES DRYER PRODUCES COMBUSTIBLE LINT AND SHOULD BE EXHAUSTED OUTDOORS. CARE SHOULD BE TAKEN TO PREVENT THE ACCUMULATION OF LINT AROUND THE EXHAUST OPENING AND IN THE SURROUNDING AREA. SEE INSTALLATION INSTRUCTION BOOK WHEN DISCARDING OR STORING YOUR OLD CLOTHES DRYER. **REMOVE THE DOOR**

GAS DRYERS EQUIPPED WITH AN INTERMITTENT TYPE IGNITION DEVICE.

DC68-02018E

**⚠ WARNING/AVE**

THIS CONTROL BOARD IS INTENTIONALLY NOT GROUNDED AND MAY PRESENT A RISK OF ELECTRIC SHOCK ONLY DURING SERVICING. SERVICE PERSONNEL — DO NOT CONTACT THIS PART WHILE APPLIANCE IS ENERGIZED.

# General Information

## Model Identification

Complete registration card and promptly return. If registration card is missing:

- For Maytag product call 1-800-688-9900 or visit the Web Site at [www.maytag.com](http://www.maytag.com)
- For product in Canada call 1-866-587-2002 or visit the Web Sites at [www.maytag.com](http://www.maytag.com) or [www.jennair.com](http://www.jennair.com)

When contacting provide product information located on rating plate. Record the following:

Model Number: \_\_\_\_\_  
Manufacturing Number: \_\_\_\_\_  
Serial or S/N Number: \_\_\_\_\_  
Date of purchase: \_\_\_\_\_  
Dealer's name and address: \_\_\_\_\_



Serial Label is located in the lower center of the door opening and back panel.

## Service

Keep a copy of sales receipt for future reference or in case warranty service is required. To locate an authorized servicer:

- For Maytag product call 1-800-462-9824 or visit the Web Site at [www.maytag.com](http://www.maytag.com)
- For product in Canada call 1-866-587-2002 or visit the Web Site at [www.maytag.com](http://www.maytag.com)

Warranty service must be performed by an authorized servicer. We also recommend contacting an authorized servicer, if service is required after warranty expires.

## Parts and Accessories

Purchase replacement parts and accessories over the phone. To order accessories for your product call:

- For Maytag product call 1-800-462-9824 or visit the Web Site at [www.maytag.com](http://www.maytag.com)
- For product in Canada call 1-866-587-2002 or visit the Web Sites at [www.maytag.com](http://www.maytag.com) or [www.jennair.com](http://www.jennair.com)

## Extended Service Plan

We offer long-term service protection for this new oven.

- Dependability Plus<sup>SM</sup> Extended Service Plan is specially designed to supplement Maytag's strong warranty. This plan covers parts, labor, and travel charges.

Call 1-800-925-2020 for information.





# General Information

## 27" Dryer Nomenclature

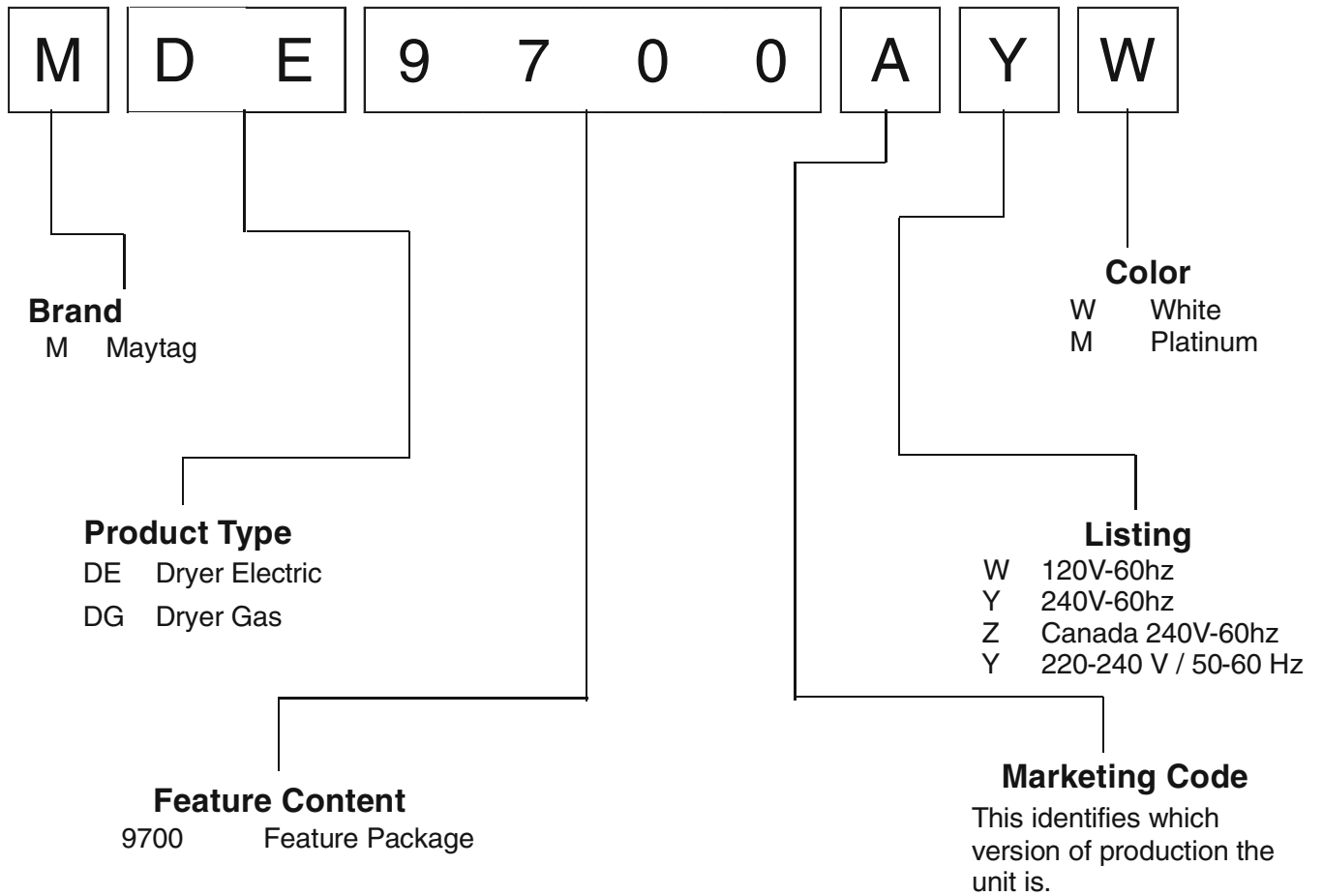

Troubleshooting Guide is Located on the back of the unit.



# Troubleshooting Procedures



## WARNING

To avoid risk of electrical shock, personal injury or death, disconnect power to unit before servicing, unless testing requires power.

Place dryer into Service Mode and check for diagnostic codes. See Technical Data Sheet taped to rear panel.

### Will Not Run

#### Will not start or run:

- All wires are hooked up to their corresponding terminals.
- Dryer is plugged in.
- Blown fuse or circuit breaker.
- Door switch functional...door closed. Check for error code 3 (See Table for code definition).
- Start/Pause rotary selector dial functional.
- Control Board operational.
- Drive motor functional.
- Check motor winding resistance: 2.88ohms between pin #3 and 4, 3.5ohms between pin #4 and 5.

#### Motor runs/ tumbler will not turn:

- Belt off or broken/damaged.
- Idler tension spring too weak or stretched.
- Idler pulley jammed or stuck.

#### Runs a few minutes and then stops:

- Lint buildup around drive motor.
- Low voltage present.
- Blower impeller blocked in blower housing.
- Drive motor - start switch contacts stuck closed.

#### Blows fuses or trips circuit breaker:

- The amperage readings are at 240 volts. One line will be 24 amps and the other line will be 21 amps. The neutral line will be at 3 amps. If the above amperages are present, then the house wiring, fuse box or circuit breaker should be suspect.
- Shorted heating element to housing.
- Incorrect wiring or a wire shorting to ground.
- Drive motor winding shorting to ground.

#### Gas Models

- During ignition the dryer will draw X amps. With the burner ON, the dryer will draw X amps. If the dryer is drawing amperages above this, then the house wiring, fuse box or circuit breaker is suspected to be at fault.
- Igniter harness loose and shorted to base.
- Incorrect wiring or wire shorted to ground.
- Drive motor winding shorting to ground.

### Will Not Dry

#### Will not heat (motor runs):

- Open heating element.
- Hi-Limit trips easily or is open.
- Regulating thermostat trips easily or is open.
- Membrane switch open.
- Check Thermistor.

### Will Not Dry Gas Models

#### Poor Gas Ignition

When the dryer is operated on a heat setting, the igniter should be energized and burner shall fire within 45 seconds at 120 VAC. The failure of a component in this system will usually be indicated by one of three symptoms:

**The igniter does not glow.** If the igniter does not heat up, remove power and using an ohmmeter, check the following:

- Open flame sensor
- Open igniter
- Shorted booster coil
- Open wiring
- Bad motor switch ( Neutral supply)
- No power from control ( L1 supply)

**Igniter glows - No gas ignition.** If the igniter heats up but the main burner flame is not ignited, remove power and using an ohmmeter, check the following:

- Open secondary coil
- Open holding coil
- Open wire harness
- Stuck flame sensor (Stuck closed)

**The gas is ignited but the flame goes out.** If a normal ignition takes place and after a short while the flame goes out, check for the following:

- Radiant sensor contacts opening prematurely.
- Weak gas valve coil may open when stressed by higher temperatures.
- Weak Hi-Limit
- Poor venting
- Bad drum seals

#### Improper drying/clothes wrinkled/ rough texture/long dry time:

- Lint filter is not clean.
- Restriction in exhaust.
- Outside exhaust hood damper door stuck closed.
- Exhaust too long, too many elbows, flex ductwork installed.
- Poor intake air available for the dryer.
- Incorrect tumbler speed. Tumbler belt slipping.
- Blower impeller bound; check for foreign material in blower area.
- Customer overloading dryer.
- Check clothing labels for fabric content and cycle selected.
- Clothes too wet due to insufficient spin out by washer.

#### Will Not Shut Off

- Check Membrane Pad.

# Troubleshooting Procedures



## WARNING

To avoid risk of electrical shock, personal injury or death, disconnect power to unit before servicing, unless testing requires power.

### Troubleshooting the electronic control circuit:

- Check for miswiring of the electrical connector at the electronic control board.

### Noisy and/Or Vibration

- **Thumping** Check for loose tumbler baffle, rear tumbler roller(s) worn or misaligned, out-of-round tumbler or high weld seam on tumbler.
- **Ticking** Check for loose wire harness or object caught in blower wheel area.
- **Scraping** Check for front or rear bulkhead felt seal out of position or worn tumbler front bearings.
- **Roaring** Check for blower wheel rubbing on blower housing or bad motor bearings.
- **Popping or squealing sound.** Check for a sticky or frayed belt.

## Service Mode

This mode provides Service Personnel the ability to verify the operation of the dryer.

The Service Mode can be implemented at any time, including the middle of a dry cycle. While in the Service Mode, the Technician can start special diagnostic tests such as a System Check Mode, LED Switch/Check, Display Software version number and display diagnostic/help code listings.

### Enter Service Mode:

Dryer must be on before Service Mode can be entered. Press **Chime** and **Temperature** Keys for 3 seconds, or until 3 beeps are heard. The machine will now be in Service Mode. Upon entry into Service Mode, the Sensor Bar Touch Data is to be displayed.

### Exit Service Mode

Press the **OFF** key to exit Service Mode or repeat the **Chime** and **Temperature** sequence.

### Diagnostic Tests

The following table lists the various tests available while in the Service Mode. Before advancing to the next test, the current test running must be terminated.

Press the following keys to access:

Key Press	Special Test/Function
<b>Wrinkle Prevent</b> Displays "d"	Display list of diagnostic codes.
Then rotate the <b>Cycle Selector Knob</b>	To sequence thru the diagnostic and help codes.
<b>Temperature Key</b>	Display software revision number
<b>Start/Pause</b>	Start or pause cycle running but remain in diagnostic mode. Display the number of cycles ago the diagnostic code occurred.

### System Check Mode

While in Service Mode, pressing the **Time** and **Wrinkle Prevent** keys for 3 seconds, will put the dryer into the System Check mode and "in" will display. The following table lists the various functions based on the keys being pressed.

### System Check Mode Table

Key Pressed:	Function Performed
<b>Start/Pause rotary selector dial</b>	Cycles the motor on/off.
Rotate the Cycle Selector Knob to <b>Delicates</b>	LED's and 7 segment display flash.
Rotate the Cycle Selector Knob to <b>Sensor Dry</b>	View current cycle temperature in Celsius.
Rotate the Cycle Selector Knob to <b>Wrinkle Control</b>	Segment display is "1" for sensor bar short, "0" for sensor bar open
Rotate the Cycle Selector Knob to <b>Time Dry</b>	View current cycle temperature in Fahrenheit.

# Troubleshooting Procedures



## WARNING

To avoid risk of electrical shock, personal injury or death, disconnect power to unit before servicing, unless testing requires power.

### LED/Switch Check

While in Service Mode, pressing the **Chime** and **Wrinkle Prevent** keys for 3 seconds, will start a LED/Switch Test. To exit the test at any point, press the same keys again for 3 seconds or press the **OFF** key to exit Service Mode.

Perform the check by pressing the keys, which toggle the LED's on and off.

All switch pads must be pressed within 5 minutes for this test to pass. **PR** will be displayed for five (5) seconds once all switch pads have been pressed and this test is completed. Following 10 seconds of inactivity at any point, the test will exit without any display. The **Power Off** switch pad must be pressed twice within thirty (30) seconds to cancel this test.

Switch	Action
Wrinkle Prevent	Press once
Chime	Press twice
Adjust Time	Press once
Time	Press four times
Temperature	Press three times
Dryness Level	Press four times
Selector Knob	Rotate 1 position
Start Pause	Press once
Off	Press once

### Diagnostic Codes

The Diagnostic Codes are identified when the severity level of the abnormality detected is higher and service may be required.

When a problem with the dryer is detected a Diagnostic Code is assigned, and can be displayed. The Control Board will not log multiple same codes per cycle; however, it will log as many Diagnostics as possible for the machine to continue running.

Access Diagnostic Codes by entering the Service Mode and pressing **Wrinkle Prevent**. A **d** will be displayed.

Rotate the Cycle Selector Knob in either direction to step through the list of codes one code at a time. Once an initial direction is selected by the user (either Clockwise or Counterclockwise), subsequent movements of the knob in the same direction will show older codes. If the user changes direction and turns the knob in the opposite direction, the more recent code will be displayed.

While a diagnostic code is displayed, if the **Start/Pause** button in the center of the Rotary Cycle Selector is pressed and held, the machine will display the number of cycles ago the diagnostic code occurred. When the **Start/Pause** button is released, the diagnostic code is again displayed.

### Clearing Diagnostic Codes

To clear the diagnostic code list press the **Sensor Dry Level** and **Time** keypads together for 3 seconds while viewing the list. The cycle count for each diagnostic code will be reset to 0, but not the machine cycle count.

### Diagnostic Codes

Code	Description	Trigger	Action Taken
1	Dryer Thermistor Short Sensed	The Thermistor resistance is very low.	<u>Check for:</u> <ul style="list-style-type: none"> <li>- Clogged lint screen.</li> <li>- Restricted vent system.</li> <li>- Check Thermistor resistance.</li> </ul>
2	Thermistor Open Sensed	The Thermistor resistance is very high	<u>Check for:</u> <ul style="list-style-type: none"> <li>- Low ambient temperature in room (Below 50°F/10°C).</li> <li>- Outside vent damper is stuck open in wintertime.</li> <li>- Loose or open wire terminals.</li> <li>- Check Thermistor resistance.</li> </ul>
3	Door Circuit Failure	Invalid state for more than 256 milliseconds	<u>Check for:</u> <ul style="list-style-type: none"> <li>- Loose or open wire terminals in Door Sense circuit.</li> </ul>
4	Possible motor transistor error	If either motor transistor is seen open or shorted during startup	<u>Check for:</u> <ul style="list-style-type: none"> <li>- Loose connections in motor circuit.</li> <li>- Run System Check Mode and check the motor relay function.</li> <li>- If relay functions, disregard the diagnostic code.</li> <li>- If relay does not function, replace machine control board.</li> </ul>

# Troubleshooting Procedures



## WARNING

To avoid risk of electrical shock, personal injury or death, disconnect power to unit before servicing, unless testing requires power.

Code	Description	Trigger	Action Taken
<b>8</b>	Stuck Key	A key is sensed to be pressed more than 75 seconds, the key shall be assumed to be stuck.	Run membrane pad check and replace console w/membrane pad if necessary.
<b>10</b>	No Wet Clothes	Sensor bar detects no wet clothes while a Sensor Dry Cycle	Check for: - Running dryer with no wet clothes in sensor dry cycle

### Display Fault/Error Codes







Display	Description	Trigger	Action Taken
<b>tS</b>	Dryer Thermistor Short Sensed	The Thermistor resistance is very low.	Check for: - Clogged lint screen. - Restricted vent system. - Check Thermistor resistance. - Check for diagnostic code 1
<b>do</b>	Door Open	Running the dryer with door open	Check for: - Close the door, and run the dryer - Loose or open wire terminals in Door Sense circuit. - Check for diagnostic code 3

<b>FE</b>	Power source frequency Error	Invalid power source Frequency	Check for: - Not using regular power source frequency - Invalid power frequency sense circuit
<b>dC</b>	Door Circuit Failure	Invalid state for more than 256 milliseconds	Check for: - Loose or open wire terminals in Door Sense circuit. - Check for diagnostic code 3
<b>hE</b>	Heater Error	Invalid heating temperature in running the dryer	Check for: - Restricted vent system. - Check Thermistor resistance.

# Component Testing Information

## ! WARNING



To avoid risk of electrical shock, personal injury or death, disconnect power to unit before servicing, unless testing requires power.

Illustration	Component	Test Procedure	Results
	Thermistor	Unplug harness connector and test from wire insertion side. Pin #2 and Pin #6 of CN6	10000 ohms @ 77° F/25° C
	Door Switch	Unplug connectors and test switch terminals.  Door open terminals COM to NC/ 1 to 3 Door open terminals COM to NO/1 to 2 Door closed terminals COM to NC/ 1 to 3 Door closed terminals COM to NO/ 1 to 2	Infinity  Less than 1 ohm  Infinity Less than 1 ohm
	Light	Unplug connectors and test switch terminals.  Check across terminals	80 to 100 ohms
	Belt Switch	Unplug connectors and test switch terminals.  Check across terminals switch closed Check across terminals switch open	Less than 1 ohm Infinity
	Motor	Unplug harness connector and test motor circuits.  Pin #4 and Pin #5 (Windings) Pin #1 and Pin #2 (Centrifugal switch)	2 ohms Open
	Thermostat 185° F/85° C 25A	Unplug connectors and test Thermostat terminals.  Check across terminals	Less than 1 ohm
	Hi Limit 210° F/99° C 25A	Unplug connectors and test Thermostat terminals.  Check across terminals	Less than 1 ohm
	Thermal Cut Off	Unplug connectors and test Thermostat terminals.  Check across terminals	Less than 1 ohm
	Heater Element	Unplug connectors and test Heater terminals	10 ohms

# Component Testing Information

## ⚠️ WARNING

To avoid risk of electrical shock, personal injury or death, disconnect power to unit before servicing, unless testing requires power.

Illustration	Component	Test Procedure	Results
	Sensor Bars	Unplug harness connector and test from wire insertion side.  Pin #4 to Pin # 5 of CN6	Infinity dry load 190ohms ± 10% wet load
	Radiant Sensor	Unplug connectors and test sensor terminals.	Closed
	TH2 Safety Thermostat	Unplug connectors and test Thermostat terminals.	Less than 1ohm
	Gas Valve	Unplug connectors and test valve terminals.  Check across terminals #1 and #3 (Booster Coil). Check across terminals #1 and #2 (Holding Coil). Check across terminals #2 and #3 (Both coils in series). Check across terminals #4 and #5 (Secondary Coil).	550ohms 1350ohms 1900ohms 1300ohms

### Motor Contacts

Function	1M	2M	3M	5M	6M
Start			●	●	
Run	●	●		●	●

● = Contact closed

Gas Valve



### Centrifugal Switch (Motor)

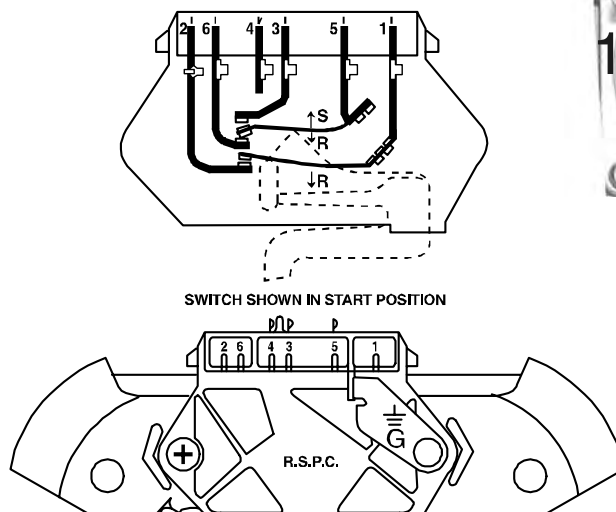

## Disassembly Procedures



**WARNING**

To avoid risk of electrical shock, personal injury or death; disconnect power to unit before servicing.

### Door Reversal/Disassembly

1. Disconnect power supply to unit.
2. Remove four screws and Door Strike.



3. Remove two screws attaching Door Hinge.



4. Install Door and Strike on opposite sides or continue with Door disassembly.
5. Remove screws around perimeter of Door Inner Panel.

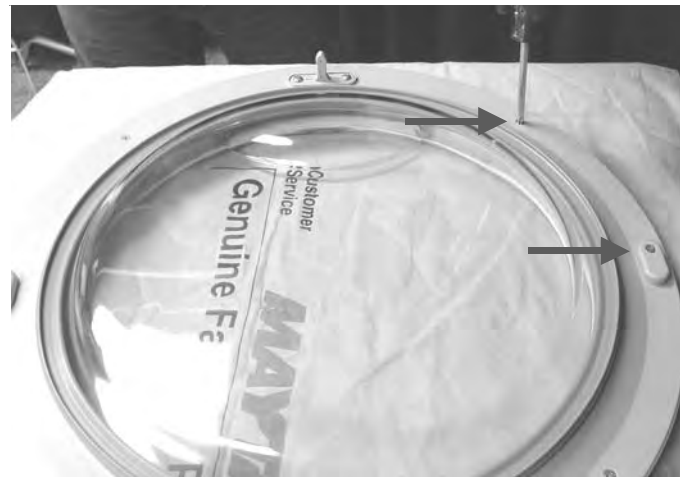

6. Remove Inner Panel.



7. Remove Gasket.





# Disassembly Procedures



## WARNING

To avoid risk of electrical shock, personal injury or death; disconnect power to unit before servicing.

8. Remove Inner Door Glass.



9. Remove outer door viewing panel. Insert screwdriver in slot to disengage latch.

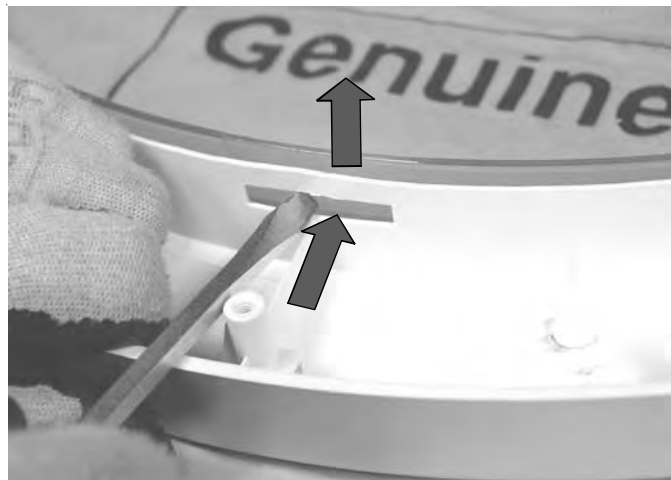

## Interior Light

1. Disconnect power supply to unit.
2. Remove Lens screw and Lens. Bulb is a screw in base 10W 120V AC.



## Top Removal

1. Disconnect power supply to unit.
2. Remove 2 10mm screws from dryer back.



3. Slide Top Cover towards the rear and lift from unit.



# Disassembly Procedures



**WARNING**

To avoid risk of electrical shock, personal injury or death; disconnect power to unit before servicing.

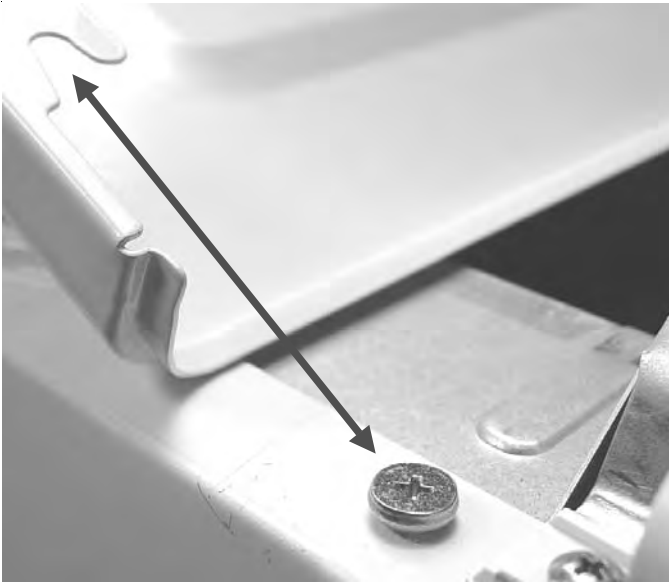

## Drum Baffle Removal

1. Disconnect power supply to unit.
2. Remove Top Cover.
3. Remove four screws located at the sound dampening seam.

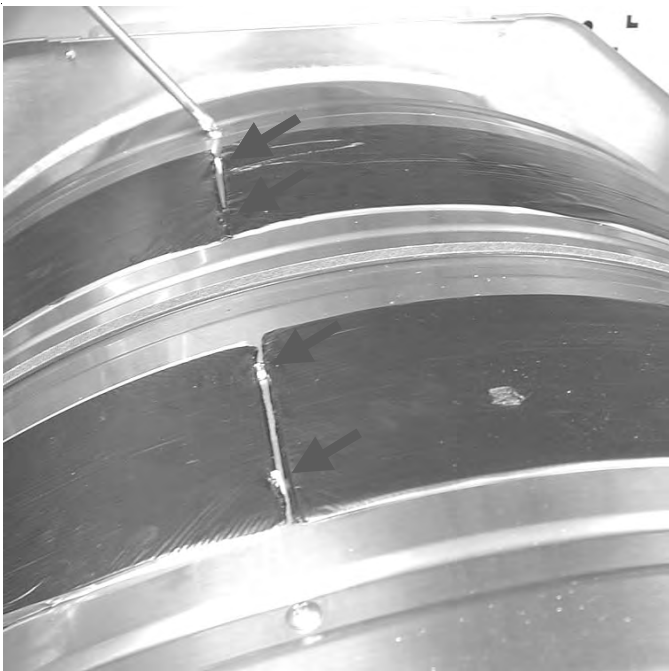

## Console Removal

1. Disconnect power supply to unit.
2. Remove Top Cover.
3. Remove two screws mounting the Heater PCB Board.



4. Disconnect the black and white connectors.

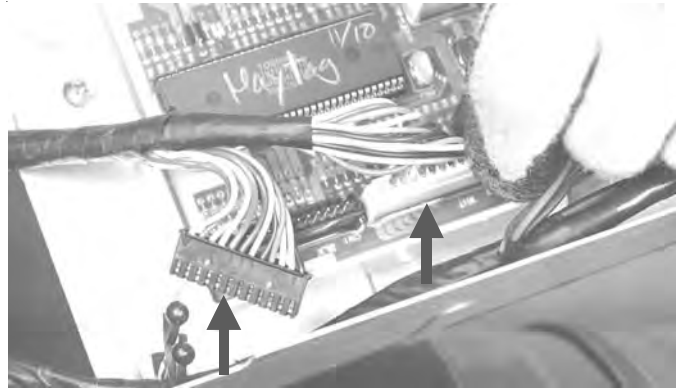

5. Remove four screws attaching Console to washer.



# Disassembly Procedures



## WARNING

To avoid risk of electrical shock, personal injury or death; disconnect power to unit before servicing.

6. Rotate Console down and remove from dryer.

### Front Panel Removal

1. Disconnect power supply to unit.
2. Remove Top Cover.
3. Remove Console.
4. Remove four screws attaching Front Panel to dryer.



5. Remove two screws in the door area.

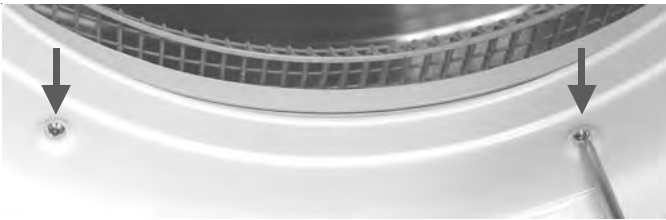

6. Pull Front Panel forward and disconnect the Interior Light harness.



7. Lift the Front Panel off the three tabs across the bottom and remove.

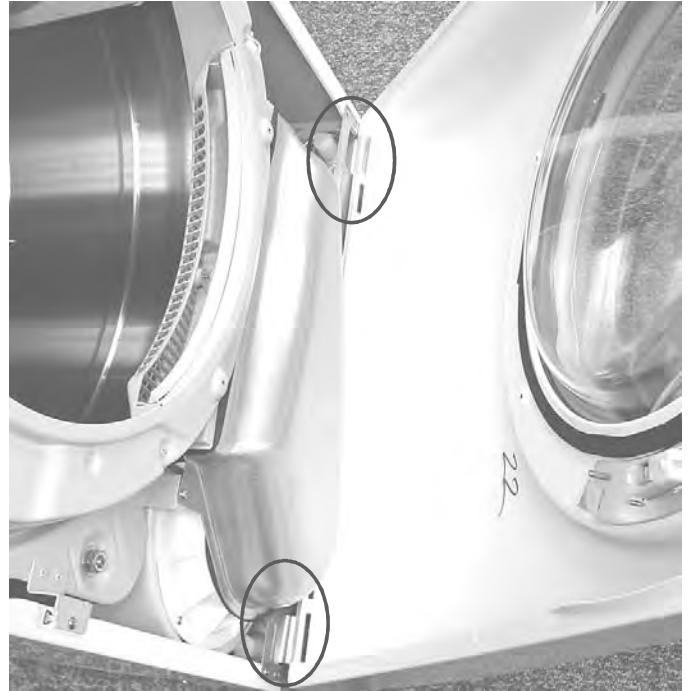

### Heater Assembly Removal

1. Disconnect power supply to unit.
2. Remove Top Cover.
3. Remove Console.
4. Remove Front Cover.
5. Remove Heater Assembly retaining screw.

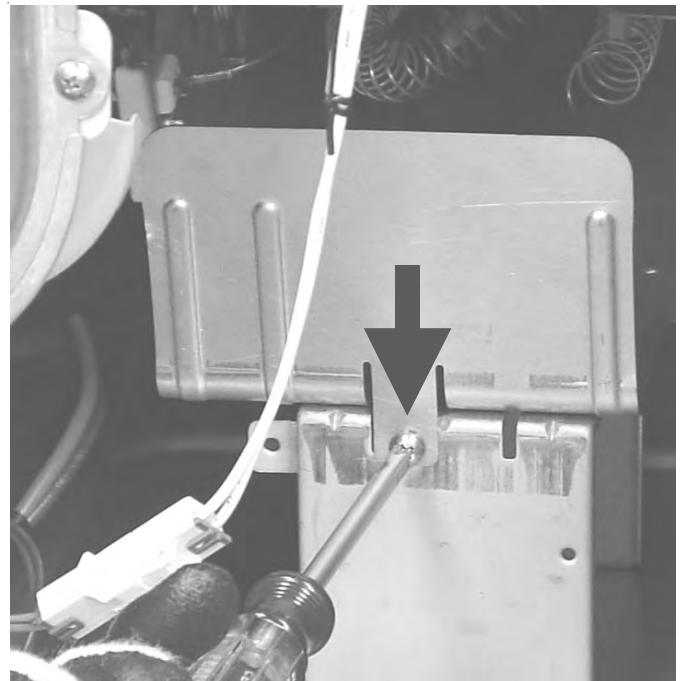

## Disassembly Procedures



### WARNING

To avoid risk of electrical shock, personal injury or death; disconnect power to unit before servicing.

6. Slide Heater Assembly out the front of dryer..



8. Reinstall by aligning the tabs on the back bulkhead with the notches in the Heater Assembly .

7. Remove the wiring terminals from the Heater Assembly.

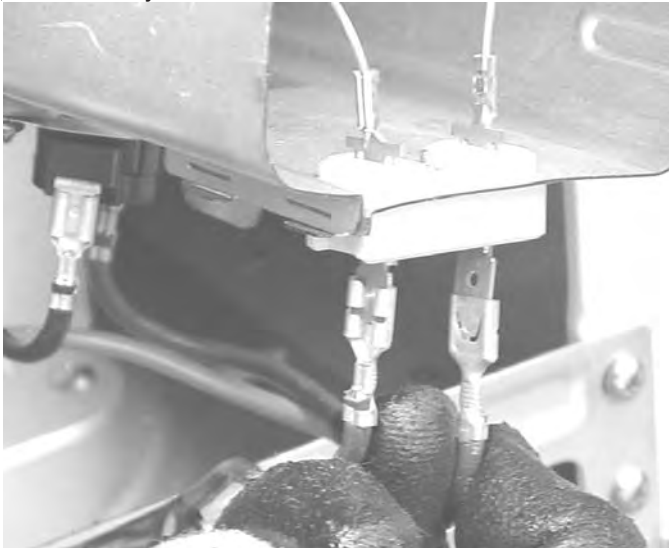

# Disassembly Procedures



**WARNING**

To avoid risk of electrical shock, personal injury or death; disconnect power to unit before servicing.

## Front Bulkhead Removal

1. Disconnect power supply to unit.
2. Remove Top Cover.
3. Remove Console.
4. Remove Front Panel.
5. Remove screws retaining Console Back Cover.



6. Disconnect Interior Light wiring harness.



7. Disconnect Moisture Sensor wiring harness.



8. Remove four Bulkhead retaining screws



## Disassembly Procedures



### WARNING

To avoid risk of electrical shock, personal injury or death; disconnect power to unit before servicing.

9. Lift Bulkhead from Cabinet and remove.



6. Remove sensor attachment screw.



### Moisture Sensor Removal

1. Disconnect power supply to unit.
2. Remove Top Cover.
3. Remove Console.
4. Remove Front Panel.
5. Disconnect Moisture Sensor wire harness.



### Belt Removal

1. Disconnect power supply to unit.
2. Remove Top Cover.
3. Remove Console.
4. Remove Front Panel.
5. Remove belt from Idler Pulley

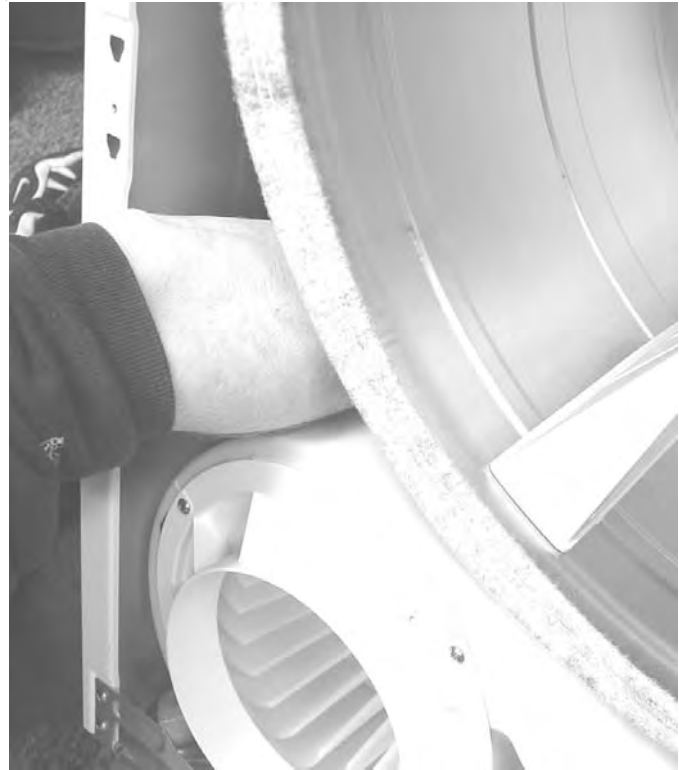

## Disassembly Procedures



**WARNING**

To avoid risk of electrical shock, personal injury or death; disconnect power to unit before servicing.

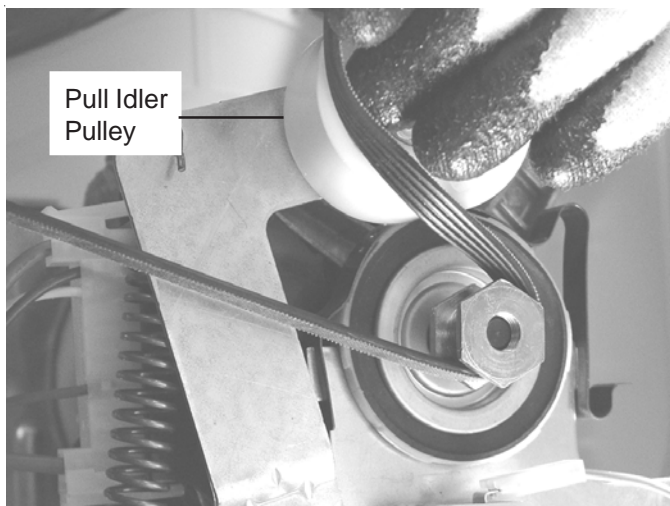

### Belt Switch Removal

1. Disconnect power supply to unit.
2. Remove five screws retaining Vent Tube cover.

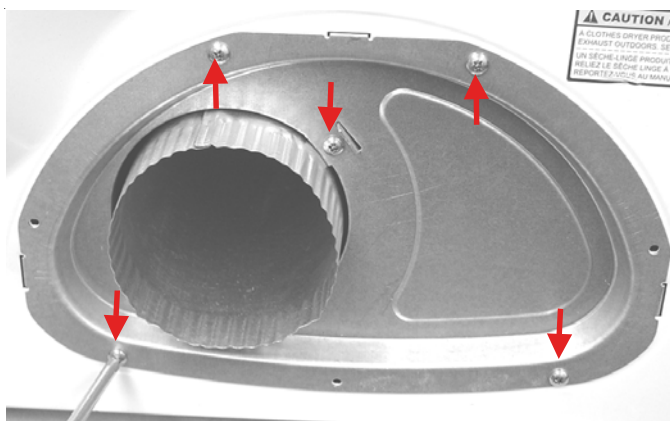

3. Remove Belt Switch mounting screw.

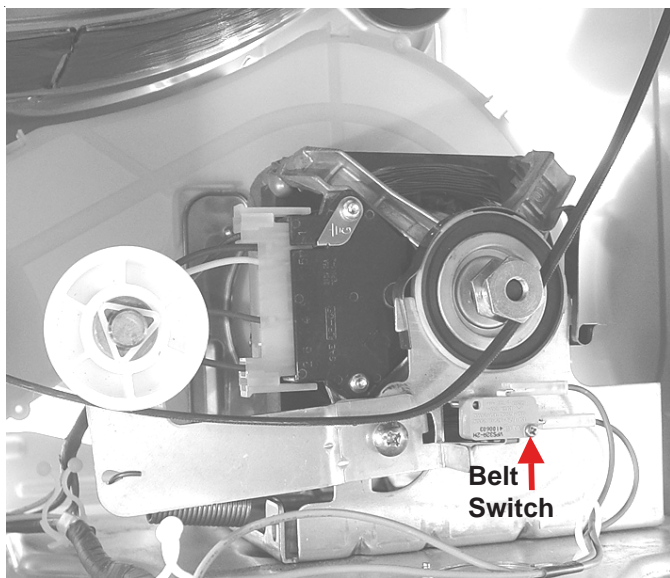

### Drum Removal

1. Disconnect power supply to unit.
2. Remove Top Cover.
3. Remove Console.
4. Remove Front Panel.
5. Remove Console Back Cover.
6. Remove Front Bulkhead.
7. Remove belt from Idler Pulley.
8. Grasp the Drum with one hand and the belt with the other. Lift the Drum and slide out the front. Carefully spread the cabinet as needed to gain additional clearance.



### Motor/Blower Assembly Removal

1. Disconnect power supply to unit.
2. Remove Top Cover.
3. Remove Console.
4. Remove Front Panel.
5. Remove Console Back Cover.
6. Remove Belt from Idler Pulley.
7. Remove Drum.
8. Remove the two screws securing the Blower Intake Panel to the Blower Housing. Remove Blower Intake Panel.

## Disassembly Procedures

 **WARNING**

To avoid risk of electrical shock, personal injury or death; disconnect power to unit before servicing.

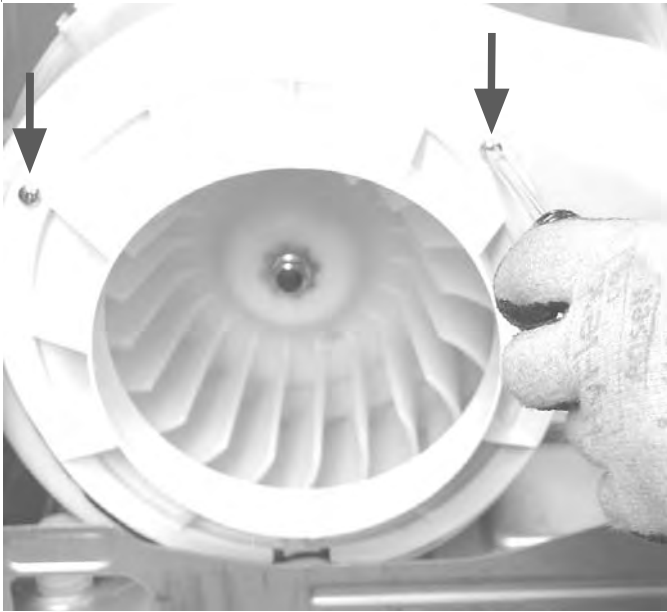

9. Removed the screw at the bottom of the blower housing.



10. Remove the blower attachment screw under the Thermistor.

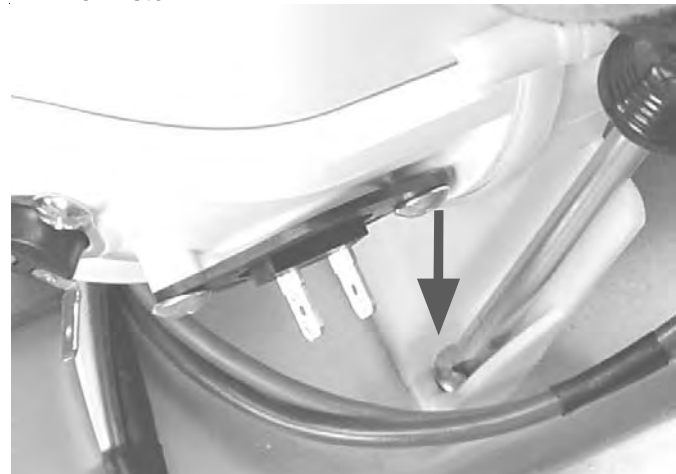

11. Remove two screws attaching the motor bracket to the base.

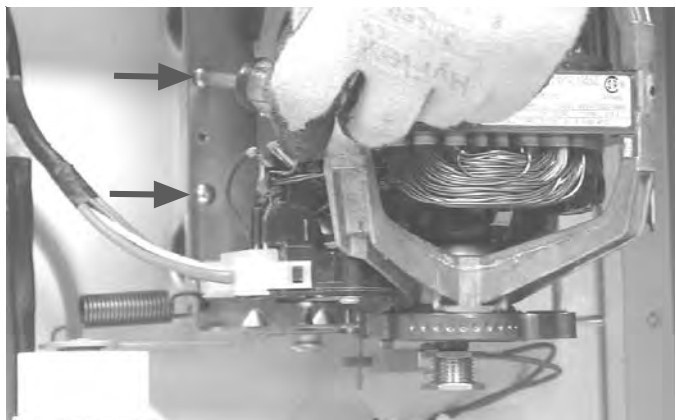



## Disassembly Procedures



### WARNING

To avoid risk of electrical shock, personal injury or death; disconnect power to unit before servicing.

12. Disconnect the Motor wire harness and the two wires to the belt switch.

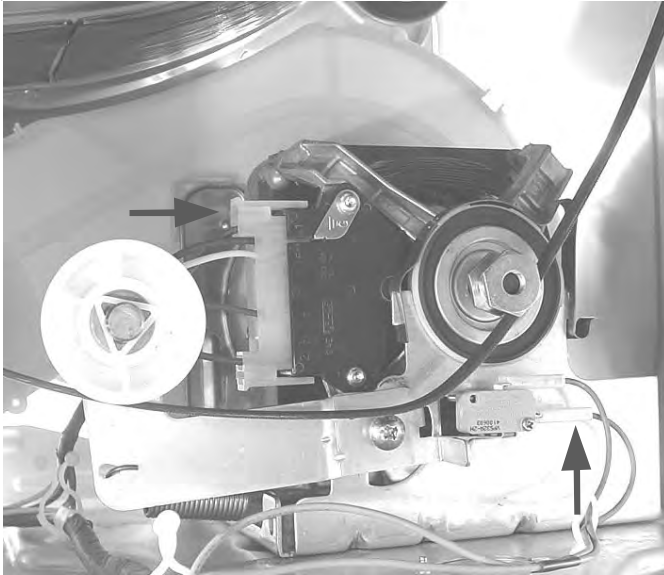

13. Slide the Motor Blower Assembly toward the heater and lift to disengage the tabs on the motor from the slots in the base.



14. Remove the 14mm nut securing the blower wheel to the shaft. The nut is a left hand thread.

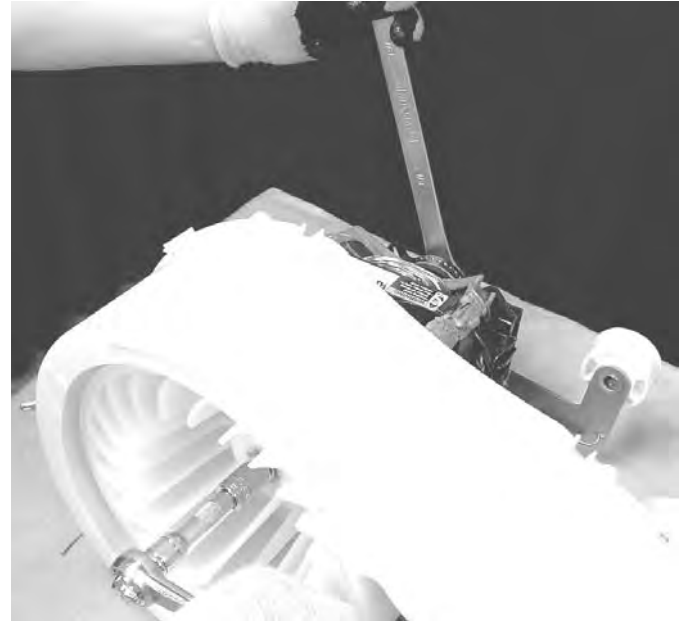

**NOTE:** A wrench can be placed on both ends of the Motor Output Shaft.

15. Remove Blower Wheel.



16. Remove the three screws securing the blower housing to the motor bracket.

# Disassembly Procedures



**WARNING**

To avoid risk of electrical shock, personal injury or death; disconnect power to unit before servicing.

17. Remove the three screws securing the blower housing to the motor bracket .

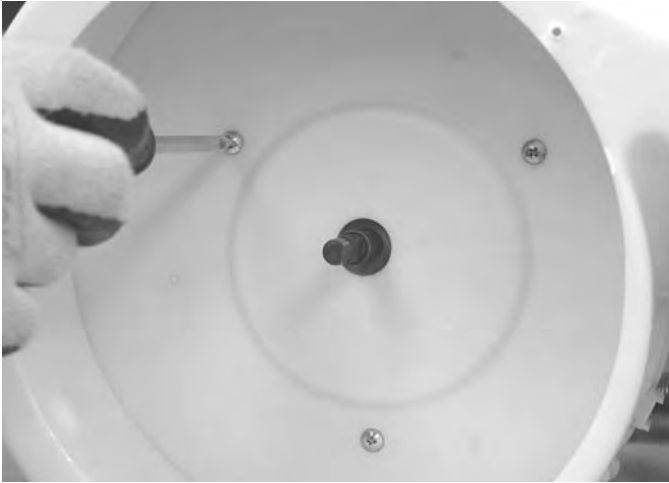

18. Use a wide blade screwdriver to pop off the motor retention clamps.

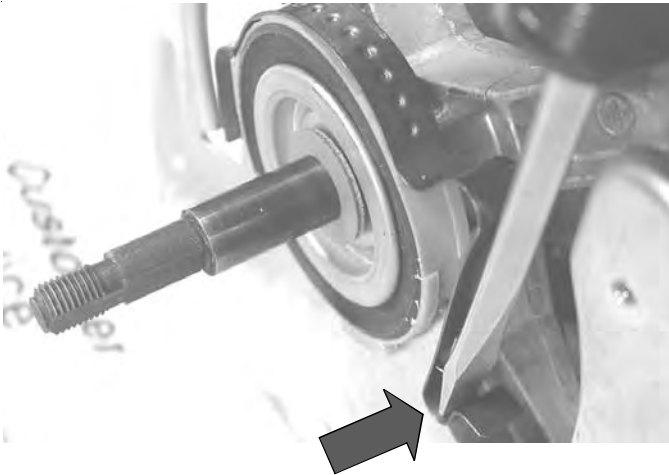

## Rear Bulkhead Removal

1. Disconnect power supply to unit.
2. Remove Top Cover.
3. Remove Console.
4. Remove Front Panel.
5. Remove Console Back Cover.
6. Remove Belt from Idler Pulley.
7. Remove Drum.
8. Remove 7 screws from the back.

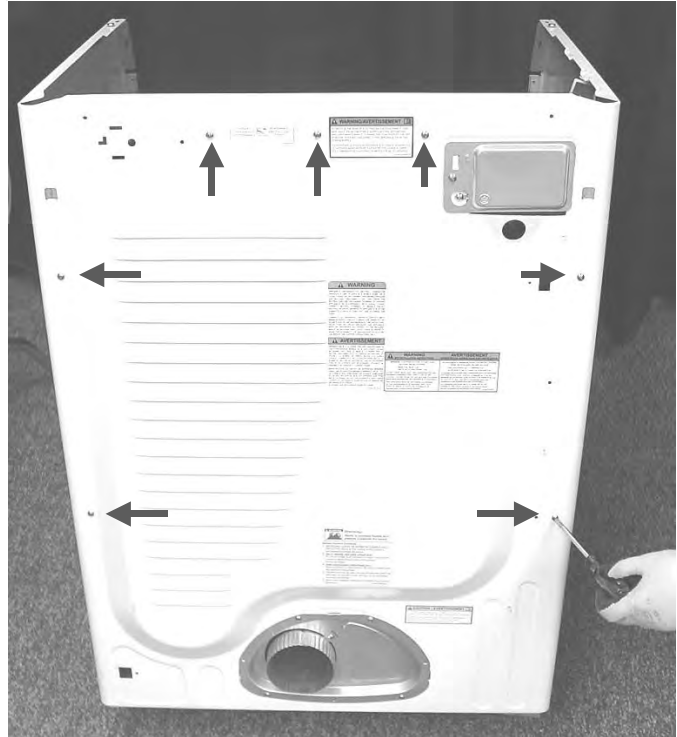

9. Lift the rear bulkhead off the right and left side hangers.

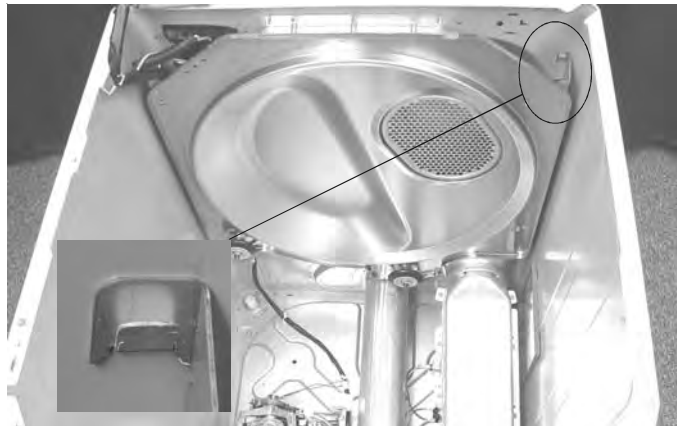

# Disassembly Procedures



**WARNING**

To avoid risk of electrical shock, personal injury or death; disconnect power to unit before servicing.

## Rear Roller Removal

1. Disconnect power supply to unit.
2. Remove Rear Bulkhead.
3. Remove Roller Keeper and nut.

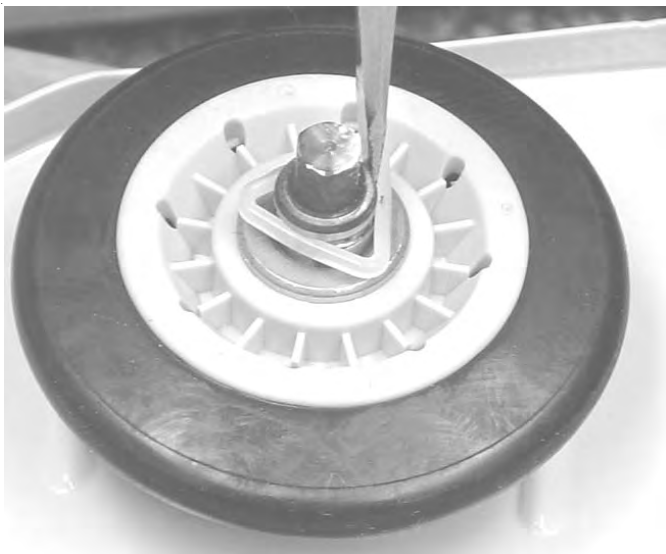

## Gas Model Disassembly

### Igniter Removal

1. Disconnect power supply to unit.
2. Remove Top Cover.
3. Remove Console.
4. Remove Front Panel.
5. Loosen the single screw attaching the igniter to the Burner Assembly. Slide the Igniter back and remove.

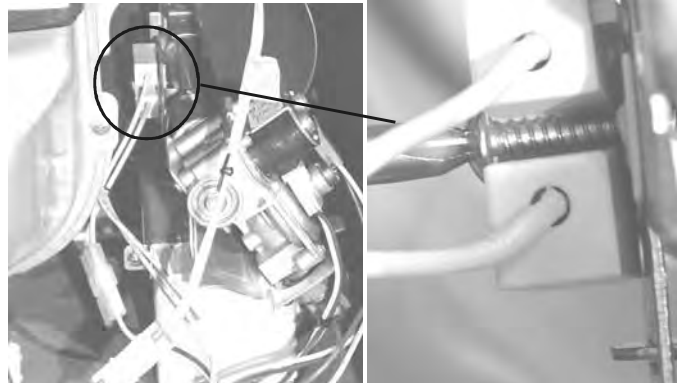

# Disassembly Procedures

**WARNING**

To avoid risk of electrical shock, personal injury or death; disconnect power to unit before servicing.

**WARNING**

To avoid risk of personal injury or death; shut off gas supply to unit before servicing Burner Assembly.

NOTE: The Igniter Bar is fragile. Be careful not to damage Igniter when removing Burner Assembly.

## Burner Removal

1. Disconnect power supply to unit.
2. Shut off gas supply.
3. Disconnect gas line.

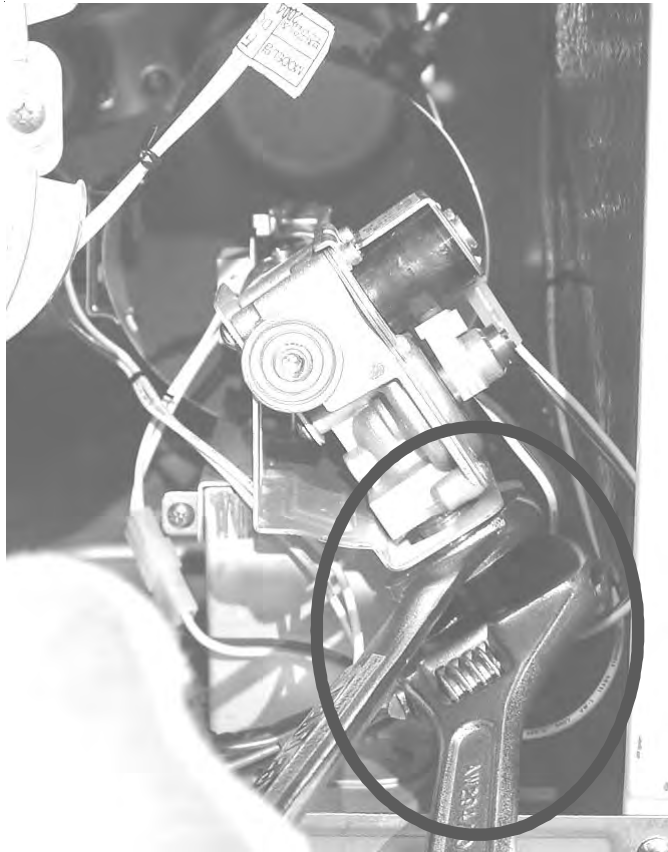

4. Remove two screws securing burner to bracket.

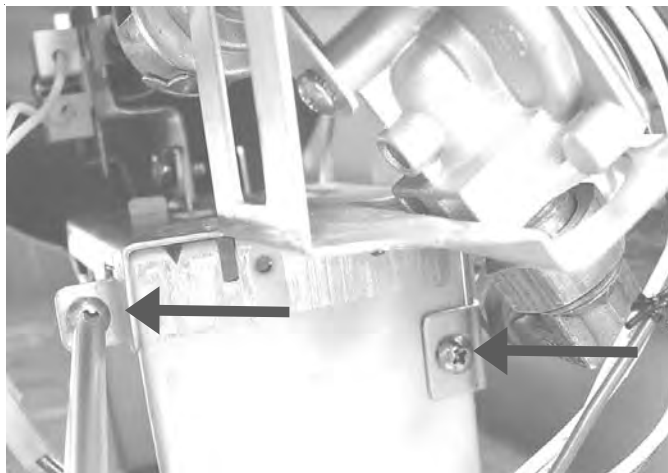

5. Remove the two screws attaching the housing to the burner bracket. The screws are recessed from view.

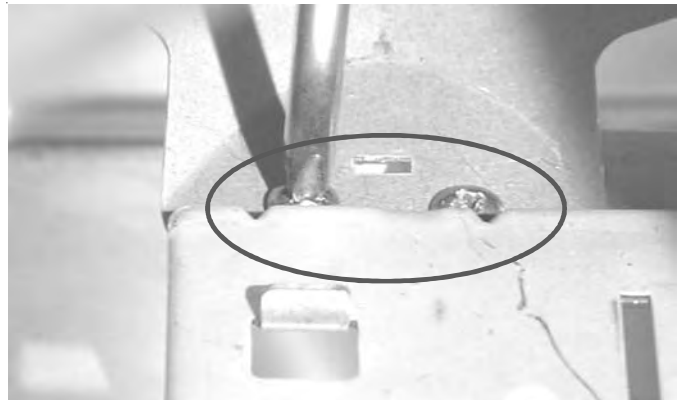

6. Slide Burner Assembly from dryer.

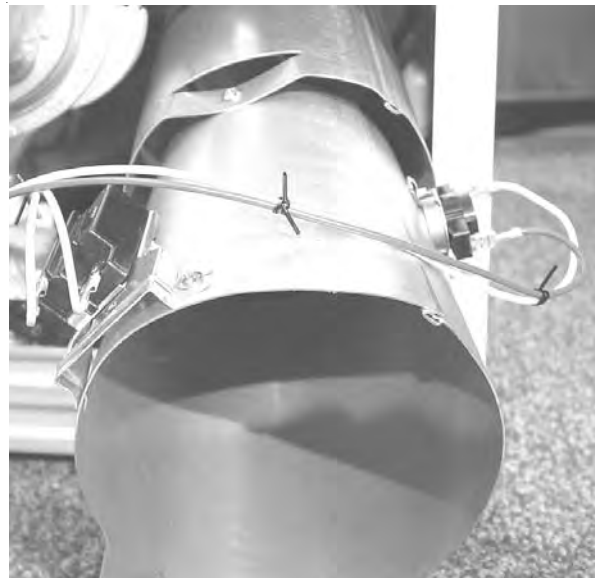

# Appendix A



AUTOMATIC DRYER INSTALLATION INSTRUCTIONS  
MISE EN SERVICE SÉCHEUSE AUTOMATIQUE  
INSTRUCCIONES DE INSTALACIÓN DE LA SECADORA  
AUTOMÁTICA

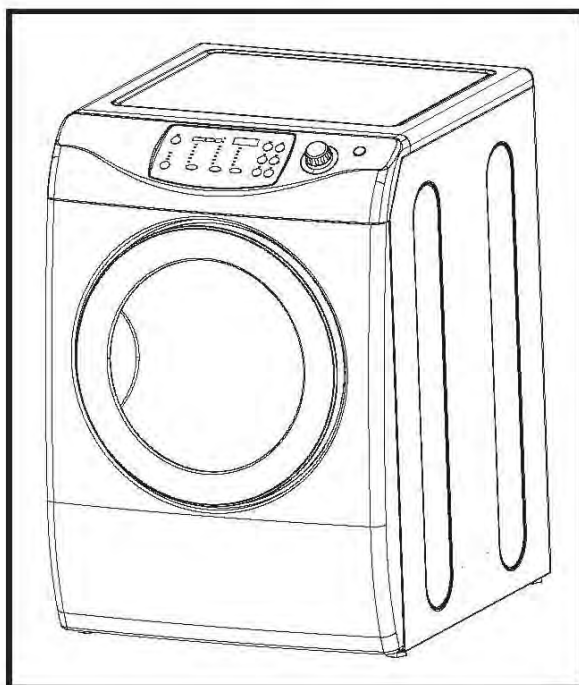

*The installation, including a proper exhaust system,  
is the responsibility of the owner.*

*La responsabilité de la mise en service, y compris le système  
d'évacuation qui convient, revient au propriétaire.*

*Es responsabilidad del propietario la instalación correcta,  
incluso la del sistema de escape.*

**LEAVE THESE INSTRUCTIONS WITH THE OWNER  
REMETTRE CES INSTRUCTIONS AU PROPRIÉTAIRE  
DEJE ESTAS INSTRUCCIONES CON EL PROPIETARIO**

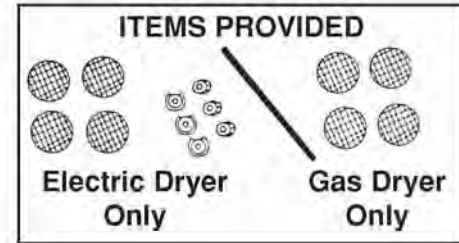

**Proper installation is the responsibility of the owner.**

**HOWEVER, SERVICE CALLS PERFORMED AS A RESULT OF POOR SET-UP, ADJUSTMENT AND CONNECTION ARE THE RESPONSIBILITY OF THE INSTALLER.**

Make sure you have everything necessary for proper installation.

1. GROUNDED ELECTRICAL OUTLET is required. See Electric Requirements.
2. POWER CORD for electric dryers (except Canada).
3. GAS LINES (if a gas dryer) must meet National and Local Codes.
4. EXHAUST SYSTEM – must be rigid metal or flexible stiff walled metal exhaust ducting. See Exhaust Requirements.

## CABINET DIMENSIONS

DRYER DIMENSIONS	INCH (CM)
A. Height-overall	38" (96.5)
B. Width	27" (68.6)
C. Depth-With Dryer Door Open 90°	49-3/8" (125.4)
D. Depth	30-3/8" (77.2)
E. Bottom Vent Hole Location - From Back To Center of Hole	7-1/2" (19)
Side Vent Hole - From Back To Center Of Hole	8-1/2" (21.6)

**Note:**

The height of the dryer from top to floor is 38" with the leveling leg screwed all the way in. The customer can unscrew the leg out an additional 7/8" for a total overall height of 38 7/8".

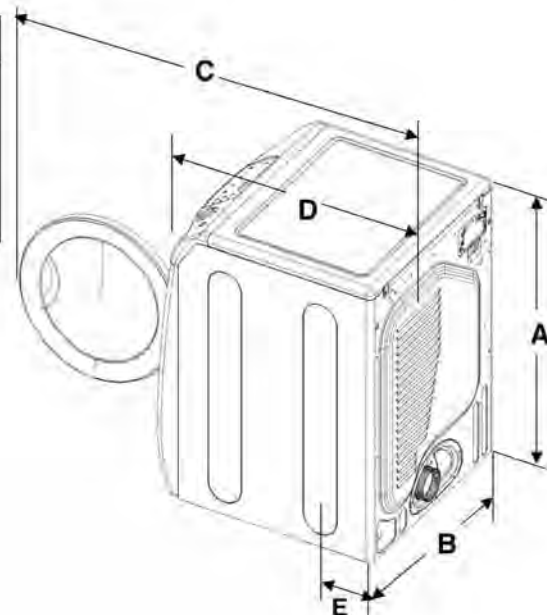

## IMPORTANT TO INSTALLER

Please Read The Following Instructions Carefully Before Starting To Install The Dryer. These Instructions Should Be Retained For Future Reference.

**REMOVE THE DOOR FROM ALL DISCARDED APPLIANCES SUCH AS DRYERS TO AVOID THE DANGER OF A CHILD SUFFOCATING.**

# LOCATION CONSIDERATIONS

The dryer should be located to permit adequate room in front for loading the dryer, and sufficient room behind the dryer for the exhaust system.

This dryer is factory-ready for rear exhaust. To exhaust out the bottom or left side, use the accessory exhaust kit (see Accessories). Instructions are included with the kit.

It is important to make sure the room has adequate make-up air. The area where the dryer is located must not obstruct the flow of combustion or ventilating air.

On gas dryers, adequate clearance as noted on the data plate must be maintained to insure adequate air for combustion and proper operation of the dryer.

THE DRYER **MUST NOT** BE INSTALLED OR STORED IN AN AREA WHERE IT WILL BE EXPOSED TO WATER AND/OR WEATHER. THE DRYER AREA IS TO BE KEPT CLEAR AND FREE FROM COMBUSTIBLE MATERIALS, GASOLINE AND OTHER FLAMMABLE VAPORS AND LIQUIDS. A DRYER PRODUCES COMBUSTIBLE LINT. THE AREA AROUND THE DRYER SHOULD BE KEPT FREE OF LINT.

## ALCOVE OR CLOSET INSTALLATION



- An appliance installed in a closet shall have no other fuel-burning appliance installed in the same closet.
- **WARNING: To reduce the risk of fire, this dryer MUST BE EXHAUSTED TO THE OUTDOORS.** See EXHAUST INFORMATION section.

- Minimum clearances between dryer cabinet and adjacent walls or other surfaces are:  
2" front, 17" top, 0" either side and 2-3/8" rear.
- Closet front must have two unobstructed air openings combined total area 72 in<sup>2</sup> min., located 3 in min. from top and bottom.  
Louvered door with equivalent air opening is acceptable.

## MOBILE HOME INSTALLATION

The installation of the dryer in mobile homes must conform to the Manufactured Home Construction and Safety Standard Title 24 CFR, Part 32-80 {formerly the Federal standard for Mobile Home Construction and Safety, Title 24, HUD (Part 280), 1975} for the United States,) or CSA Standards Z240 (for Canada). When installing a dryer in a mobile home, provisions for anchoring the dryer to the floor must be made. An anchor bracket kit is available with instructions (see Accessories). Locate in an area that has adequate make up air. A minimum of 72 in<sup>2</sup> (183 cm<sup>2</sup>) of unobstructed opening is required. All mobile home installations must be exhausted to the outside with the exhaust duct termination securely fastened to the mobile home structure, using materials that will not support combustion. The exhaust duct may not terminate beneath the mobile home. See the section on exhausting for more information.



## EXHAUSTING

Exhausting the dryer to the outside will prevent large amounts of lint and moisture from being blown into the room.

### In the United States:

- All gas dryers must be exhausted to the outside.
- Electric dryers located in a confined area such as a bedroom, bathroom, or closet must be exhausted to the outside.
- Electric dryers not located in a confined area may be exhausted to the inside (see nonexhausted installations).

### In Canada:

- All dryers must be exhausted to the outside.

### Outside the U.S. and Canada:

- Refer to local codes.



**WARNING** – plastic or nonmetal flexible duct presents a potential fire hazard.

**NEVER USE PLASTIC OR NONMETAL FLEXIBLE DUCT.**

If your existing ductwork is plastic, nonmetal or combustible, replace it with metal. Use only metal exhaust duct that will not support combustion to insure the containment of exhaust air, heat and lint.

## DUCTING REQUIREMENTS

- Use A Minimum Of 4-inch (10.2 Cm) Diameter Rigid Aluminum Or Rigid Galvanized Steel Duct.
- Do not use smaller duct.
- Ducts larger than 4 inches (10.2 cm) in diameter can result in increased lint accumulation. Lint accumulation should be cleaned regularly.
- If flexible metal duct must be used, use the type with a stiff sheet metal wall. Do not use flexible duct with a thin foil wall. Serious blockage can result if flexible metal duct is bent too sharp.
- Never install any type of flexible duct in walls, ceilings or other concealed spaces.
- Keep exhaust duct as straight and short as possible.
- Secure joints with duct tape. Do not use screws.
- DO NOT EXHAUST DRYER INTO ANY WALL, CEILING, CRAWL SPACE OR A CONCEALED SPACE OF A BUILDING, GAS VENT, ANY OTHER COMMON DUCT OR CHIMNEY. THIS COULD CREATE A FIRE HAZARD FROM LINT EXPELLED BY THE DRYER.
- Plastic flexible duct can kink, sag, be punctured, reduce airflow, extend drying times and affect dryer operation.

ELECTRIC AND GAS DRYER				
Weather Hood Type				
Recommended			Use only for short run installation	
4" (10,16 cm)			2 1/2" (6,35 cm)	
No. of 90° elbows	Rigid	Metallic Flexible*	Rigid	Metallic Flexible*
0	24.4 m (80 ft.)	12.4 m (41 ft.)	22.6 m (74 ft.)	10.1 m (33 ft.)
1	20.7 m (68 ft.)	11.2 m (37 ft.)	18.9 m (62 ft.)	8.8 m (29 ft.)
2	17.4 m (57 ft.)	10.1 m (33 ft.)	15.5 m (51 ft.)	7.6 m (25 ft.)
3	14.3 m (47 ft.)	9.0 m (29 ft.)	12.5 m (41 ft.)	6.5 m (21 ft.)

\* Do not use non metallic flexible duct.

- Exhaust systems longer than recommended can extend drying times, affect machine operation and may collect lint.
- The exhaust duct should end with an exhaust hood with a swing out damper to prevent back drafts and entry of wildlife. Never use an exhaust hood with a magnetic damper.
- The hood should have at least 12 inches (30.5 cm) of clearance between the bottom of the hood and the ground or other obstruction. The hood opening should point down. Never install a screen over the exhaust outlet.
- When possible, do not exhaust the dryer directly into a window well in order to avoid lint build-up. Do not exhaust under a house or porch.
- If exhaust ductwork must run through an unheated area, the duct should be insulated and slope slightly down towards the exhaust hood to reduce condensation and lint build-up.
- Inspect and clean the interior of the exhaust system at least once a year. Disconnect electrical service prior to cleaning.
- Frequently check to be sure the exhaust hood damper opens and closes freely.

### **If new dryer is installed into an existing exhaust system you must be sure:**

- The exhaust system meets all local, state and national codes.
- That plastic flexible duct is not used.
- Inspect and clean all lint accumulation from the interior of the existing duct.
- The duct is not kinked or crushed.
- The exhaust hood damper opens and closes freely.

**The static pressure in any exhaust system must not exceed 0.83 inches of water column, or be less than 0.**

This can be measured with the dryer running with a manometer at the point where the exhaust duct connects to the dryer. A no heat setting should be used. The dryer tumbler should be empty and the lint filter clean.

# NONEXHAUSTED INSTALLATIONS

- If the electric dryer is not exhausted to the outside, the exhaust must not terminate directly behind the dryer.
- Use a rectangular vent kit along with a Dacron mesh lint bag (see Accessories). Maintain a 6" (15.2 cm) clearance between the back of the dryer and the wall. Although the lint screen and lint bag will retain most of the lint, a certain amount will be expelled into the laundry area.
- **WARNING: IF THE DRYER IS NOT EXHAUSTED TO THE OUTSIDE, SOME FINE LINT WILL BE EXPELLED INTO THE LAUNDRY AREA. AN ACCUMULATION OF DUST OR LINT IN ANY AREA OF THE HOME CREATES A FIRE HAZARD. ANY LINT ACCUMULATIONS MUST BE CLEANED FREQUENTLY.**

## GAS REQUIREMENTS

Use only Natural or LP (liquid propane) gases.

**THE INSTALLATION MUST CONFORM WITH LOCAL CODES, OR IN THE ABSENCE OF LOCAL CODES, WITH THE NATIONAL FUEL GAS CODE ANSI/Z223.1, LATEST REVISION (FOR THE UNITED STATES), OR WITH THE CAN/CGA-B149 INSTALLATION CODES (FOR CANADA).**

Gas dryers are equipped with a burner orifice for operation on NATURAL gas. **If the dryer is to be operated on LP (liquid propane) gas, it must be converted for safe and proper performance and must be converted by a qualified service technician.** Conversion kits from NATURAL to LP, or LP to NATURAL are available through your local Maytag dealer (see Accessories). If other conversions are required, check with the local gas utility for specific information concerning conversion requirements.

A 1/2" (1.27 cm) gas supply line is recommended and must be reduced to connect to the 3/8" (1.0 cm) gas line on the dryer.

The National Fuel Gas Code requires that an accessible, approved manual gas shut off valve be installed within 6 feet of the dryer.

**Gas Dryers installed in residential garages must be elevated 18 inches (46 cm) above the floor.**

Additionally, a 1/8" (.3 cm) N.P.T. (National Pipe Thread) plugged tapping, accessible for test gauge connection, must be installed immediately upstream of the gas supply connection to the dryer.

The dryer must be disconnected from the gas supply piping system during any pressure testing of the system.

**DO NOT** re-use old flexible metal gas line. Flexible gas line must be design certified by American Gas Association (CGA in Canada). **NOTE:** Any pipe joint compound used must be resistant to the action of any liquefied petroleum gas.

**NOTE:** As a courtesy, most local gas utilities will inspect a gas appliance installation.

### GAS IGNITION –

This dryer uses an automatic ignition system to ignite the burner. **There is no constant burning pilot.**

#### COMMONWEALTH OF MASSACHUSETTS INSTALLATION INSTRUCTIONS

This gas dryer must be installed by a licensed plumber or gas fitter

A "T" handle manual gas valve must be installed in the gas supply line to this gas dryer.

If a flexible gas connector is used to install this gas dryer, the connector must have a maximum length of 3 feet. (36 inches)



#### WARNING

Gas leaks may occur in your system and result in a dangerous situation. Gas leaks may not be detected by smell alone. Gas suppliers recommend you purchase and install a UL approved gas detector. Install and use in accordance with the manufacturer's instructions.

# ELECTRICAL REQUIREMENTS

**NOTE:** Wiring diagram is located below the Top Cover.

**Export models** (not U.S. or Canada): See Additional Instructions for Export Models on the other side of this sheet.



- Improper connection of the equipment grounding conductor can result in a risk of electric shock. Check with a qualified electrician or serviceman if you are in doubt as to whether the appliance is properly grounded. Do not modify the plug provided with the appliance – if it will not fit the outlet, have a proper outlet installed by a qualified electrician.
- To prevent unnecessary risk of fire, electrical shock or personal injury, all wiring and grounding must be done in accordance with local codes, or in the absence of local codes, with the National Electrical Code, ANSI/NFPA No. 70-Latest Revision (for the US) or the Canadian Electrical Code CSA C22.1 - Latest Revisions and local codes and ordinances. It is the personal responsibility and obligation of the appliance owner to provide adequate electrical services for this appliance
- All gas installations must be done in accordance with the national Fuel Code ANSI/Z2231 - Last revision (for United States) or CAN/CGA - B149 Installation Codes - Latest Revision (for Canada) and local codes and ordinances.

## GROUNDING

This dryer must be grounded. In the event of malfunction or breakdown, the ground will reduce the risk of electrical shock by providing a path of least resistance for electrical current.

## GAS MODELS

This appliance is equipped with a cord having an equipment-grounding conductor and a grounding plug. The plug must be plugged into an appropriate outlet that is properly installed and grounded in accordance with all local codes and ordinances.

Do not modify the plug provided with the appliance – if it will not fit the outlet, have a proper outlet installed by a qualified electrician.

If a separate ground is required by local codes, a grounding kit (Part No. 12001875) is available. It contains ground wire, clamp, ground screw and washer. Connect ground wire to back of unit with the cabinet ground screw and washer. Secure other end of ground wire to a suitable external ground connection. The wire may be secured with the clamp to a grounded COLD metal water pipe.

**NEVER CONNECT GROUND WIRE TO PLASTIC PLUMBING LINES, GAS LINES OR HOT WATER PIPES.**

## ELECTRIC MODELS

This appliance is equipped with a cord having an equipment-grounding conductor and a grounding plug. The plug must be plugged into an appropriate outlet that is properly installed and grounded in accordance with all local codes and ordinances.

If a power cord is not used and the electric dryer is to be permanently wired, the dryer must be connected to a grounded metal, permanent wiring system; or an equipment grounding conductor must be run with the circuit conductors and connected to the equipment grounding terminal.

# ELECTRICAL CONNECTIONS

**BEFORE OPERATING OR TESTING**, follow all grounding instructions in Grounding Section.

An individual branch (or separate) circuit serving only this appliance is recommended. **DO NOT USE AN EXTENSION CORD.**

## **GAS MODELS – U.S. and Canada**

A 120 volt, 60 Hz AC, approved electrical service, with a 15 ampere fuse or circuit breaker is required.

## **ELECTRIC MODELS – U.S. Only**

Most U.S. dryers, as manufactured, require a 120/240 volt, 60 Hz AC approved electrical service. Some require 120/208 volt, 60 Hz approved electrical service. The electric service requirements can be found on the data label located on the front behind the door. A 30 ampere fuse or circuit breaker on both sides of the line is required.

- A 120/240-volt U.S. electric dryer must be converted if it is to operate on a 120/208 volt electrical system.
- If a power cord is used, the cord should be plugged into a 30-ampere receptacle.
- The power cord is **NOT** provided with U.S. electric model dryers.

**IMPORTANT:** When permitted by local codes, the dryer electrical supply may be connected by means of a new power supply cord kit, marked for use with clothes dryer, that is U.L. listed, rated at 120/240 volts minimum, 30 amperes with three No. 10 copper wire conductors terminated with closed loop terminals, open-end spade lugs with turned up ends or with tinned leads.

- Do not reuse a power supply cord from an old dryer. The power cord electric supply wiring must be retained at the dryer cabinet with a suitable UL listed strain relief.
- If the dryer is to be installed in a mobile home or an area where local codes do not permit grounding through neutral, only a 4 conductor power cord, rated and terminated as above, may be used.  
(Use 4-prong plug for 4 wire receptacle, NEMA type 14-30R)

## **ELECTRIC MODELS - Canada Only**

- A 120/240 volt, 60 Hz AC approved electrical service fused through a 30 ampere fuse or circuit breaker on both sides of the line is required.
- All Canadian models are shipped with the power cord attached. The power cord should be plugged into a 30 ampere receptacle.

**NOTE:** It is not permissible to convert a dryer in Canada to 208 volts.

## **REPLACEMENT PARTS AND ACCESSORIES**

If your dryer requires replacement parts or accessories, contact the dealer from whom you purchased your dryer or Maytag Customer Service, Box 2370, Cleveland, Tennessee 37320-2370, phone 423-472-3333, for information on the nearest authorized Maytag Parts Distributor.

# INSTALLATION

**Parts and literature are packaged inside of dryer drum.**

## **To Install...**

1. Move dryer to an appropriate location for installation. Consider installing the dryer before the washer in side-by-side installations, to allow access to gas, electrical and exhaust connections. Lay two of the carton corner posts on the floor. Tip the dryer on its side so it will lay across both corner posts.
2. Set the dryer back in an upright position.
3. Review the Exhausting Section before installing the exhaust system. Install the ductwork from the dryer to the exhaust hood. The crimped end of the duct sections must point away from the dryer. DO NOT use sheet metal screws when assembling ducting. These joints should be taped. **Never use plastic flexible exhaust material.**

Tip for tight installations: install a section of exhaust system to the dryer before moving the dryer in place. Use duct tape to secure this section to the dryer but do not cover louvers in dryer cabinet.

## **4. Review Electrical Requirements Section.**

BEFORE OPERATING OR TESTING, follow the grounding instructions in the Grounding Section.

### **U.S. MODELS:**

**IMPORTANT** - All U.S. models are produced for a **3-WIRE SYSTEM CONNECTION**. The dryer frame is grounded to the neutral conductor at the terminal block.

A **4-WIRE SYSTEM CONNECTION** is required for new or remodeled construction, mobile homes, or if local codes do not permit grounding through neutral. If the 4-wire system is used, the dryer frame cannot be grounded to the neutral conductor at the terminal block. Refer to the following instructions for 3- and 4-WIRE SYSTEM CONNECTIONS.

Remove the terminal block cover plate.

Insert the power cord with a U.L. listed strain relief through the hole provided in the cabinet near the terminal block.

**NOTE: a strain relief must be used.**

Do not loosen the nuts already installed on the terminal block. Be sure they are tight. Use a 3/8" (1 cm) deep well socket.

## **5. Review Gas Requirements Section.**

Remove the pipe thread protective cap.

Apply pipe joint compound or about 1 1/2 wraps of Teflon tape over all threaded connections.

**NOTE:** Pipe joint compound must be resistant to the action of any liquefied petroleum gas.

Connect the gas supply to the dryer. An additional fitting is required to connect the 3/4" (1.9 cm) female thread end of a flexible connector to the 3/8" (1 cm) male threaded end on the dryer. Securely tighten the gas line fitting over threads.

Turn on the gas supply. Check all gas connections for leaks using a soap solution. If bubbles occur, tighten the connections and recheck. **DO NOT use an open flame to check for gas leaks.**

### 3-WIRE SYSTEM CONNECTIONS

1. Loosen or remove center terminal block screw.
2. Connect neutral wire (white or center wire) of power supply cord to the center, silver colored terminal screw of the terminal block. Tighten screw.
3. Connect the other wires to outer terminal block screws. Tighten screws.
4. Tighten strain relief screws.
5. Insert tab of terminal block cover into slot of dryer rear panel. Secure cover with hold-down screw.

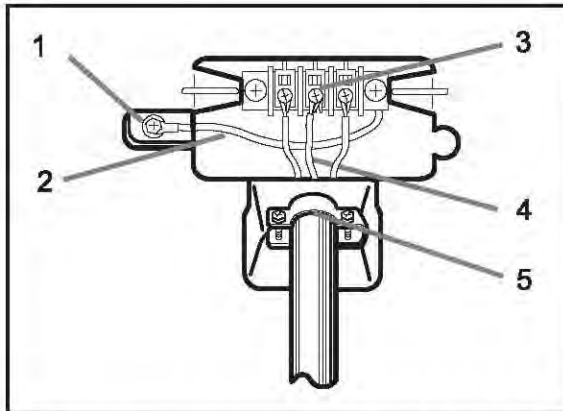

1. External ground connector
2. Neutral grounding wire (green/yellow)
3. Center silver-colored terminal block screw
4. Neutral wire (white or center wire)
5. 3/4 in. (1.9 cm) UL-listed strain relief

**WARNING:** If converting from a 4-wire electrical system to a 3-wire, the ground strap must be reconnected to the terminal block support to ground the dryer frame to the neutral conductor.

### 4-WIRE SYSTEM CONNECTIONS

1. Remove center terminal block screw.
2. Connect ground wire (green or bare) of power supply cord to external ground conductor screw.
3. Connect neutral wire (white or center wire) of power supply cord and appliance ground wire (green with yellow stripes) under central screw of the terminal block.
4. Connect the other wires to outer terminal block screws. Tighten screws.
5. Tighten strain relief screws.
6. Insert tab of terminal block cover into slot of dryer rear panel. Secure cover with hold-down screw.

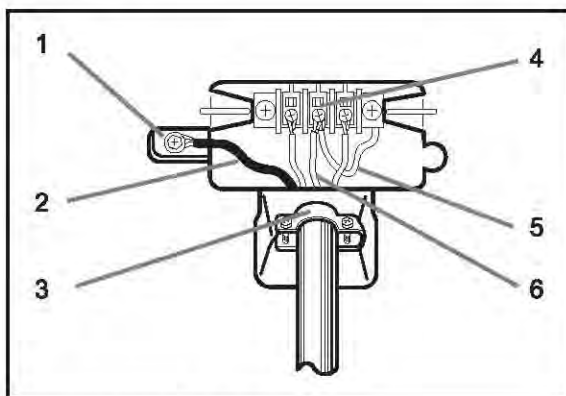

1. External ground connector
2. Green or bare copper wire of power supply cord
3. 3/4 in. (1.9 cm) UL-listed strain relief
4. Center silver-colored terminal block screw
5. Grounding wire (green/yellow)
6. Neutral wire (white or center wire)

### EXPORT MODELS

Refer to last page of installation instructions.

6. With a level, check the dryer, and make necessary adjustments to the leveling legs.
7. At this time, make sure all gas connections (on gas models), exhaust and electrical connections are complete. Plug dryer in, and check operation by using the check list below.
8. (GAS MODELS ONLY)

The burner may not ignite initially due to air in the gas line. Allowing the dryer to operate on a heat setting will purge the line. If the gas does not ignite within five minutes, turn the dryer off and wait

5 minutes. Be sure the gas supply to the dryer has been turned on. In order to confirm gas ignition, check the exhaust for heat.

### FINAL INSTALLATION CHECK LIST

- Dryer is plugged into electrical outlet and is properly grounded.
- Exhaust duct work is hooked up and joints taped.
- Plastic flexible duct is NOT used.
- Use rigid or stiff walled flexible metal vent material.
- Dryer is level with all legs firmly on the floor.
- Gas Models – gas is turned on, there are no gas leaks.
- Start dryer to confirm dryer runs, heats, shuts off.
- Demonstrate use to consumer.

### HOUSEHOLD INSTALLATION ACCESSORIES

- Vent hood – 4" (10.16 cm) opening – 059129
- Aluminum pipe – 4" x 24" (10.16 cm x 60.96 cm) – 059130
- Aluminum elbow – 4" (10.16 cm) – 059131
- Aluminum window plate – 15" x 20" (38.10 cm x 50.80 cm) – 4" (10.16 cm) hole – 059134
- Flexible aluminum vent duct – 4" (10.16 cm) diameter – 38" (81.28 cm) length stretches to 8' (2.44 cm) – 304353
- Clamp for flexible aluminum duct – 304630
- Exhaust duct kit for base or left side exhausting – 12001453
- Rectangular vent kit – 059144
- Dacron lint bag – 311353
- NATURAL to LP conversion kit – 306195
- LP to NATURAL conversion kit – 306204
- Anchor bracket kit – 303740
- Heating element conversion kit, 208V., not for Canada– 308590
- Grounding kit – 12001875
- Power cords – 240 v, 30 A
  - 4' (121.9 cm) – 3-wire – 33001780
  - 5' (152.4 cm) – 3-wire – 33001822
  - 6' (182.9 cm) – 3-wire – 33001823
  - 10' (304.8 cm) – 3-wire – 33001838
  - 4' (121.9 cm) – 4-wire – 33001781
  - 5' (152.4 cm) – 4-wire – 33001824
  - 6' (182.9 cm) – 4-wire – 33001825
  - 10' (304.8 cm) – 4-wire – 33001838



# ADDITIONAL INSTRUCTIONS FOR EXPORT MODELS

**(Not U.S. Mexico, or Canada)** Contact the distributor that sold the appliance or: Maytag International, 1475 East Woodfield Road Schaumburg, Illinois 60173 Phone: 847-273-3100, for information on product, shipping damage, replacement parts and accessories.

Maytag dryer models manufactured for operation on 60Hz AC are not designed for use on 50Hz AC electrical service and conversion of the product from 60 to 50Hz operation is not recommended. For additional information on 50Hz product, contact Maytag International. The electric service requirements can be found on the data label located on the front of the dryer behind the door.

## EXPORT ELECTRIC MODELS

Some export electric models are manufactured for operation on 230/240 volt, 50 Hz and some for operation on 220 Volt, 60 Hz electric service. A two-wire approved electrical service with a 30-amp fuse or circuit breaker is required. The dryer must be earthed with an earthing wire.

**IMPORTANT:** When permitted by local codes the dryer electrical supply may be connected by means of a power supply cord kit. The cord must be marked for use with clothes dryers, agency listed, rated for 240 volts - 30 amp minimum. The cord should be terminated with closed loop terminals, open-end spade lugs with turned up ends or with tinned leads. Do not reuse a power supply cord from an old dryer. The power cord or electric supply wiring must be retained at the dryer cabinet with a suitable agency listed strain relief.

## 2-WIRE SYSTEM CONNECTIONS

1. Loosen or remove center terminal block screw.
2. Connect neutral wire (White or center wire) of power supply cord to the center, silver colored terminal screw of the terminal block. Tighten screw.
3. Connect the other wire to outer terminal block screw. Tighten screw.
4. Tighten strain relief screws.
5. Insert tab of terminal block cover into slot of dryer rear panel, Secure cover with hold-down screw.

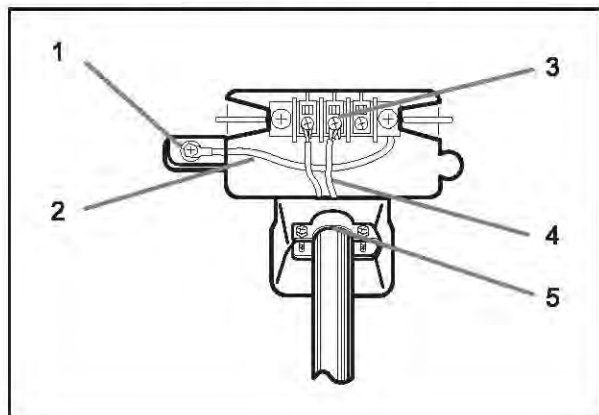

1. External ground connector
2. Neutral grounding wire (green.yellow)
3. Center silver-colored terminal clock screw.
4. Neutral wire (white or center wire)
5. 3/4 in. (1.9 c m ) UL-listed strain relief
6. Neutral wire (white or center wire)

**BEFORE OPERATING OR TESTING,** be sure the machine is properly grounded.

## EXPORT GAS MODELS

Some export gas models are manufactured for operation on 230/240 volt, 50 Hz and some for operation on 220 volt, 60 Hz electrical service with a 15 amp fuse or circuit breaker.

Export gas models have been manufactured for use with natural gas having a higher heating value of approximately 1025 BTU per cubic foot. Conversion to LP gas with a higher heating value must be performed by a qualified service technician. A 6 3722290 Natural Gas to LP Gas, 50 Hz conversion kit is available.

# **Appendix B**

# MAYTAG NEPTUNE® DRYER

# USE & CARE

## GUIDE

### TABLE OF CONTENTS

Safety Instructions .....	1-2
Dryer Exhaust Tips .....	3
Operating Instructions.....	4-5
Using the Controls.....	6-8
Special Laundry Tips.....	9
Care and Cleaning.....	10
Replace Drum Light.....	10
Reverse the Door .....	10
Drying Rack .....	11
Troubleshooting .....	12-13
Warranty.....	15
Guide d'utilisation et d'entretien.....	16
Guía de Uso y Cuidado.....	32

## IMPORTANT SAFETY INSTRUCTIONS

### WELCOME

Welcome and congratulations on your purchase of a Maytag Neptune® dryer! Your complete satisfaction is very important to us. For best results, we suggest reading this material to help acquaint you with proper operating and maintenance procedures.

Should you need assistance in the future, it is helpful to:

- 1) Have complete model and serial number identification of your dryer.

Date of Purchase \_\_\_\_\_

Model Number \_\_\_\_\_

Serial Number \_\_\_\_\_

- 2) **IMPORTANT: Keep this guide and the sales receipt in a safe place for future reference. Proof of original purchase date is needed for warranty service.**

If you have questions, call:

Maytag Customer Assistance  
1-800-688-9900 USA  
1-800-688-2002 CANADA  
1-800-688-2080 USA TTY  
(for deaf, hearing impaired or speech impaired)  
(Mon.–Fri., 8am–8pm Eastern Time)  
<http://www.maytag.com>

**For service and warranty information, see page 15.**

**NOTE: In our continuing effort to improve the quality of our appliances, it may be necessary to make changes to the appliance without revising this guide.**

## What You Need to Know About Safety Instructions

Warning and Important Safety Instructions appearing in this manual are not meant to cover all possible conditions and situations that may occur. Common sense, caution and care must be exercised when installing, maintaining or operating appliance.

Always contact your manufacturer about problems or conditions you do not understand.

### Recognize Safety Symbols, Words, Labels

#### **WARNING**

**WARNING:** Hazards or unsafe practices which **COULD** result in severe personal injury or death.

#### **CAUTION**

**CAUTION:** Hazards or unsafe practices which **COULD** result in minor personal injury.

#### **WARNING**

**WARNING:** For your safety, the information in this manual must be followed to minimize the risk of fire or explosion or to prevent property damage, personal injury or death.

- Do not store or use gasoline or other flammable vapors and liquids in the vicinity of this or any other appliance.

#### **WHAT TO DO IF YOU SMELL GAS:**

- Do not try to light any appliance.
- Do not touch any electrical switch.
- Do not use any phone in your building.
- Clear the room, building or area of all occupants.
- Immediately call your gas supplier from a neighbor's phone. Follow the gas supplier's instructions.
- If you cannot reach your gas supplier, call the fire department.

Installation and service must be performed by a qualified installer, service agency or the gas supplier.

## Save These Instructions

## IMPORTANT SAFETY INSTRUCTIONS

### WELCOME

Welcome and congratulations on your purchase of a Maytag Neptune® dryer! Your complete satisfaction is very important to us. For best results, we suggest reading this material to help acquaint you with proper operating and maintenance procedures.

Should you need assistance in the future, it is helpful to:

- 1) Have complete model and serial number identification of your dryer.

Date of Purchase \_\_\_\_\_

Model Number \_\_\_\_\_

Serial Number \_\_\_\_\_

- 2) **IMPORTANT: Keep this guide and the sales receipt in a safe place for future reference. Proof of original purchase date is needed for warranty service.**

If you have questions, call:

Maytag Customer Assistance  
1-800-688-9900 USA  
1-800-688-2002 CANADA  
1-800-688-2080 USA TTY  
(for deaf, hearing impaired or speech impaired)  
(Mon.–Fri., 8am–8pm Eastern Time)  
<http://www.maytag.com>

**For service and warranty information, see page 15.**

**NOTE: In our continuing effort to improve the quality of our appliances, it may be necessary to make changes to the appliance without revising this guide.**

## What You Need to Know About Safety Instructions

Warning and Important Safety Instructions appearing in this manual are not meant to cover all possible conditions and situations that may occur. Common sense, caution and care must be exercised when installing, maintaining or operating appliance.

Always contact your manufacturer about problems or conditions you do not understand.

### Recognize Safety Symbols, Words, Labels

#### **WARNING**

**WARNING:** Hazards or unsafe practices which **COULD** result in severe personal injury or death.

#### **CAUTION**

**CAUTION:** Hazards or unsafe practices which **COULD** result in minor personal injury.

#### **WARNING**

**WARNING:** For your safety, the information in this manual must be followed to minimize the risk of fire or explosion or to prevent property damage, personal injury or death.

- Do not store or use gasoline or other flammable vapors and liquids in the vicinity of this or any other appliance.

#### **WHAT TO DO IF YOU SMELL GAS:**

- Do not try to light any appliance.
- Do not touch any electrical switch.
- Do not use any phone in your building.
- Clear the room, building or area of all occupants.
- Immediately call your gas supplier from a neighbor's phone. Follow the gas supplier's instructions.
- If you cannot reach your gas supplier, call the fire department.

Installation and service must be performed by a qualified installer, service agency or the gas supplier.

## Save These Instructions

## DRYER EXHAUST TIPS

### ⚠ WARNING

⚠ **WARNING:** Plastic or nonmetal flexible duct presents a potential fire hazard.

### Do

**Read the installation instructions and the Use and Care Guide.**

### Do

Let your dryer exhaust the air easily.

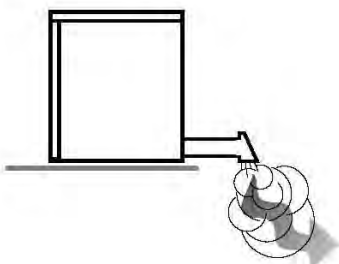

### Do

Use 4 inch diameter rigid metal duct. Tape all joints, including at the dryer. Never use lint-trapping screws.

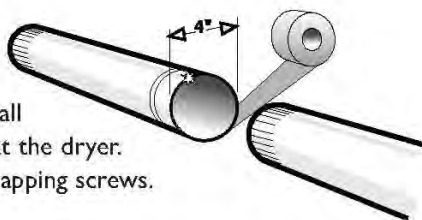

### Do

Keep duct runs as straight as possible.

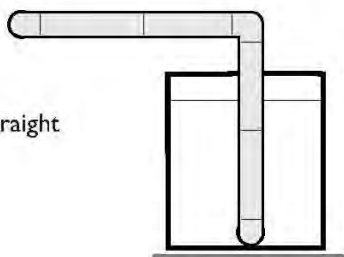

### Do

Clean all old ducts before installing your new dryer. Be sure vent flap opens and closes freely. Inspect and clean the exhaust system annually.

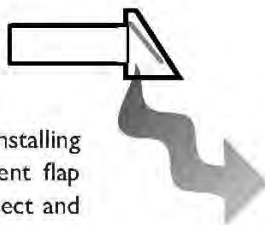

### DON'T

**Let a poor exhaust system cause slow drying.**

### DON'T

Restrict your dryer with a poor exhaust system.

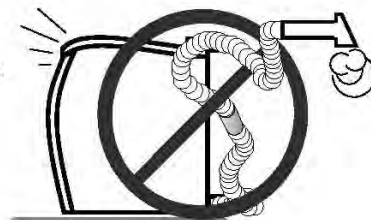

### DON'T

Use plastic, thin foil, or non-metal flexible duct.



### DON'T

Use longer than necessary duct runs with many elbows.

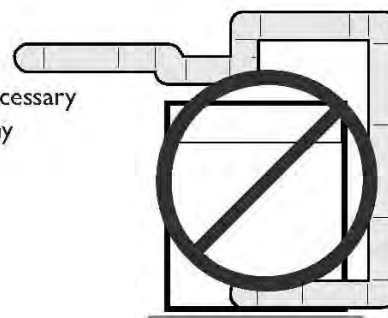

### DON'T

Allow crushed or clogged ducts and vent.

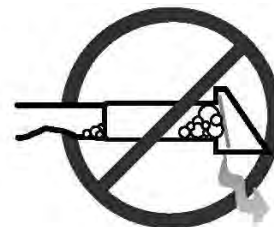

## DRYER EXHAUST TIPS

### ⚠ WARNING

⚠ **WARNING:** Plastic or nonmetal flexible duct presents a potential fire hazard.

#### Do

Read the installation instructions and the Use and Care Guide.

#### DON'T

Let a poor exhaust system cause slow drying.

#### Do

Let your dryer exhaust the air easily.

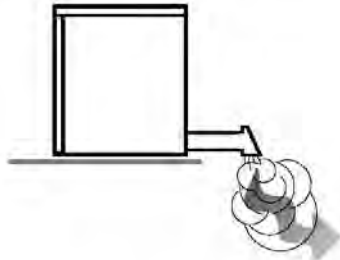

#### DON'T

Restrict your dryer with a poor exhaust system.



#### Do

Use 4 inch diameter rigid metal duct. Tape all joints, including at the dryer. Never use lint-trapping screws.

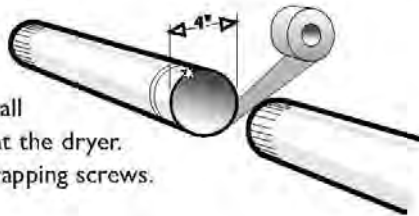

#### DON'T

Use plastic, thin foil, or non-metal flexible duct.



#### Do

Keep duct runs as straight as possible.

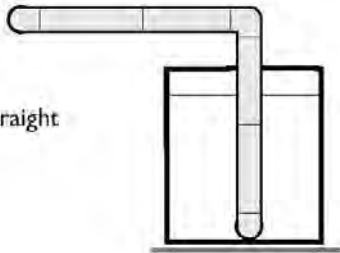

#### DON'T

Use longer than necessary duct runs with many elbows.

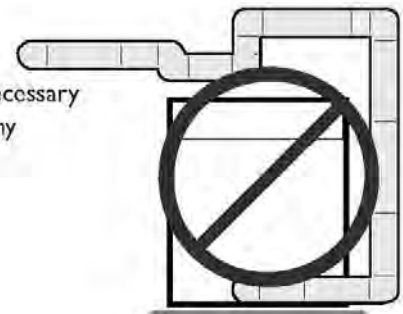

#### Do

Clean all old ducts before installing your new dryer. Be sure vent flap opens and closes freely. Inspect and clean the exhaust system annually.

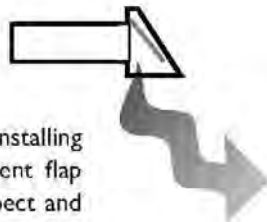

#### DON'T

Allow crushed or clogged ducts and vent.



## OPERATING INSTRUCTIONS

### START THE DRYER

After setting the cycle and desired options, press the **Cycle Selector** dial to start the dryer. To pause the cycle, press **Cycle Selector** dial again. To restart the cycle, press **Cycle Selector** dial and the cycle will resume from the point of interruption.

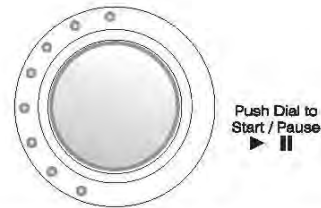

### TURN THE DRYER OFF

#### Power Off

Press the **Power Off** pad to cancel the cycle and stop the dryer.



### ESTIMATED TIME DISPLAY (SELECT MODELS)

The display window shows the estimated time remaining in the cycle after the **Cycle Selector** dial is pressed. The estimated time remaining may fluctuate as the cycle progresses.



### CYCLE STATUS LIGHTS (STYLE VARIES BY MODEL)

The Drying light will illuminate and remain lit until the cycle is complete. When the dryer is in the cool-down portion of the cycle, the Cooling light will illuminate.

If the Wrinkle Prevent option has been selected, the Wrinkle Prevent light will illuminate. Chasing lights will appear in the display when Wrinkle Prevent is selected (select models). See page 8.

When the cycle is complete, "END" or "00" (select models) will appear in the display until the dryer door is opened.

If the dryer is paused during a cycle, the indicator lights will blink until the **Cycle Selector** dial is pressed.





## USING THE CONTROLS

Control features vary by model.

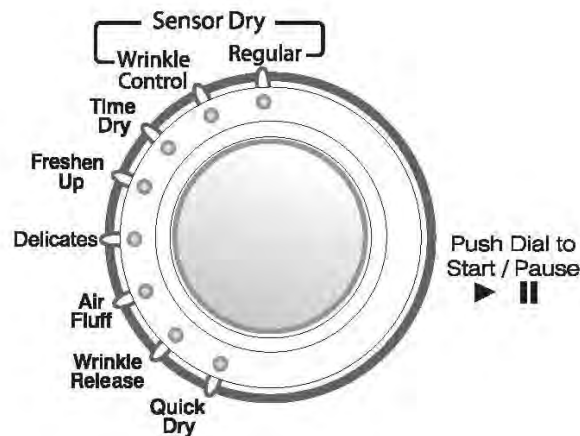

### Step 1

#### SELECT CYCLE

To select a cycle, rotate the **Cycle Selector** dial to the desired cycle. The indicator light by the cycle name will illuminate.

The Regular and Wrinkle Control cycles are Sensor Dry cycles. Sensor Dry automatically senses the moisture in the load and shuts the dryer off when the selected dryness level (very dry to damp dry) is reached.

#### Regular

The Regular cycle is designed to dry loads such as towels, underwear, jeans, etc.

#### Wrinkle Control

The Wrinkle Control cycle is designed to dry wrinkle-free cottons, synthetic fabrics, knits and permanent press fabrics automatically. The cycle minimizes wrinkling by providing a longer unheated cool-down period at the end of the cycle.

#### Time Dry

Time Dry allows you to select the desired cycle time in minutes. Turn the **Cycle Selector** dial to Time Dry, then press the **Time** up arrow to set the drying time. Press the arrow repeatedly to scroll through the time settings. To add or subtract time from the cycle, see Options-Adjust Time, page 8.



#### Freshen Up (select models)

A short dry cycle designed to remove odors and freshen garments.

#### Delicates

The Delicates cycle is designed to dry heat-sensitive items at the low drying temperature.

#### Air Fluff

The Air Fluff cycle tumbles the load in room temperature air.

#### Wrinkle Release

The Wrinkle Release cycle will release wrinkles from items that are clean and dry but only slightly wrinkled, such as from a crowded closet or suitcase or from sitting in the dryer too long after the cycle has ended. Wrinkle Release can be used with any temperature selection.

#### Quick Dry (select models)

Provides a 30 minute dry cycle.

## USING THE CONTROLS

### Step 2

#### SELECT DRYNESS LEVEL

To select the dryness level in the Regular or Wrinkle Control Sensor Dry cycles, press the **Sensor Dry Level** pad. An indicator light will illuminate next to the desired dryness level. Press the pad repeatedly to scroll through the settings.

Loads of larger or bulkier size may require the Very Dry (select models) or More Dry setting to completely dry the load. The Less Dry setting is best suited for lightweight fabrics or for leaving some moisture in the clothing at the end of the cycle. Damp Dry (select models) is designed to partially dry items. Use for items that lay flat or hang to dry.

- Very Dry
- More Dry
- Normal Dry
- Less Dry
- Damp Dry



Sensor Dry Level

### Step 3

#### SELECT TEMPERATURE

To select the correct temperature for the load, press the **Temperature** pad. An indicator light will illuminate next to the desired temperature. Press the pad repeatedly to scroll through the settings.

Use the chart below as a guide:

DRYER TEMPS	LOAD TYPE
<b>Regular</b>	For sturdy cottons or those labeled Tumble Dry.
<b>Medium</b>	For permanent press, synthetics, lightweight cottons or items labeled Tumble Dry Medium.
<b>Low</b>	For heat sensitive items labeled Tumble Dry Low or Tumble Dry Warm.
<b>Extra Low (select models)</b>	Provides the lowest heated dry temperature possible.

- Regular
- Medium
- Low
- Extra Low



Temperature

# USING THE CONTROLS

## Step 4

### SELECT OPTIONS (IF DESIRED)

#### Adjust Time

Time can be added or subtracted from the automatically set times in the Time Dry, Freshen Up (select models), Delicates, Air Fluff, Wrinkle Release or Quick Dry (select models) cycles.

To add or subtract time from the cycle, press the **Adjust Time** up or down arrow pad until the desired time is displayed.



#### End of Cycle Chime

When the cycle is complete, an audible chime will sound. When the Wrinkle Prevent option is selected, the chime will sound intermittently. Adjust the volume of the chime or turn it off by pressing the **Chime** pad. Press the pad repeatedly to scroll through the choices.

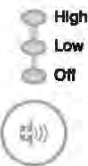

Chime

#### Wrinkle Prevent

Wrinkle Prevent provides approximately 95 minutes of intermittent tumbling in unheated air at the end of the cycle to reduce wrinkling. Press the **Wrinkle Prevent** pad to activate this feature. The indicator light above the pad will illuminate when Wrinkle Prevent is selected. Chasing lights appear in the display when the Wrinkle Prevent option is selected (select models). The load is dry and can be removed at any time during the Wrinkle Prevent cycle.



#### Control Lock

The control panel can be locked for safety, cleaning or to prevent unwanted use. The panel will not function when locked.

To lock the controls, press and hold the **Sensor Dry Level** and **Temperature** pads for 3 seconds. The Control Lock indicator light will illuminate.

To unlock the controls, press and hold the **Sensor Dry Level** and **Temperature** pads for 3 seconds. The Control Lock indicator light will go out.

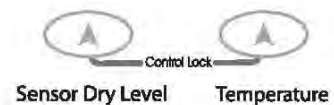

## Step 5

### START THE DRYER

Press the **Cycle Selector** dial to start the dryer. The dryer door must be closed for the dryer to operate. If the door is opened during the cycle, the **Cycle Selector** dial must be pushed again to resume the cycle once the door is closed.

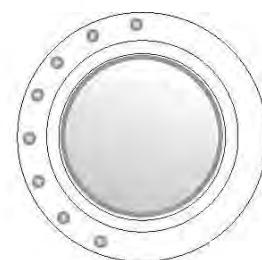

Push Dial to Start / Pause

## SPECIAL LAUNDRY TIPS

Please follow the care label or manufacturer's instructions for drying special items. If care label instructions are not available, use the following information as a guide.

<p><b>Bedspreads &amp; Comforters</b></p>	<ul style="list-style-type: none"> <li>• Follow the care label instructions or dry on the Sensor Dry Regular cycle and Regular temperature.</li> <li>• Be sure the item is thoroughly dry before using or storing.</li> <li>• May require repositioning to ensure even drying.</li> </ul>
<p><b>Blankets</b></p>	<ul style="list-style-type: none"> <li>• Use Sensor Dry Regular and dry only one blanket at a time for best tumbling action.</li> <li>• Be sure the item is thoroughly dry before using or storing.</li> </ul>
<p><b>Curtains &amp; Draperies</b></p>	<ul style="list-style-type: none"> <li>• Use the Sensor Dry Wrinkle Control cycle and Low or Extra Low temperature to help minimize wrinkling.</li> <li>• Dry these in small loads for best results and remove as soon as possible.</li> </ul>
<p><b>Cloth Diapers</b></p>	<ul style="list-style-type: none"> <li>• Use the Sensor Dry Regular cycle and the Regular temperature setting for soft, fluffy diapers.</li> </ul>
<p><b>Down-filled Items (jackets, sleeping bags, comforters, etc.)</b></p>	<ul style="list-style-type: none"> <li>• Use the Sensor Dry Regular cycle and the Low or Extra Low temperature setting.</li> <li>• Place a clean pair of sneakers in the dryer with the item to fluff the down comforters, etc. Adding a couple of dry towels shortens dry time and absorbs moisture.</li> </ul>
<p><b>Foam Rubber (rug backs, stuffed toys, shoulder pads, etc.)</b></p>	<ul style="list-style-type: none"> <li>• DO NOT dry on a heat setting. Use the Air Fluff cycle (no heat).</li> <li>•  <b>WARNING</b> – Drying a rubber item with heat may damage it or be a fire hazard.</li> </ul>
<p><b>Pillows</b></p>	<ul style="list-style-type: none"> <li>• Use the Sensor Dry Regular cycle.</li> <li>• Add a couple of dry towels and a pair of clean sneakers to help the tumbling action and to fluff the item.</li> <li>• DO NOT dryer-dry kapok or foam pillows.</li> </ul>
<p><b>Plastics (shower curtains, outdoor furniture covers, etc.)</b></p>	<ul style="list-style-type: none"> <li>• Use the Air Fluff cycle or the Time Dry cycle and the Low or Extra Low temperature setting depending on the care label instructions.</li> </ul>

### AVOID DRYER DRYING

- Fiberglass items (curtains, draperies, etc.)
- Woolens, unless recommended on the label.
- Vegetable or cooking oil soaked items (see pg. 2).

## CARE AND CLEANING

**Control Panel** – Clean with a soft, damp cloth. Do not use abrasive substances. Do not spray cleaners directly on the panel.

The control panel finish could be damaged by some laundry pre-treatment soil and stain-remover products. Apply such products away from the dryer and wipe up any spills or overspray immediately.

**Tumbler** – Remove any stains such as crayon, ink pen or fabric dye (from new items such as towels or jeans) with an all-purpose cleaner. Then tumble old towels or rags to remove any excess stain or cleaning substance. Once these steps are done, stains may still be visible, but should not transfer to subsequent loads.

**Stainless Steel Tumbler (select models)** – To clean the stainless steel tumbler, use a damp cloth with a mild, non-abrasive cleaner suitable for stainless steel surfaces. Remove the cleaner residue and then dry with a clean cloth.

**Dryer Exterior** – Clean with a soft, damp cloth. **Do not** use abrasive substances. Protect the surface from sharp objects.

**Dryer Exhaust System** – Should be inspected and cleaned once a year to maintain optimum performance. The outside exhaust hood should be cleaned more frequently to ensure proper operation. (Refer to the Installation Instructions for more information.)

## REPLACE DRUM LIGHT

### Instructions for replacing the bulb:

- 1) Unplug or disconnect the dryer from the electrical power supply.
- 2) Open the door and use a screwdriver to remove the screw attaching the light cover.
- 3) Remove light cover.
- 4) Rotate bulb counter-clockwise to remove from socket.
- 5) Replace the bulb with a 120 volt, 10 watt, E12 type light bulb.
- 6) Turn the light bulb clockwise into socket.
- 7) Replace light cover.
- 8) Reinstall the screw into the light cover screw hole.
- 9) Reconnect dryer to power supply.

## REVERSE THE DOOR

### Instructions for reversing the dryer door:

- 1) Remove 2 hinge screws holding door hinge in place.
- 2) Remove the door and lay carefully aside.
- 3) Remove 2 hinge screws on the opposite side of door hinge.
- 4) Remove 2 screws on the door catch plate.
- 5) Move door catch plate to opposite side and attach with screws.
- 6) Move the door to the opposite side and replace 2 hinge screws.
- 7) Replace 2 hinge screws in opposite holes.

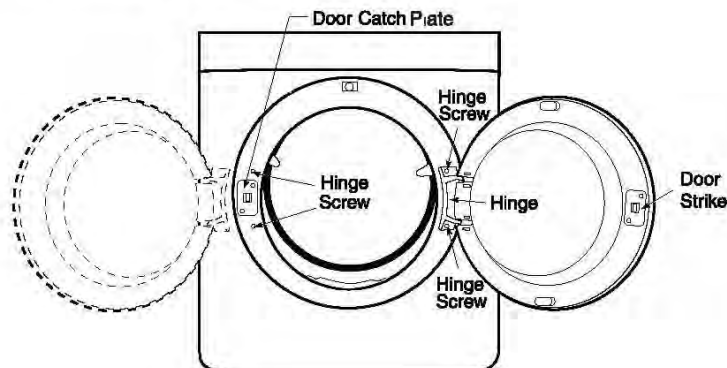

## DRYING RACK (SELECT MODELS)

### INSTALLING THE DRYING RACK

- 1) Open dryer door.
- 2) Position drying rack in tumbler placing the two rear legs in the two recessed areas in the back wall of the dryer.
- 3) Place the front lip of the drying rack on top of the lint filter.
- 4) Place items to be dried on the rack, leaving space between them so air can reach all the surfaces.
- 5) Close the dryer door.
- 6) Use the Time Dry cycle. Select time according to moisture and weight of item. Start the dryer. It may be necessary to reset the timer if a longer drying time is needed.

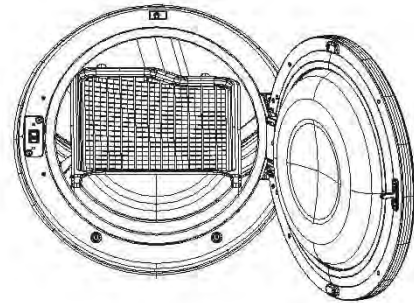
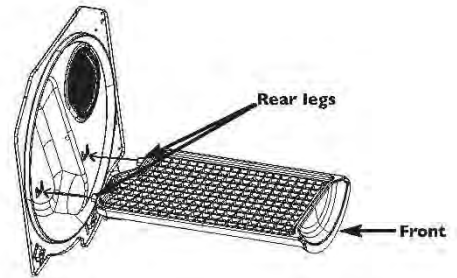

#### SUGGESTED ITEMS                      SUGGESTED TEMP. SETTINGS

Washable sweaters (block to shape and lay flat on rack)	Heat
Stuffed toys (cotton or polyester fiber filled)	Heat
Stuffed toys (foam or rubber filled)	Air Fluff
Foam rubber pillows	Air Fluff
Sneakers	Air Fluff or Heat

#### **⚠ WARNING**

Drying foam rubber, plastic or rubber on a heat setting may cause damage to the item and could lead to a fire hazard.

# TROUBLESHOOTING

## INFORMATION CODES

Information codes may be displayed to help you better understand what is occurring with the dryer.

<b>Code Symbol</b>	<b>Meaning</b>	<b>Solution</b>
<b>T5</b>	Heater temperature control problem.	Call for service, see below.
<b>dC</b>	Door open sensing problem.	Call for service, see below.
<b>do</b>	Door Open Error When the door is opened, the dryer will not operate.	Be sure the door is latched shut. If problem continues, call for service, see below.

For any codes not listed above, call Maytag Customer Service at 1-800-688-9900 USA or 1-800-688-2002 Canada.

## TROUBLESHOOTING

### CHECK THESE POINTS IF YOUR MAYTAG NEPTUNE® DRYER...

<b>Doesn't Run</b>	<ul style="list-style-type: none"> <li>• Be sure the door is latched shut.</li> <li>• Be sure the power cord is plugged into a live electrical outlet.</li> <li>• Check the home's circuit breaker and fuses.</li> <li>• Press the <b>Cycle Selector</b> dial again if the door is opened during the cycle.</li> </ul>
<b>Doesn't Heat</b>	<ul style="list-style-type: none"> <li>• Check the home's circuit breaker and fuses.</li> <li>• Select a heat setting, not Air Fluff.</li> <li>• On a gas dryer, check that the gas supply is on.</li> <li>• Clean the lint filter and exhaust duct.</li> <li>• Dryer may have moved into the cool-down portion of the cycle.</li> </ul>
<b>Doesn't Dry</b>	<ul style="list-style-type: none"> <li>• Check all of the above, plus...</li> <li>• Be sure the exhaust hood at the outside of the home can open and close freely.</li> <li>• Check exhaust system for lint build-up. Ducting should be inspected and cleaned annually.</li> <li>• Use 4" rigid metal exhaust duct.</li> <li>• Do not overload. 1 Wash load = 1 Dryer load.</li> <li>• Sort heavy items from lightweight items.</li> <li>• Large, bulky items like blankets or comforters may require repositioning to ensure even drying.</li> <li>• Check that the washer is draining properly to extract adequate water from the load.</li> <li>• Clothes load is too small to tumble properly. Add a few towels.</li> </ul>
<b>Is Noisy</b>	<ul style="list-style-type: none"> <li>• Check the load for objects such as coins, loose buttons, nails, etc. Remove promptly.</li> <li>• It is normal to hear the dryer gas valve or heating element cycle on and off during the drying cycle.</li> <li>• Be sure the dryer is leveled properly as outlined in the installation manual.</li> <li>• It is normal for the dryer to hum due to the high velocity of air moving through the dryer drum and exhaust system.</li> </ul>
<b>Dries Unevenly</b>	<ul style="list-style-type: none"> <li>• Seams, pockets and other similar heavy areas may not be completely dry when the rest of the load has reached the selected dryness level. This is normal. Select the <b>Very Dry</b> setting if desired.</li> <li>• If one heavy item is dried with a lightweight load, such as one towel with sheets, it is possible that the heavy item will not be completely dry when the rest of the load has reached the selected dryness level. Sort heavy items from lightweight items for best drying results.</li> </ul>
<b>Has an Odor</b>	<ul style="list-style-type: none"> <li>• Household odors such as from painting, varnishing, strong cleaners, etc. may enter the dryer with the surrounding room air. This is normal as the dryer draws the air from the room, heats it, pulls it through the tumbler and exhausts it to the outside. When these odors are present in the air, ventilate the room completely before using the dryer.</li> </ul>
<b>Dryer shuts off before load is dry</b>	<ul style="list-style-type: none"> <li>• Clothes load is too small. Add more similar items or a few towels and restart the cycle.</li> <li>• Clothes load is too large. Remove some of the load and restart the dryer.</li> </ul>

For further assistance contact Maytag Services<sup>SM</sup>, Maytag Customer Assistance: 1-800-688-9900 U.S.A. or 1-800-688-2002 Canada. U.S.A. Customers using TTY for deaf, hearing impaired or speech impaired, call 1-800-688-2080.



NOTES

# CLOTHES DRYER WARRANTY

## Neptune® Dryer Warranty

### Full One-Year Warranty

For one (1) year from the date of original retail purchase, any part which fails in normal home use will be repaired or replaced free of charge.

### Limited Warranty

After the first year from date of original retail purchase, through the time periods listed below, the parts designated below which fail in normal home use will be repaired or replaced free of charge for the part itself, with the owner paying all other costs, including labor, mileage, transportation, trip charge and diagnostic charge, if required.

**Second Year** – All parts.

### Additional Limited Warranty Against Rust-Through

Should an exterior cabinet, including the top and door, rust through during the one year period starting from the date of retail purchase, repair or replacement will be made free of charge. After the first and through the fifth year, repair or replacement will be made free of charge for the part itself, with the owner paying all other costs, including labor, mileage, transportation, trip charge and diagnostic charge, if required.

**Please Note:** This full warranty and the limited warranty apply when the dryer is located in the United States or Canada. Dryers located elsewhere are covered by the limited warranty only, including parts which fail during the first two years.

### Canadian Residents

This warranty covers only those appliances installed in Canada that have been listed with the Canadian Standards Association unless the appliances are brought into Canada due to transfer of residence from the United States to Canada.

The specific warranties expressed above are the **ONLY** warranties provided by the manufacturer. This warranty gives you specific legal rights, and you may also have other rights that vary from state to state.

## What is Not Covered By These Warranties:

1. Conditions and damages resulting from any of the following:
  - a. Improper installation, delivery or maintenance.
  - b. Any repair, modification, alteration, or adjustment not authorized by the manufacturer or an authorized servicer.
  - c. Misuse, abuse, accidents or unreasonable use.
  - d. Incorrect electric current, voltage or supply.
  - e. Improper setting of any control.
2. Warranties are void if the original serial numbers have been removed, altered or cannot be readily determined.
3. Light bulbs.
4. Products purchased for commercial or industrial use.
5. The cost of service or service call to:
  - a. Correct installation errors.
  - b. Instruct the user on the proper use of the product.
  - c. Transport the appliance to the servicer.
6. Consequential or incidental damages sustained by any person as a result of any breach of these warranties.  
Some states do not allow the exclusion or limitation of consequential or incidental damages, so the above exclusion may not apply.

## To Obtain Warranty Service

To locate an authorized service company in your area, contact the dealer from whom your appliance was purchased; or call Maytag Services<sup>SM</sup>, Maytag Customer Assistance. Should you not receive satisfactory warranty service, please call or write:

Maytag Services<sup>SM</sup>  
Attn: CAIR® Center  
P.O. Box 2370

Cleveland, TN 37320-2370

**U.S.A. 1-800-688-9900**

**Canada 1-800-688-2002**

**U.S.A. Customers using TTY for deaf, hearing impaired or speech impaired, call 1-800-688-2080.**

## NOTE:

When contacting Maytag Services<sup>SM</sup>, Maytag Customer Assistance about a service problem, please include the following:

- a. Your name, address and telephone number;
- b. Model number and serial number of your appliance;
- c. Name and address of your dealer and the date the appliance was purchased;
- d. A clear description of the problem you are having;
- e. Proof of purchase.

Use & Care Guides, service manuals and parts information are available from Maytag Services<sup>SM</sup>, Maytag Customer Assistance.

**Maytag • 403 West Fourth Street North • P. O. Box 39 • Newton, Iowa 50208**