



Service

This manual is to be used by qualified appliance technicians only. Maytag does not assume any responsibility for property damage or personal injury for improper service procedures done by an unqualified person.

2001-2003 Countertop Domestic Microwave Ovens

This Base Manual covers general information
This manual includes, but is
not limited to the following:

ACM0720AB
ACM0720AW
ACM0860AB
ACM0860AC
ACM0860AS
ACM0860AW
ACM1120AB
ACM1120AS
ACM1120AW
ACM1420AB
ACM1420AW
ACM1460AB
ACM1460AC
ACM1460AW
ACM2160AB
ACM2160AC
ACM2160AS
ACM2160AW
MMC5086AAB
MMC5086AAQ
MMC5086AAS
MMC5086AAW
UMC1061AAB
UMC1061AAW



©2005 Maytag Services

16026268
Replaces 16021670
June 2005

Important Information

Pride and workmanship go into every product to provide our customers with quality products. It is possible, however, that during its lifetime a product may require service. Products should be serviced only by a qualified service technician who is familiar with the safety procedures required in the repair and who is equipped with the proper tools, parts, testing instruments and the appropriate service manual. **REVIEW ALL SERVICE INFORMATION IN THE APPROPRIATE SERVICE MANUAL BEFORE BEGINNING REPAIRS.**

Important Notices for Consumers and Servicers



WARNING

To avoid risk of serious injury or death, repairs should not be attempted by an unauthorized person, dangerous conditions (such as exposure to electrical shock) may result.



CAUTION

Maytag will not be responsible for any injury or property damage from improper service procedures. If performing service on your own product, assume responsibility for any personal injury or property damage which may result.

To locate an authorized servicer, please consult your telephone book or the dealer from whom you purchased this product. For further assistance, please contact:

Customer Service Support Center

CAIR Center

<u>Web Site</u>	<u>Telephone Number</u>
WWW.AMANA.COM	1-800-843-0304
WWW.JENNAIR.COM	1-800-536-6247
WWW.MAYTAG.COM	1-800-688-9900
CAIR Center in Canada	1-800-688-2002
Amana Canada Product	1-866-587-2002

Recognize Safety Symbols, Words, and Labels



DANGER

DANGER—Immediate hazards which **WILL** result in severe personal injury or death.



WARNING

WARNING—Hazards or unsafe practices which **COULD** result in severe personal injury or death.



CAUTION

CAUTION—Hazards or unsafe practices which **COULD** result in minor personal injury or product or property damage.

Table of Contents

Important Information	2	Disassembly Procedures	
Important Product Information	4	Door Assembly	22
Important Safety Information	5	Door Disassembly	22
Microwave Leakage Testing	6	Outer Case	23
Specification Information	7	Control Panel	23
General Information		P.C. Board	23
Placement of the Oven	9	Control Key Panel	24
Location of Model Number	9	Interlock Door Latch Switches	24
Model Identification	9	High Voltage Capacitor	25
Service	9	Diode	25
Parts and Accessories	9	Transformer	26
Extended Service Plan	9	Fuse	26
Radio Interference	9	Magnetron	26
Electrical Requirements	10	Suction Guide / Fan Motor Assembly	26
Cleaning	10	Humidity Sensor–ACM1460A* and ACM2160A*	27
Grounding Instructions	10	Oven Thermostat	27
Microwave Oven Description	11	Light Socket	27
Testing Procedures		Turntable Motor	27
Primary Interlock Switch Test	12	Noise Filter	27
Secondary Interlock Switch Test	12	Wiring Diagrams And Schematics	28
Interlock Monitor Switch Test	12	Appendix A	
Magnetron	12	Installation Instructions	A-2
High Voltage Diode	13	Appendix B	
High Voltage Transformer	13	Programming Instructions for	
Fan Motor	13	ACM0720A* and ACM1061A*	B-2
Turntable Motor	13	Programming Instructions for	
High Voltage Capacitor	13	ACM1120A* and ACM1420A*	B-4
Humidity Sensor	13	Programming Instructions for	
Relay	14	ACM1460A* and ACM2160A*	B-7
Oven Thermostat	14	Programming Instructions for	
Fuse	14	ACM0860A* and MMC5086A*	B-10
Control Key Panel	15	Appendix C	
Troubleshooting Procedures	16	Cleaning Instructions	C-2

Important Product Information

WARNING

Precautions to be observed before and during servicing to avoid possible exposure to excessive microwave energy, or electrical shock disconnect power to oven.

- (A) Do not operate or allow oven to be operated with door open.
- (B) Make the following safety checks on all ovens to be serviced before activating the magnetron or other microwave source, and make repairs as necessary:
 - Interlock operation
 - Proper door closing
 - Seal and sealing surfaces (arcing, wear, and other damage)
 - Damage to or loosening of hinges and latches
 - Evidence of dropping or abuse
- (C) Before turning on microwave power for any service test or inspection within the microwave generating compartments, check the magnetron, waveguide or transmission line, and cavity for proper alignment, integrity, and connections.
- (D) Any failed or misadjusted components in the interlock, monitor, door seal, and microwave generation and transmission systems shall be repaired, replaced or adjusted by procedures described in this manual before oven is released to the consumer.
- (E) Check microwave leakage to verify compliance with the federal performance standard should be performed on each oven prior to release to the consumer.

Wiring

Good service practice is to never route wiring over terminals and/or sharp edges. This applies to any wiring without regard to the circuit voltage. Wire insulation material and thickness is designed and regulated for electrical spacing purpose only, but cannot always be relied upon because of possible cuts and/or abrasions, which can occur during servicing.

WARNING

To avoid risk of electrical shock, injury, or death, make sure these grounding instructions are followed.

Grounding Instructions

WARNING

Do not remove grounding prong when installing grounded appliance in a home or business that does not have three wire grounding receptacle, under no condition is grounding prong to be cut off or removed. It is the personal responsibility of the consumer to contact a qualified electrician and have properly grounded three prong wall receptacle installed in accordance with appropriate electrical codes

Should a two prong adapter plug be required temporarily, it is the personal responsibility of the consumer to have it replaced with properly grounded three prong receptacle or the two prong adapter properly grounded by a qualified electrician in accordance with appropriate electrical codes.

Servicing of Grounded Products

The standard accepted color coding for grounding wires is GREEN or GREEN WITH YELLOW STRIPE. These ground leads are NOT to be used as current carrying conductors. It is extremely important that the technician replace any and all grounds prior to completion of the service call. Under no condition should ground wire be left off causing a potential hazard to technicians and consumer.

Important Safety Information



CAUTION

Read the following information to avoid possible exposure to microwave radiation:

The basic design of the Maytag and Amana microwave oven makes it an inherently safe device to both use and service. However, there are some precautions which should be followed when servicing the microwave oven to maintain this safety. These are as follows:

1. Always operate the unit from an adequately grounded outlet. Do not operate on a two-wire extension cord.
2. Before servicing the unit (if unit is operable), perform the microwave leakage test.
3. The oven should never be operated if the door does not fit properly against the seal, the hinges or hinge bearings are damaged or broken; the choke is damaged, (pieces missing, etc.); or any other visible damage can be noted. Check the choke area to ensure that this area is clean and free of all foreign matter.
4. If the oven operates with the door open and produces microwave energy, take the following steps.
 - A. Tell the user not to operate the oven.
 - B. Contact Maytag immediately.
5. Always have the oven disconnected when the outer case is removed except when making the "live" tests called for in the Service Manual. Do not reach into the equipment area while the unit is energized. Make all connections for the test and check them for tightness before plugging the cord into the outlet.
6. Always ground the capacitors on the magnetron filter box and H. V. Capacitor with an insulated-handle screwdriver before working in the high voltage area of the equipment compartment. Some types of failures will leave a charge in these capacitors and the discharge could cause a reflex action which could make you injure yourself.
7. In the area of the transformer, capacitor, diode, and magnetron there is HIGH VOLTAGE. When the unit is operating, keep this area clean and free of anything which could possibly cause an arc or ground, etc.
8. Do not for any reason defeat the interlock switches. There is no valid reason for this action at any time; nor will it be condoned by Maytag.
9. **IMPORTANT:** Before returning a microwave to a customer, check for proper switch interlock action. The primary and secondary switches **MUST** open when the door is actuated. The monitor switch **MUST** close at a 1/4 inch when the door is opened.
10. Before returning a microwave to a customer, verify the door spacing is reasonably uniform along the top, bottom, and sides, and that it measures 1/8 inch or less.
11. The microwave oven should never be operated with:
 - Any components removed and/or bypassed.
 - Any of the safety interlocks failing.
 - Any of the seal surfaces failing, missing, or damaged.
12. To ensure that the unit does not emit excessive microwave leakage and to meet the Department of Health Human Service guidelines, check the oven for microwave leakage using Narda Model 8100, 8200, Holaday HI1500, HI1501 or Simpson 380M leakage monitor as outlined in the instructions. The maximum leakage level allowed is 4mW/cm².
13. If servicer encounters an emission reading over 4 mW/cm², the servicer is to cease repair and contact the Maytag Service Department immediately for further direction. Maytag will contact the proper Government Agency upon verification of the test results.

Microwave Leakage Testing

WARNING

Check for radiation leakage after servicing. Should the leakage be more than 4mW/cm² inform Maytag immediately. After repairing or replacing any radiation safety device, keep a written record for future reference, as required by D.H.H.S. and HEW regulations. This requirement must be strictly observed. In addition, the leakage reading must be recorded on the service repair ticket while in the customer's home.

Equipment

- Electromagnetic radiation monitor
- 600 cc glass beaker

Procedure For Measuring Radiation Leakage

Note before measuring -

- Do not exceed meter full scale deflection. Leak monitor should initially be set to the highest scale.
 - To prevent false readings the test probe should be held by the grip portion of the handle only.
 - The scan speed is equal to one inch per antenna revolution or one inch per second if antenna speed is unknown.
 - Areas to be checked are all door seal areas and any venting parts.
 - Leakage with the outer panel removed...4mW/cm² or less.
 - Leakage for fully assembled oven with door normally closed ...4mW/cm² or less.
 - Leakage for a fully assembly oven (before the latch switch (primary) is interrupted) while pulling the door ... 4mW/cm² or less.
1. Pour 275 ±15 cc (9 oz ±1/2 oz) of 20 ± 5°C (68 ± 9°F) water in a beaker which is graduated to 600 cc and place the beaker in the center of oven.
 2. Set the radiation monitor to 2450 MHz and use it following the manufacturer's recommended test procedure to assure correct results.
 3. While measuring the leakage, always use the two inch (5 cm) spacer supplied with the probe.
 4. Press the start pad or turn on the timer and with the magnetron oscillating, measure the leakage by holding the probe perpendicular to the surface being measured.

Measurement With the Outer Panel Removed

DANGER

Avoid contacting any high voltage components.

Whenever you replace the magnetron, measure for radiation leakage before the outer panel is installed and after all necessary components are replaced or adjusted. Special care should be taken in measuring around the magnetron.

Measurement With a Fully Assembled Oven

After all components including the outer panel are fully assembled, measure for radiation leakage around the door periphery, the door viewing window, the exhaust opening, and air inlet openings.

Record Keeping and Notification After Measurement

1. After any adjustment or repair to a microwave oven, a leakage reading must be taken. Record this leakage reading on the repair ticket even if it is zero.
2. A copy of the repair ticket and the microwave leakage reading should be kept by the repair facility.

Specification Information

Item	Description		
	Model	ACM1420A*	ACM1460A*
Power Requirement	120 Volts AC 60 Hz 1,500 Watts (13A) Single phase, 3 wire grounded		
Power Output	1100 Watts full microwave power (IEC705)		
Microwave Frequency	2,450 MHz		
Timer	0 ~ 99 min. 99 sec.		
Outside Dimensions	21 7/8" (W) x 17 1/4" (H) x 12 5/8" (D)	21 7/8" (W) x 17 1/4" (H) x 12 5/8" (D)	23 7/8" (W) x 19 13/16" (H) x 13 9/16" (D)
Cavity Dimensions	14 3/4" (W) x 15 15/16" (H) x 9 7/8" (D)	14 13/16" (W) x 15 15/16" (H) x 9 7/8" (D)	17 17/32" (W) x 18 21/32" (H) x 10 7/8" (D)
Net Weight	37 lbs. (approx.)	37 lbs. (approx.)	42 lbs. (approx.)
Shipping Weight	40 lbs. (approx.)	40 lbs. (approx.)	46 lbs. (approx.)
Control Complement	Touch Control System Clock: 1:00 - 12:59 Microwave Power for Variable Cooking Power Level HIGH -----Full power throughout the cooking time 9 (Sauté) ----- approx. 90% of Full power, 8 (Reheat) ----- approx. 80% 7 (Med.-High) ----- approx. 70%, 6 (Medium) ----- approx. 60% 5 (Med.-Low) ----- approx. 50%, 4 (Defrost) ----- approx. 40% 3 (Low) ----- approx. 30%, 2 (Simmer) ----- approx. 20% 1 (Warm) ----- approx. 10%		
Nameplate Location	Front		
Accessories	Owner's manual & cooking guide Glass Turntable Rotating Ring		
This microwave oven is designed for household use only. It is not recommended for commercial purposes.			

Item	Description
	Model
Power Requirement	120 Volts AC 60 Hz 1,000 Watts (8.5 A) Single phase, 3 wire grounded
Power Output	700 Watts full microwave power (IEC705)
Microwave Frequency	2,450 MHz
Timer	0 ~ 99 min. 99 sec.
Outside Dimensions	17 15/16" (W) x 11 3/16" (H) x 12 5/8" (D)
Cavity Dimensions	12 3/16" (W) x 7 31/32" (H) x 11 5/8" (D)
Net Weight	25 lbs. (approx.)
Shipping Weight	27 lbs. (approx.)
Control Complement	Touch Control System Clock: 1:00 - 12:59 Microwave Power for Variable Cooking Power Level HIGH -----Full power throughout the cooking time 9 (Sauté) ----- approx. 90% of Full power, 8 (Reheat) ----- approx. 80% 7 (Med.-High) ----- approx. 70%, 6 (Medium) ----- approx. 60% 5 (Med.-Low) ----- approx. 50%, 4 (Defrost) ----- approx. 40% 3 (Low) ----- approx. 30%, 2 (Simmer) ----- approx. 20% 1 (Warm) ----- approx. 10%
Nameplate Location	Front
Accessories	Owner's manual & cooking guide Glass Turntable Rotating Ring
This microwave oven is designed for household use only. It is not recommended for commercial purposes.	

Specification Information

Item	Description	
Model	ACM0720A*	ACM1120A*
Power Requirement	120 Volts AC 60 Hz 1,050 Watts (9.3A) Single phase, 3 wire grounded	120 Volts AC 60 Hz 1,500 Watts (13A) Single phase, 3 wire grounded
Power Output	700 Watts full microwave power (IEC705)	1100 Watts full microwave power (IEC705)
Microwave Frequency	2,450 MHz	
Timer	0 ~ 99 min. 99 sec.	
Outside Dimensions	19" (W) x 11" (H) x 12 7/8" (D)	20 7/8" (W) x 12 3/8" (H) x 15 1/2" (D)
Cavity Dimensions	12 1/4" (W) x 7 3/4" (H) x 12 1/2" (D)	13 3/4" (W) x 8 3/4" (H) x 14 5/8" (D)
Net Weight	25 lbs. (approx.)	35 lbs. (approx.)
Shipping Weight	27 lbs. (approx.)	39 lbs. (approx.)
Control Complement	Touch Control System Clock: 1:00 - 12:59 Microwave Power for Variable Cooking Power Level HIGH ----- Full power throughout the cooking time 9 (Sauté) ----- approx. 90% of Full power, 8 (Reheat) ----- approx. 80% 7 (Med.-High) ----- approx. 70%, 6 (Medium) ----- approx. 60% 5 (Med.-Low) ----- approx. 50%, 4 (Defrost) ----- approx. 40% 3 (Low) ----- approx. 30%, 2 (Simmer) ----- approx. 20% 1 (Warm) ----- approx. 10%	
Nameplate Location	Front	
Accessories	Owner's manual & cooking guide Glass Turntable Rotating Ring	
This microwave oven is designed for household use only. It is not recommended for commercial purposes.		

Item	Description	
Model	ACM0860A*	MMC5086AA*
Power Requirement	120 Volts AC 60 Hz 1,200 Watts (10.5 A) Single phase, 3 wire grounded	
Power Output	800 Watts full microwave power (IEC705)	
Microwave Frequency	2,450 MHz	
Timer	0 ~ 99 min. 99 sec.	
Outside Dimensions	19" (W) x 11" (H) x 12 7/8" (D)	
Cavity Dimensions	12 1/4" (W) x 7 3/4" (H) x 12 1/2" (D)	
Net Weight	25 lbs. (approx.)	
Shipping Weight	27 lbs. (approx.)	
Control Complement	Touch Control System Clock: 1:00 - 12:59 Microwave Power for Variable Cooking Power Level HIGH ----- Full power throughout the cooking time 9 (Sauté) ----- approx. 90% of Full power, 8 (Reheat) ----- approx. 80% 7 (Med.-High) ----- approx. 70%, 6 (Medium) ----- approx. 60% 5 (Med.-Low) ----- approx. 50%, 4 (Defrost) ----- approx. 40% 3 (Low) ----- approx. 30%, 2 (Simmer) ----- approx. 20% 1 (Warm) ----- approx. 10%	
Nameplate Location	Front	
Accessories	Owner's manual & cooking guide Glass Turntable Rotating Ring	
This microwave oven is designed for household use only. It is not recommended for commercial purposes.		

General Information

Placement of the Oven

This microwave can be easily placed in the kitchen, family room, or anywhere else in the house. Place the oven on a flat surface such as a kitchen countertop or a specially designed microwave oven cart. Do not place oven above a gas or electric range. Free air flow around the oven is important.

Do Not Block Air Vents

All air vents must be kept clear during cooking. If air vents are covered during operation the oven may overheat. In this case, a sensitive thermal safety device automatically turns the oven off. The oven will be inoperable until the oven has cooled sufficiently.

Location of Model Number

To request service information or replacement parts, the service center will require the complete model, serial, and manufacturing number of your microwave oven. The number is located on the oven front as shown in the illustration below.

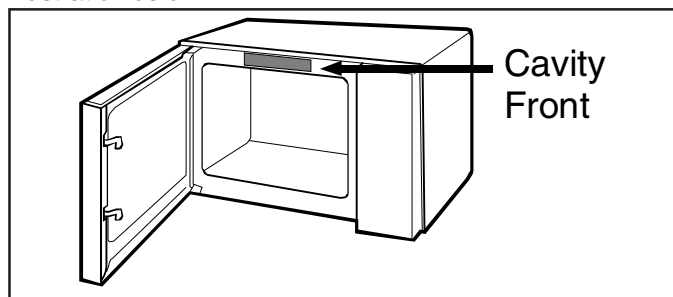

Model Identification

Complete enclosed registration card and promptly return. If registration card is missing:

- For Amana product call 1-800-843-0304 or visit the Web Site at www.amana.com
- For Maytag product call 1-800-688-9900 or visit the Web Site at www.maytag.com
- For Jenn-Air product call 1-800-536-6247 or visit the Web Site at www.jennair.com
- For product in Canada call 1-866-587-2002 or visit the Web Sites at www.amana.com or www.maytag.com or www.jennair.com

When contacting provide product information located on rating plate. Record the following:

Model Number: _____
Manufacturing Number: _____
Serial or S/N Number: _____
Date of purchase: _____
Dealer's name and address: _____

Service

Keep a copy of sales receipt for future reference or in case warranty service is required. To locate an authorized servicer:

- For Amana product call 1-800-628-5782 or visit the Web Site at www.amana.com
- For Maytag/Jenn-Air product call 1-800-462-9824 or visit the Web Site at www.maytag.com or www.jennair.com
- For product in Canada call 1-866-587-2002 or visit the Web Sites at www.amana.com or www.maytag.com or www.jennair.com

Warranty service must be performed by an authorized servicer. We also recommend contacting an authorized servicer, if service is required after warranty expires.

Parts and Accessories

Purchase replacement parts and accessories over the phone. To order accessories for your product call:

- For Amana product call 1-877-232-6771 or visit the Web Site at www.amana.com
- For Maytag/Jenn-Air product call 1-800-462-9824 or visit the Web Site at www.maytag.com or www.jennair.com
- For product in Canada call 1-866-587-2002 or visit the Web Sites at www.amana.com or www.maytag.com or www.jennair.com

Extended Service Plan

We offer long-term service protection for this new oven.

- Asure™ Extended Service Plan is specially designed to supplement Amana's strong warranty. This plan covers parts, labor, and travel charges. Call 1-866-232-6244 for information.
- Dependability PlusSM Extended Service Plan is specially designed to supplement Maytag's and Jenn-Air's strong warranty. This plan covers parts, labor, and travel charges. Call 1-800-925-2020 for information.

Radio Interference

1. Microwave oven operation may interfere with the radio or TV reception.
2. When there is interference, it may be reduced or eliminated by taking the following measures:
 - Clean the door and the seal surface of the oven.
 - Re-orient the receiving antenna of the radio or TV.
 - Relocate the microwave oven in relation to the radio or TV.
 - Move the microwave away from the receiver.
 - Plug the microwave into a different outlet so that the microwave and receiver are on different branch circuits.

General Information

Electrical Requirements

The oven is designed to operate on a Standard 120 VAC, 60 Hz household outlet. Be sure the circuit is at least 15 or 20 A and the microwave oven is the only appliance on the circuit. It is not designed for 50 Hz or any circuit other than a 120 VAC, 60 Hz circuit.

- Electrical Rating of the Oven: 120 VAC, 60 Hz

Cleaning

Before cleaning the oven, unplug the power supply cord. If impossible, open the oven door to prevent an accidental oven start.

Inside of the Oven

Use a damp cloth to wipe out crumbs and spillovers. It is important to keep the area between door and cavity front clean to assure a tight seal. Remove greasy spatters with a sudsy cloth, then rinse and dry. Do not use harsh detergent or abrasive cleaners.

Glass Tray

The glass tray can be washed by hand or in the dishwasher.

Control Panel

Wipe with a damp cloth followed immediately by a dry cloth. The Child Lock feature is also useful when cleaning the control panel. Child Lock prevents accidental programming when wiping the control panel (if so equipped).

Door

If steam accumulates inside or around the outside of the oven door, wipe the panel with a soft cloth. This may occur when the microwave oven is operated under high humidity conditions and in no way indicates a malfunction of the unit.

Outside Oven Surface

Clean with damp cloth. To prevent damage to the operating parts inside the oven, the water should not be allowed to seep into the ventilation openings.

After cleaning the oven, be sure that the rotating ring and the glass tray are in the right position. Press the STOP/ CLEAR pad twice to reset any accidental key setting.

Grounding Instructions

This appliance must be grounded. If an electrical short circuit occurs, grounding reduces the risk of electric shock by providing an escape wire for the electric current. The cord for this appliance has a grounding wire with a grounding plug. Put the plug into an outlet that is properly installed and grounded.

 **WARNING**

To avoid risk of electric shock, personal injury or death, use grounding plug properly.

Ask a qualified electrician if you do not understand the grounding instructions or if you wonder whether the appliance is properly grounded.

Keep the electrical power cord dry and do not pinch or crush it in any way.

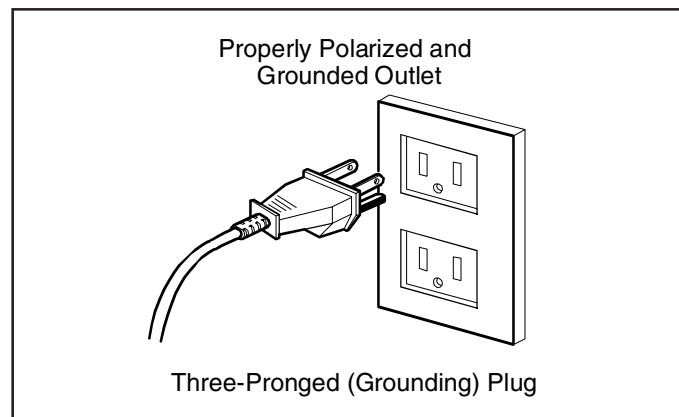

For a permanently connected appliance: This appliance must be connected to a grounded, metallic, permanent wiring system, or an equipment grounding conductor should be run with the circuit conductors and connected to the equipment grounding terminal or lead on the appliance.

General Information

Microwave Oven Description

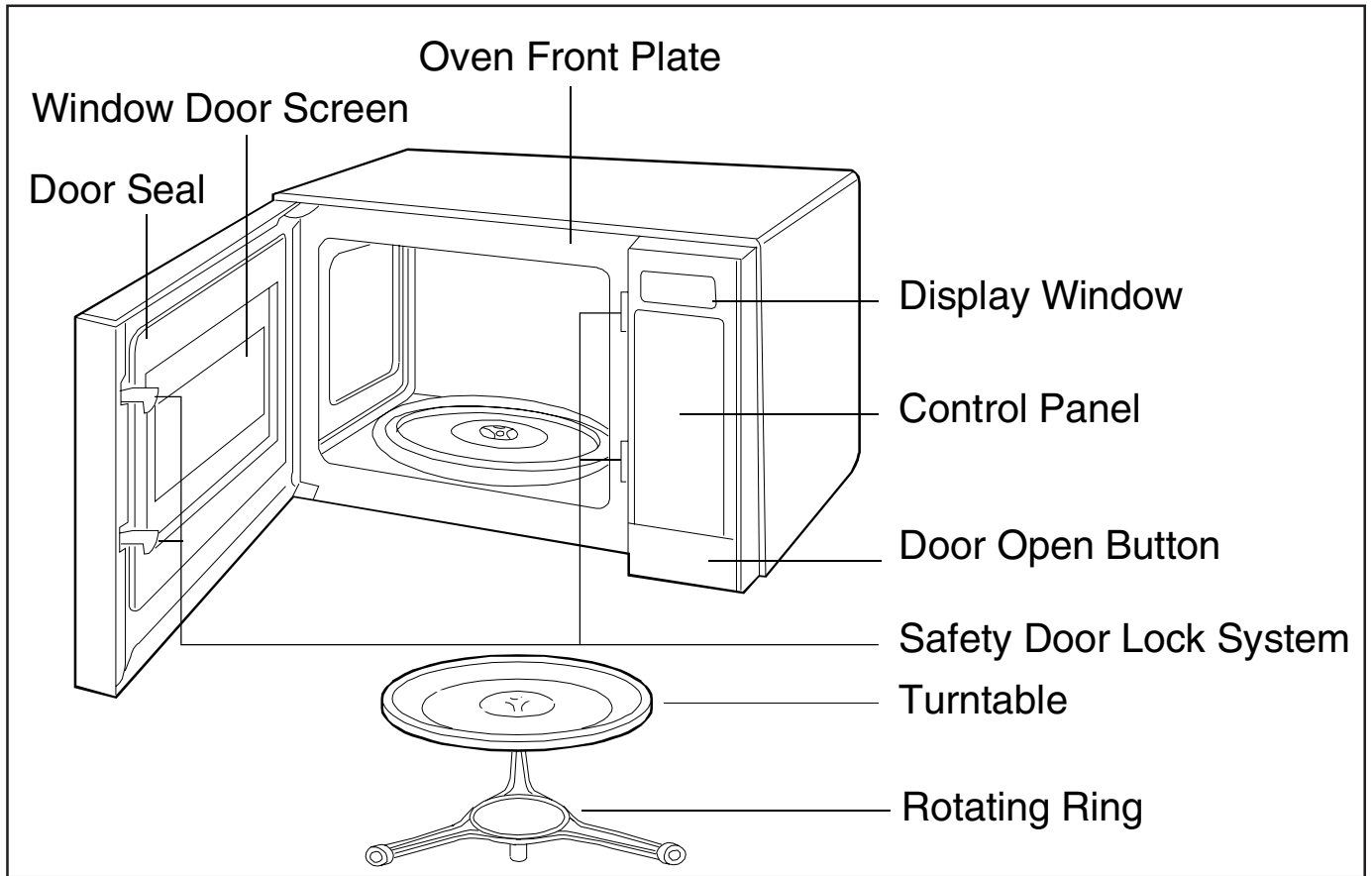

Testing Procedures



WARNING

Disconnect power before performing the following procedures unless testing requires power.

NOTES:

- Perform microwave energy leakage test if unit is serviced for any reason.
- Verify wire leads are connected to correct positions.
- When removing wire terminal plugs from connectors, grasp the connector, not the wires.

Primary Interlock Switch Test

When the door is opened slowly, an audible click should be heard. If the latch does not activate the switch when the door is closed, the switch should be adjusted in accordance with the adjustment procedure.

1. Disconnect power to oven and remove outer case, (see "Outer Case" section in Disassembly Procedure).
2. Remove control panel, (see "Control Panel" section in Disassembly Procedure).
3. Discharge high voltage capacitor, (see "High Voltage Capacitor" section in Disassembly Procedure).
4. Disconnect wire leads from switch.
5. Perform a continuity test by connecting one meter lead on COM terminal and the other meter lead on NO terminal.

Readings should be as follows:

Door closed 0 ohms
Door opened Infinite ohms

NOTE: When replacing component use identical replacement part.

NOTE: After repairing the door or the interlock system, it is necessary to do a continuity test before operating the oven.

Secondary Interlock Switch Test

When the door is opened slowly, an audible click should be heard. If the latch does not activate the switch when the door is closed, the switch should be adjusted in accordance with the adjustment procedure.

1. Disconnect power to oven and remove outer case, (see "Outer Case" section in Disassembly Procedure).
2. Remove control panel, (see "Control Panel" section in Disassembly Procedure).
3. Discharge high voltage capacitor, (see "High Voltage Capacitor" section in Disassembly Procedure).
4. Disconnect wire leads from switch.
5. Perform a continuity test by connecting one meter lead on COM terminal and the other meter lead on NO terminal.

Readings should be as follows:

Door closed 0 ohms
Door opened Infinite ohms

NOTE: When replacing component use identical replacement part.

NOTE: After repairing the door or the interlock system, it is necessary to do a continuity test before operating the oven.

Interlock Monitor Switch Test

When the door is opened slowly, an audible click should be heard. If the latch does not activate the switch when the door is closed, the switch should be adjusted in accordance with the adjustment procedure.

1. Disconnect power to oven and remove outer case, (see "Outer Case" section in Disassembly Procedure).
2. Remove control panel, (see "Control Panel" section in Disassembly Procedure).
3. Discharge high voltage capacitor, (see "High Voltage Capacitor" section in Disassembly Procedure).
4. Disconnect wire leads from switch.
5. Perform a continuity test by connecting one meter lead on COM terminal and the other meter lead on NC terminal.

Readings should be as follows:

Door closed Infinite ohms
Door opened 0 ohms

NOTE: When replacing component use identical replacement part.

NOTE: After repairing the door or the interlock system, it is necessary to do a continuity test before operating the oven.

Magnetron

1. Disconnect power to oven and remove outer case, (see "Outer Case" section in Disassembly Procedure).
2. Discharge high voltage capacitor, (see "High Voltage Capacitor" section in Disassembly Procedure).
3. Disconnect wire leads to magnetron.
4. Measure the resistance across filament terminals of the magnetron.
Reading should be less than 1 ohm.
5. Measure the resistance from each filament terminal to ground. Reading should indicate infinite ohms.

NOTE: Any other readings than what should be indicated, magnetron needs to be replaced.

NOTE: Replace the magnetron if magnetron indications are OK and all other high voltage components test good (but the unit does not sufficiently heat).

Testing Procedures



WARNING

Disconnect power before performing the following procedures unless testing requires power.

High Voltage Diode

1. Disconnect power to oven and remove outer case, (see "Outer Case" section in Disassembly Procedure).
2. Discharge high voltage capacitor, (see "High Voltage Capacitor" section in Disassembly Procedure).
3. Disconnect wire leads to high voltage diode.
4. Measure resistance of diode with meter leads. Reverse meter leads and measure again. Normal reading would be continuity in one direction and infinity in the other. An abnormal reading would be continuity or infinity in both directions.

High Voltage Transformer

1. Disconnect power to oven and remove outer case, (see "Outer Case" section in Disassembly Procedure).
2. Discharge high voltage capacitor, (see "High Voltage Capacitor" section in Disassembly Procedure).
3. Disconnect wire leads to high voltage transformer.
4. Measure resistance of the terminals on the high voltage transformer with meter on R x 1 scale.

ACM1120, ACM1420, ACM1460, ACM2160 reading should be indicated as follows:

Primary winding approximately 0.2 to 0.4 ohm
Filament winding less than 1 ohm
Secondary winding .. approximately 60 to 90 ohm

ACM0720, ACM0860, MMC5086, UMC1061, UMC5200 reading should be:

Primary winding approximately 0.3 to 0.8 ohm
Filament winding less than 1 ohm
Secondary winding . approximately 100 to 200 ohm

5. Measure resistance of the terminals on the high voltage transformer with meter on high scale.

ACM0720, ACM0860, ACM1120, ACM1420, ACM1460, ACM2160, MMC5086, UMC1061 reading should be indicated as follows:

Primary winding to ground Infinite ohms
Filament winding to ground Infinite ohms

Fan Motor

1. Disconnect power to oven and remove outer case, (see "Outer Case" section in Disassembly Procedure).
2. Discharge high voltage capacitor, (see "High Voltage Capacitor" section in Disassembly Procedure).
3. Disconnect wire terminals from fan motor.
4. Measure resistance of fan motor from terminal to terminal.

ACM0720, UMC1061, UMC5200 reading should be indicated as follows:

Terminal A to terminal B 65 – 80 ohms
Terminal B to terminal C 10 – 30 ohms
Terminal A to terminal C 85 – 105 ohms

- **Abnormal reading**—Infinite or several ohms

ACM0860, ACM1120, ACM1420, ACM1460, ACM2160, MMC5086 reading should be indicated as follows:

Terminal A to terminal C 85 – 100 ohms
Terminal B to terminal C 10 – 25 ohms

- **Abnormal reading**—Infinite or several ohms

Turntable Motor

1. Disconnect power to oven and remove turntable glass.
2. Turn unit on its side and remove turntable motor cover.
3. Disconnect wire terminals from turntable motor.
4. Measure resistance of turntable motor from terminal to terminal.
 - **Normal reading**—Approximately 100 – 150 ohms
 - **Abnormal reading**—Infinite or several ohms

High Voltage Capacitor

1. Disconnect power to oven and remove outer case, (see "Outer Case" section in Disassembly Procedure).
2. Discharge high voltage capacitor, (see "High Voltage Capacitor" section in Disassembly Procedure).
3. Disconnect wire leads to high voltage capacitor.
4. Measure resistance of capacitor from terminal to terminal.
 - **Normal reading**—momentarily indicates several ohms and then gradually returns to infinite ohms.
 - **Abnormal reading**—Indicates continuity or infinite ohms.
5. Measure resistance of capacitor from terminal to case.
 - **Normal reading**—Indicates infinite ohms
 - **Abnormal reading**—Indicates continuity

Humidity Sensor

1. Disconnect power to oven and remove outer case, (see "Outer Case" section in Disassembly Procedure).
2. Discharge high voltage capacitor, (see "High Voltage Capacitor" section in Disassembly Procedure).
3. Disconnect wire terminal plug from control board.
4. Measure the following terminals with meter on R x 1000 scale.

Normal reading:

Old Models New Models

Terminal 1 to 2 718 ohms 5.1 K ohms
Terminal 2 to 3 718 ohms 2.1 K ohms
Terminal 1 to 3 5 ohms 2.1 K ohms

Abnormal reading—Infinite or several ohms

NOTE: Unit should be plugged in for at least 5 minutes before operating sensor cooking. Room temperature should not exceed 95°F. Oven does not generate microwave energy for the first 28 seconds of operation.

Testing Procedures



WARNING

Disconnect power before performing the following procedures unless testing requires power.

Relay

1. Disconnect power to oven and remove control panel, (see "Control Panel" section in Disassembly Procedure).
2. Discharge high voltage capacitor, (see "High Voltage Capacitor" section in Disassembly Procedure).
3. Disconnect wire terminal plug from control board relay (RY2), and connect meter leads to terminals shown below on R x 1 scale and operate the unit.

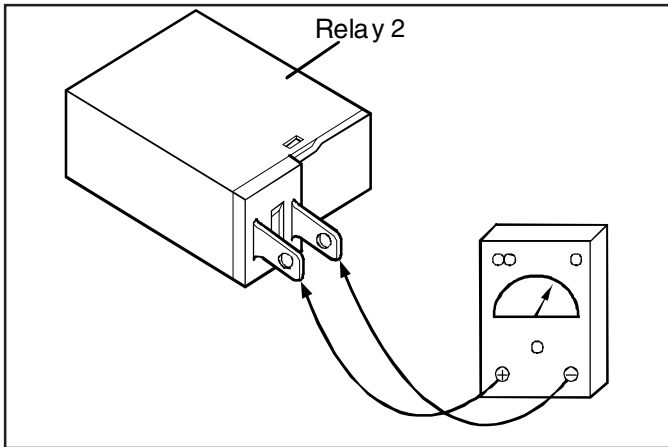

Power Level	Cycles On for:	Cycles Off for:
1	4 seconds	18 seconds
2	6 seconds	16 seconds
3	8 seconds	14 seconds
4	10 seconds	12 seconds
5	12 seconds	10 seconds
6	14 seconds	8 seconds
7	16 seconds	6 seconds
8	18 seconds	4 seconds
9	20 seconds	2 seconds
10	22 seconds	0 seconds

Oven Thermostat

1. Disconnect power to oven and remove outer case, (see "Outer Case" section in Disassembly Procedure).
2. Discharge high voltage capacitor, (see "High Voltage Capacitor" section).
3. Remove outer case, (see "Outer Case" section).
4. Remove screws securing air duct to oven cavity.
5. Disconnect wires from oven thermostat.
6. Measure resistance from terminal to terminal. Meter should read approximately 0.5 ohms. Any other indication replace oven thermostat.

Listed below are temperature settings for the thermostat.

Unit	Open	Closed
ACM0720	230°F	140°F
ACM0860	194°F	167°F
ACM1120		
ACM1420		
ACM1460		
ACM2160		
MMC5086		
UMC1061		
UMC5200		

Fuse

NOTE:

Before replacing a blown monitor fuse, test the primary interlock switch, secondary interlock switch, monitor switch, and power relay contacts for proper operation. If the monitor fuse is blown by a failed switch operation, all switches and printed circuit board must be replaced.

Problem:

- Fuse blows immediately after oven door is opened or closed.
Improper operation of primary, secondary and/or monitor switches
- Fuse blows when oven door is closed and **START** pad is pressed.
Malfunction of the high voltage transformer, high voltage capacitor including the diode, magnetron, blower motor or circuit board.

Testing Procedures



WARNING

Disconnect power before performing the following procedures unless testing requires power.

Control Key Panel

1. Disconnect power to oven and remove outer case, (see "Outer Case" section in Disassembly Procedure).
2. Remove control panel, (see "Control Panel" section in Disassembly Procedure).
3. Discharge high voltage capacitor, (see "High Voltage Capacitor" section in Disassembly Procedure).
4. Disconnect ribbon connector by sliding top part of connector upward. Once in released position remove ribbon from connector by sliding ribbon side-to-side.

NOTE: Caution should be used when removing cable from connector. Ribbon cable has two holes which connector locks the ribbon in place.

Key pad matrix for ACM0720A*, UMC1061A*, UMC5200A*

<u>Pad</u>	<u>Conn.</u>	<u>Pad</u>	<u>Conn.</u>
1	1 - 8	Stop/Clear	4 - 8
2	1 - 9	Auto Defrost	4 - 9
3	1 - 10	Clock	4 - 10
4	1 - 11	Popcorn	5 - 8
5	2 - 8	Potato	5 - 9
6	2 - 9	Beverage	5 - 10
7	2 - 10	Dinner Plate	5 - 11
8	2 - 11	Fresh Vegetable	6 - 8
9	3 - 8	Frozen Entree	6 - 9
0	3 - 9	Start	6 - 10
Program	3 - 10	Timer	7 - 9
Power Level	3 - 11	Easy Cook	7 - 10

Key pad matrix for ACM1120A* and ACM1420A*

<u>Pad</u>	<u>Conn.</u>	<u>Pad</u>	<u>Conn.</u>
Clock	1 - 8	Beverage	5 - 8
Control Set-up	1 - 9	Potato	5 - 9
More	1 - 10	Popcorn	5 - 10
Less	1 - 11	Pizza	5 - 11
6	2 - 8	Timer	5 - 12
7	2 - 9	Auto Defrost	6 - 8
8	2 - 10	Program	6 - 9
9	2 - 11	Power Level	6 - 10
0	2 - 12	Rapid Defrost	6 - 12
Stop/Clear	3 - 8	1	7 - 8
Fresh Vegetable	3 - 9	2	7 - 9
Easy Cook	3 - 12	3	7 - 10
Frozen Entree	4 - 10	4	7 - 11
Start	4 - 11	5	7 - 12

Key pad matrix for ACM0860A*, ACM1460A*, ACM2160A*, and MMC5086A*

<u>Pad</u>	<u>Conn.</u>	<u>Pad</u>	<u>Conn.</u>
Sensor Popcorn ..	1 - 8	Start	4 - 10
Easy Cook	1 - 9	4	4 - 11
Power level	1 - 10	Control Set-up	5 - 8
1	1 - 11	8	5 - 10
Warm Hold	2 - 8	5	5 - 11
Program	2 - 10	Timer	6 - 8
2	2 - 11	More	6 - 9
Rapid Defrost	2 - 12	9	6 - 10
Sensor Cook	3 - 8	6	6 - 11
Sensor Reheat ...	3 - 9	Clock	7 - 8
Stop /Clear	3 - 10	Less	7 - 9
3	3 - 11	0	7 - 10
Auto Defrost	4 - 8	7	7 - 11
Auto Cook	4 - 9		

Troubleshooting Procedures

When you get a complaint from customers, evaluate the complaint carefully. If the following symptoms apply, instruct the customer in the proper use of the microwave oven. This can eliminate an unnecessary service call.



CAUTION

- Verify proper grounding before checking for trouble.
- Be careful of the high voltage circuit.
- Discharge the high voltage capacitor.
- When checking the continuity of the switches or of the high voltage transformer, disconnect one lead wire from these parts and then check continuity with the AC plug removed. To do otherwise may result in a false reading or damage to your meter.
- Do not touch any part of the circuit on the printed circuit board, since static electric discharge may damage the control panel. Always touch yourself to ground while working on this panel to discharge any static charge built up in your body.

Condition	Cause	Solution
Microwave oven does not work.	<ul style="list-style-type: none"> • Inserting many plugs into one outlet and using them at the same time. (blown fuse or breaker) 	<ul style="list-style-type: none"> • Avoid using other electrical appliances when you use the microwave oven.
	<ul style="list-style-type: none"> • Microwave oven plug is not inserted tightly. 	<ul style="list-style-type: none"> • Insert microwave oven plug securely.
Output power is too low.	<ul style="list-style-type: none"> • Low AC input voltage. 	<ul style="list-style-type: none"> • Use the microwave oven at adequate line voltage.
	<ul style="list-style-type: none"> • Food temperature is too low. 	<ul style="list-style-type: none"> • This may not be a defect. It is possible that the food should be cooked for a longer time period.
Sparks occur.	<ul style="list-style-type: none"> • Using metallic ware and allowing it to touch the oven wall. 	<ul style="list-style-type: none"> • Do not use metallic ware for cooking except where noted in the cooking guide.
	<ul style="list-style-type: none"> • Ceramic ware trimmed in gold or silver powder is used. 	<ul style="list-style-type: none"> • Do not use any type of cookware with metallic trimming.
Uneven cooking.	<ul style="list-style-type: none"> • Inconsistent intensity of microwave by their characteristics. 	<ul style="list-style-type: none"> • Use plastic wrap or lid. • Stir once or twice while cooking soup, cocoa or milk, etc.

Troubleshooting Procedures

Trouble 1: The following visual conditions indicate a probable failed control circuit.

1. Incomplete segments.
 - Segment missing.
 - Partial segment missing.
 - Digit flickering (Note: Slight flickering is normal.)
2. Colon does not turn on or blink.
3. A distinct change in the brightness of one or more numbers in display.
4. One or more digits in the display are not lighting.
5. Display indicates a number different from one touched, for example, key in 5 and 3 appears in the display.
6. Specific numbers (for example 7 or 9) will not display when key pad is touched.
7. Display does not count down with time blinking or up with clock operation.
8. Display obviously jumps in time while counting down.
9. Display counts down too fast while cooking.
10. Each indicator light does not turn on after setting cooking cycle.
11. Display time of day does not reappear when cooking is finished.
12. Beep sound is not heard when correct pad is pressed.

Condition	Check	Result	Cause	Solution
No input can be programmed.	Check the connection between membrane key assembly and PCB assembly.	<ul style="list-style-type: none"> • Continuity • No continuity 	<ul style="list-style-type: none"> • Failed PCB assembly. • Loose connection. 	<ul style="list-style-type: none"> • Replace PCB assembly. • Connect them tightly.
<ol style="list-style-type: none"> 1. Some inputs cannot be programmed. 2. Display shows a number or figure different from one touched. 3. Random programming when touching other pads. 4. Display is fixed at some figure and can not accept any input. 	Replace key membrane assembly and check operation.	<ul style="list-style-type: none"> • Everything works as specified. • Still have trouble. 	<ul style="list-style-type: none"> • Failed key membrane assembly. • Failed PCB assembly. 	<ul style="list-style-type: none"> • Replace key membrane assembly. • Replace PCB assembly.

Troubleshooting Procedures

Trouble 2: Oven does not operate at all, display window does not display any digits, and no input is accepted.

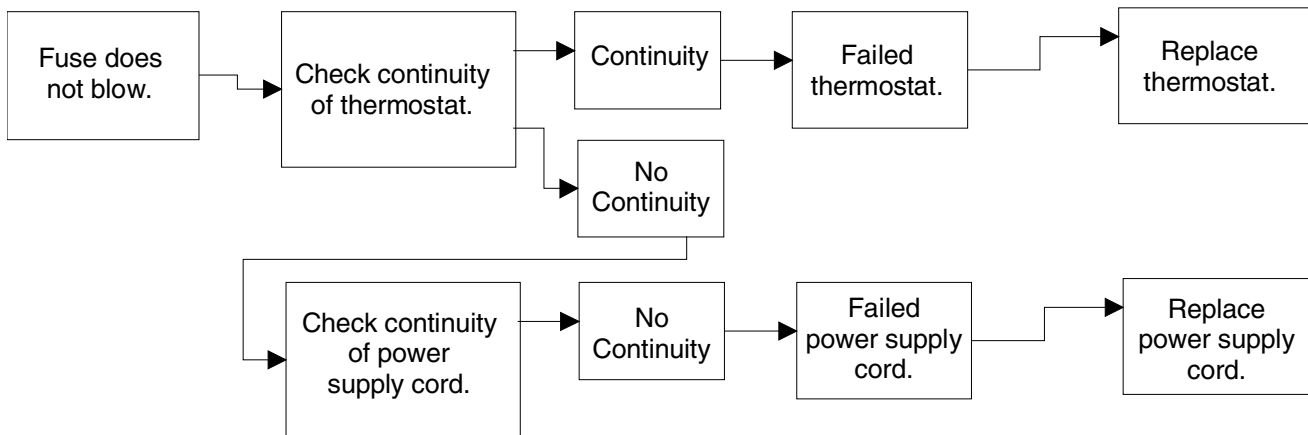
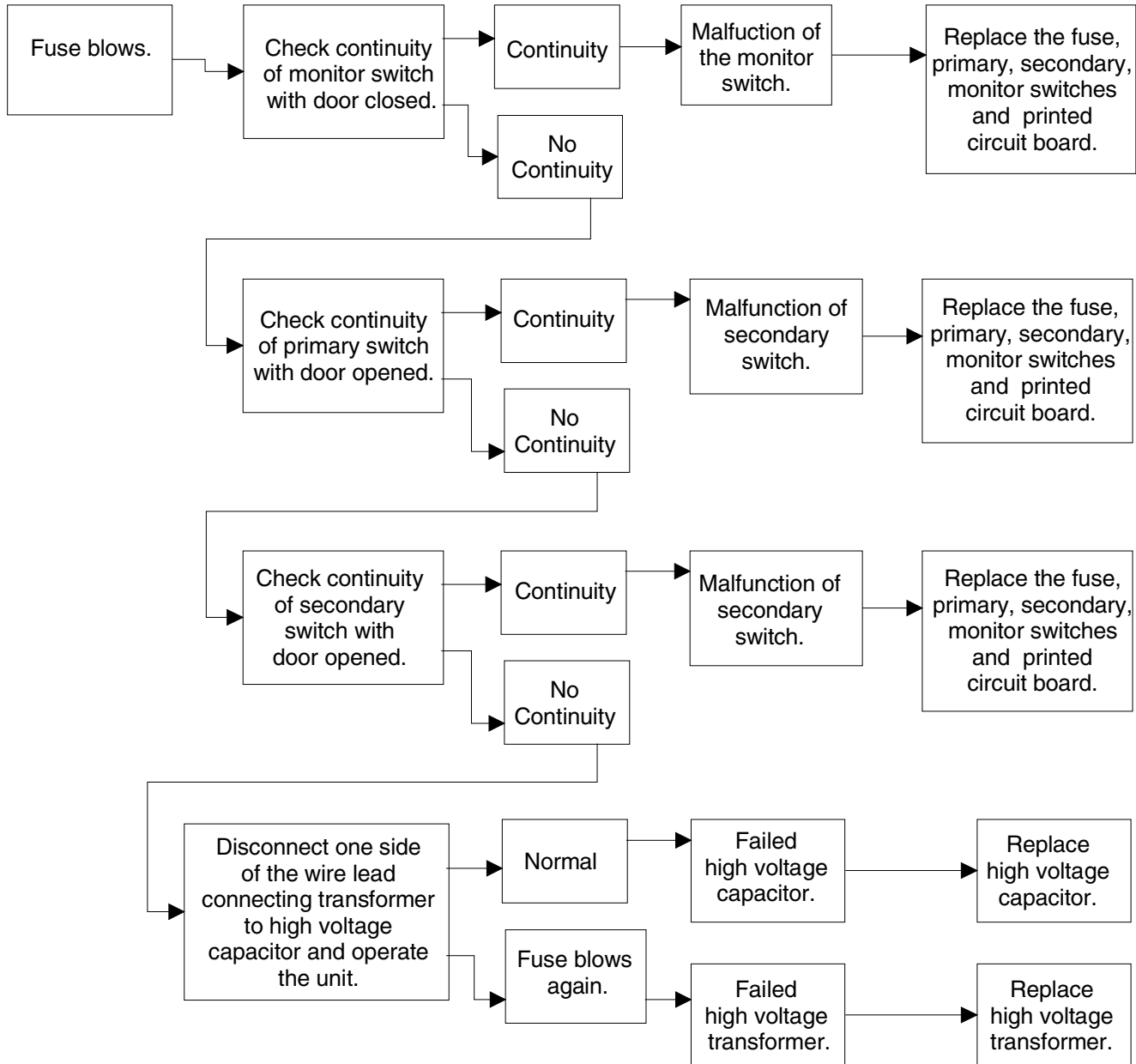

Troubleshooting Procedures

Trouble 3: Display shows all digits programmed, but does not start cooking when the START pad is pressed.

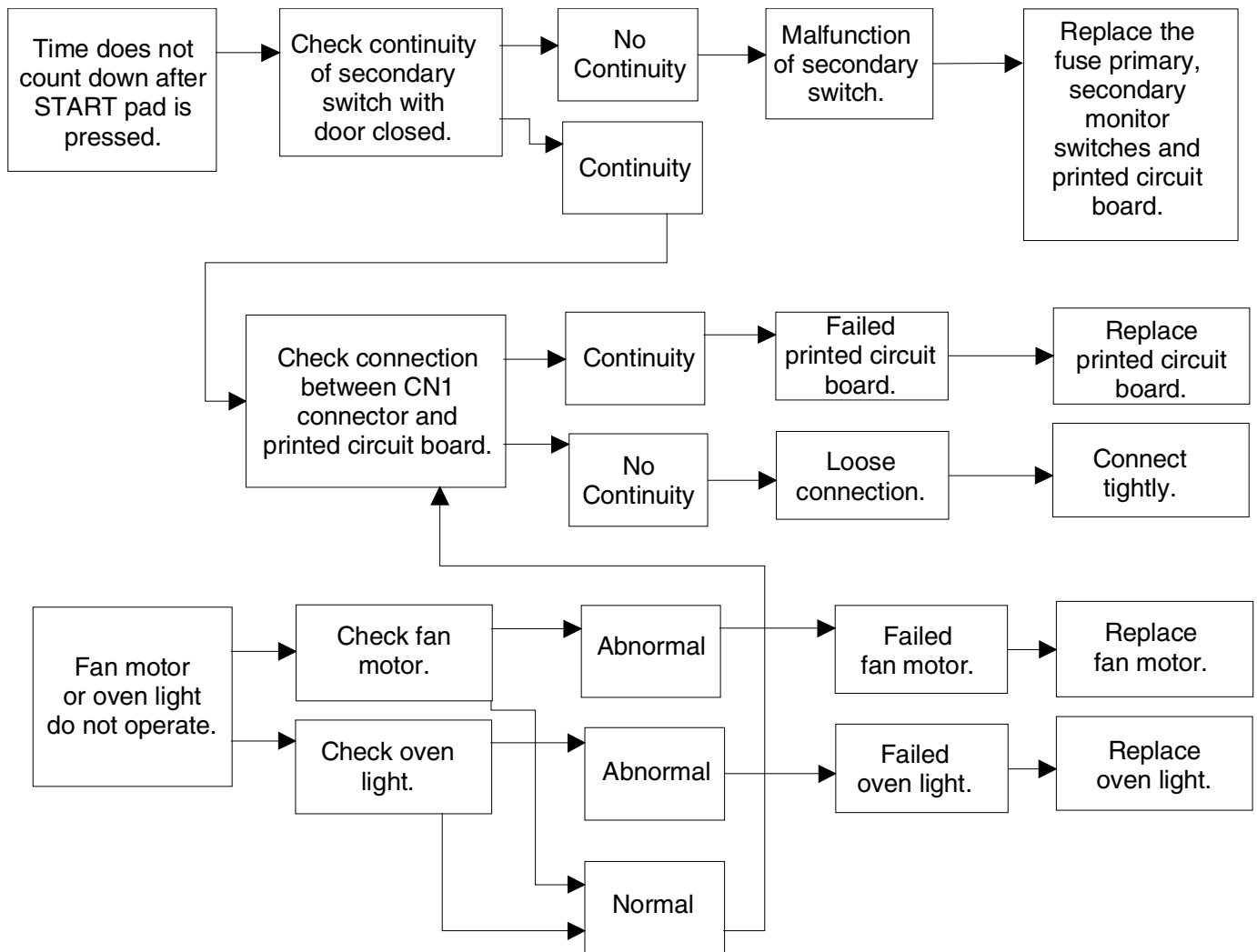

Troubleshooting Procedures

Trouble 4: Oven operates with little or no heat when operating.

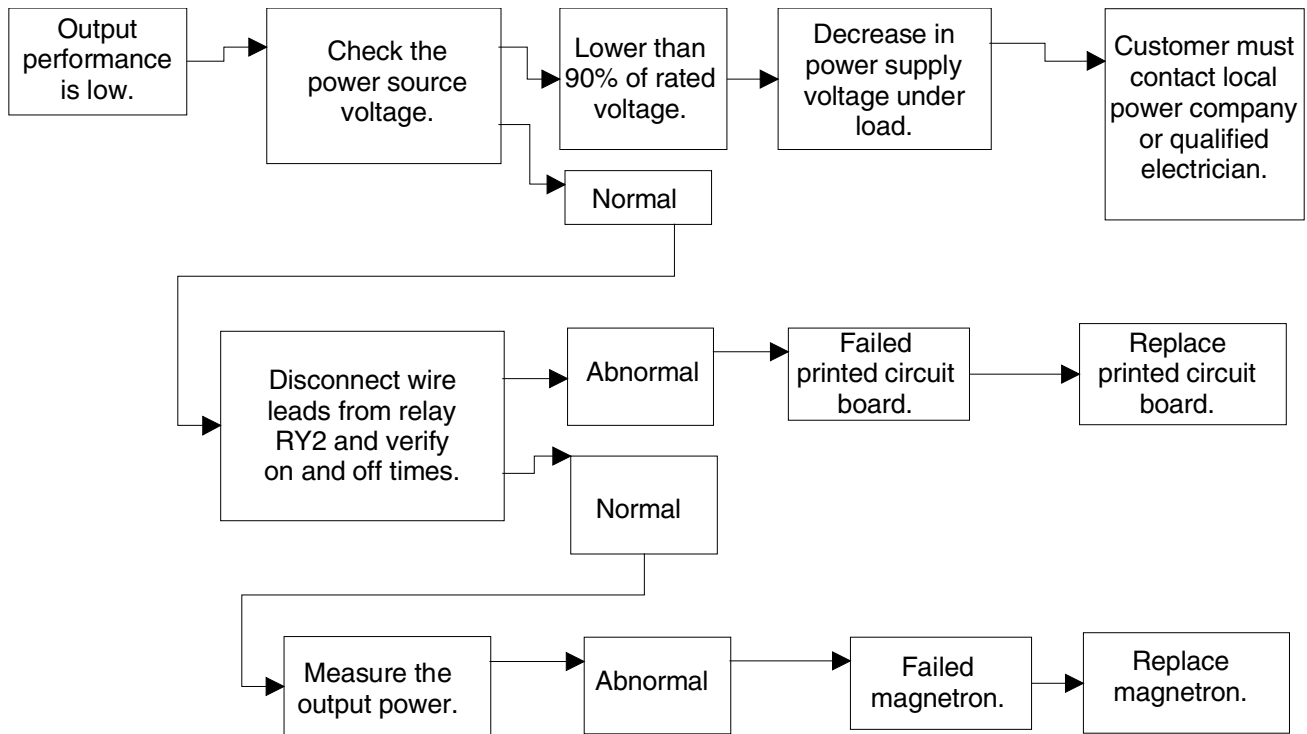

Troubleshooting Procedures

Trouble 5: No microwave oscillation even when oven light and fan motor operate.

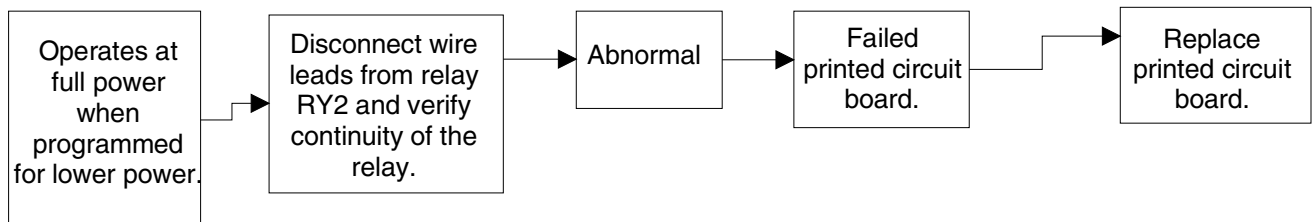
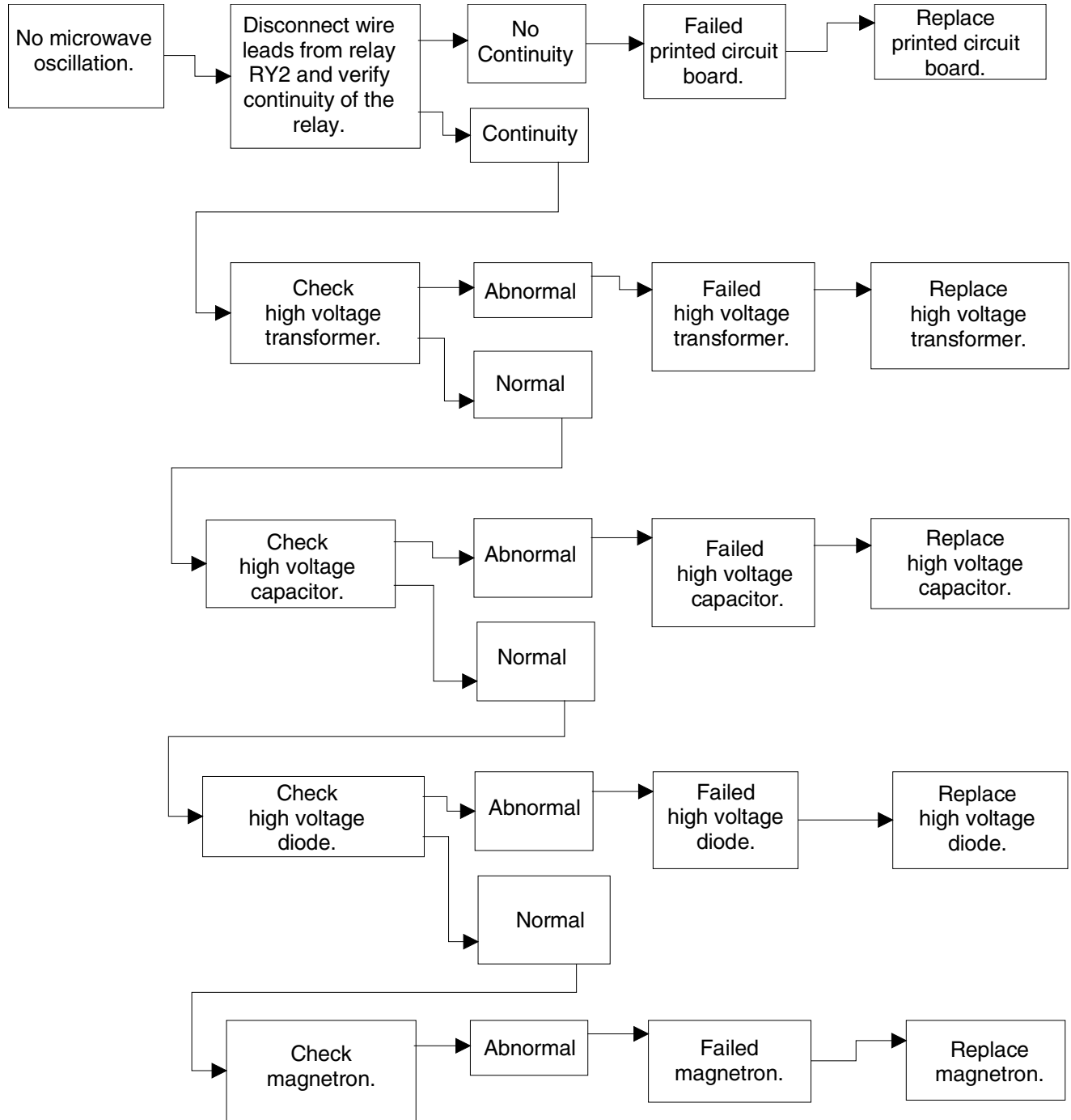

Disassembly Procedures



WARNING

High voltage is present at the high voltage terminal of the high voltage transformer during any cooking cycle.

It is neither necessary or advisable to attempt measurement of the high voltage.

Before touching any oven components or wiring, always unplug the oven from its power source and discharge capacitor.

Door Assembly



CAUTION

A microwave leakage test must be performed anytime a door assembly is removed, replaced, disassembled, or adjusted for any reason.

Door Removal

1. Disconnect power to oven.
2. Open the oven door, remove choke cover cap, or choke cover and slowly raise the door evenly. This disengages the pins at the top and bottom.

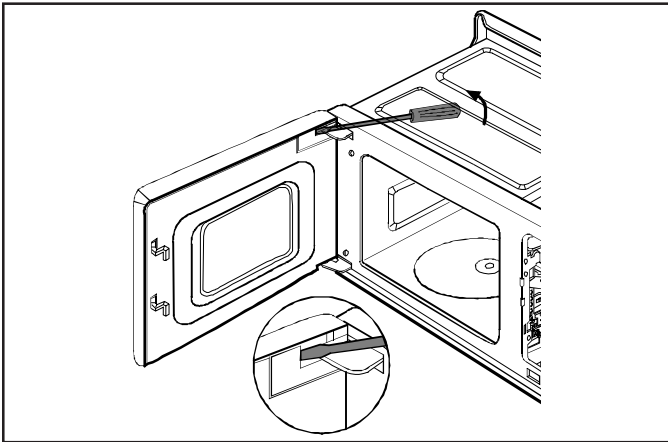

NOTE: When aligning the door for assembly, the door must be opened as much as possible.

3. To place door back on unit, place bottom pin into slot first and then align the top pin. Once pins are aligned push door downward to lock into place.
4. Replace choke cover cap to complete assembly.

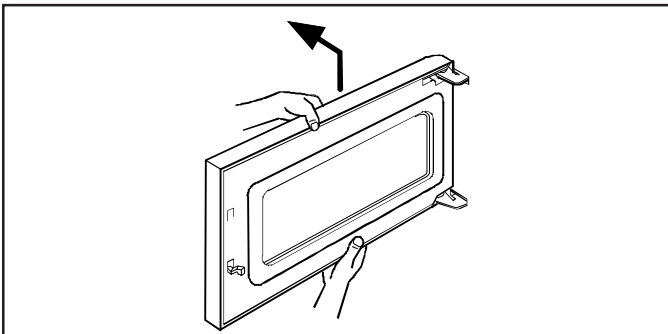

To avoid the risk of electrical shock, personal injury or death; disconnect power to oven and discharge capacitors before following any disassembly procedure.

Door Disassembly

1. Disconnect power to oven and remove oven door, see "Door Removal" procedure.
2. Pry away choke cover, by placing a tool in the upper right corner of the door and gently prying outward on the choke cover. Continue to work around the door casing until choke cover is completely loose.



CAUTION

To avoid property damage, care must be taken when prying choke cover from oven door.

3. Slide latch assembly upward and to the left to release plastic tabs from door frame. Once latch assembly is loose the spring may be disconnected from the door frame.
4. Remove screws securing door handle and door frame to door panel.
5. Remove door frame by releasing tabs around entire door panel.
6. Remove door handle by placing a hand on door panel next to the top of the door handle. Twist door panel towards the inside of door and pulling on the top portion of the door handle in a quick jerking motion.

NOTE: When replacing door handle the bottom portion of the door handle must be inserted first.

7. Slide door glass to the right slightly, then push the door glass upward to release the glass from the track.
8. Reassemble in reverse order.

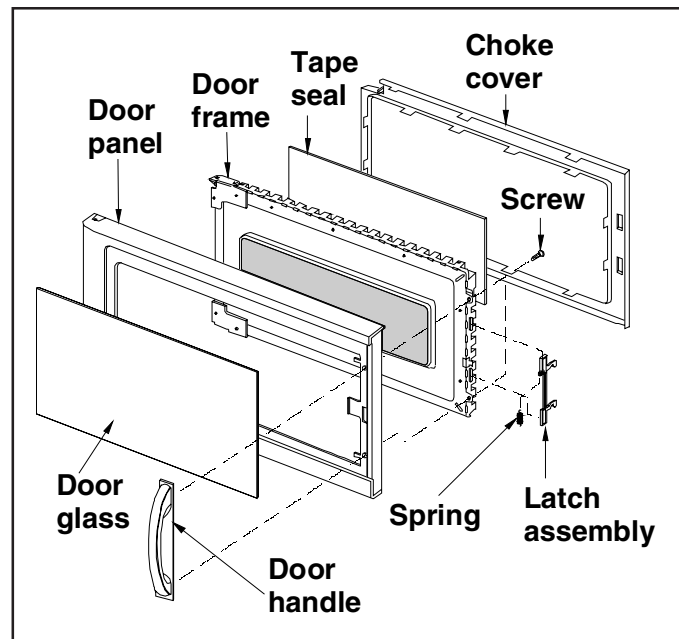

Disassembly Procedures

WARNING

To avoid the risk of electrical shock, personal injury or death; disconnect power to oven and discharge capacitors before following any disassembly procedure.

CAUTION

A microwave leakage test must be performed anytime a door assembly is removed, replaced, disassembled, or adjusted for any reason.

Outer Case

1. Disconnect power to unit.
2. Remove screws securing outer case to the unit.
3. Slide outer case towards the rear of the unit.
4. Place outer case to the side, so no damage will occur to the case.
5. Reassemble in reverse order.

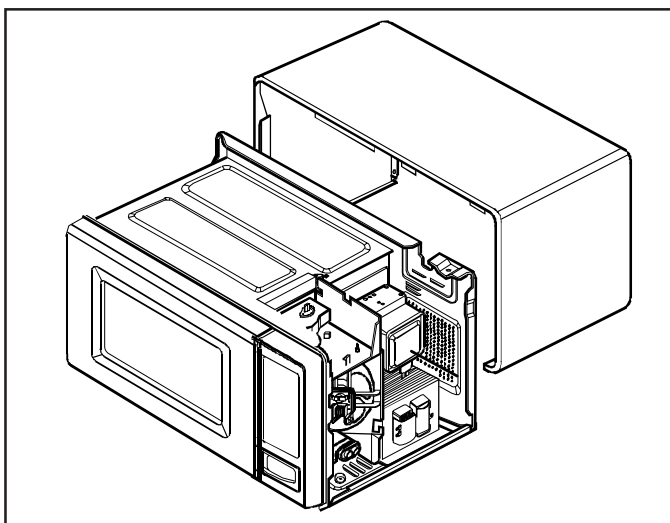

Control Panel

The control panel is made up of several components, such as p.c. board and touch panel.

Control Panel Removal

1. Disconnect power to unit and remove outer case, see "Outer Case" procedure.
2. Remove screw located at the top of touch panel. Lift control panel up and out to release bottom tab connections.

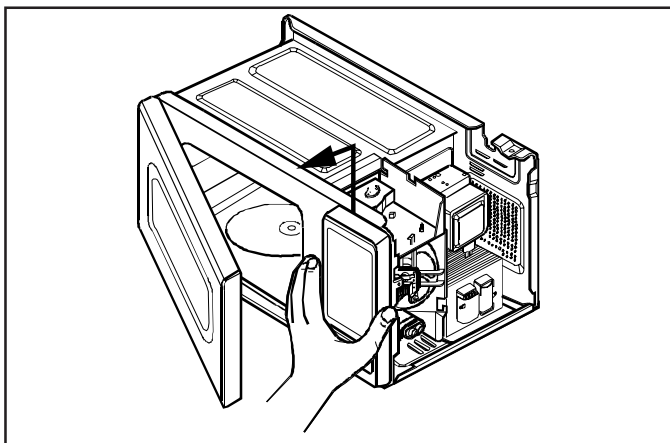

3. Place control panel on a flat surface.
4. Reassemble in reverse order.

P.C. Board

The p.c. board is located at the top on back of control panel. This board has up to five connection plugs which control the following:

CN1	Main power connector
FPC (S1)	Ribbon connector for key panel
RY2	Relay connector

P.C. Board Removal

1. Disconnect power to unit and remove outer case, see "Outer Case" procedure.
2. Remove control panel, see "Control Panel" procedure.
3. Discharge high voltage capacitor, see "High Voltage Capacitor" procedure.
4. Disconnect ribbon connector by sliding top part of connector upward. Once in released position, remove ribbon from connector by sliding ribbon side-to-side.

NOTE: Caution should be used when removing cable from connector. Ribbon cable has two holes which connector locks ribbon in place.

5. Disconnect and mark the wire connectors from p.c. board.
6. Remove screws securing p.c. board to control panel assembly.

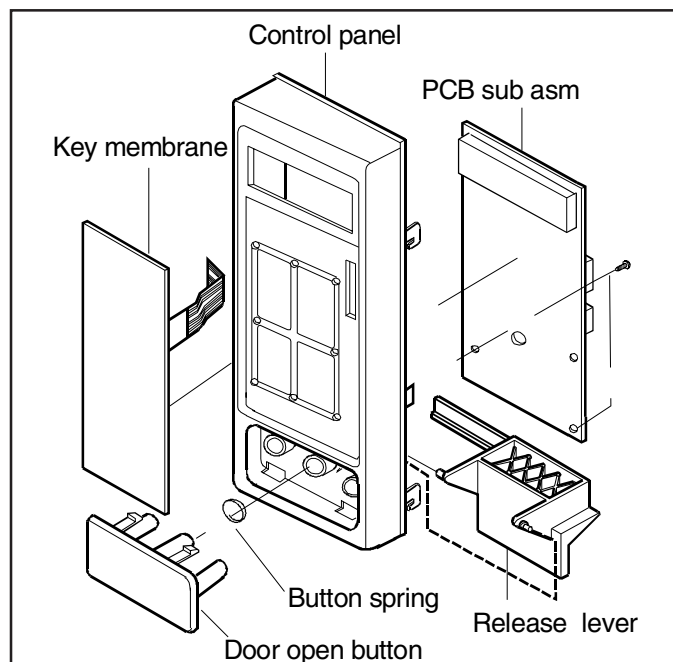

7. Reassemble in reverse order.

NOTE: Do not flex p.c. board.

Disassembly Procedures



To avoid the risk of electrical shock, personal injury or death; disconnect power to oven and discharge capacitors before following any disassembly procedure.

Control Key Panel

The key panel has one ribbon connection on the p.c. board.

The key panel pads can be checked through a continuity test. Operations of key pad can be checked by measuring connections at end of ribbon, (using high ohms scale).

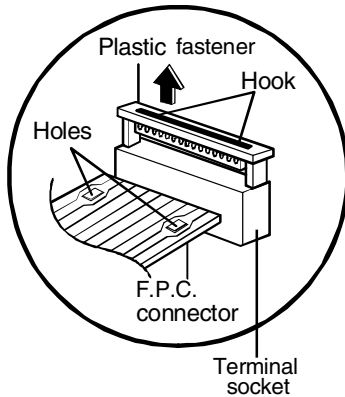

Control Key Panel Removal

1. Disconnect power to unit and remove outer case, see "Outer Case" procedure.
2. Remove control panel, see "Control Panel" procedure.
3. Discharge high voltage capacitor, see "High Voltage Capacitor" procedure.
4. Disconnect ribbon connector by sliding top part of connector upward. Once in released position remove ribbon from connector by sliding ribbon side-to-side.

NOTE: Caution should be used when removing cable from connector. Ribbon cable has two holes which connector locks ribbon in place.

5. Peel failed key pad off and replace with new key pad.
6. Reassemble in reverse order.

Interlock Door Latch Switches

Primary switch is operated by bottom latch pawl.

Interlock Switch Removal

1. Disconnect power to unit and remove outer case, see "Outer Case" procedure.
2. Remove control panel, see "Control Panel" procedure.
3. Discharge high voltage capacitor, see "High Voltage Capacitor" procedure.
4. Test interlock switches before removing, see "Testing Procedures".
5. Disconnect and label wire connections.
6. Remove interlock switch or latch board assembly. Either by releasing the connecting hooks or connecting screw.

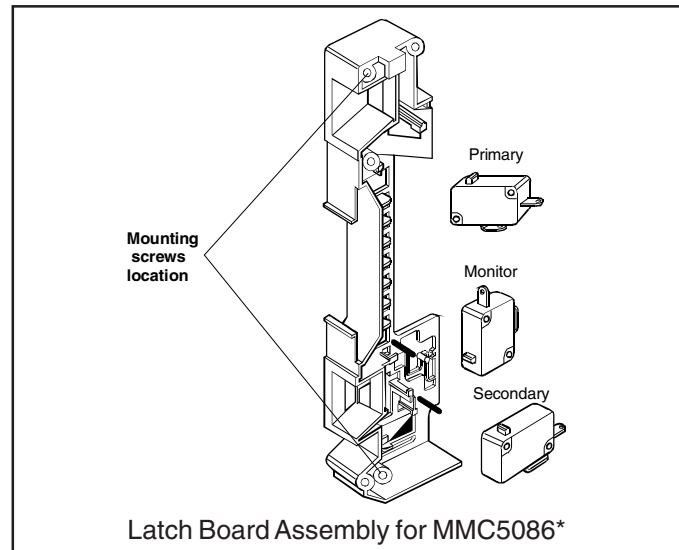
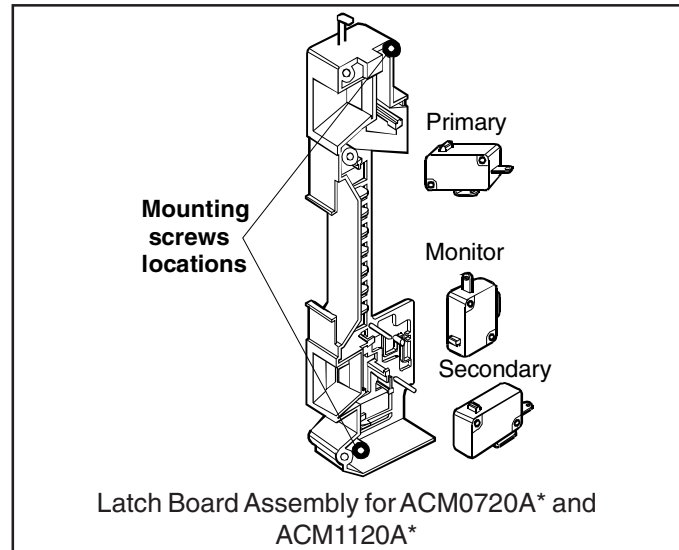
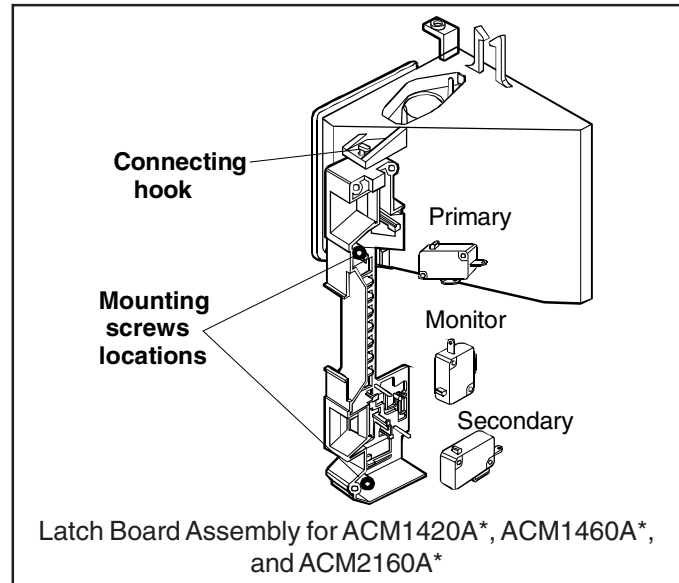

Disassembly Procedures

WARNING

To avoid the risk of electrical shock, personal injury or death; disconnect power to oven and discharge capacitors before following any disassembly procedure.

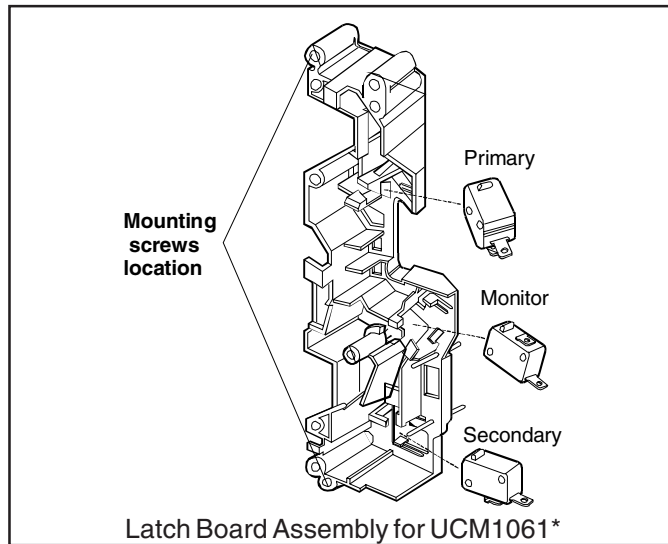

- When proper switch sequence has been achieved, tighten the latch board securely.

CAUTION

A microwave leakage test must be performed anytime a door assembly is removed, replaced, disassembled, or adjustment of latch board is made.

CAUTION

Before replacing a blown monitor fuse, test the primary interlock switch, secondary interlock switch, monitor switch, and power relay contacts for proper operation. If the monitor fuse is blown by a failed switch operation, all switches, and printed circuit board must be replaced.

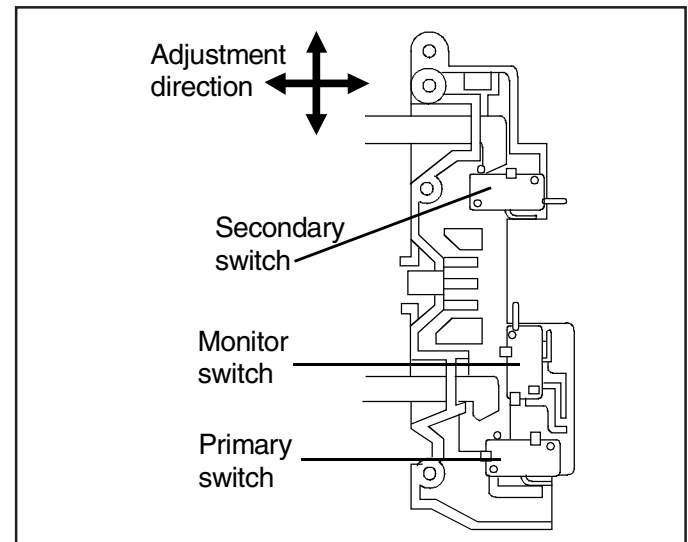

Adjusting Interlocks

The interlock monitor, primary, and secondary switches act as a final safety switch, protecting the operator from microwave energy. After adjusting the interlock monitor switches, verify they are correctly connected.

For door fit and switch operation, switch housing is adjustable.

- Disconnect power to unit and remove outer case, see "Outer Case" procedure.
- Remove control panel, see "Control Panel" procedure.
- Loosen switch mounting screw on vertical flange.
- Close oven door, move latch board upward toward the top of the oven and/or away from the door latch until gaps are less than 1/6-inch (0.5 mm).
- Hold latch board securely for proper switch operation and door fit, retighten screws.
- Open the oven door slowly, watching the switches. Verify switches release in the following order.
 - Primary interlock switch
 - Secondary interlock switch
 - Interlock monitor switch

NOTE: Adjust the latch board until all switches operate in proper sequence.

- Close the oven door slowly, watching the switches. Verify switches activate in the following order.
 - Interlock monitor switch
 - Secondary interlock switch
 - Primary interlock switch

High Voltage Capacitor

High voltage capacitor should always be discharged by shorting a terminal to a chassis ground. The capacitor has a internal "shunt" resistor, but the mechanical discharge should always be performed to avoid personal injury.

High Voltage Capacitor Removal

- Disconnect power to unit and remove outer case, see "Outer Case" procedure.
- Discharge high voltage capacitor by connecting a jumper wire to the terminal of high voltage capacitor with the diode connected to it. Connect the other end of the jumper wire to a well insulated screwdriver and touch a chassis ground screw located close.
- Remove screws securing capacitor bracket.
- Slide capacitor mounting bracket out of the slots and pull outward on capacitor, diode and bracket.
- Reassemble in reverse order.

Diode

The diode is located next to the high voltage capacitor.

- Disconnect power to unit and remove outer case, see "Outer Case" procedure.
- Discharge high voltage capacitor, see "High Voltage Capacitor" procedure.
- Disconnect diode wire terminal from high voltage capacitor and remove screw securing diode to ground.
- Reassemble in reverse order.

Disassembly Procedures



WARNING

To avoid the risk of electrical shock, personal injury or death; disconnect power to oven and discharge capacitors before following any disassembly procedure.

Transformer

Power Transformer Removal

1. Disconnect power to unit and remove outer case, see "Outer Case" procedure.
2. Discharge high voltage capacitor, see "High Voltage Capacitor" procedure.
3. Disconnect and label wire leads from transformer.
4. Remove screws securing transformer and remove.
5. Reassemble in reverse order.

Fuse

Fuse Removal

Fuse is located in line with the power cord.

1. Disconnect power to unit and remove outer case, see "Outer Case" procedure.
2. Remove and replace fuse, reassemble in reverse order.



CAUTION

Before replacing a blown monitor fuse, test the primary interlock switch, secondary interlock switch, monitor switch, and power relay contacts for proper operation. If the monitor fuse is blown by a failed switch operation all switches and printed circuit board must be replaced.

Magnetron

Magnetron is mounted on the side of the cavity.

1. Disconnect power to unit and and remove outer case, see "Outer Case" procedure.
2. Discharge high voltage capacitor, see "High Voltage Capacitor" procedure.
3. Remove screws securing magnetron to the wave guide.

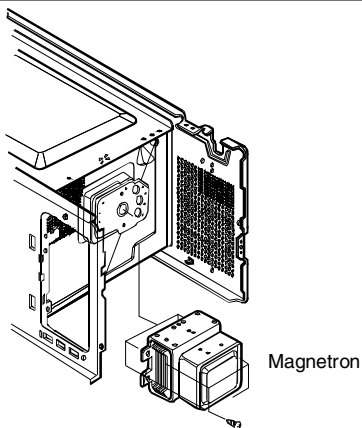

All models except UMC1061*

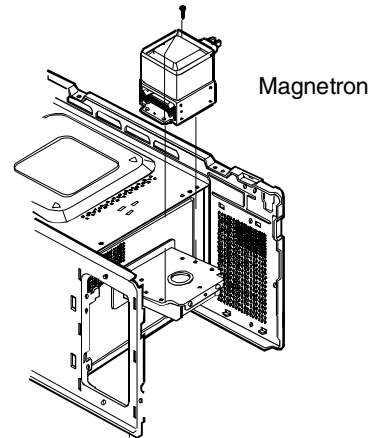

For model UMC1061* only

4. Reassemble in reverse order.

NOTE: When replacing the magnetron, make sure the gasket is in the correct position and in good condition.



CAUTION

During replacement of magnetron, be certain the R.F. anode gasket is in place around the anode stud.



WARNING

A microwave leakage test must be performed anytime a magnetron assembly is removed, replaced, disassembled, or adjusted for any reason.

Suction Guide / Fan Motor Assembly

Suction guide assembly also consists of the latch board assembly.

Magnetron fan motor provides cool air circulation from an external air source, which provides direct cool air through air vanes surrounding the magnetron.

1. Disconnect power to unit and and remove outer case, see "Outer Case" procedure.
2. Discharge high voltage capacitor, see "High Voltage Capacitor" procedure.
3. Disconnect wire leads from fan motor and high voltage capacitor.
4. Remove screw securing diode to chassis.
5. Remove screws securing suction guide assembly to the oven cavity.

Disassembly Procedures



To avoid the risk of electrical shock, personal injury or death; disconnect power to oven and discharge capacitors before following any disassembly procedure.

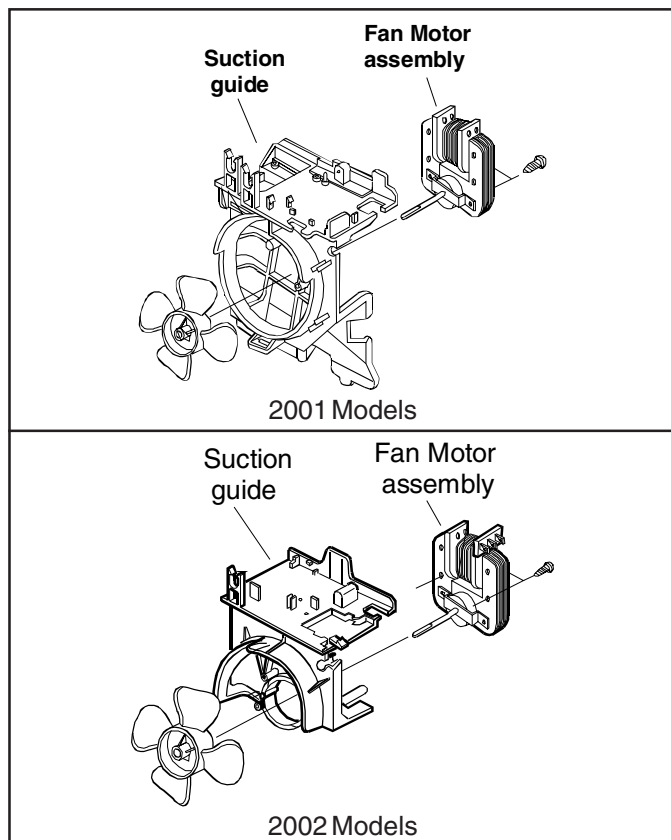

6. Remove screws securing fan motor assembly to suction guide.
7. Reassemble in reverse order.

Humidity Sensor – ACM1460A* and ACM2160A*

The sensor is a plug-in device located on the sensor guide.

1. Disconnect power to unit and remove outer case, see "Outer Case" procedure.
2. Remove screws securing sensor to sensor guide.
3. Disconnect wire terminal plug and replace with new sensor.
4. Reassemble in reverse order.

Oven Thermostat

The oven thermostat is located on the top right side of the oven cavity.

Thermostat is a resettable thermostat.

1. Disconnect power to unit and remove outer case, see "Outer Case" procedure.
2. Disconnect wires from oven thermostat and replace thermostat.
3. Remove screws securing oven thermostat.
4. Reassemble in reverse order.

Light Socket

1. Disconnect power to unit and remove outer case, see "Outer Case" procedure.
2. Disconnect wire terminal plug from light socket.
3. Remove light socket from air duct.
4. Remove light bulb.
5. Replace and reassemble in reverse order.

Turntable Motor

1. Disconnect power to oven.
2. Open the oven door, remove turntable, and gently pry upward on turntable shaft.

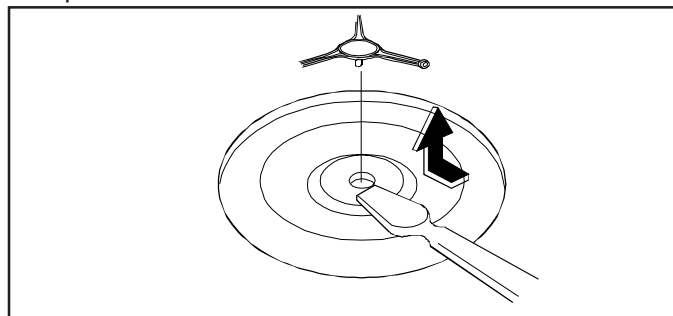

3. Remove bottom plate cover by cutting metal tabs. When reinstalling use screw provided.
4. Disconnect wire leads from turntable motor.

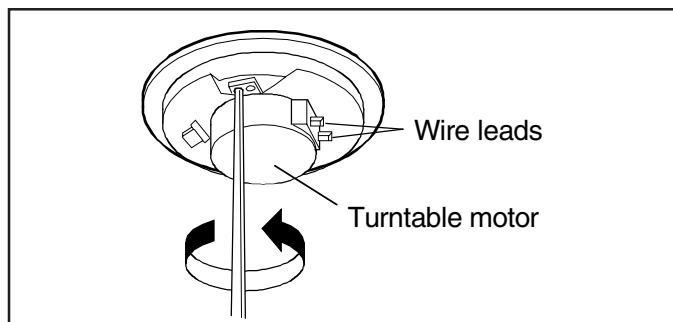

5. Remove screws securing turntable to the oven cavity.
6. Replace and reassemble in reverse order.

Noise Filter

1. Disconnect power to unit and remove outer case, see "Outer Case" procedure.
2. Remove screws securing noise filter to chassis.
3. Disconnect wire terminal plug and replace with new filter.
4. Reassemble in reverse order.

Wiring Diagram and Schematic



WARNING

To avoid the risk of electrical shock, personal injury or death; disconnect power to oven and discharge capacitors before following any disassembly procedure.

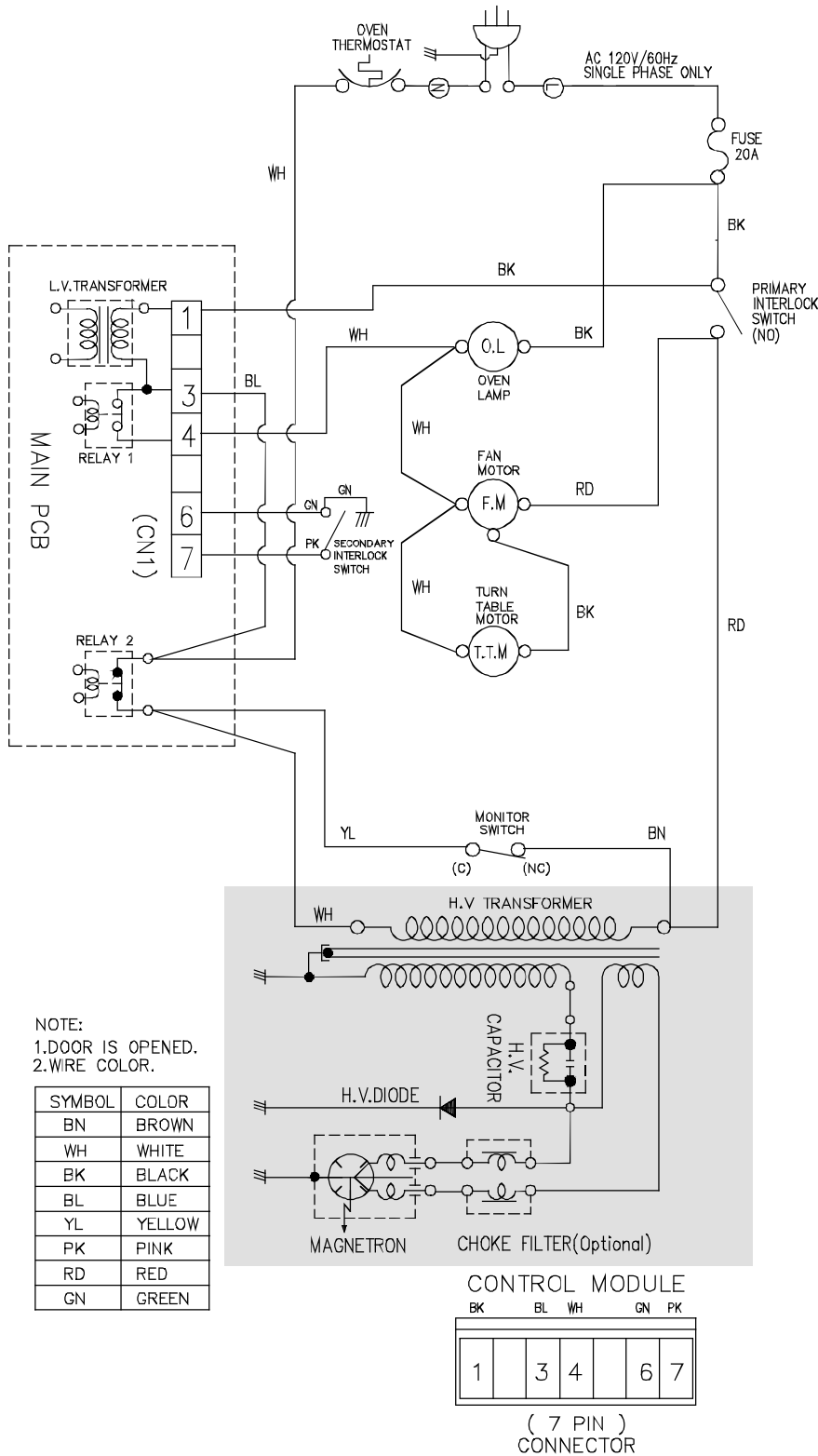

IMPORTANT SAFETY NOTE: THE SHADED AREAS ON THIS SCHEMATIC DIAGRAM INCORPORATE SPECIAL FEATURES IMPORTANT FOR PROTECTION FROM MICROWAVE RADIATION, FIRE, ELECTRICAL SHOCK, AND HAZARDS. WHEN SERVICING IT IS ESSENTIAL THAT ONLY MANUFACTURE'S SPECIFIED PARTS BE USED FOR THE CRITICAL COMPONENTS IN THE SHADED AREAS OF THE SCHEMATIC DIAGRAM.

NOTICE: SINCE THIS IS BASIC SCHEMATIC DIAGRAM, THE VALUES OF COMPONENTS AND SOME PARTIAL CONNECTIONS ARE SUBJECT TO CHANGE FOR IMPROVEMENT.

ACM0720A*

Wiring Diagram and Schematic

WARNING To avoid the risk of electrical shock, personal injury or death; disconnect power to oven and discharge capacitors before following any disassembly procedure.

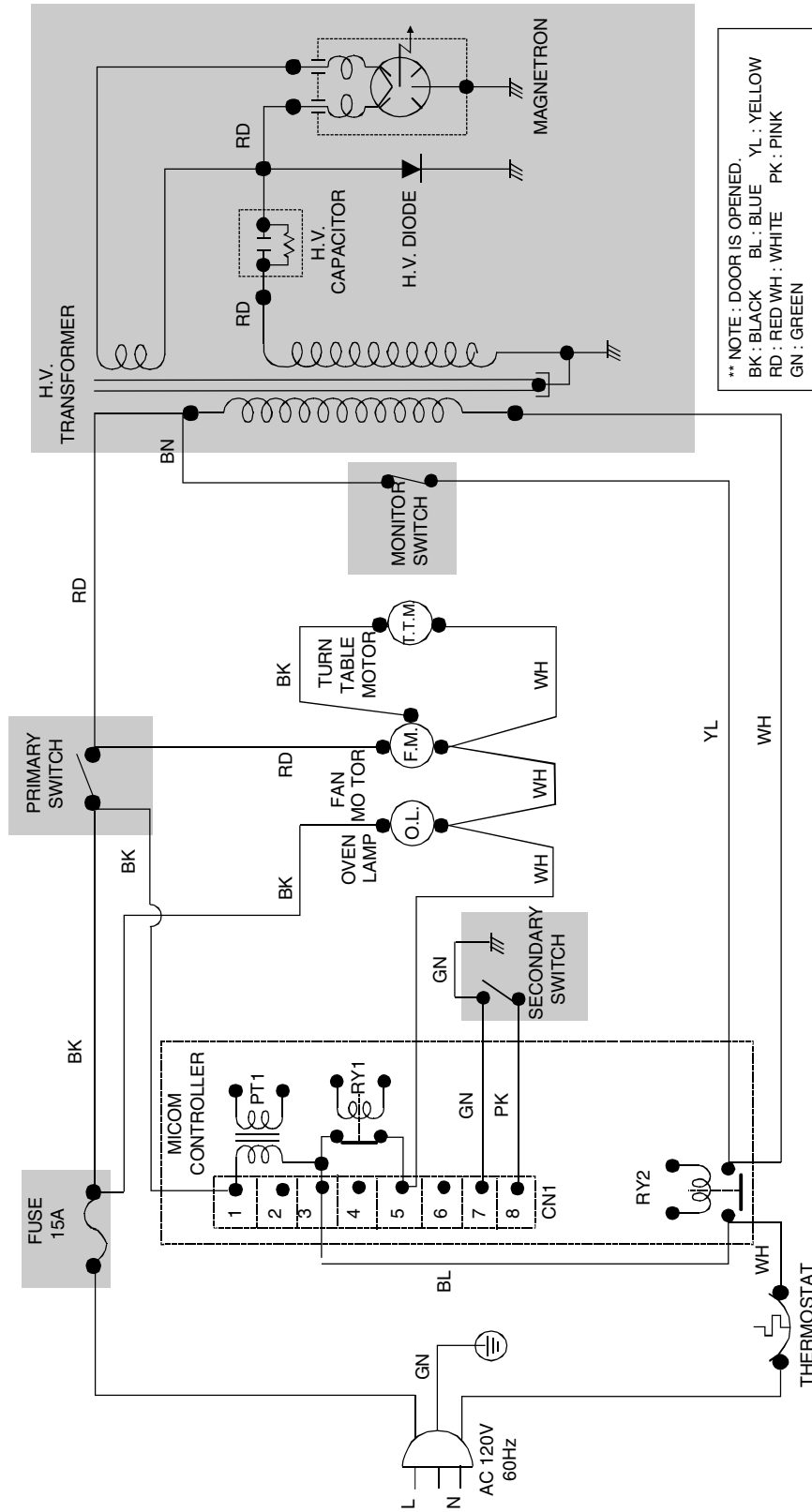

IMPORTANT SAFETY NOTE: THE SHADED AREAS ON THIS SCHEMATIC DIAGRAM INCORPORATE SPECIAL FEATURES IMPORTANT FOR PROTECTION FROM MICROWAVE RADIATION, FIRE, ELECTRICAL SHOCK, AND HAZARDS. WHEN SERVICING IT IS ESSENTIAL THAT ONLY MANUFACTURER'S SPECIFIED PARTS BE USED FOR THE CRITICAL COMPONENTS IN THE SHADED AREAS OF THE SCHEMATIC DIAGRAM.

NOTICE: SINCE THIS IS BASIC SCHEMATIC DIAGRAM, THE VALUES OF COMPONENTS AND SOME PARTIAL CONNECTIONS ARE SUBJECT TO CHANGE FOR IMPROVEMENT.

ACM0860A* and MMC5086A*

Wiring Diagram and Schematic



WARNING

To avoid the risk of electrical shock, personal injury or death; disconnect power to oven and discharge capacitors before following any disassembly procedure.

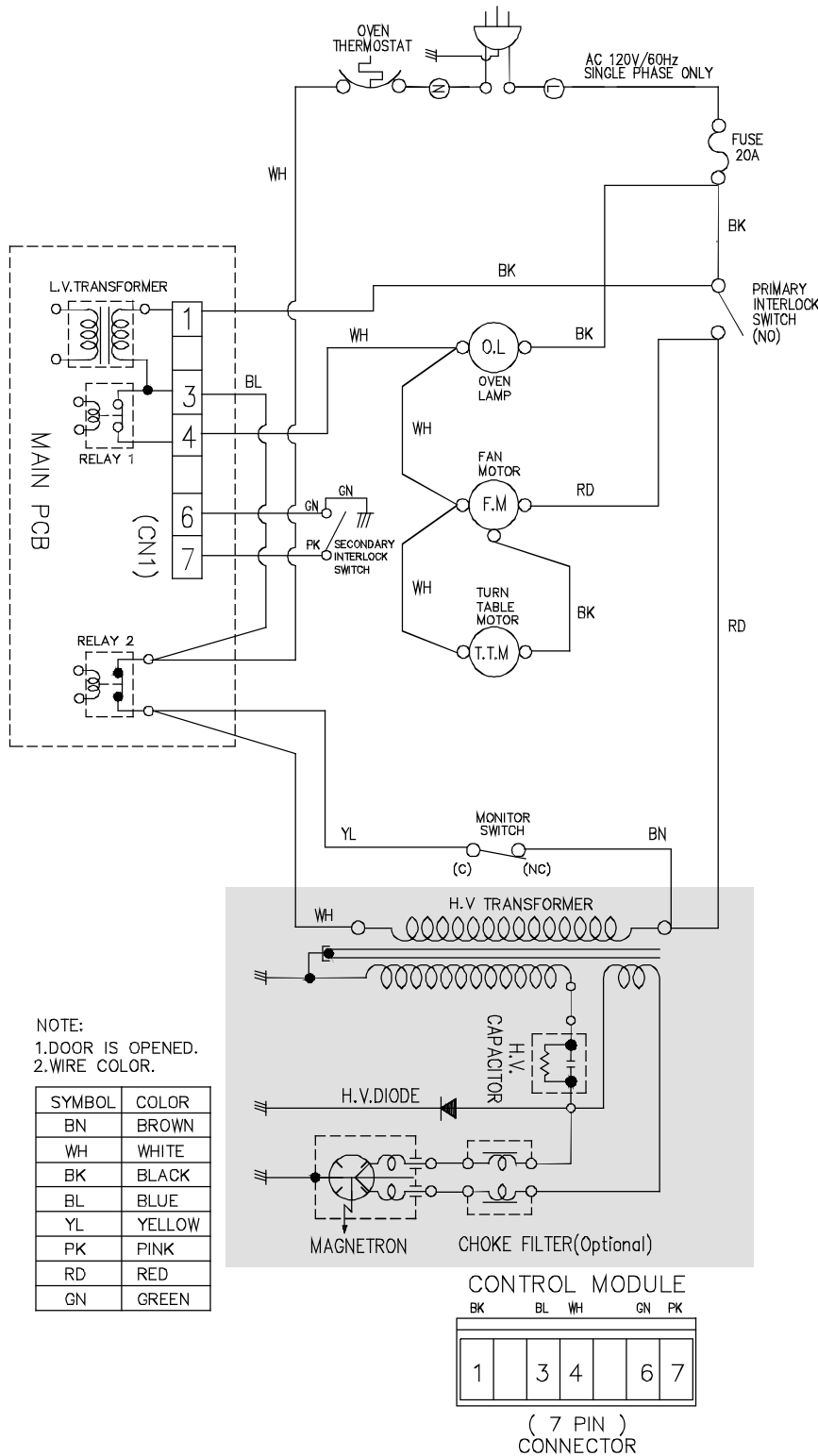

IMPORTANT SAFETY NOTE: THE SHADED AREAS ON THIS SCHEMATIC DIAGRAM INCORPORATE SPECIAL FEATURES IMPORTANT FOR PROTECTION FROM MICROWAVE RADIATION, FIRE, ELECTRICAL SHOCK, AND HAZARDS. WHEN SERVICING IT IS ESSENTIAL THAT ONLY MANUFACTURER'S SPECIFIED PARTS BE USED FOR THE CRITICAL COMPONENTS IN THE SHADED AREAS OF THE SCHEMATIC DIAGRAM.

NOTICE: SINCE THIS IS BASIC SCHEMATIC DIAGRAM, THE VALUES OF COMPONENTS AND SOME PARTIAL CONNECTIONS ARE SUBJECT TO CHANGE FOR IMPROVEMENT.

ACM1120A*

Wiring Diagram and Schematic

WARNING To avoid the risk of electrical shock, personal injury or death; disconnect power to oven and discharge capacitors before following any disassembly procedure.

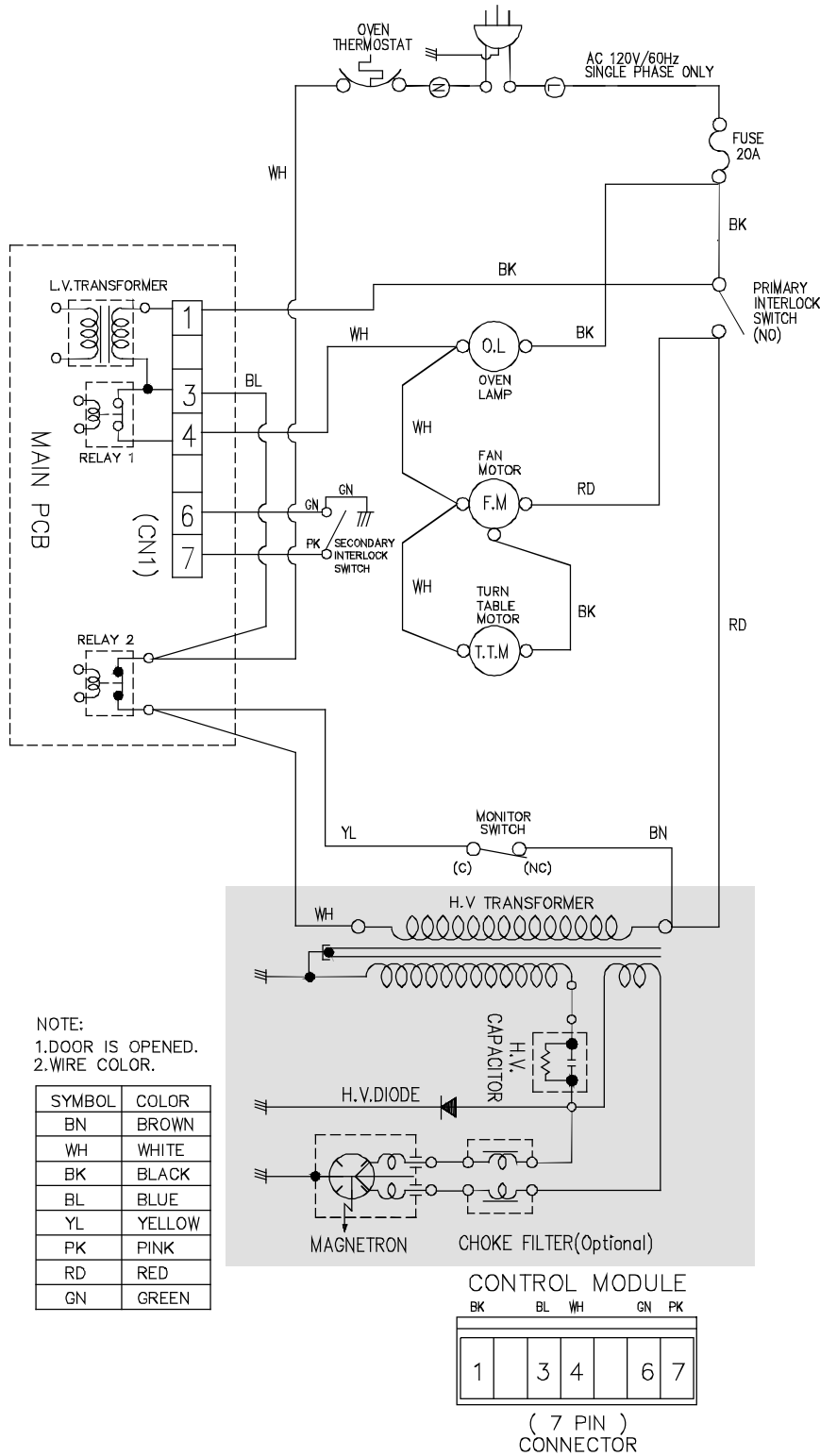

IMPORTANT SAFETY NOTE: THE SHADED AREAS ON THIS SCHEMATIC DIAGRAM INCORPORATE SPECIAL FEATURES IMPORTANT FOR PROTECTION FROM MICROWAVE RADIATION, FIRE, ELECTRICAL SHOCK, AND HAZARDS. WHEN SERVICING IT IS ESSENTIAL THAT ONLY MANUFACTURE'S SPECIFIED PARTS BE USED FOR THE CRITICAL COMPONENTS IN THE SHADED AREAS OF THE SCHEMATIC DIAGRAM.

NOTICE: SINCE THIS IS BASIC SCHEMATIC DIAGRAM, THE VALUES OF COMPONENTS AND SOME PARTIAL CONNECTIONS ARE SUBJECT TO CHANGE FOR IMPROVEMENT.

ACM1420A*

Wiring Diagram and Schematic



WARNING

To avoid the risk of electrical shock, personal injury or death; disconnect power to oven and discharge capacitors before following any disassembly procedure.

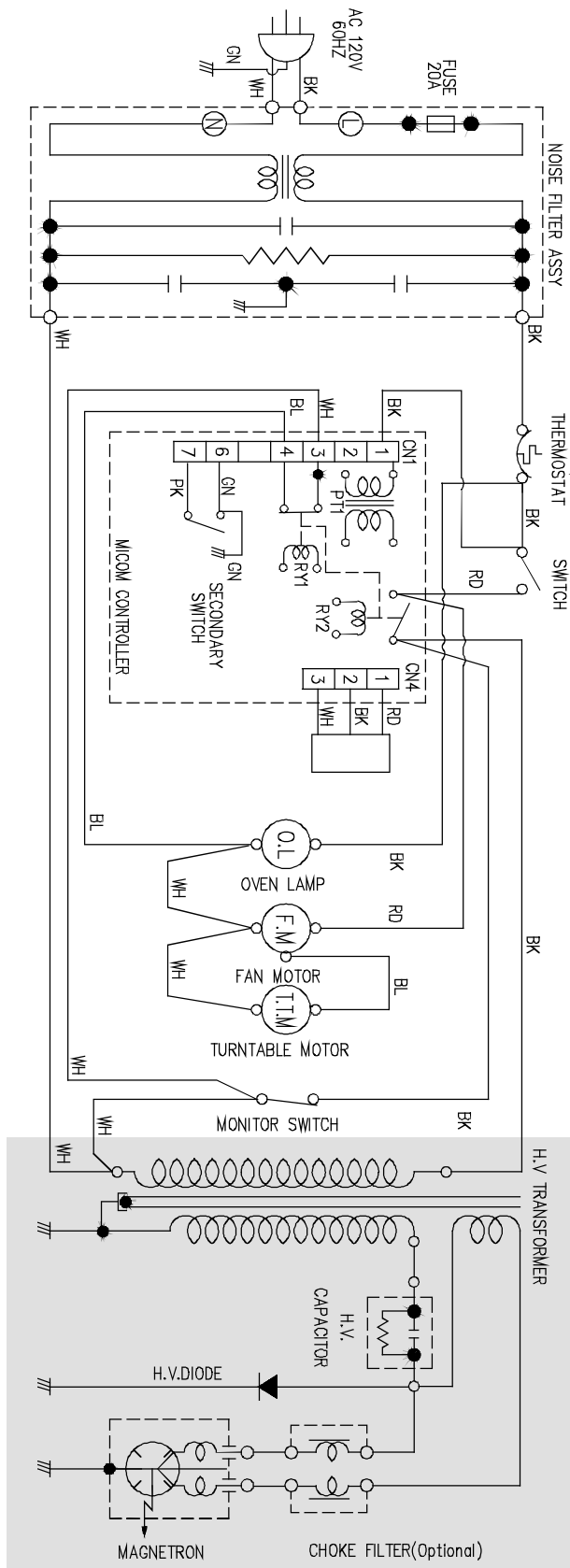

* NOTE : DOOR IS OPENED.

BK: BLACK RD: RED YL: YELLOW
 WH: WHITE PK: PINK BN: BROWN
 BL: BLUE GN: GREEN

IMPORTANT SAFETY NOTE: THE SHADED AREAS ON THIS SCHEMATIC DIAGRAM INCORPORATE SPECIAL FEATURES IMPORTANT FOR PROTECTION FROM MICROWAVE RADIATION, FIRE, ELECTRICAL SHOCK, AND HAZARDS. WHEN SERVICING IT IS ESSENTIAL THAT ONLY MANUFACTURE'S SPECIFIED PARTS BE USED FOR THE CRITICAL COMPONENTS IN THE SHADED AREAS OF THE SCHEMATIC DIAGRAM.

NOTICE: SINCE THIS IS BASIC SCHEMATIC DIAGRAM, THE VALUES OF COMPONENTS AND SOME PARTIAL CONNECTIONS ARE SUBJECT TO CHANGE FOR IMPROVEMENT.

ACM 2160A* (Series 50) and ACM1460A*

Wiring Diagram and Schematic



To avoid the risk of electrical shock, personal injury or death; disconnect power to oven and discharge capacitors before following any disassembly procedure.

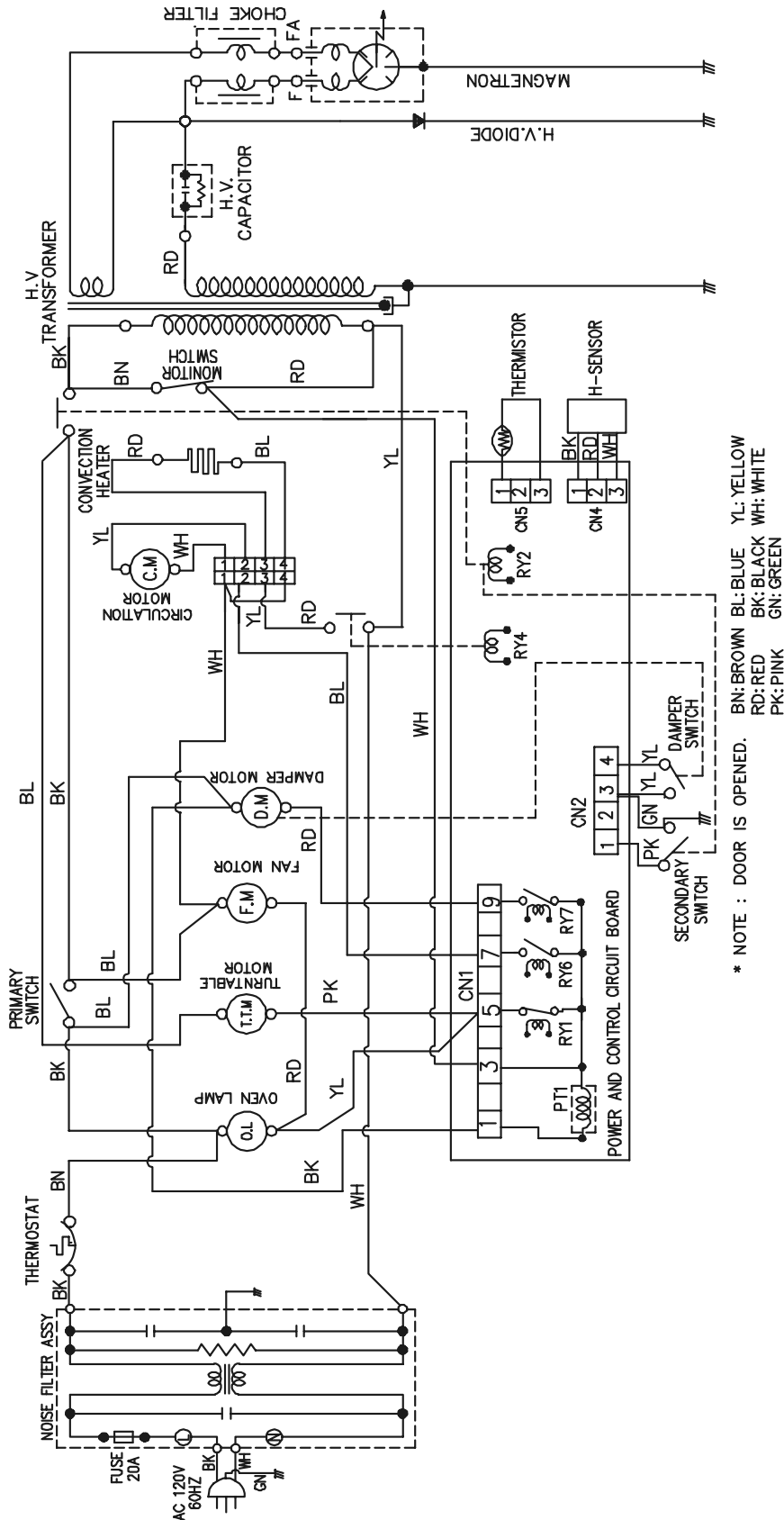

IMPORTANT SAFETY NOTE: THE SHADED AREAS ON THIS SCHEMATIC DIAGRAM INCORPORATE SPECIAL FEATURES IMPORTANT FOR PROTECTION FROM MICROWAVE RADIATION, FIRE, ELECTRICAL SHOCK, AND HAZARDS. WHEN SERVICING IT IS ESSENTIAL THAT ONLY MANUFACTURER'S SPECIFIED PARTS BE USED FOR THE CRITICAL COMPONENTS IN THE SHADED AREAS OF THE SCHEMATIC DIAGRAM.

NOTICE: SINCE THIS IS BASIC SCHEMATIC DIAGRAM, THE VALUES OF COMPONENTS AND SOME PARTIAL CONNECTIONS ARE SUBJECT TO CHANGE FOR IMPROVEMENT.

ACM 2160A* (Series 51)

Wiring Diagram and Schematic



WARNING

To avoid the risk of electrical shock, personal injury or death; disconnect power to oven and discharge capacitors before following any disassembly procedure.

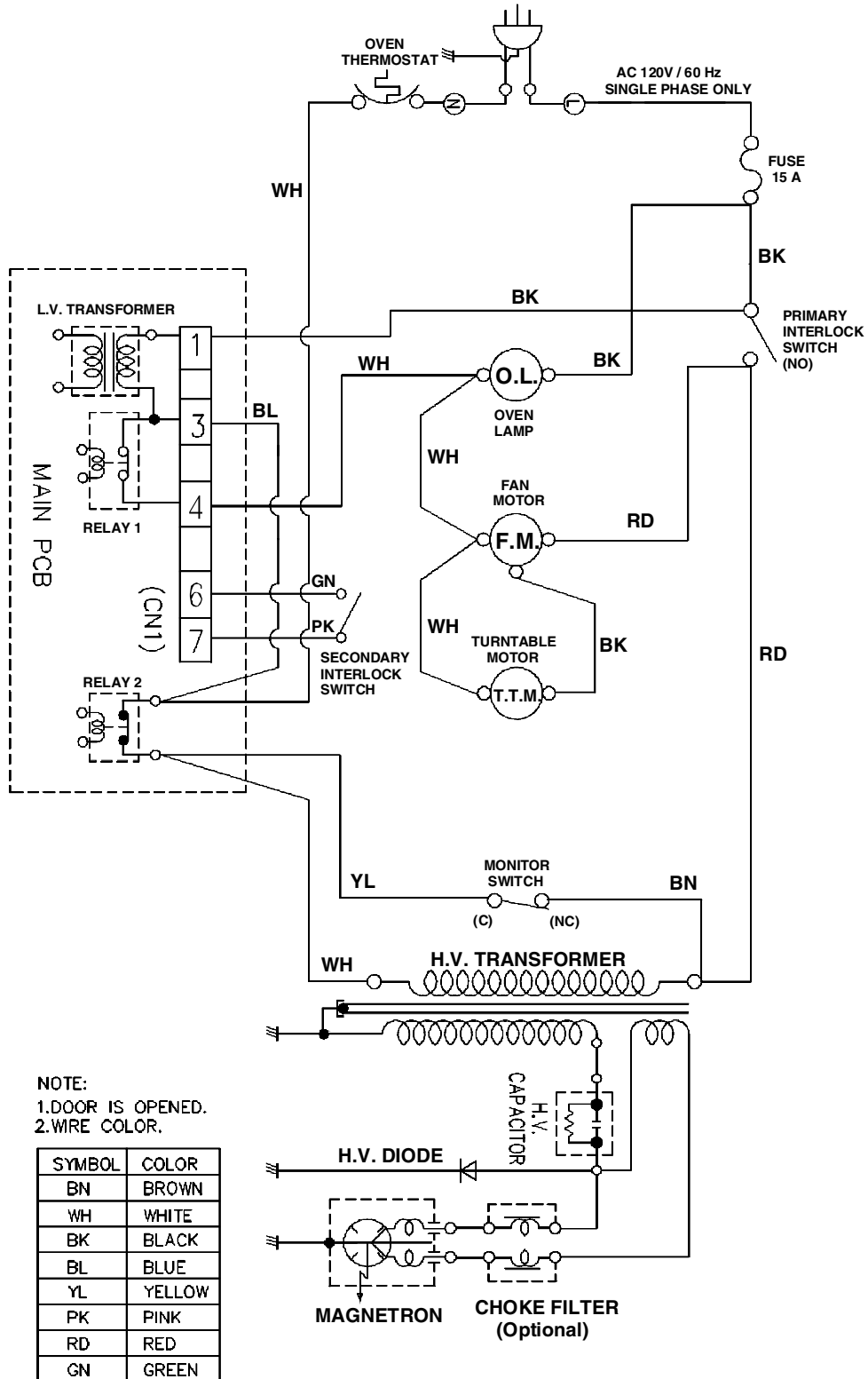

IMPORTANT SAFETY NOTE: THE SHADED AREAS ON THIS SCHEMATIC DIAGRAM INCORPORATE SPECIAL FEATURES IMPORTANT FOR PROTECTION FROM MICROWAVE RADIATION, FIRE, ELECTRICAL SHOCK, AND HAZARDS. WHEN SERVICING IT IS ESSENTIAL THAT ONLY MANUFACTURER'S SPECIFIED PARTS BE USED FOR THE CRITICAL COMPONENTS IN THE SHADED AREAS OF THE SCHEMATIC DIAGRAM.

NOTICE: SINCE THIS IS BASIC SCHEMATIC DIAGRAM, THE VALUES OF COMPONENTS AND SOME PARTIAL CONNECTIONS ARE SUBJECT TO CHANGE FOR IMPROVEMENT.

UMC1061A*

Appendix A

Installation Instructions



WARNING

To avoid risk of electrical shock or death, this oven must be earthed.

To avoid risk of electrical shock or death, do not alter the plug.

GROUNDING INSTRUCTIONS

This appliance must be grounded. In the event of an electrical short circuit, grounding reduces the risk of electric shock by providing an escape wire for the electric current. This appliance is equipped with a cord having a grounding wire with a grounding plug. The plug must be plugged into an outlet that is properly installed and grounded.

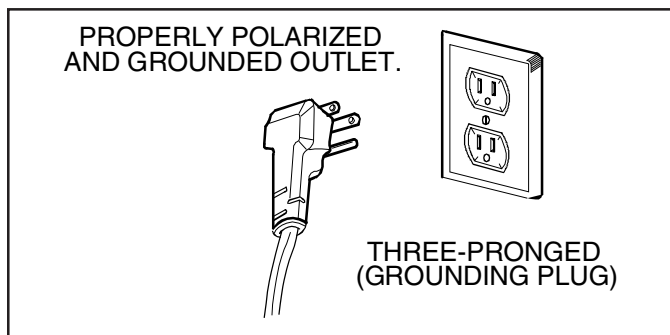

CIRCUITS

For safety purposes this oven must be plugged into a 15 or 20 Amp circuit. No other electrical appliances or lighting circuits should be on this line. If in doubt, consult a licensed electrician.

VOLTAGE

The voltage used at the wall receptacle must be the same as specified on the oven name plate located inside oven door. Use of a higher voltage is dangerous and may result in a fire or other type of accident causing oven damage. Low voltage will cause slow cooking. In case your microwave oven does not perform normally in spite of proper voltage, remove and reinsert the plug.

Your microwave oven can be placed easily in your kitchen, family room, or anywhere else in your home. Place the oven on a flat surface such as a kitchen countertop or a specially designed microwave oven cart. Do not place oven above a gas or electric range. Free air flow around the oven is important.

DO NOT BLOCK AIR VENTS

All air vents should be kept clear during cooking. If air vents are covered during oven operation the oven may overheat. In this case, a sensitive thermal safety device automatically turns the oven off. The oven will be inoperable until it has cooled sufficiently.

RADIO INTERFERENCE

1. Microwave oven operation may interfere with TV or radio reception.
2. When there is interference, it may be reduced or eliminated by taking the following measures:
 - a. Clean the door and the sealing surfaces of the oven.
 - b. Reorient the receiving antenna of radio or television.
 - c. Relocate the microwave oven in relation to the TV or radio.
 - d. Move the microwave oven away from the receiver.
 - e. Plug the microwave oven into a different outlet so that microwave oven and receiver are on different branch circuits.

UNPACKING OVEN

- Inspect oven for damage such as dents in door or inside oven cavity.
- Report any dents or breakage to source of purchase immediately.

Do not attempt to use oven if damaged.

- Remove all materials from oven interior.
- If oven has been stored in extremely cold area, wait a few hours before connecting power.

Appendix B

Programming Instructions for ACM0720A* and UCM1061A*

Control Panel

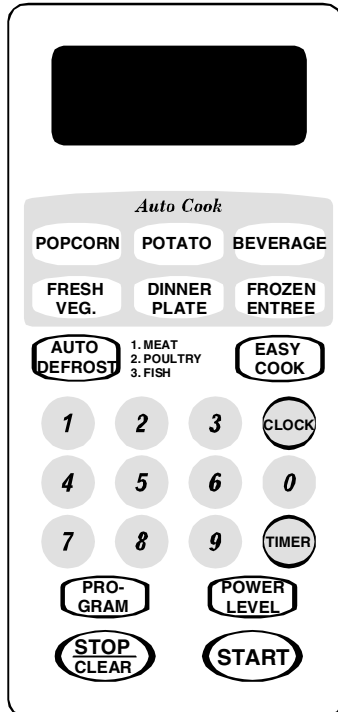

ACM0720A*

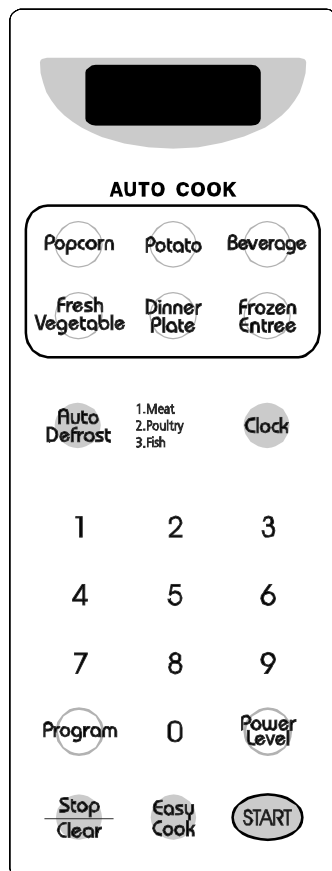

ACM1061A*

Setting Clock

This is a 12 hour clock. When your oven is plugged in for the first time or when power resumes after a power interruption, the numbers in the display reset to 0.

1. Press **CLOCK** pad.
2. Enter desired time by using the number key pads.
3. Press **CLOCK** pad.
 - The clock starts.

Timer

You can use the **TIMER** of your oven for purposes other than food cooking.

1. Press **TIMER** pad.
2. Enter desired time, by using number key pads.
3. Press **START** pad.

Easy Cook

A time-saving pad, this simplified control lets you quickly set and start microwave cooking without the need to press the **START** pad.

- Press **EASY COOK** pad.
 - The oven begins cooking and displays starts counting down.

NOTE: If **EASY COOK** pad is pressed, 30 seconds will be added up to 3 minutes.

After 3 minutes, every time **EASY COOK** pad is pressed, 1 minute will be added up to 99 minutes 59 seconds.

Time Cook

This function allows food to cook for a desired time, and in order to give you the best results. There are 10 power level settings in addition to **HI-POWER**, because many foods need slower cooking (at less than **HI-POWER**).

1. Enter desired time, by using number key pads.
2. Press **POWER LEVEL** pad.
 - **P-HI** appears in the display. This indicates that the oven is set on **HI**, unless a different power setting is chosen.
3. Press a number pad indicating the desired power level.
 - Display shows **P-XX**, indicating the percentage of power being used.
4. Press **START** pad.
 - When the cooking time is over, two short and one long tone sounds. The word "End" is indicated in the display window. Then the oven shuts itself off.

NOTE: If you do not select the power level, the oven will operate at power **HIGH**. To set **HI-POWER** cooking, skip steps 2 & 3 above.

Programming Instructions for ACM0720A* and UCM1061A*

Multi-Stage Time Cook

This feature allows multiple stage cooking.

1. Press **PROGRAM** pad.
2. Repeat **TIME COOK** steps 1 - 3.
3. Press **START** pad.

NOTE: Auto Defrost can be programmed before the first stage to defrost first and then perform cooking.

Child Lock

This is an unique safety feature locks out the control panel preventing all oven operations.

1. Press **STOP/CLEAR** pad.
2. Press and hold **0**, until "L" appears in the display and two beeps has sounded.

NOTE: Once child lock has been engaged, "L" will appear in the display if any cooking function is pressed.

- Perform procedure again to deactivate the child lock.

Auto Cook

The internal oven menu has 6 preprogrammed cooking functions to cook food automatically.

- Read and follow the chart below to perform a cooking function.

Pad	Press	Serving size
POPCORN	One time.....	3.5 oz.
	Two times.....	3.0 oz.
	Three Times.....	1.75 oz.
POTATO	One time.....	1
	Two times.....	2
	Three times.....	3
	Four times.....	4
BEVERAGE	One time.....	1 cup
	Two times.....	2 cups
FRESH VEGETABLE	One time.....	1 cup
	Two times.....	2 cups
	Three times.....	3 cups
	Four times.....	4 cups
DINNER PLATE	One time.....	1 serving
	Two times.....	2 servings
FROZEN ENTRÉE	One time.....	10 oz.

Auto Defrost

This feature has three different defrost levels that will automatically set the defrost time and power level according to the weight of the food.

For added convenience, this cycle includes a built-in beep mechanism that reminds you to check, turn over, separate or rearrange the food.

1. Press **AUTO DEFROST** pad, see chart below to determine the type of defrost cycle preferred.

Pad	Sequence	Food
Press AUTO DEFROST pad one time	dEF1 MEAT	BEEF Ground beef, Round steak, Cubes for stew, Tenderlion steak, Pot roast, Rib roast, Rump roast, Chuck roast, Hamburger patty LAMB Chop (1 inch thick), Rolled roast PORK Chop (1/2 inch thick), Hot dogs, Spareribs, Country-style ribs, Rolled roast, Sausage VEAL Cutlets (1 lb. 1/2 inch thick)
Press AUTO DEFROST pad two times	dEF2 POULTRY	POULTRY Whole (under 4 lbs.), Cut up breast (boneless) CORNISH HENS Whole TURKEY Breast (under 6 lbs.)
Press AUTO DEFROST pad three times	dEF3 FISH	FISH Fillets, Whole steaks SHELLFISH Crab meat, Lobster tails, Shrimp, Scallops

2. Enter weight of the food.
3. Press **START** pad.
 - Once the **START** pad is pressed the display changes top the defrost count down.

NOTE: The oven **will not stop** during the BEEP unless the oven door is opened.

NOTE: Refer to OWNER'S manual for complete instructions on COOKING CHARTS.

Programming Instructions for ACM1120A* and ACM1420A*

Control Panel

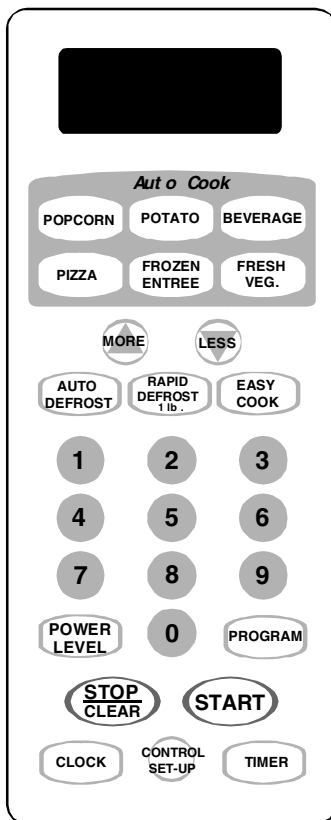

ACM1120A* and ACM1420A*

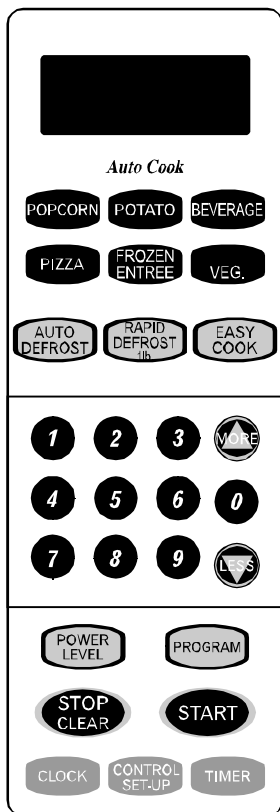

2002 ACM1120A*

SETTING CLOCK

This is a 12 hour clock. When your oven is plugged in for the first time or when power resumes after a power interruption, the numbers in the display reset to 0.

1. Press **CLOCK** pad.
 - Display scrolls the words "ENTER TIME OF DAY".
2. Enter desired time by using the number key pads.
3. Press **START** pad.
 - The clock starts.

TIMER

You can use the **TIMER** of your oven for purposes other than food cooking.

1. Press **TIMER** pad.
 - Display scrolls the words "ENTER TIME IN MIN AND SEC".
2. Enter desired time, by using number key pads.
3. Press **START** pad.

EASY COOK

A time-saving pad, this simplified control lets you quickly set and start microwave cooking without the need to press the **START** pad.

- Press **EASY COOK** pad.
 - The oven begins cooking and displays starts counting down.

NOTE: If **EASY COOK** pad is pressed, 30 seconds will be added up to 3 minutes. After 3 minutes, every time **EASY COOK** pad is pressed, 1 minute will be added up to 99 minutes 59 seconds.

TIME COOK

This function allows food to cook for a desired time, and in order to give you the best results. There are 10 power level settings in addition to HI-POWER, because many foods need slower cooking (at less than HI-POWER).

1. Enter desired time, by using number key pads.
2. Press **POWER LEVEL** pad.
 - P-HI appears in the display. This indicates that the oven is set on HI, unless a different power setting is chosen.
3. Press a number pad indicating the desired power level.
 - Display shows **P-XX**, indicating the percentage of power being used.
4. Press **START** pad.
 - When the cooking time is over, two short and one long tone sounds. The word "End" is indicated in the display window. Then the oven shuts itself off.

NOTE: If you do not select the power level, the oven will operate at power HIGH. To set HI-POWER cooking, skip steps 2 & 3 above.

Programming Instructions for ACM1120A* and ACM1420A*

Multi-Stage Time Cook

This feature allows four multiple stage cooking.

1. Press **PROGRAM** pad.
2. Repeat **TIME COOK** steps 1 - 3.
3. Press **START** pad.

NOTE: Auto Defrost can be programmed before the first stage to defrost first and then perform cooking.

Child Lock

This is an unique safety feature locks out the control panel preventing all oven operations.

1. Press **STOP/CLEAR** pad.
2. Press and hold **0**, until "LOCKED" appears in the display and two beeps has sounded.

NOTE: Once child lock has been engaged, "LOCKED" will appear in the display if any cooking function is pressed.

- Perform procedure again to deactivate the child lock.

Auto Cook

The internal oven menu has 6 preprogrammed cooking functions to cook food automatically.

- Read and follow the chart below to perform a cooking function.

Pad	Press number pad	Serving size
POPCORN	1	1.75 oz.
	2	3.0 oz.
	3	3.5 oz.
POTATO	1	1 (8 oz.)
	2	2 (16 oz.)
	3	3 (24 oz.)
	4	4 (32 oz.)
BEVERAGE	1	1 cup
	2	2 cups
PIZZA	1	1 slice (5 oz.)
	2	2 slices (10 oz.)
	3	3 slices (15 oz.)
FROZEN ENTRÉE	1	10 oz.
FRESH VEGETABLE	1	1 cup
	2	2 cups
	3	3 cups
	4	4 cups

Control Set-Up

This function provides five different modes that can be changed.

1. Press **CONTROL SET-UP** pad.
2. Press the number pad identifying with the first column in the chart below.

Number pad	Function	Option
1	Sound ON	1
	Sound OFF.....	2
2	Clock ON.....	1
	Clock OFF.....	2
3	Scroll speed	1 Slow
		2 Normal
		3 Fast
4	Weight.....	1 lbs.
		2 Kg.
5	Demo ON	1
	Demo OFF	2

3. Press the option number pad identifying with the function desired.

NOTE: The default settings are Sound ON, Clock ON, Normal Speed, LBS, and Demo OFF.

NOTE: Demo mode allows the oven to operate without oven heating functions.

More / Less

This feature allows all of the **AUTO COOK, TIME COOK, EASY COOK,** and **RAPID DEFROST** programs to be adjusted for a longer or shorter cooking time.

1. Perform one of the cooking programs listed above.
2. Before pressing the **START** pad.
 - Pressing **MORE** pad will add 10 seconds of cooking time each time it is pressed.
 - Pressing **LESS** pad will subtract 10 seconds of cooking time each time it is pressed.

Rapid Defrost

This feature allows quick defrosting for 1.0 lb. of frozen food.

- Press **RAPID DEFROST** pad.
- Oven begins to defrost the food.

Programming Instructions for ACM1120A* and ACM1420A*

Auto Defrost

This feature has three different defrost levels that will automatically set the defrost time and power level according to the weight of the food.

For added convenience, this cycle includes a built-in beep mechanism that reminds you to check, turn over, separate or rearrange the food.

1. Press **AUTO DEFROST** pad, see chart below to determine the type of defrost cycle preferred.

2. Enter weight of the food.
3. Press **START** pad.
 - Once the **START** pad is pressed the display changes to the defrost count down.

NOTE: The oven **will not stop** during the BEEP unless the oven door is opened.

NOTE: Refer to OWNER'S manual for complete instructions on COOKING CHARTS.

Pad	Sequence	Food
Press AUTO DEFROST pad one time	dEF1 MEAT	BEEF Ground beef, Round steak, Cubes for stew, Tenderloin steak, Pot roast, Rib roast, Rump roast, Chuck roast, Hamburger patty LAMB Chop (1 inch thick), Rolled roast PORK Chop (1/2 inch thick), Hot dogs, Spareribs, Country-style ribs, Rolled roast, Sausage VEAL Cutlets (1 lb. 1/2 inch thick)
Press AUTO DEFROST pad two times	dEF2 POULTRY	POULTRY Whole (under 4 lbs.), Cut up breast (boneless) CORNISH HENS Whole TURKEY Breast (under 6 lbs.)
Press AUTO DEFROST pad three times	dEF3 FISH	FISH Fillets, Whole steaks SHELLFISH Crab meat, Lobster tails, Shrimp, Scallops

Programming Instructions for ACM1460A* and ACM2160A*

Control Panel

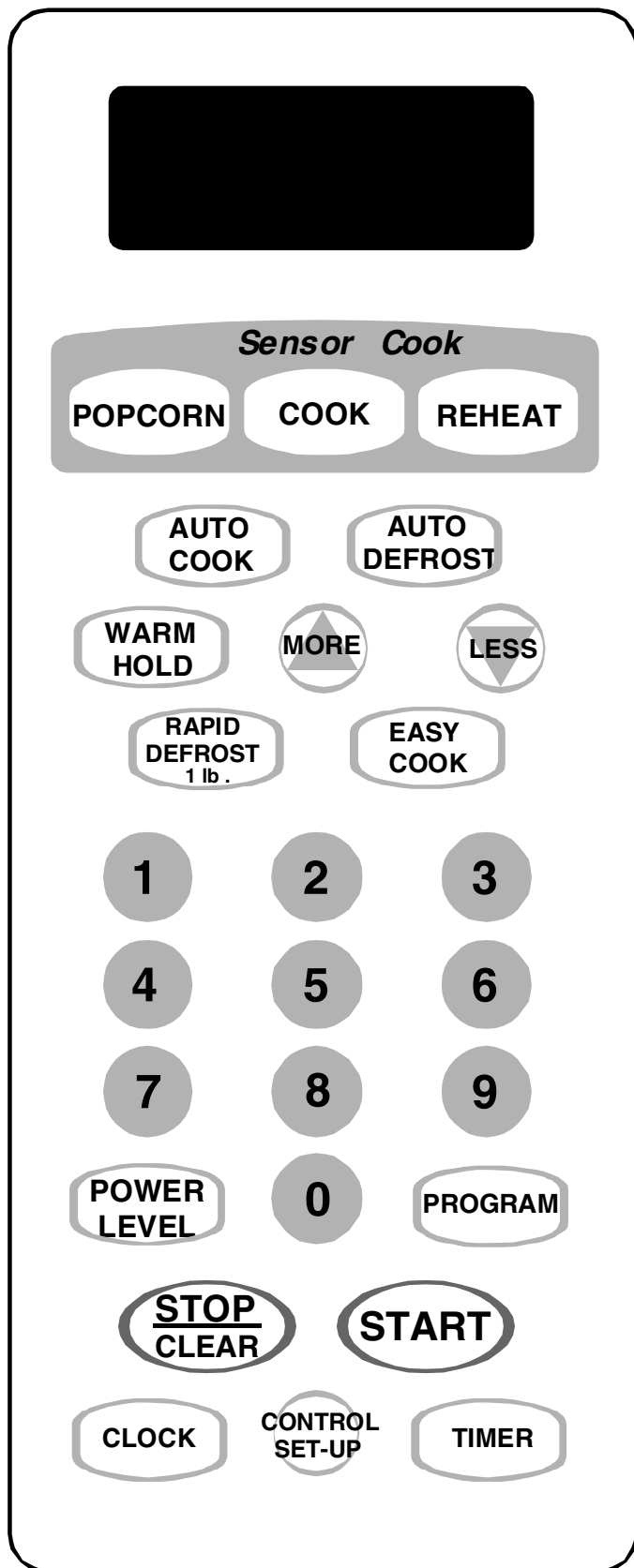

Setting Clock

This is a 24 hour clock. When your oven is plugged in for the first time or when power resumes after a power interruption, the numbers in the display reset to “:”.

1. Press **CLOCK** pad.
 - Press pad once for AM or twice for PM.
2. Enter desired time by using the number key pads.
3. Press **START** pad.
 - The clock starts.

Timer

You can use the TIMER of your oven for purposes other than food cooking.

1. Press **TIMER** pad.
 - Display scrolls the words: “ENTER TIME IN MIN AND SEC”.
2. Enter desired time, by using number key pads.
 - Display scrolls the words: “TOUCH START”.
3. Press **START** pad.

Easy Cook

A time-saving pad, this simplified control lets you quickly set and start microwave cooking without the need to press the **START** pad.

- Press **EASY COOK** pad.
 - The oven begins cooking and displays starts counting down.

NOTE: If **EASY COOK** pad is pressed, 30 seconds will be added up to 3 minutes. After 3 minutes, every time **EASY COOK** pad is pressed, 1 minute will be added up to 99 minutes 59 seconds.

Time Cook

This function allows food to cook for a desired time, and in order to give you the best results. There are 10 power level settings in addition to HI-POWER, because many foods need slower cooking (at less than HI-POWER).

1. Enter desired time, by using number key pads.
 - Display scrolls the words: “TOUCH START OR POWER”.
2. Press **POWER LEVEL** pad.
 - Display scrolls the words: “ENTER POWER LEVEL 1 TO 10”.
3. Press a number pad indicating the desired power level.
 - Display scrolls the words: “P-XX TOUCH START”.
4. Press **START** pad.
 - When the cooking time is over, a beep sounds. The word “END” is indicated in the display window. Then the oven shuts itself off.

NOTE: If you do not select the power level, the oven will operate at power HIGH. To set HI-POWER cooking, skip steps 2 & 3 above.

Programming Instructions for ACM1460A* and ACM2160A*

Multi-Stage Time Cook

This feature allows four multiple stage cooking.

1. Press **PROGRAM** pad.
2. Repeat **TIME COOK** procedure, steps 1 through 3.
3. Press **START** pad.

NOTE: Auto Defrost can be programmed before the first stage to defrost first and then perform cooking.

Child Lock

This is an unique safety feature locks out the control panel preventing all oven operations.

1. Press **STOP/CLEAR** pad.
2. Press and hold **0**, until "LOCKED" appears in the display and two beeps has sounded.

NOTE: Once child lock has been engaged, "LOCKED" will appear in the display if any cooking function is pressed.

- Perform procedure again to deactivate the child lock.

Control Set-Up

This function provides five different modes that can be changed.

1. Press **CONTROL SET-UP** pad.
2. Press the number pad identifying with the first column in the chart below.

Number pad	Function	Option
1	Sound ON Sound OFF.....	1 2
2	Clock ON..... Clock OFF.....	1 2
3	Scroll speed	1Slow 2Normal 3Fast
4	Weight.....	1 lbs. 2 Kg.
5	Demo ON Demo OFF	1 2

3. Press the option number pad identifying with the function desired.

NOTE: The default settings are Sound ON, Clock ON, Normal Speed, LBS, and Demo OFF.

NOTE: Demo mode allows the oven to operate without oven heating functions.

More / Less

This feature allows all of the **AUTO COOK, TIME COOK, EASY COOK**, and **SENSOR COOK** programs to be adjusted for a longer or shorter cooking time.

1. Perform one of the cooking programs listed above.
2. Count down sequence must begin before adding or subtracting time can be performed.
 - Pressing **MORE** pad will add 10 seconds of cooking time each time it is pressed.
 - Pressing **LESS** pad will subtract 10 seconds of cooking time each time it is pressed.

Sensor Cook

This feature detects the amount of vapor build-up while cooking and automatically determines the cooking time for each food item.

- Press **COOK** pad.
 - Display scrolls the words: "SELECT MENU 1 TO 6 -- SEE COOKING GUIDE BEHIND DOOR".
 - Select the number pad that identifies with the type of food being prepared.

Sensor Popcorn

This feature detects the amount of vapor build-up while cooking and automatically determines the cooking time.

- Press **POPCORN** pad.

NOTE: Do not use any popcorn popping devices in this oven with this feature.

Sensor Reheat

This feature reheats precooked food at room or refrigerated temperatures without selecting cooking times or power levels. This feature has three categories.

1. Press **REHEAT** pad.
 - Display scrolls the words: "SELECT MENU 1 TO 3 -- SEE COOKING GUIDE BEHIND DOOR".
2. Select desired category desire by using the chart below.

Code	Category	Amount
1	Dinner plate	Approximately ½ - 1 lb.
2	Soup / Sauce	1 – 4 cups
3	Casserole	2 – 6 servings

Programming Instructions for ACM1460A* and ACM2160A*

Warm Hold

This feature can be used by itself or to automatically follow a cooking cycle.

1. Press **WARM HOLD** pad.
 - Display scrolls the words: "HOLD WARM TOUCH START".
2. Press **START** pad.
 - Display will indicate "WARM" while the oven continues to operate.

NOTE: Allows cooked food to remain warm for up to 99 minutes and 59 seconds.

Auto Cook

The internal oven menu has 6 preprogrammed cooking functions to cook food automatically.

- Press **AUTO COOK** pad.
 - Read and follow the chart below to perform a cooking function.

Menu	Category	Serving size
1	Bacon	2 – 6 slices
2	Frozen Roll/Muffin	1 – 6 pieces (2 – 3 ounces each)
3	Fresh Roll/Muffin	1 – 6 pieces (2 – 3 ounces each)
4	Beverage	1 – 2 cups
5	Chicken Pieces	½ - 2.0 lbs.
6	Hot Cereal	1 – 6 servings

NOTE: Refer to OWNER'S manual for complete cooking instructions.

Rapid Defrost

This feature allows quick defrosting for 1.0 lb. of frozen food.

- Press **RAPID DEFROST** pad.
 - Oven begins to defrost the food.

Auto Defrost

This feature has three different defrost levels that will automatically set the defrost time and power level according to the weight of the food.

For added convenience, this cycle includes a built-in beep mechanism that reminds you to check, turn over, separate or rearrange the food.

1. Press **AUTO DEFROST** pad, see chart below to determine the type of defrost cycle preferred.
 - Display scrolls the words: "MEAT TOUCH 1 POULTRY TOUCH 2 FISH TOUCH 3".
2. Enter number indicating type of food desired.
 - Display scrolls the words: "ENTER WEIGHT".

Pad	Sequence	Food
Press pad number 1	MEAT	BEEF Ground beef, Round steak, Cubes for stew, Tenderlion steak, Pot roast, Rib roast, Rump roast, Chuck roast, Hamburger patty LAMB Chop (1 inch thick), Rolled roast PORK Chop (1/2 inch thick), Hot dogs, Spareribs, Country-style ribs, Rolled roast, Sausage VEAL Cutlets (1 lb. ½ inch thick)
Press pad number 2	POULTRY	POULTRY Whole (under 4 lbs.), Cut up breast (boneless) CORNISH HENS Whole TURKEY Breast (under 6 lbs.)
Press pad number 3	FISH	FISH Fillets, Whole steaks SHELLFISH Crab meat, Lobster tails, Shrimp, Scallops

3. Enter the weight of the food.
 - Available weight is 0.1 to 6.0 lbs.
4. Press **START** pad.

NOTE: The oven **will not stop** during the BEEP unless the oven door is opened.

NOTE: Refer to OWNER'S manual for complete instructions on COOKING CHART.

Programming Instructions for ACM0860A* and MMC5086A*

Control Panel

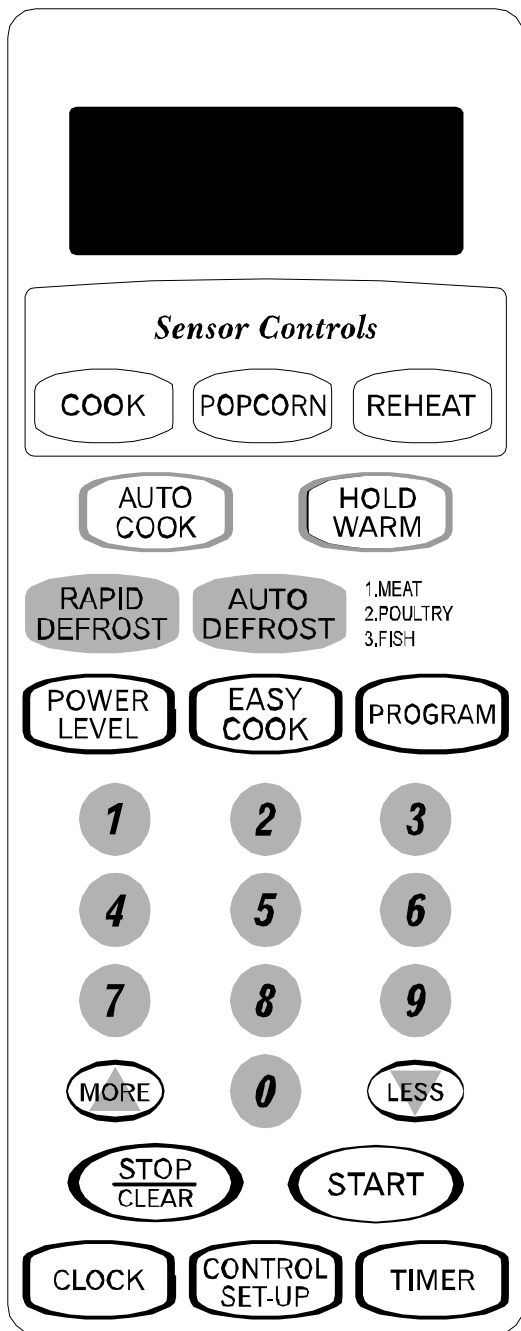

Setting Clock

This is a 12 hour clock. When your oven is plugged in for the first time or when power resumes after a power interruption, the numbers in the display reset to 0.

1. Press **CLOCK** pad.
2. Enter desired time by using the number key pads.
3. Press **CLOCK** pad.
 - The clock starts.

Timer

You can use the TIMER of your oven for purposes other than food cooking.

1. Press **TIMER** pad.
2. Enter desired time, by using number key pads.
3. Press **START** pad.

Easy Cook

A time-saving pad, this simplified control lets you quickly set and start microwave cooking without the need to press the **START** pad.

- Press **EASY COOK** pad.
 - The oven begins cooking and displays starts counting down.

NOTE: If **EASY COOK** pad is pressed, 30 seconds will be added up to 3 minutes. After 3 minutes, every time **EASY COOK** pad is pressed, 1 minute will be added up to 99 minutes 59 seconds.

Time Cook

This function allows food to cook for a desired time, and in order to give you the best results. There are 10 power level settings in addition to HI-POWER, because many foods need slower cooking (at less than HI-POWER).

1. Enter desired time, by using number key pads.
2. Press **POWER LEVEL** pad.
 - P-HI appears in the display. This indicates that the oven is set on HI, unless a different power setting is chosen.
3. Press a number pad indicating the desired power level.
 - Display shows **P-XX**, indicating the percentage of power being used.
4. Press **START** pad.
 - When the cooking time is over, two short and one long tone sounds. The word "End" is indicated in the display window. Then the oven shuts itself off.

NOTE: If you do not select the power level, the oven will operate at power HIGH. To set HI-POWER cooking, skip steps 2 & 3 above.

Multi-Stage Time Cook

This feature allows multiple stage cooking.

1. Press **PROGRAM** pad.
2. Repeat **TIME COOK** steps 1 - 3.
3. Press **START** pad.

NOTE: Auto Defrost can be programmed before the first stage to defrost first and then perform cooking.

Programming Instructions for ACM0860A* and MMC5086A*

Child Lock

This is a unique safety feature that locks out the control panel, preventing all oven operations.

1. Press **STOP/CLEAR** pad.
2. Press and hold **0**, until "L" appears in the display and two beeps have sounded.

NOTE: Once child lock has been engaged, "L" will appear in the display if any cooking function is pressed.

- Perform procedure again to deactivate the child lock.

Control Set-Up

This function provides five different modes that can be changed.

1. Press **CONTROL SET-UP** pad.
2. Press the number pad identifying with the first column in the chart below.

Number pad	Function	Option
1	Sound ON Sound OFF	1 2
2	Clock ON..... Clock OFF.....	1 2
3	Scroll speed	1Slow 2Normal 3Fast
4	Weight.....	1 lbs. 2 Kg.

3. Press the option number pad identifying with the function desired.

NOTE: The default settings are Sound ON, Clock ON, Normal Speed, LBS, and Demo OFF.

NOTE: Demo mode allows the oven to operate without oven heating functions.

More / Less

This feature allows all of the **AUTO COOK**, **TIME COOK**, **EASY COOK**, and **SENSOR COOK** programs to be adjusted for a longer or shorter cooking time.

1. Perform one of the cooking programs listed above.
2. Count down sequence must begin before adding or subtracting time can be performed.
 - Pressing **MORE** pad will add 10 seconds of cooking time each time it is pressed.
 - Pressing **LESS** pad will subtract 10 seconds of cooking time each time it is pressed.

Sensor Cook

This feature detects the amount of vapor build-up while cooking and automatically determines the cooking time for each food item.

- Press **COOK** pad.
 - Display scrolls the words: "SELECT MENU 1 TO 6 -- SEE COOKING GUIDE BEHIND DOOR".
 - Select the number pad that identifies with the type of food being prepared.

Sensor Popcorn

This feature detects the amount of vapor build-up while cooking and automatically determines the cooking time.

- Press **POPCORN** pad.

NOTE: Do not use any popcorn popping devices in this oven with this feature.

Warm Hold

This feature can be used by itself or to automatically follow a cooking cycle.

1. Press **WARM HOLD** pad.
 - Display scrolls the words: "HOLD WARM TOUCH START".
2. Press **START** pad.
 - Display will indicate "WARM" while the oven continues to operate.

NOTE: Allows cooked food to remain warm for up to 99 minutes and 59 seconds.

Auto Cook

The internal oven menu has 6 preprogrammed cooking functions to cook food automatically.

- Press **AUTO COOK** pad.
 - Read and follow the chart below to perform a cooking function.

Programming Instructions for ACM0860A* and MMC5086A*

separate or rearrange the food.

1. Press **AUTO DEFROST** pad, see chart below to determine the type of defrost cycle preferred.
 - Display scrolls the words: "MEAT TOUCH 1 POULTRY TOUCH 2 FISH TOUCH 3".
2. Enter number indicating type of food desired.
 - Display scrolls the words: "ENTER WEIGHT".

NOTE: Refer to OWNER'S manual for complete cooking instructions.

Auto Cook

The internal oven menu has 6 preprogrammed cooking functions to cook food automatically.

- Press **AUTO COOK** pad.
 - Read and follow the chart below to perform a cooking function.

Menu	Category	Serving size
1	Bacon	2 – 6 slices
2	Frozen Roll/Muffin	1 – 6 pieces (2 – 3 ounces each)
3	Fresh Roll/Muffin	1 – 6 pieces (2 – 3 ounces each)
4	Beverage	1 – 2 cups
5	Chicken Pieces	½ - 2.0 lbs.
6	Hot Cereal	1 – 6 servings

NOTE: Refer to OWNER'S manual for complete cooking instructions.

Rapid Defrost

This feature allows quick defrosting for 1.0 lb. of frozen food.

- Press **RAPID DEFROST** pad.
 - Oven begins to defrost the food.

Auto Defrost

This feature has three different defrost levels that will automatically set the defrost time and power level according to the weight of the food.

For added convenience, this cycle includes a built-in beep mechanism that reminds you to check, turn over,

Pad	Sequence	Food
Press pad number 1	MEAT	BEEF Ground beef, Round steak, Cubes for stew, Tenderlion steak, Pot roast, Rib roast, Rump roast, Chuck roast, Hamburger patty LAMB Chop (1 inch thick), Rolled roast PORK Chop (1/2 inch thick), Hot dogs, Spareribs, Country-style ribs, Rolled roast, Sausage VEAL Cutlets (1 lb. ½ inch thick)
Press pad number 2	POULTRY	POULTRY Whole (under 4 lbs.), Cut up breast (boneless) CORNISH HENS Whole TURKEY Breast (under 6 lbs.)
Press pad number 3	FISH	FISH Fillets, Whole steaks SHELLFISH Crab meat, Lobster tails, Shrimp, Scallops

3. Enter the weight of the food.
 - Available weight is 0.1 to 6.0 lbs.
4. Press **START** pad.

NOTE: The oven **will not stop** during the BEEP unless the oven door is opened.

NOTE: Refer to OWNER'S manual for complete instructions on COOKING CHART.



Appendix C

Cleaning Instructions

CAUTION

To avoid risk of damage, unplug the microwave oven or disconnect power at the source by removing fuse or tripping the circuit breaker.

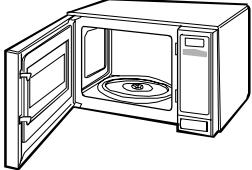
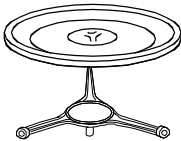
Before cleaning the oven, unplug the power supply cord of the oven. If impossible, open the oven door to prevent an accidental oven start.

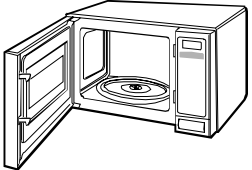
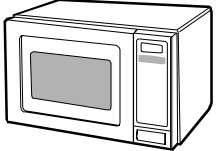
Part	Description
<p>Inside the oven</p> 	<ul style="list-style-type: none"> • Use a damp cloth to wipe out any crumbs and spillovers. • It is important to keep the area between the oven door and cavity front to assure a tight seal. • Remove grease spatters with a warm soapy water solution, rinse, and dry thoroughly. • Do not use any harsh detergents or abrasive cleaners.
<p>Glass tray</p> 	<ul style="list-style-type: none"> • Glass can be hand washed or placed in a dishwasher for cleaning.
<p>Control panel</p> 	<ul style="list-style-type: none"> • Wipe with a damp soft cloth followed immediately by a clean soft dry cloth. • Child lock feature is helpful when cleaning the control panel. <ul style="list-style-type: none"> • This feature prevents accidental programming when wiping the control panel.
<p>Door</p> 	<ul style="list-style-type: none"> • If steam accumulates inside or around the outside of the oven door, wipe the panel with a clean soft dry cloth. • This may occur when the microwave oven is operating under a high humidity condition and in no way indicates a malfunction of the unit.
<p>Outside oven surface</p> 	<ul style="list-style-type: none"> • Clean with a damp soft cloth. • To prevent damage to the operating parts inside the oven, the water should not be allowed to seep into the ventilation openings.

After cleaning the oven, verify the rotating ring and glass tray are placed in the correct position.

Press the STOP/CLEAR pad twice to reset any accidental key settings.