

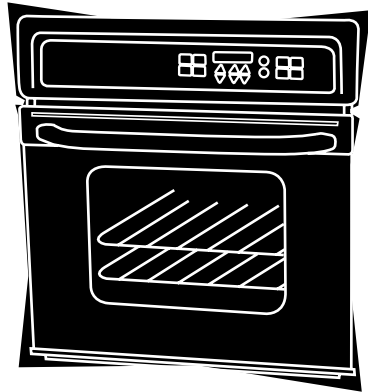

TECHNICAL SERVICE GUIDE

27-In. Built-In Electric Wall Oven



MODEL SERIES:

ZEK957	ZEK937
JKP56	JCKP15
JKP45	JKP15
JKP27	JCKS05
JCKP18	JKS05
JKP18	JKP85





IMPORTANT SAFETY NOTICE

The information in this service guide is intended for use by individuals possessing adequate backgrounds of electrical, electronic, and mechanical experience. Any attempt to repair a major appliance may result in personal injury and property damage. The manufacturer or seller cannot be responsible for the interpretation of this information, nor can it assume any liability in connection with its use.

WARNING

To avoid personal injury, disconnect power before servicing this product. If electrical power is required for diagnosis or test purposes, disconnect the power immediately after performing the necessary checks.

RECONNECT ALL GROUNDING DEVICES

If grounding wires, screws, straps, clips, nuts, or washers used to complete a path to ground are removed for service, they must be returned to their original position and properly fastened.

GE Consumer Home Services Training
Technical Service Guide
Copyright © 2001

All rights reserved. This service guide may not be reproduced in whole or in part in any form without written permission from the General Electric Company.

Table of Contents

Introduction	3
Nomenclature	4
Control Panel Features	5
Component Locator Views	11
Oven	15
Lift-Off Oven Door	15
Door Assembly	15
Oven Door Gasket	16
Door Hinge Assemblies	17
Door Hinge Replacement	17
Component Compartment Airflow	17
Electronic Oven Control System	18
Control Panel	18
Electronic Control (EC)	18
Control Voltage	19
Key Panel Test	19
Ohmmeter Test	20
ERC Failure Codes	21
Special Functions	23
Oven Sensor and Sensor Circuits	23
Oven Sensor and Door Switch Ohmmeter Test	24
Sensor and Lock Switch Connectors	24
Oven Circuits	25
Oven Calibration	25
Motorized Door Lock	26
Oven Thermal Switch	27
Lock Thermal Switch	27
Fan Switch	27
Convection Bake Element and Fan Assembly	28

Table of Contents

Microwave	29
Microwave Removal	30
Microwave Outer Case Removal	30
Microwave Door	30
Microwave Control Panel	31
Microwave Power Control Board (PCB)	32
Microwave Low-Voltage Transformer	32
Microwave Key Panel Test	33
Microwave High-Voltage Capacitor	33
Microwave High-Voltage Diode	34
Microwave High-Voltage Transformer	35
Microwave Magnetron	35
Microwave Magnetron Fan	36
Microwave Magnetron TCO	36
Microwave Fan Thermal Switch	37
Microwave Fuse	37
Microwave Flame TCO	37
Microwave Gas (Humidity) Sensor	38
Microwave Interlocks and Monitor	38
Microwave Oven Lamp Assembly	40
Microwave Turntable Motor	40
Microwave Performance Test	40
Microwave Leak Test	40
Microwave Fault Codes	41
Microwave Diagnostic Charts	42
Schematics and Wiring Diagrams	45
Quiz	66
Warranties	67

Introduction

Model JKP45



Model JKP85



The new 27-in. Built-In Electric Wall Ovens make an eloquent statement of style, convenience, and kitchen planning flexibility. **Added to the single oven and double oven models is our new microwave-and-oven combination unit.**

The Electronic Touch Controls are simple to

understand and easy to operate. Just read and touch. It's easy to see how GE's fresh ideas can make anyone more creative in the kitchen!

The information on the following pages will help you service these new 27-in. Built-In Electric Wall Ovens effectively and efficiently.

Nomenclature

Model Number

J K P 4 5 C D 1 C C

GE Cooking Product
ZE = Monogram Electric

Configuration

K = 27-in. Wall Oven
CK = Camco 27-in. Wall Oven

Oven Type

P = Self Clean
S = Standard

Feature Pack

Designates features—the higher the number, the more features.

Product Color

CC = Bisque WW = White
BB = Black AA = Almond
SS = Stainless Steel

Indicator for Engineering and Product Service Only

Model Year Designator

Glass Color

C = Bisque W = White
B = Black A = Almond
S = Stainless Steel

Model JKP15



The model/serial number tag of your built-in oven is located behind the door to the left. For the double ovens, the tag is located in the upper oven. In addition to the model and serial numbers, this plate shows the power ratings of the supply circuit for the oven.

Serial Number

The first two characters of the serial number identify the month and year of manufacture.

Example: **AA**123456S = January, 2001

A - JAN	2005 - H
D - FEB	2004 - G
F - MAR	2003 - F
G - APR	2002 - D
H - MAY	2001 - A
L - JUN	2000 - Z
M - JUL	1999 - V
R - AUG	1998 - T
S - SEP	1997 - S
T - OCT	1996 - R
V - NOV	1995 - M
Z - DEC	1994 - L

The letter designating the year repeats every 12 years.

Example:

T - 1974
T - 1986
T - 1998

Note: The technical sheet is located under the control panel.

Control Panel Features

Oven Controls Model JKP15

Throughout this manual, features and appearance may vary from your model.

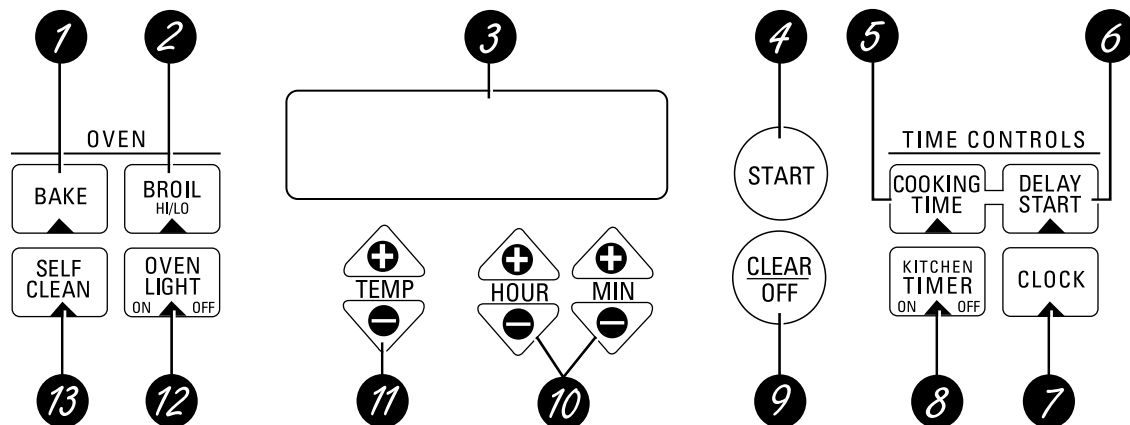

Oven Control, Clock and Timer Features and Settings

- 1 BAKE Pad**
Press this pad to select the bake function.
- 2 BROIL HI/LO Pad**
Press this pad to select the broil function.
- 3 Display**
Shows the time of day, oven temperature, whether the oven is in the bake, broil or self-cleaning mode and the times set for the timer or automatic oven operations.

If "F— and a number or letter" flash in the display and the oven control signals, this indicates a function error code. Press the **CLEAR/OFF** pad. Allow the oven to cool for one hour. Put the oven back into operation. If the function error code repeats, disconnect the power to the oven and call for service.

If your oven was set for a timed oven operation and a power outage occurred, the clock and all programmed functions must be reset.

The time of day will flash in the display when there has been a power outage.
- 4 START Pad**
Must be pressed to start any cooking or cleaning function.
- 5 COOKING TIME Pad**
Press this pad and then press the number pads to set the amount of time you want your food to cook. The oven will shut off when the cooking time has run out.
- 6 DELAY START Pad**
Use along with **COOKING TIME** or **SELF CLEAN** pads to set the oven to start and stop automatically at a time you set.
- 7 CLOCK Pad**
Press this pad before setting the clock.
- 8 KITCHEN TIMER ON/OFF Pad**
Press this pad to select the timer feature.
- 9 CLEAR/OFF Pad**
Press this pad to cancel **ALL** oven operations except the clock and timer.
- 10 HOUR and MIN + and – Pads**
Press these pads to set times up to 9 hours and 59 minutes—for example, the time of day on the clock, the timer, the starting and length of cooking time for timed bake and the starting and length of cleaning time for self-clean.
- 11 TEMP + and – Pads**
Press these pads to set the cooking temperature you want to use.
- 12 OVEN LIGHT ON/OFF Pad**
Press this pad to turn the oven light on or off.
- 13 SELF CLEAN Pad**
Press this pad to select the self-cleaning function. See the *Using the self-cleaning oven* section.

Oven Controls Models ZEK957, ZEK937, JKP56, and JKP18

Throughout this manual, features and appearance may vary from your model.

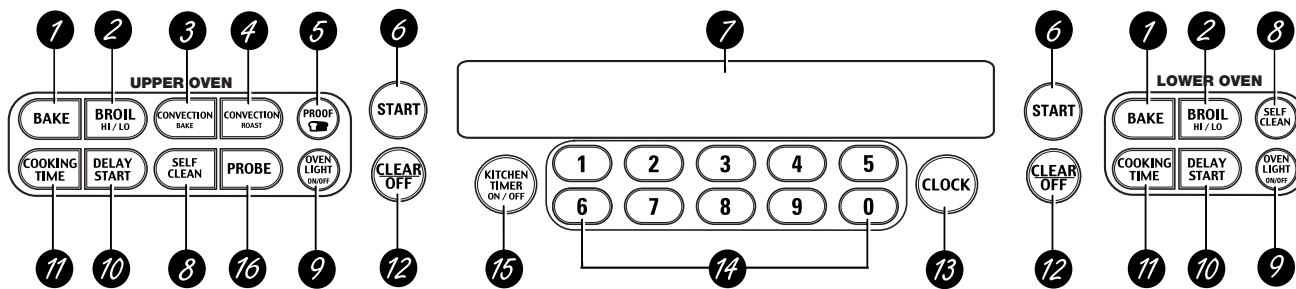

Double oven control shown.

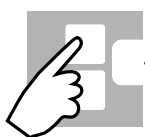

Oven Control, Clock and Timer Features and Settings

- 1 BAKE Pad**
Press this pad to select the bake function.
 - 2 BROIL HI/LO Pad**
Press this pad to select the broil function.
 - 3 CONVECTION BAKE Pad**
Press this pad to select baking with the convection function.
 - 4 CONVECTION ROAST Pad**
Press this pad to select roasting with the convection function.
 - 5 PROOF Pad**
Press this pad to select a warm environment useful for rising yeast-leavened products.
 - 6 START Pad**
Must be pressed to start any cooking or cleaning function.
 - 7 Display**
Shows the time of day, oven temperature, whether the oven is in the bake, broil or self-cleaning mode and the times set for the timer or automatic oven operations.
- If “F– and a number or letter” flash in the display and the oven control signals, this indicates a function error code.** Press the **CLEAR/OFF** pad. Allow the oven to cool for one hour. Put the oven back into operation. If the function error code repeats, disconnect the power to the oven and call for service.
- If your oven was set for a timed oven operation and a power outage occurred, the clock and all programmed functions must be reset.**
- The time of day will flash in the display when there has been a power outage.**
- 8 SELF CLEAN Pad**
Press this pad to select the self-cleaning function. See the *Using the self-cleaning oven* section.
 - 9 OVEN LIGHT Pad**
Press this pad to turn the oven light on or off.
 - 10 DELAY START Pad**
Use along with **COOKING TIME** or **SELF CLEAN** pads to set the oven to start and stop automatically at a time you set.
 - 11 COOKING TIME Pad**
Press this pad and then press the number pads to set the amount of time you want your food to cook. The oven will shut off when the cooking time has run out.
 - 12 CLEAR/OFF Pad**
Press this pad to cancel **ALL** oven operations except the clock and timer.
 - 13 CLOCK Pad**
Press this pad before setting the clock.
 - 14 Number Pads**
Use to set any function requiring numbers such as the time of day on the clock, the timer, the oven temperature, the internal food temperature, the start time and length of operation for timed baking and self-cleaning.
 - 15 KITCHEN TIMER ON/OFF Pad**
Press this pad to select the timer feature.
 - 16 PROBE Pad**
Press this pad when using the probe to cook food.

Oven Controls Models JKP45 and JKP27

Throughout this manual, features and appearance may vary from your model.

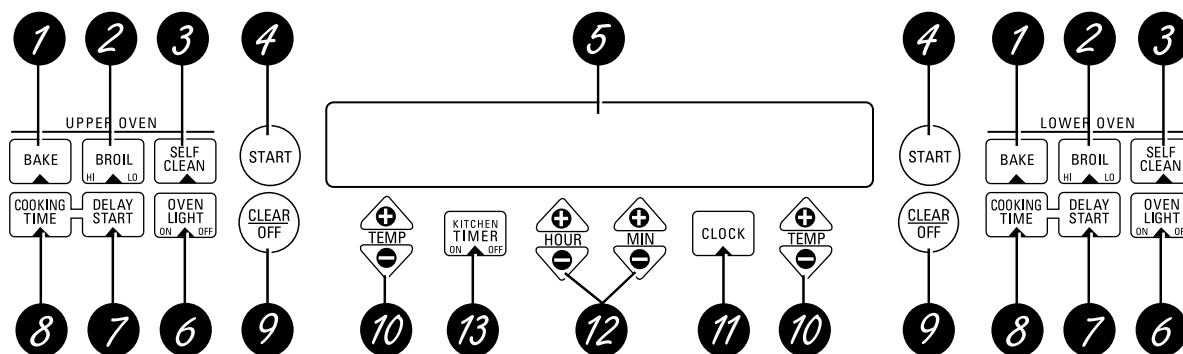

(on some models)



Oven Control, Clock and Timer Features and Settings

- 1 BAKE Pad**
Press this pad to select the bake function.
- 2 BROIL HI/LO Pad**
Press this pad to select the broil function.
- 3 SELF CLEAN Pad**
Press this pad to select the self-cleaning function. See the *Using the self-cleaning oven* section.
- 4 START Pad**
Must be pressed to start any cooking or cleaning function.
- 5 Display**
Shows the time of day, oven temperature, whether the oven is in the bake, broil or self-cleaning mode and the times set for the timer or automatic oven operations.

If "F— and a number or letter" flash in the display and the oven control signals, this indicates a function error code. Press the **CLEAR/OFF** pad. Allow the oven to cool for one hour. Put the oven back into operation. If the function error code repeats, disconnect the power to the oven and call for service.

If your oven was set for a timed oven operation and a power outage occurred, the clock and all programmed functions must be reset.

The time of day will flash in the display when there has been a power outage.
- 6 OVEN LIGHT ON/OFF Pad**
Press this pad to turn the oven light on or off.
- 7 DELAY START Pad**
Use along with **COOKING TIME** or **SELF CLEAN** pads to set the oven to start and stop automatically at a time you set.
- 8 COOKING TIME Pad**
Press this pad and then press the **HOUR** and **MIN +** and **-** pads to set the amount of time you want your food to cook. The oven will shut off when the cooking time has run out.
- 9 CLEAR/OFF Pad**
Press this pad to cancel **ALL** oven operations except the clock and timer.
- 10 TEMP + and – Pads**
Press these pads to set the cooking temperature you want to use.
- 11 CLOCK Pad**
Press this pad before setting the clock.
- 12 HOUR and MIN + and – Pads**
Press these pads to set times up to 9 hours and 59 minutes—for example, the time of day on the clock, the timer, the starting and length of cooking time for timed bake and the starting and length of cleaning time for self-clean.
- 13 KITCHEN TIMER ON/OFF Pad**
Press this pad to select the timer feature.

Lower Oven Control Settings on models with a knob

OVEN Knob
Turn this knob to the temperature setting you want.

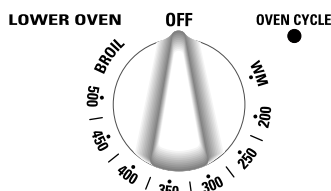

The **OVEN CYCLE** light glows until the oven reaches your selected temperature, then goes off and on with the oven element(s) during cooking.

Oven Controls Model JKS05

Throughout this manual, features and appearance may vary from your model.

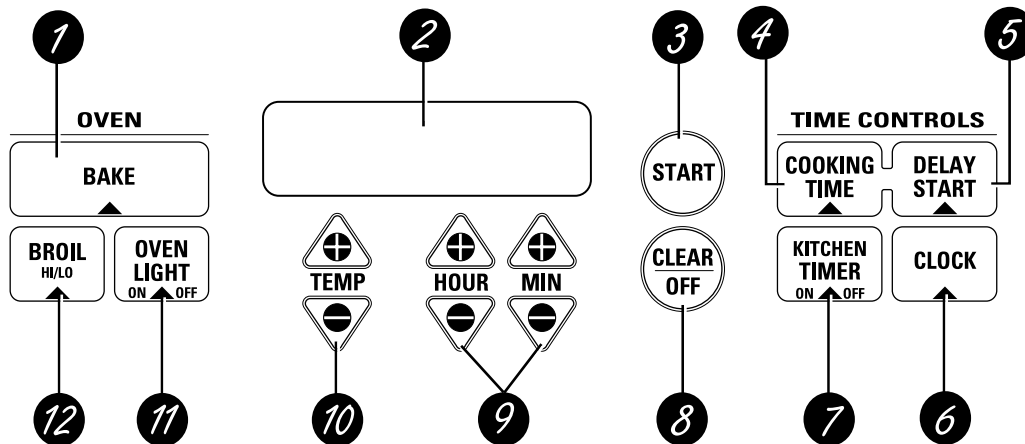

Oven Control, Clock and Timer Features and Settings

- 1 BAKE Pad**
Press this pad to select the bake function.
- 2 Display**
Shows the time of day, oven temperature, whether the oven is in the bake or broil mode and the times set for the timer or automatic oven operations.
- If "F— and a number or letter" flash in the display and the oven control signals, this indicates a function error code.** Press the **CLEAR/OFF** pad. Allow the oven to cool for one hour. Put the oven back into operation. If the function error code repeats, disconnect the power to the oven and call for service.
- If your oven was set for a timed oven operation and a power outage occurred, the clock and all programmed functions must be reset.**
- The time of day will flash in the display when there has been a power outage.**
- 3 START Pad**
Must be pressed to start any cooking function.
- 4 COOKING TIME Pad**
Press this pad and then press the number pads to set the amount of time you want your food to cook. The oven will shut off when the cooking time has run out.
- 5 DELAY START Pad**
Use along with **COOKING TIME** pad to set the oven to start and stop automatically at a time you set.
- 6 CLOCK Pad**
Press this pad before setting the clock.
- 7 KITCHEN TIMER ON/OFF Pad**
Press this pad to select the timer feature.
- 8 CLEAR/OFF Pad**
Press this pad to cancel **ALL** oven operations except the clock and timer.
- 9 HOUR and MIN + and – Pads**
Press these pads to set times up to 9 hours and 59 minutes—for example, the time of day on the clock, the timer, the starting and length of cooking time for timed bake .
- 10 TEMP + and – Pads**
Press these pads to set the cooking temperature you want to use.
- 11 OVEN LIGHT ON/OFF Pad**
Press this pad to turn the oven light on or off.
- 12 BROIL HI/LO Pad**
Press this pad to select the broil function.

Oven Controls Model JKP85

Throughout this manual, features and appearance may vary from your model.

Note: The time on the microwave display is shown in minutes and seconds (1:30 is one minute, 30 seconds). On the lower oven, time is shown in hours and minutes (1:30 is one hour, 30 minutes).

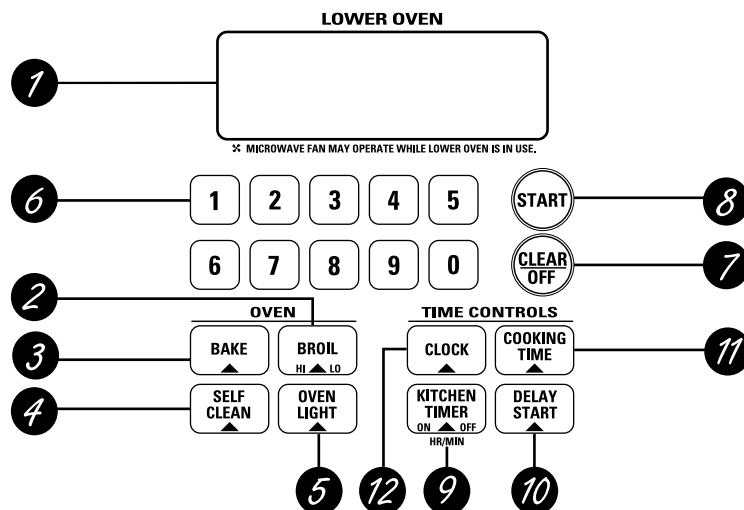

Lower Oven Control, Clock and Timer Features and Settings

- 1 Display**

Shows the time of day, oven temperature, whether the oven is in the bake, broil or self-cleaning mode and the times set for the timer or automatic oven operations.

If "F- and a number or letter" flash in the display and the oven control signals, this indicates a function error code. Press the **CLEAR/OFF** pad. Allow the oven to cool for one hour. Put the oven back into operation. If the function error code repeats, disconnect the power to the oven and call for service.

If your oven was set for a timed oven operation and a power outage occurred, the clock and all programmed functions must be reset.

The time of day (may be incorrect) will flash in the display when there has been a power outage.
- 2 BROIL HI/LO Pad**

Press this pad to select the broil function.
- 3 BAKE Pad**

Press this pad to select the bake function.
- 4 SELF CLEAN Pad**

Press this pad to select the self-cleaning function. See the *Using the self-cleaning lower oven* section.
- 5 OVEN LIGHT Pad**

Press this pad to turn the oven light on or off.
- 6 Number Pads**

Use to set any function requiring numbers such as the time of day on the clock, the timer, the oven temperature, the start time and length of operation for timed baking and self-cleaning.
- 7 CLEAR/OFF Pad**

Press this pad to cancel **ALL** oven operations except the clock and timer.
- 8 START Pad**

Must be pressed to start any cooking or cleaning function.
- 9 KITCHEN TIMER ON/OFF Pad**

Press this pad to select the timer feature.
- 10 DELAY START Pad**

Use along with **COOKING TIME** or **SELF CLEAN** pads to set the oven to start and stop automatically at a time you set.
- 11 COOKING TIME Pad**

Press this pad and then press the number pads to set the amount of time you want your food to cook. The oven will shut off when the cooking time has run out.
- 12 CLOCK Pad**

Press this pad before setting the clock.

Microwave Controls

Model JKP85

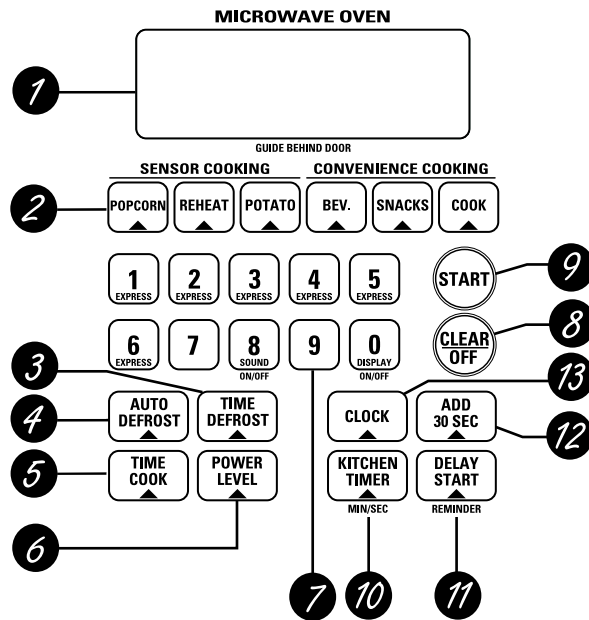

Microwave Oven Control Features and Settings

- 1 Display**
Displays the time during cooking functions, the power level being used, the Auto Codes, the Auto Defrost food weights, the cooking mode and instructions.
- 2 AUTO SENSOR AND CONVENIENCE CONTROLS**
The top row of pads lists specific items you may choose to heat or cook.
- POPCORN**
Use to pop popcorn.
- REHEAT**
Use when foods need a quick warm up.
- POTATO**
Use when cooking whole potatoes.
- BEVERAGE**
Use to heat a cup of coffee or other beverage.
- SNACKS**
Use to warm a variety of snack foods.
- COOK**
Use to automatically set the cooking times and power levels for a variety of foods.
- 3 TIME DEFROST**
Use Time Defrost for most other foods.
- 4 AUTO DEFROST**
Use Auto Defrost for meat, poultry and fish.
- 5 TIME COOK**
Allows you to microwave for any time up to 99 minutes and 59 seconds.
- 6 POWER LEVEL**
Press to choose the power level you want to set. Watch the display while pressing this pad to select the power level.
- 7 Number Pads**
After pressing a function pad, press the number pads to set the exact amount of time you want to cook for. For example; if you press the **1, 2** and **5** pads, you have set 1 minute and 25 seconds.
- 8 CLEAR/OFF**
Press once to interrupt or change a function. Press twice to clear the display.
- 9 START**
After all selections are made, press this pad to start the oven. The **START** pad must be pressed to turn on any function.
- 10 KITCHEN TIMER MIN/SEC**
Press to set the timer up to 99 minutes and 59 seconds. Press the number pads to set the time. Press the **KITCHEN TIMER MIN/SEC** pad. Press the **KITCHEN TIMER MIN/SEC** pad twice to clear the display.
Does not turn on microwave energy.
This timer cannot be used while the microwave is being used. Use the lower oven timer.
- 11 DELAY START**
Allows you to set the microwave to delay cooking up to 24 hours.
- 12 ADD 30 SEC**
Each time you press this pad the set time is increased 30 seconds.
- 13 CLOCK**
Press this pad before setting the clock.

Component Locator Views

Model JKP85 (Microwave)

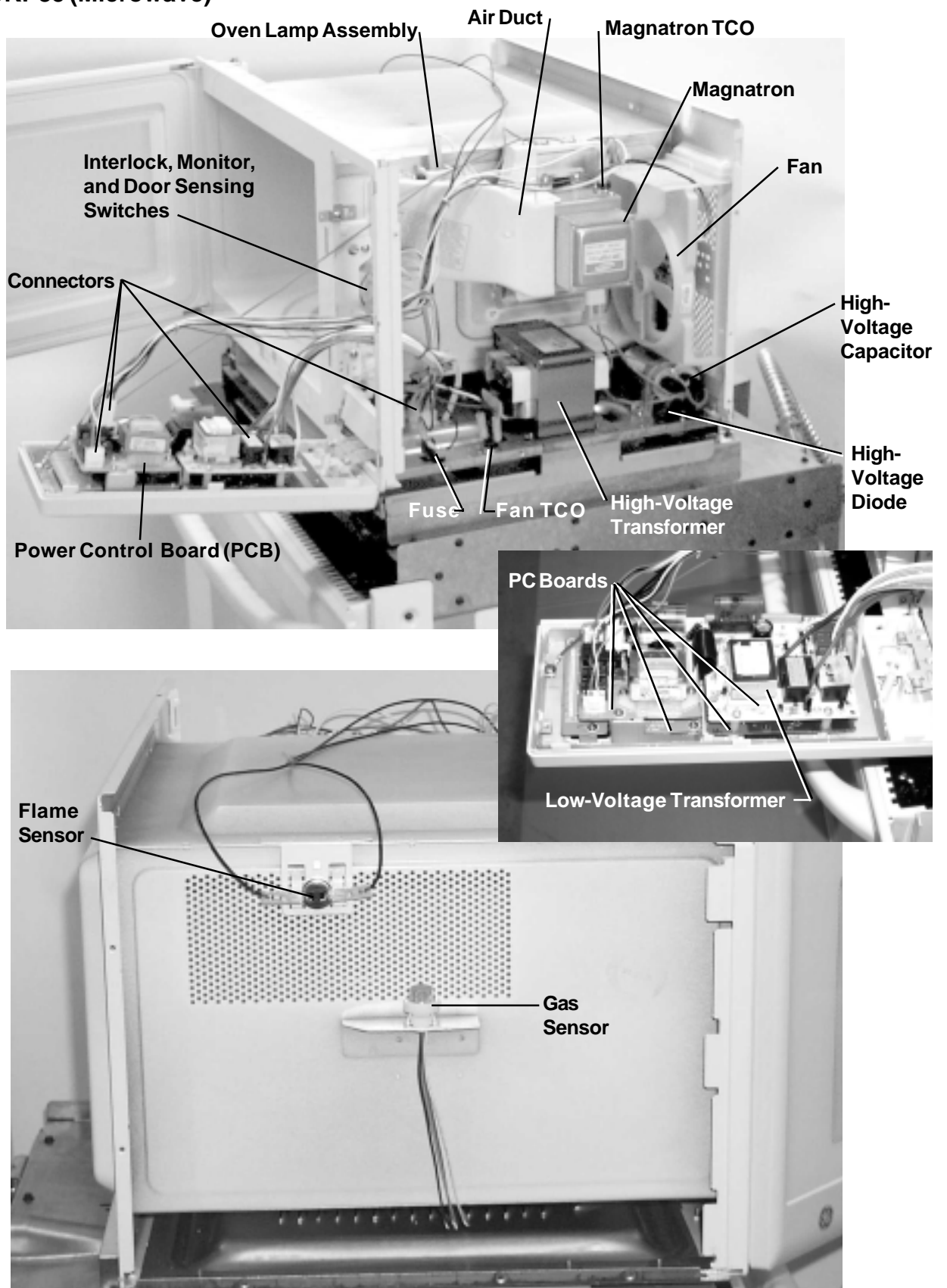

Model JKP45 (Double Oven)

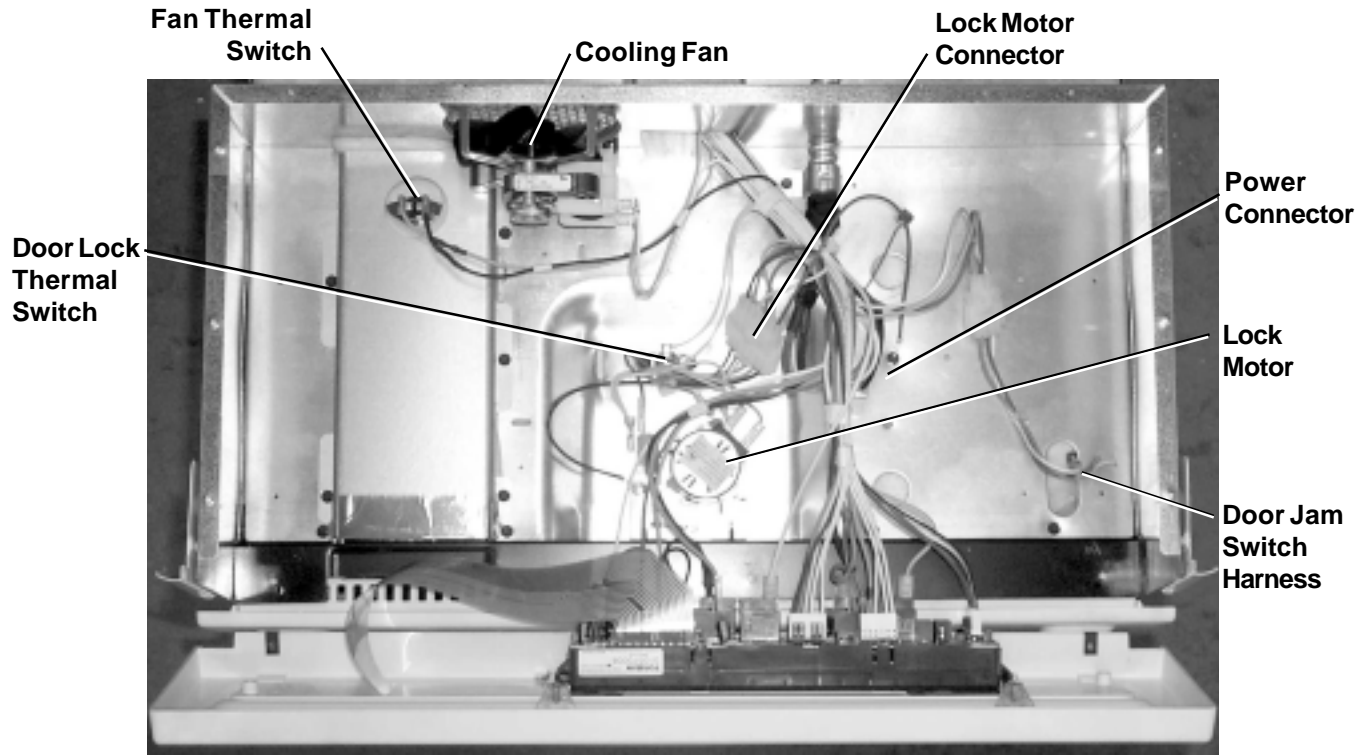

Top View

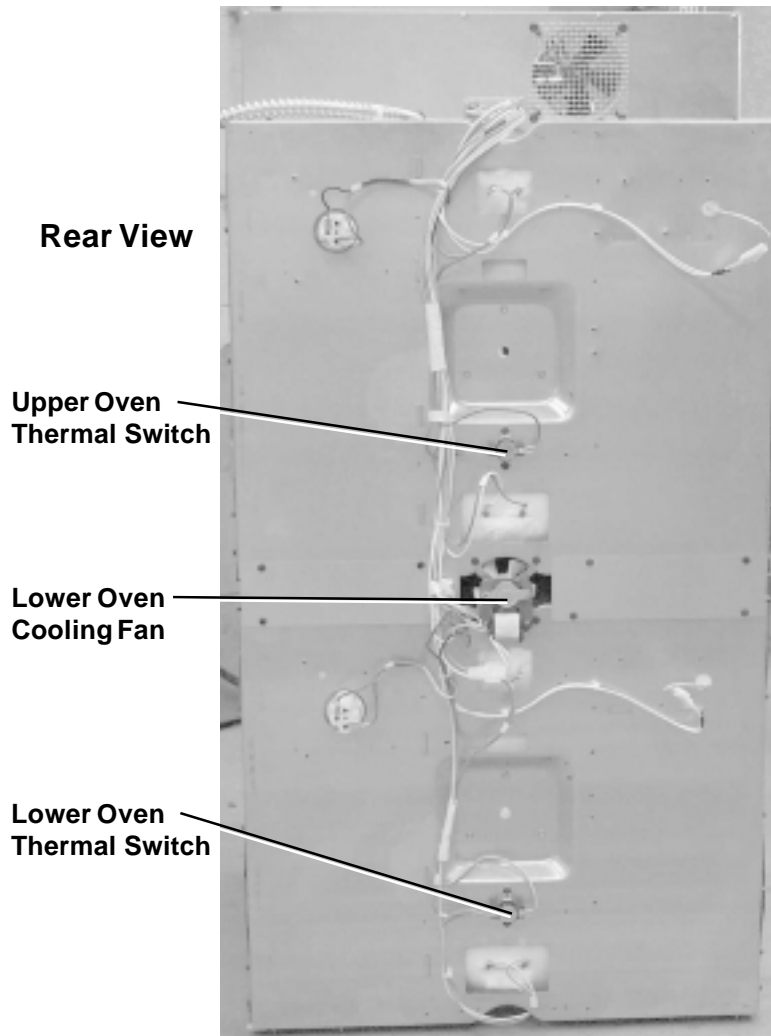

Model JKP45 (Double Oven)

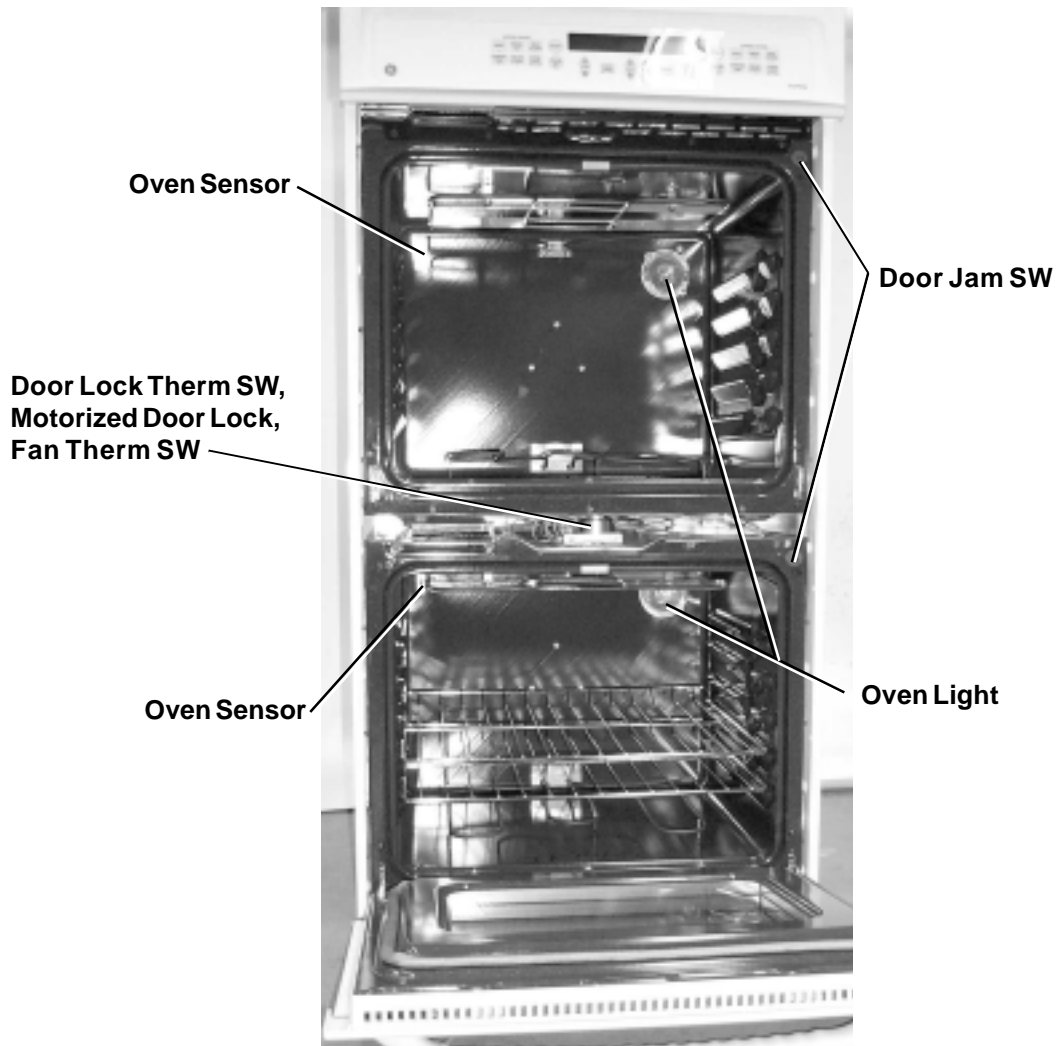
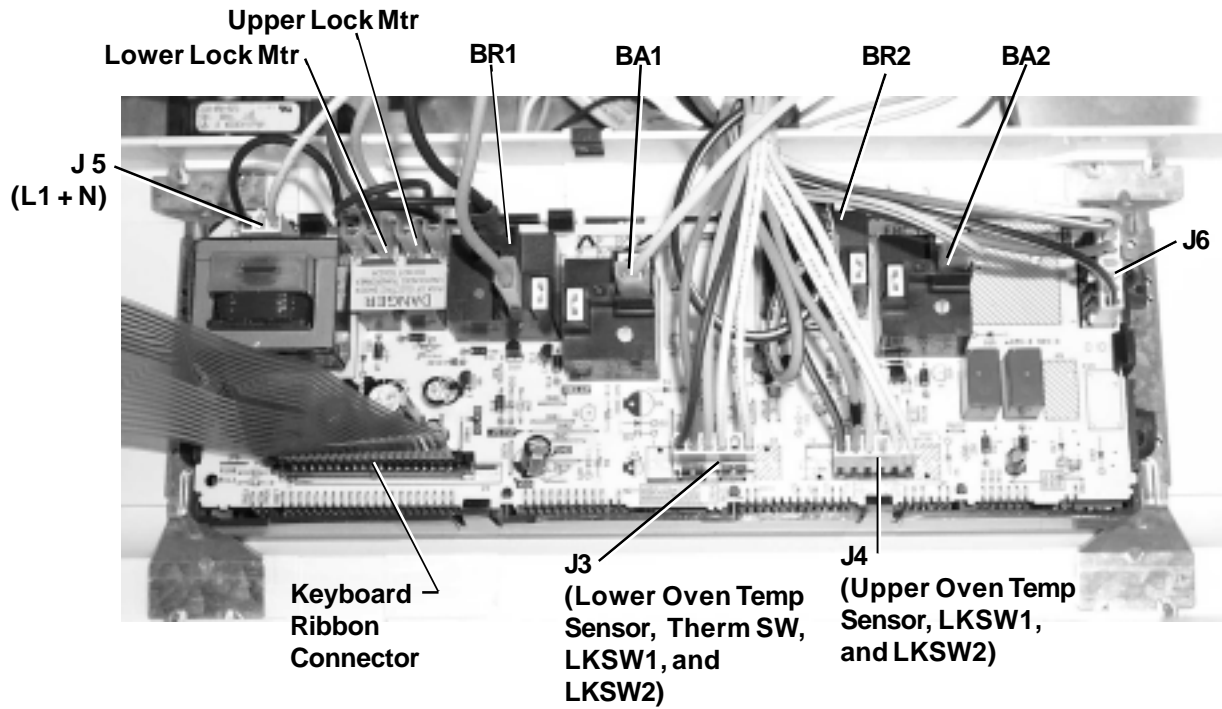

Model JKP15 (Single Oven)

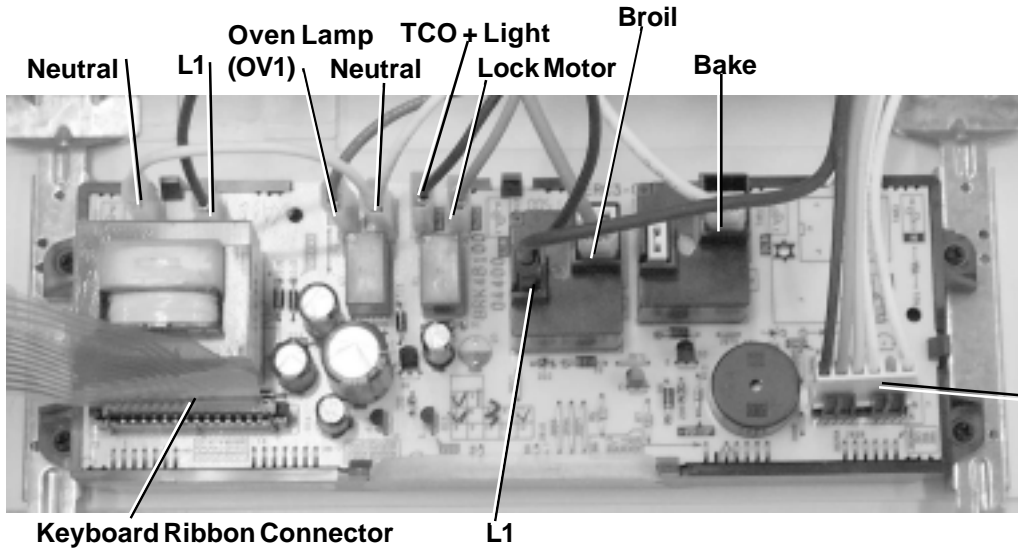

Lock Motor, Oven Sensor, LKSW 1, LKSW 2

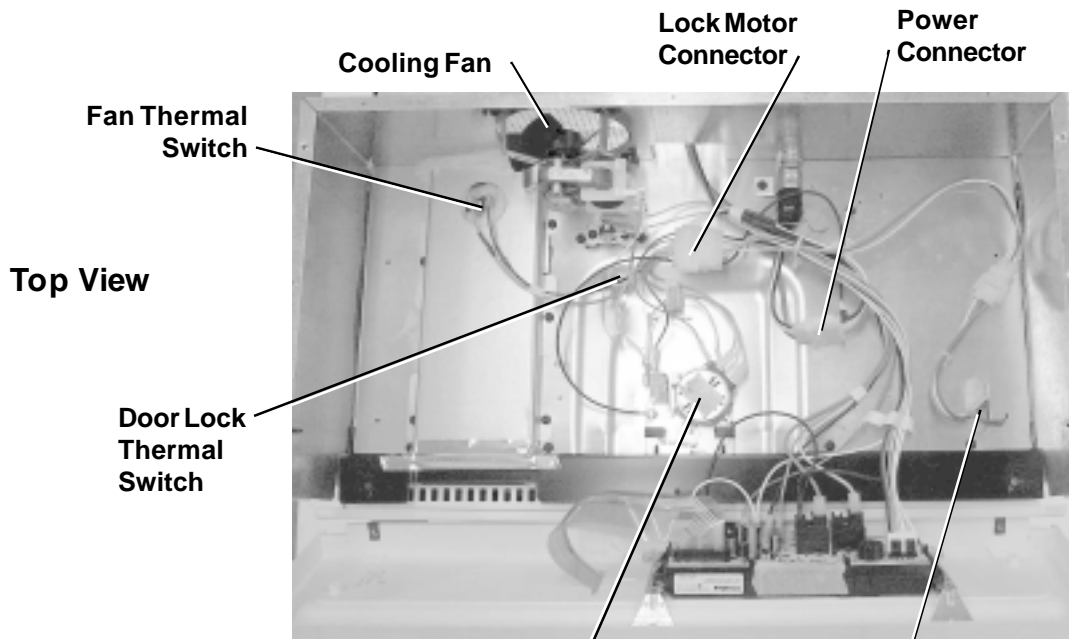

Top View

Rear View

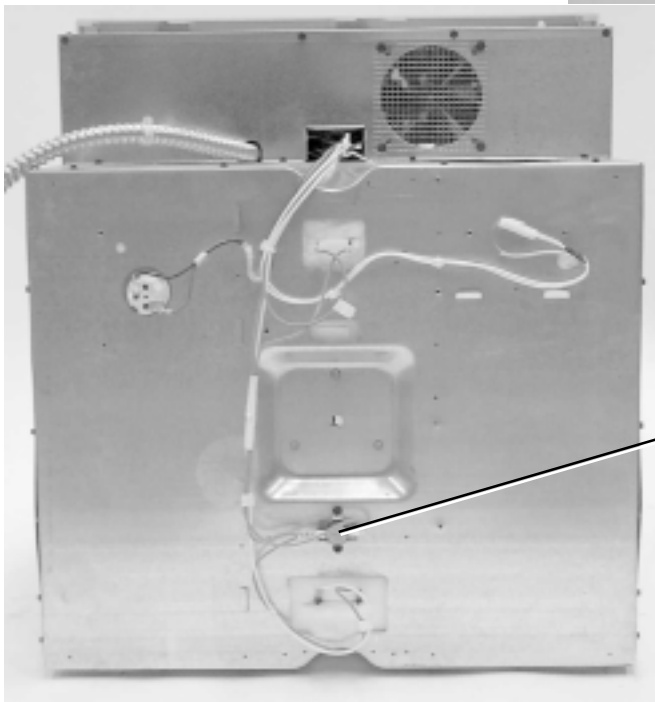

Oven Thermal Switch

Oven

Lift-Off Oven Door

Caution: Do not lift the door by the handle.

To remove the door:

1. Fully open the door.
2. Push the hinge locks down toward the door frame, to the unlocked position. This may require a flat-blade screwdriver to start the hinge locks moving.
3. Firmly grasp both sides of the door at the top.
4. Close the door to the door removal position, which is halfway between the broil stop position and fully closed.
5. Lift the door up and out until the hinge arm is clear of the slot.

To replace the door:

1. Firmly grasp both sides of the door at the top.
2. With the door at the same angle as the removal position, seat the indentation of the hinge arm into the bottom edge of the hinge slot. **The notch in the hinge arm must be fully seated into the bottom of the slot.**
3. Fully open the door.
4. Push the hinge locks up against the front frame of the oven cavity, to the locked position.
5. Close the oven door.

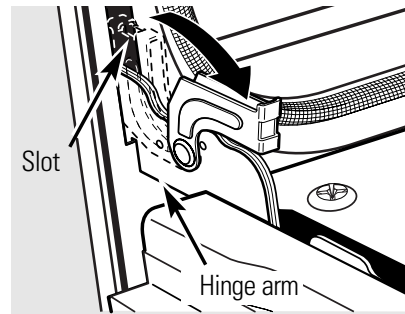

Hinge lock (unlocked position)

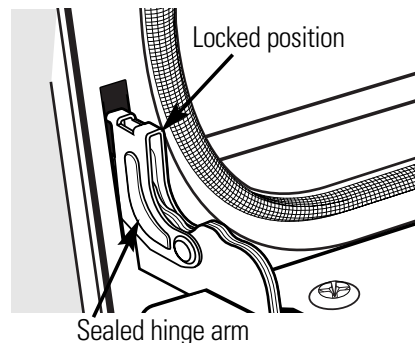
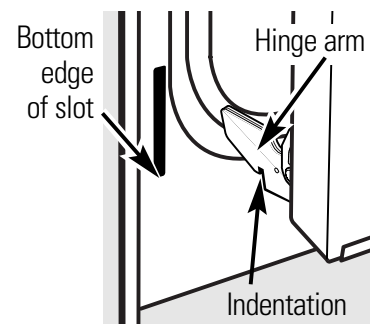

Door Assembly

The door assembly can be broken down into 2 basic assemblies: 1) The outer assembly consists of the door handle, vent trim, outer glass, bottom trim, and frame and 2) The inner assembly is made up of the inner panel, gasket, 3 glass panels, and insulation. The assemblies are held together by 2 screws on each side and 3 screws across the bottom.

To replace outer door assembly:

1. Remove the door. Refer to **Lift-Off Oven Door**.
2. Remove 3 screws from the bottom door frame.

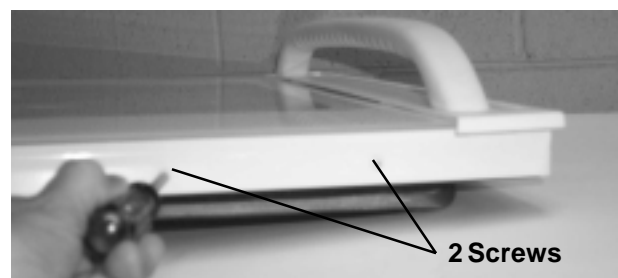
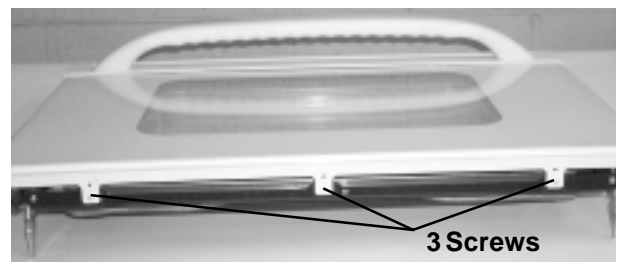

3. Remove 2 screws from each side of the door on the liner.
4. Separate the liner assembly and the outer glass assembly.
5. Remove 2 screws from the door handle near the door vent trim.
6. Slide the bottom trim and the top vent trim out to free the outer door glass.
7. Reassemble in reverse order.

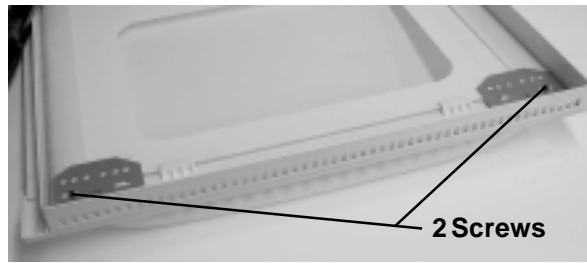

To replace liner assembly:

1. Remove 3 screws on each side of the door liner to remove the door hinge assembly.
2. Remove 4 screws from the insulation retainer.
3. Remove 6 screws and the insulation retainer. The window pack and window gasket are now accessible on units with a window door.

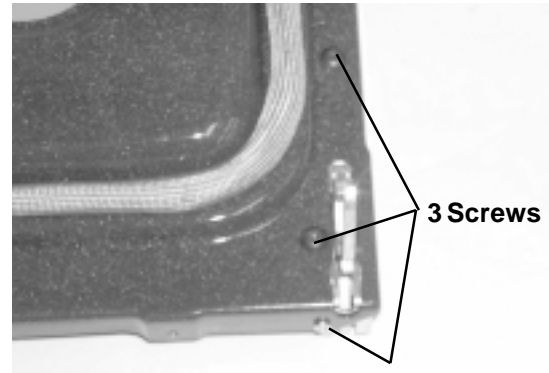

Caution: Care must be taken when mounting door handle not to overtighten screws. Overtightening screws can damage handle. **Hand tighten ONLY.** Make sure handle fits snug to door panel.

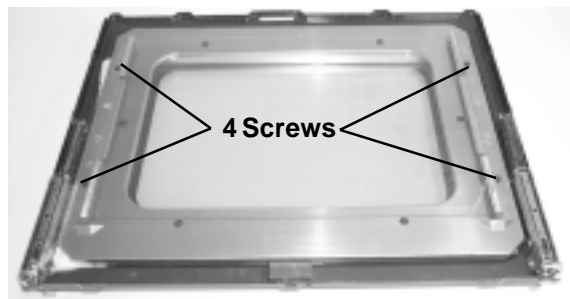

Oven Door Gasket

The gasket forms a seal around the front edge of the oven liner and the inner door panel except for approximately a 6-in. opening at the center bottom. The gasket is attached to the inner door panel by a chain of spring clips.

To remove door gasket:

1. Open the door completely.
2. Pull the end of the gasket out of the slots at the bottom of the door.
3. Finish removing the gasket by placing a finger under the gasket beside the clip and pulling straight up.



To install gasket:

1. Locate the 2 clips on the gasket just right and left of center.

Note: The gasket will go on easier if folded 90 degrees at the clip being inserted.

2. Place a finger on top of the spring clip and press into the 2 center top holes in the inner door panel.



3. Continue this process all the way around the inner panel until all clips have been inserted.
4. With a small screwdriver, tuck the loose ends of the gasket into the slots at the center bottom of the door panel. **Be sure to leave a 6-in. gap in the gasket at the bottom of the door.**
5. After the gasket has been installed, wipe a finger around the outer perimeter of the gasket, pressing it up against the side of the inner panel.

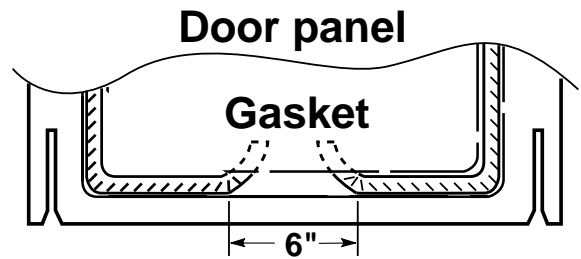

Door Hinge Assemblies

The door hinge comes as a complete assembly. The hinges are marked either as left (L) or right (R) hinge. For the hinges to operate properly, the hinge arms must be perpendicular to the front frame and parallel to each other.

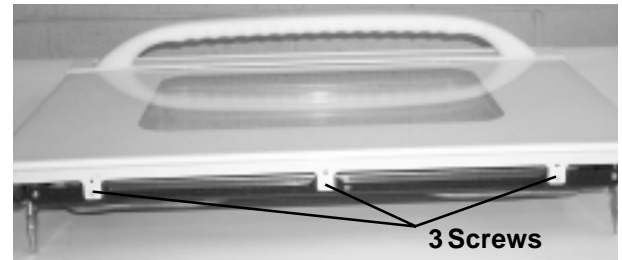

Door Hinge Replacement

1. Remove the door. Refer to **Lift-Off Oven Door**.
2. Remove 3 screws from the bottom door frame.
3. Remove 2 screws from each side of the door and separate the door liner and the outer glass assembly.
4. Remove 3 screws from the door liner to remove each door hinge assembly.

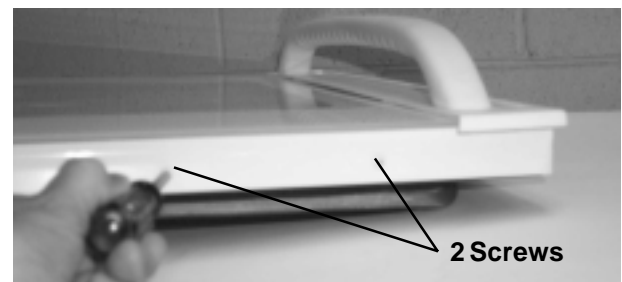

Note: When assembling, make sure the hinge arms are parallel to each other and perpendicular to the front frame. If not, the hinge may bind on the receiving channel of the door.

Note: If the new hinge is not in the cocked and locked position after installing, place the bottom of the door against a firm surface and push the hinge arm down to the cocked position. Pull the hinge lock back against the door liner surface to lock the hinge in this position.

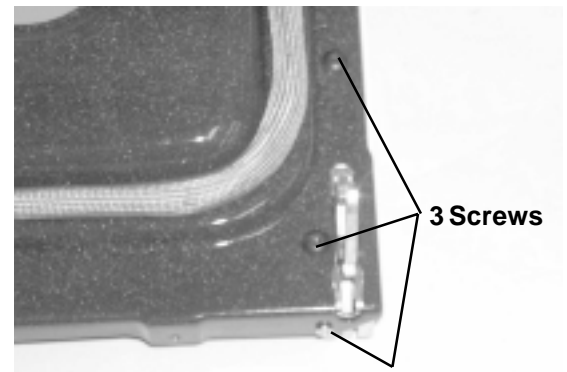

Component Compartment Airflow

The component compartment contains a fan located on the rear wall of the compartment. Fan blades pull air in from the back of the unit and circulate it in the compartment area to cool the components. The air is then exhausted through the louvers below the control panel.

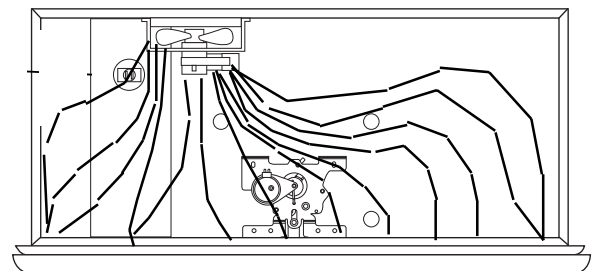

Electronic Oven Control System

The Electronic Oven Control System consists of the electronic control, key panel, oven sensor, and door lock assembly.

Control Panel

There are 5 basic control panel assemblies. They can be found listed by model number in the Control Panel Features section on pages 5 through 10.

Control Panel Access

1. Disconnect the power and open the oven door.
2. Remove 3 screws from across the bottom of the control panel.
3. Push up on the control panel assembly to release the top catches.

Electronic Control (EC)

Caution: Components are electronically hot on control when voltage is connected to range.

Note: Temperature/Mode Selection is necessary for operation of relay contacts.

Note: Voltage must be present across terminals L1 to N for control to operate.

There are 5 basic EC configurations (see illustration). The control contains the bake and broil relays, convection relay (some models), control transformer, lock motor relay (some models), sensor, and lock motor connector (some models), along with a series of 1/4-in. terminals for connecting power to the control and heating units.

Models ZEK937, JKP18, and JCKP18

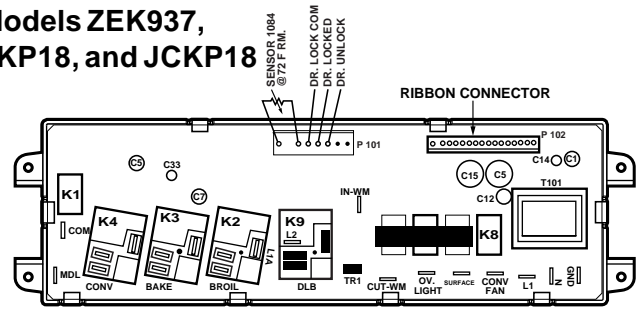

Models ZEK957, JKP56, and JKP45

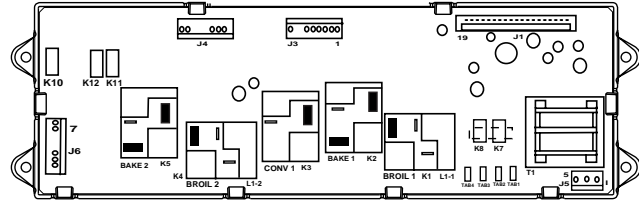

(K3, K6, K9, K10 Not on all models)

Models JKP15, JCKP15, and JKP27

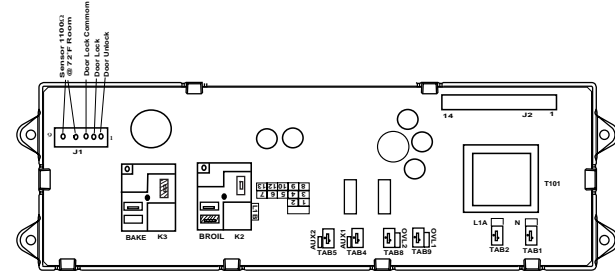

Models JKS05 and JCKS05

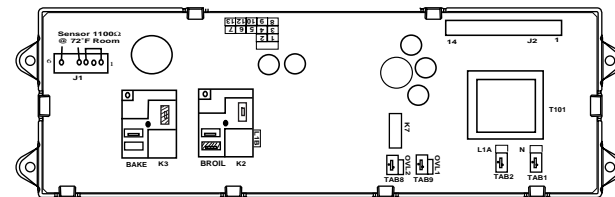

Model JKP85

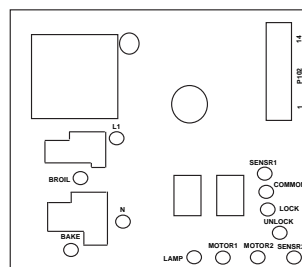

Control Voltage

Model JCKP15

TERMINALS	VOLTAGE
L1A & B TO N	120 VAC ALL THE TIME
DLB TO BAKE DLB TO BROIL	240 VOLTS when oven is calling for heat (BAKE & BROIL relay contacts closed)
OVL1-OVL2	120 VAC when light is off
AUX1 - N	120 VAC locking or unlocking

Model JCKP18

TERMINALS	VOLTAGE
L1-N	120 VAC ALL THE TIME
N to COM, COM 0,C	120 VAC ALL THE TIME
L1-1 & 2-BAKE 1 L1-1 & 2-BROIL1 L1-1 & 2 CONV 1	240 VOLTS when oven is not calling for heat (BAKE, CONV. , & BROIL relay contacts open).
L1 to Con P101 Term, 1 & 3	120 VOLTS when light is on.
L1 TO MDL 1	120 VOLTS locking or unlocking
L1-to CON P101 Term 5 & 6 (See Conv. Fan Assy.)	120 VOLTS when oven door is closed and Conv. Bake, Conv. Roast not operating.

Model JKP15

TERMINALS	VOLTAGE
L1A & B TO N	120 VAC ALL THE TIME
L1A & B TO BAKE L1A & B TO BROIL	240 VOLTS when oven is not calling for heat (BAKE & BROIL relay contacts open)
OVL1-OVL2	120 VAC when light is off
AUX1 - N	120 VAC locking or unlocking

Models ZEK937 and JKP18

TERMINALS	VOLTAGE
L1-N	120 VAC ALL THE TIME
N to COM	120 VAC ALL THE TIME
L1-1 BAKE-1 L1-1 BROIL-1 L1-1 CONV-1	240 VOLTS when oven is not calling for heat (BAKE, CONV. , & BROIL relay contacts open).
L1 to Con P101 Term, 1 & 3	120 VOLTS when light is on.
L1 TO MDL 1	120 VOLTS locking or unlocking
L1-to CON P101 Term 5 & 6 (See Conv. Fan Assy.)	120 VOLTS when oven door is closed and Conv. Bake, Conv. Roast not operating.

Key Panel Test

The key panel is connected to the control by a ribbon connector. The control will sound a tone when any of the pads are depressed except for the +/- pads.

To help isolate a problem to either the control or key panel, depress each pad on the key panel followed by the Clear / Off pad and observe the following:

- Bake, Broil, Clean, Timer, Clock, Stop Time, and Cook Time Modes - Audible tone plus display showing mode of operation selected.

Model JKP27

TERMINALS	VOLTAGE
L1A, & B - N	120 VAC ALL THE TIME
AUX1	120 VAC ALL THE TIME
L1A & B TO BAKE L1A & B TO BROIL	240 VOLTS when oven is not calling for heat (BAKE & BROIL relay contacts open)
OVL2 - L1	120 VAC when light is on
AUX2 - N	120 VAC locking or unlocking

Models ZEK957, JKP56, and JKP45

TERMINALS	VOLTAGE
L1-N	120 VAC ALL THE TIME
N to COM, COM 0,C	120 VAC ALL THE TIME
L1-1 & 2-BAKE 1 & 2 L1-1 & 2-BROIL 1 & 2 L1-1 & 2 CONV 1 & 2	240 VOLTS when oven is not calling for heat (BAKE, CONV. , & BROIL relay contacts open).
L1 to Con J6 Term, 1 & 3	120 VOLTS when light is on.
L1 TO MDL 1 & 2	120 VOLTS locking or unlocking
L1-to CON J6 Term 5 & 6 (See Conv. Fan Assy.)	120 VOLTS when oven door is closed and Conv. Bake, Conv. Roast not operating.

Model JKP85

TERMINALS	VOLTAGE
L1 TO N	120 VAC ALL THE TIME
L1 TO BAKE L1 TO BROIL	240 VOLTS when oven is not calling for heat (BAKE & BROIL relay contacts open)
LAMP-L1	120 VAC when light is on
MOTOR 1-MOTOR 2	120 VAC Not locking or unlocking, door closed.

Model JCKS05

TERMINALS	VOLTAGE
L1A & B TO N	120 VAC ALL THE TIME
DLB TO BAKE DLB TO BROIL	240 VOLTS when oven is calling for heat (BAKE & BROIL relay contacts closed)
OV1 - OV2	120 VAC when light is off

Model JKS05

TERMINALS	VOLTAGE
L1A & B TO N	120 VAC ALL THE TIME
L1A & B TO BAKE L1A & B TO BROIL	240 VOLTS when oven is not calling for heat (BAKE & BROIL relay contacts open)
OV1 - OV2	120 VAC when light is off

- Clear / Off - Audible tone and display shows time of day.
- +/- Pads - No audible tone. Can only be used after another function pad has been selected.

If some of the pads work and some don't, the problem is probably with the key panel. To verify that the key panel is the problem, check the connector for proper insertion of the ribbon cable and perform the Ohmmeter Test. If the ohmmeter reads infinity W when depressing the pad, or shows some resistance without depressing the pad, the key panel is bad.

Ohmmeter Test

If some of the pads work and some don't, the problem is probably the key panel. To verify that the key panel is the problem, perform the Ohmmeter Test. If the ohmmeter reads infinite ohms when depressing the pad, or shows less than 1 MEG OHM without depressing the pad, the key panel is bad. The ohmmeter should read under 200Ω when pressing a pad.

Set the ohmmeter on the scale that reads approximately 500Ω. Connect leads to ribbon cable as indicated in chart for each function. Depress function pad. Meter should read less than infinity ohms if the switch contact is working.

Note: Conductors are not all on the same side.

Note: Replacement touch pads come as part of the control panel.

Models JKP27, JKP15, JCKP15, JKS05 and JCKS05

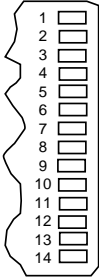

Function	Pins
Bake	12 to 14
Broil	11 to 14
Oven Light	9 to 13
Cooking Time	11 to 13
Delay Start Time	12 to 13
Kitchen Timer	10 to 14
Clock	10 to 13
Clear/Off	3 to 4
Clean	9 to 14

NOTE: Replacement touch pads come as part of the Control panel.

Start	1 to 2
Up Temp	6 to 13
Dn Temp	6 to 14
Up Hour	7 to 13
Dn Hour	7 to 14
UP Min	8 to 13
Dn Min	8 to 14

Model JKP85

Function	Pins
Bake	11 to 13
Broil	10 to 13
Oven Light	11 to 14
Cooking Time	12 to 10
Delay Start Time	11 to 13
Kitchen Timer	9 to 13
Clock	9 to 12
Clear/Off	3 to 4

Start	1 to 2
1	14 to 9
2	8 to 14
3	5 to 13
4	5 to 12
5	6 to 13
6	6 to 12
7	7 to 14
8	7 to 12
9	7 to 13
0	10 to 14

Models JKP18 and JCKP18

FUNCTION	PINS	FUNCTION	PINS	FUNCTION	PINS
Bake	3 to 4	Conv. Roast	2 to 10	0	2 to 8
Broil	1 to 4	Probe	3 to 11	Proof	2 to 7
Clean	2 to 11	1	3 to 6		
Oven Light	1 to 11	2	3 to 5		
Cooking Time	1 to 10	3	3 to 8		
Delay Start Time	3 to 10	4	3 to 7		
Kitchen Timer	1 to 9	5	1 to 6		
Clock	3 to 9	6	1 to 5		
Clear/Off	13 to 14	7	1 to 8		
Start	12 to 14	8	2 to 6		
Conv. Bake	2 to 4	9	2 to 5		

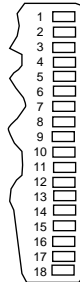

Model JKP45

FUNCTION	UPPER OVEN	LOWER OVEN
	CONDUCTOR	CONDUCTOR
Bake	2 — 14	10 — 14
Broil	2 — 13	10 — 13
Cooking Time	1 — 13	9 — 13
Delay Start Time	1 — 14	9 — 14
Clean	3 — 14	11 — 14
Oven Light	3 — 13	11 — 13
Start	16 — 19	18 — 19
Clear	15 — 19	17 — 19
Temp Up	6-14	8-14
Temp Down	5-14	7-14



COMMON FUNCTIONS

Timer	4 — 13
Clock	4 — 14
Hour Up	6 — 14
Hour Dn	5 — 14
Min Up	8 — 14
Min Dn	7 — 14

Models JKP56 and ZEK957

FUNCTION	UPPER OVEN	LOWER OVEN
	CONDUCTOR	CONDUCTOR
Bake	2 — 14	10 — 14
Broil	2 — 13	10 — 13
Conv. Bake	2 — 13	10 — 12
Conv. Roast	1 — 12	9 — 12
Cooking Time	1 — 13	9 — 13
Delay Start Time	1 — 14	9 — 14
Clean	3 — 14	11 — 14
Probe	3 — 12	11 — 12
Oven Light	3 — 13	11 — 13
Start	16 — 19	18 — 19
Clear	15 — 19	17 — 19

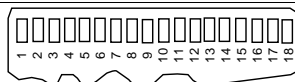

COMMON FUNCTIONS

Timer	4 — 13	5	6 — 13
Clock	4 — 14	6	5 — 13
1	6 — 14	7	8 — 13
2	5 — 14	8	6 — 12
3	8 — 14	9	5 — 12
4	7 — 14	0	8 — 12

ERC Failure Codes

The oven may stop operating but not give an F-code on the display immediately. F-codes are stored in nonvolatile EEPROM until 2 identical faults occur consecutively. After that, the F-code will be displayed. They can be recalled by pressing

together: TIMER, CLOCK, MIN DOWN or 9. While displayed, pressing MIN UP or 8 and HR DOWN or 6 together will clear them. A fault must exist continuously for 5 minutes before an F-code is recorded (F2, F8 are sooner).

Models ZEK957, JKP56, JKP45, JCKP18, and JKP18

FAILURE CODE	MEANING	CORRECTION
F0	Shorted OFF key	Determine if problem is with Key Panel or Control by disconnecting ribbon cable and measuring flat cable pins 13-14. Should be open. Should be 100-150 ohms while pressing OFF key.
F2	Overtemperature 1. Inside oven cavity as measured by sensor over 650°F unlatched or 915°F latched 2. Cooling fan stall while oven above 650°F-open thermal switch in yellow leads.	<ul style="list-style-type: none"> • Welded relay contacts • Cooling fan stalled or blocked • Air flow to rear of unit • High resistance in oven sensor leads/connectors (especially at sensor in rear)
F3	Open oven sensor (Over 2900 ohms)	<ul style="list-style-type: none"> • Disconnect power. Disconnect sensor harness from control. Measure sensor resistance (white leads) to be ~1080 ohms at room temperature with 2 ohms per deg change. • Look for damaged harness terminals if not a bad sensor.
F4	Shorted oven sensor (under 950 ohms)	<ul style="list-style-type: none"> • Disconnect power. Disconnect sensor harness from control. Measure sensor resistance (white leads) to be ~1080 ohms at room temperature with 2 ohms per deg change. • Separate sensor from harness to determine fault.
F5	Sensor Circuit supervisor Failure	Replace Control.
F7	Shorted matrix or START key	Determine if problem is with Key Panel or Control by disconnecting ribbon cable and power up control. If no F code problem is with key circuit.
F8	EEPROM data shift failure.	If repeated, replace control.
F9	Cooling fan stall while oven above 650°F. open thermal switch in yellow leads	Cooling fan or air flow to control area.

Models JKP27, JCKP15, JKP15, JCKS05, and JKS05

FAILURE CODE	MEANING	CORRECTION
F0	Shorted OFF key	Determine if problem is with Key Panel or Control by disconnecting ribbon cable and measuring flat cable pins 13-14. Should be to probe side with conductor. Should be 125-1750 ohms while pressing OFF key.
F2	Over temperature Inside oven cavity as measured by sensor over 650°F unlatched or 915°F latched.	<ul style="list-style-type: none"> • Welded relay contacts • Cooling fan stalled or blocked • Air flow to rear of unit • High resistance in oven sensor leads/connectors (especially at sensor in rear)
F3	Open oven sensor (over 3000 ohms)	<ul style="list-style-type: none"> • Disconnect power. Disconnect sensor harness from control. Measure sensor resistance (white leads) to be ~1080 ohms at room temperature with 2 ohms per deg change. • Look for damage harness terminals if not a bad sensor.
F4	Shorted oven sensor (under 950 ohms)	<ul style="list-style-type: none"> • Disconnect power. Disconnect sensor harness from control. Measure sensor resistance (white leads) to be ~1080 ohms at room temperature with 2 ohms per deg change. • Separate sensor from harness to determine fault.
F5	Sensor Circuit supervisor Failure	Replace Control.
F7	Shorted matrix or START key	Determine if problem is with Key Panel or Control by disconnecting flat cable and measuring cable pins using pinout chart. Allow up to 1000 OHMS when pressing a key.
F8	EEPROM data shift failure.	If repeated, replace control.
F9	Cooling fan stall or other cause of open thermal switch in yellow latch leads.	Suspect cooling fan (between ovens) or air flow.

FAILURE CODE	MEANING	CORRECTION
-F0- -F7-	Stuck key pad May mean relay is turned on.	Determine if problem is with the Key Panel or Control by: 1. Pushing CLEAR/OFF pad, 2. Disconnecting Ribbon Cable from control and waiting at least 3 minutes to see if Code recurs. • If code recurs, problem is in the control. Replace control. • If code does not recur problem is with the Key Panel.
-F2-	Indicates that oven is over temperature in one of the following modes within either a cooking or clean mode of operation. • Control senses oven temperature above 615°F with the door circuit in the unlock mode. • Control senses oven temperature above 915°F with the door in the door locked mode.	<ul style="list-style-type: none"> • Look for welded relay contacts. (Heating elements on in off mode). • Look for high resistance in the sensor circuit due to high contact resistance (poor terminal crimp, deformed terminals, loose connection inside sensor tube) or intermittent solder joint. • Electrical noise interference in the sensor circuit (Ham radio, cordless phone, etc.).
-F3- -F4-	Open or shorted sensor (circuit). Could be a result of contamination on terminals or pinched wire in sensor circuit, cold solder joint on control.	<ul style="list-style-type: none"> • Disconnect power to range. Disconnect sensor connector from control. • Measure sensor resistance at control connector (take care not to damage terminals. Should read 1100Ω at room ambient (approx. 72°F).
		<ul style="list-style-type: none"> • Measure each sensor lead from connector block to ground. If shorted, look for pinched or cut wire in sensor circuit. • Check connector terminals - Look for deformed or corrosion on terminals. Repair or replace. • If all above is ok replace control.
-FF-	Loss of door motor safety circuit.	Replace control.

NOTE: Connections can be intermittent due to a corrosive buildup between the connection to the terminals, or by being bent by the insertion of a probe, etc.

Special Functions

The control has a section that can be entered to change how the control will work. To enter this section, press and hold **BAKE and BROIL** pads for 2 seconds. **SF** appears in the display. Select the area to change. When the change has been made, press **START** to return to Time of Day.

- **End-of-Cycle Tone** - Press **TIMER** pad.
*Display shows **Con Beep** when control is set for Continuous End-of-Cycle Tone or **Beep** when set for Noncontinuous.
- **°F or °C** - Press **Broil** pad. *Display will show either **F** or **C**. Press **Broil** pad again to change.
- **12 hour, 24 hour, or blank out Time of Day Clock** - Press **Clock** pad. *Display will show **12 hr, 24 hr, OFF** for blank clock. Press again to change.
- **Cook & Hold** (used only with Time Bake or Delay Bake functions) - Press **Cooking Time** pad. *Display will show either **Hld On** or **Hld Off**. Press again to change.
- **Child Lockout** - Press **CLEAN**. *Display will show **Loc On** (when any heating functions are tried, display will show **Off**). Press **CLEAN** again for **Loc Off**, control unlocked.
- **12-hour shutdown** comes set to shut down after 12 hours of continuous operations; this can be eliminated - Press **Delay Start** pad. *Display will show **No Shdn**. To turn back on, press **Delay Start** pad again and display will show **12 Shdn**.

Note: Sabbath is between No Shdn and 12 Shdn.

- **Sales Mode** (special feature added for sales floor demonstration) - Press **Clock** and **Timer** pads at the same time. *Display will start to cycle through the different modes of operation.
- **Sabbath Mode** (GE models only) disables all but bake, timebake, no beeps, and 12h shut-down override, and puts symbols on red display during bake. Access by pressing **Delay Start** pad until display shows **Sabbath**. Exit by pressing **Delay Start** pad until **No Shdn** or **12 Shdn** shows.

Oven Sensor and Sensor Circuits

The control monitors the oven temperature through the oven temperature sensor. The sensor on these models is located on the upper left corner of the rear oven wall. To access, remove 2 screws and pull the wire and the connector through the oven back.

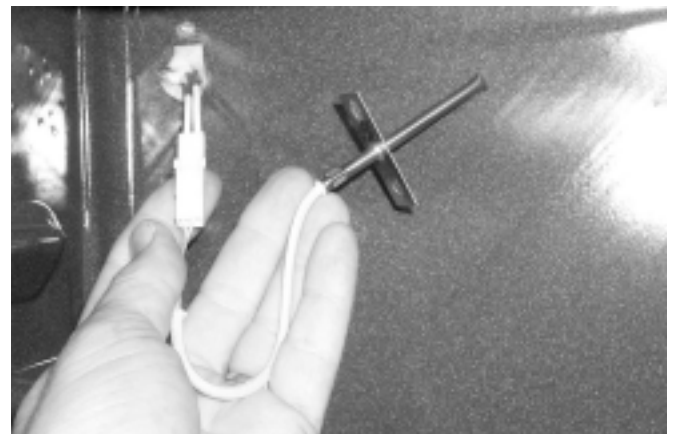
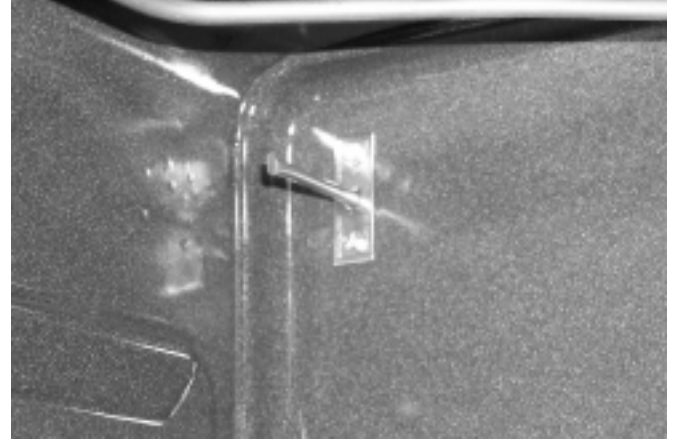

Oven Sensor and Door Switch Ohmmeter Test

See **Motorized Door Lock Operation**, page 26, for door switch function explanation.

Disconnect power to range. Make resistance measurement from side of sensor and lock switch connector with exposed terminals.

Model JKP85

CIRCUIT	TERMINALS	OHMS
Oven Sensor		*1100Ω@Rm Temp. 2562Ω@ 825°F Clean
Door Unlatched	Common-unlock	0Ω
Door Latched	Common-lock	Open
	Common-unlock	Open

Models ZEK957, JKP56, and JKP45

CIRCUIT	TERMINALS		OHMS
	UPPER OVEN	LOWER OVEN	
Oven Sensor	6 to 8	3 to 4	*1100Ω@Rm Temp.
Door Unlatched	3 to 5	6 to 8	0Ω
	4 to 5	6 to 7	Open
Door Latched	4 to 5	6 to 7	0Ω
	3 to 5	6 to 8	Open

Models ZEK937, JKP18, and JCKP18

CIRCUIT	TERMINALS	OHMS
	UPPER OVEN	
Oven Sensor	6 to 8	*1100Ω@Rm Temp.
Door Unlatched	3 to 5	0Ω
	4 to 5	Open
Door Latched	4 to 5	0Ω
	3 to 5	Open

Models JKP27, JKP15 and JCKP15

CIRCUIT	TERMINALS	OHMS
Oven Sensor	4 to 6	*1100Ω@Rm Temp. 2562Ω@ 825°F . Clean
Door Unlatched	1 to 3	0Ω
	2 to 3	open
Door Latched	2 to 3	0Ω
	1 to 3	open

Models JKS05 and JCKS05

CIRCUIT	TERMINALS	OHMS
Oven Sensor	4 to 6	*1100Ω@Rm Temp.

* If abnormal reading is observed, remove sensor from oven and check at disconnect block. Wiggle leads while checking resistance. If more than 10Ω, replace sensor.

Sensor and Lock Switch Connectors

Models ZEK957, JKP56, and JKP45

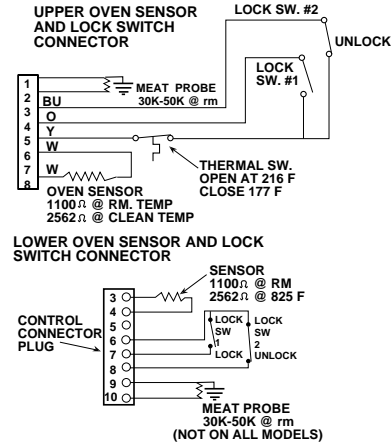

Model JKP85

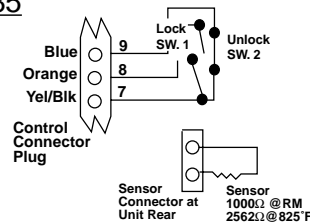

Models JKP27, JKP15, and JCKP15

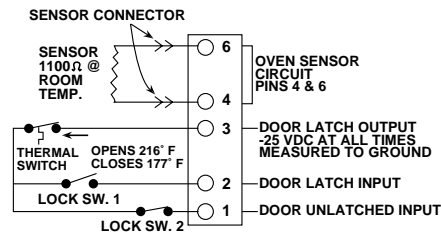

Models ZEK937, JKP18, and JCKP18

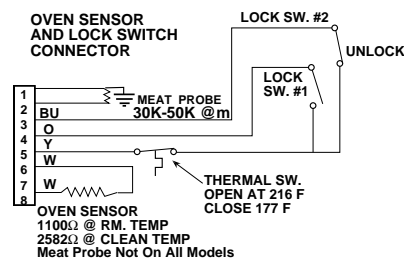

Model JCKS05

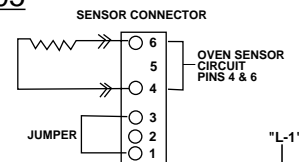

Model JKS05

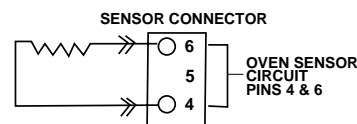

Oven Circuits

* Bake and broil units cannot be on at the same time.

- Bake and Broil units time-share during and after preheat. There is approx. 1 minute of dead time between Bake and Broil operation while calling for heat after preheat.
- Broil & Clean unit only on during first 30 minutes or until oven reaches 750 °F. During the balance of the Clean operation, the oven will cycle between the Bake and Broil units.

**Convection fan not running, make the following checks:

- Check the voltage from terminal P101-5 or -6 on control. Voltage should read 120 V in Conv. Bake or Roast mode.
- If voltage OK, check convection fan motor. It should read approx. 15-20 V at room temperature. Check to ensure shaft is not rubbing on the oven liner.

Oven Calibration

Testing has shown that this oven has the best cooking performance at a control setting of 350 °F when the **AVERAGE** center oven temperature is between 340 °F and 380 °F (depending on model). Customers may change the average center oven temperature by +/- 35 °F to satisfy their own cooking needs.

To change:

- Press and hold **Bake & Broil** pads until **SF** appears in display.
- Press **Bake** pad to enter oven calibration mode (separate for upper and lower). A number between +35 °F and -35 °F will be displayed.
- Press **TEMP** Up or Down or digit pads (depending on model) to change average oven temperature. (Use **Bake** pad to switch between + or - settings, if using digit pads.)
- Press **START** to return to Time of Day.

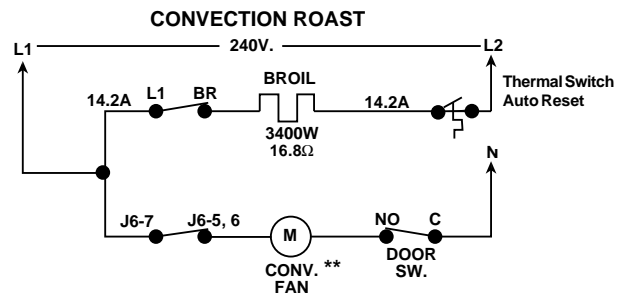
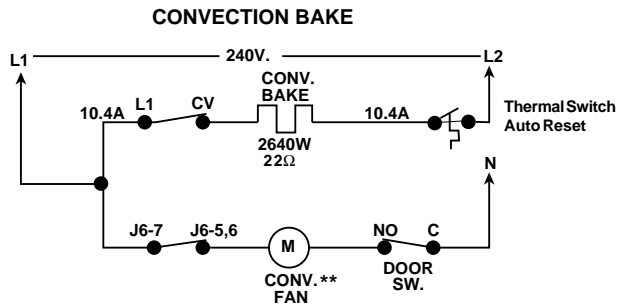
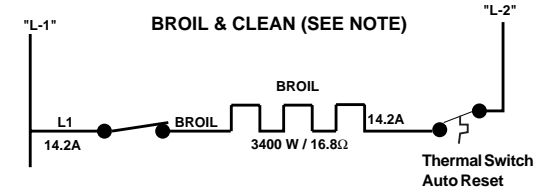
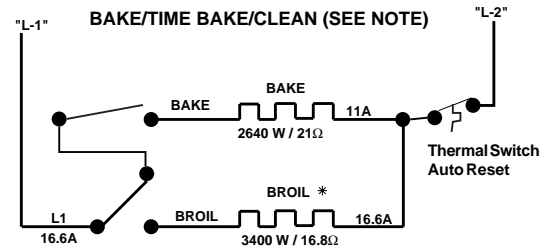

Set Point Table	SET POINT	DOT	PART NO.
Single Wall Ovens			
Lock Thermal SW NC	88° C/190° F	White	326B1152P008
Fan Thermal SW NO	59° C/138° F	None	229C4869P005
Thermal Cutout NC	166° C/330° F	Orange	SWC144
Double Wall Ovens, Upper			
Lock Thermal SW NC	118° C/240° F	Orange	229C4870P004
Fan Thermal SW NO	59° C/138° F	None	229C4869P005
Thermal Cutout NC	166° C/330° F	Orange	SWC144
Double Wall Ovens, Lower			
Lock Thermal SW NC	185° C/385° F	Red	205C2685P002
Fan Thermal SW NO	59° C/138° F	Purple	205C2686P001
Thermal Cutout NC	121° C/250° F	Blue	SWC065
Microwave Double Ovens			
Lock Thermal SW NC	178° C/349° F	Green	205C268P001
Fan Thermal SW NO	59° C/138° F	Purple	205C2686P001
Thermal Cutout NC	121° C/250° F	Blue	SWC065

Motorized Door Lock

The motorized door lock assembly is located above the oven. The assembly consists of a lock motor cam and switch assembly, lock hook, heat barrier, and mounting plate.

Access to this assembly, for single and upper ovens, is behind the control panel. For lower ovens, access is behind the trim cover between the 2 ovens.

Motorized Door Lock Operation

The lock motor is energized when the control is set for Clean and Clean Time selected. The K1 relay contact will close and complete the circuit that supplies the voltage to the lock motor.

Note: The display of the Control will flash LOCK DOOR if the door switch is in the C to NC position (Door open).

The words LOCKED DOOR will flash on and off in the display while the lock motor is in motion. When the door is locked the words LOCKED DOOR remains illuminated in the display.

The cam on the motor performs two functions:

1. Positions the lock hook in the door to prevent opening during Clean operation.
2. Operates the lock switches that tell the control if the door is unlocked or locked and ready for Clean operation.

Note: When door is either being locked or unlocked, both lock switches will be in the open position.



Single & Upper Oven

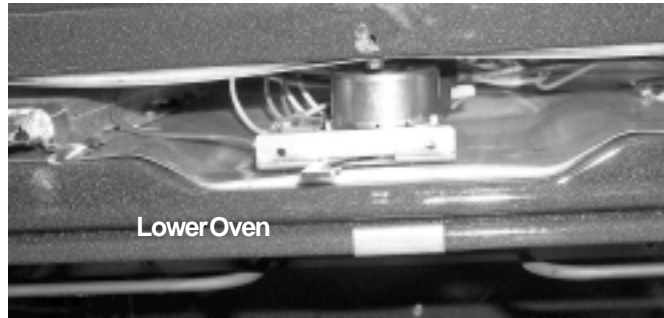

Lower Oven

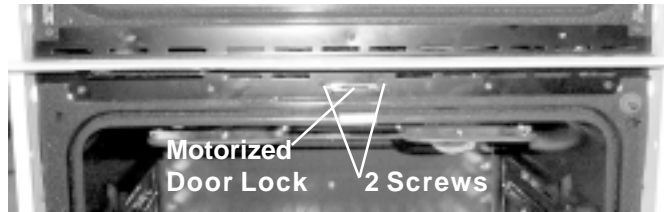

Motorized Door Lock 2 Screws

Note: For lower oven, when assembling, attach the motorized door lock assembly to the trim cover and assemble as a unit.

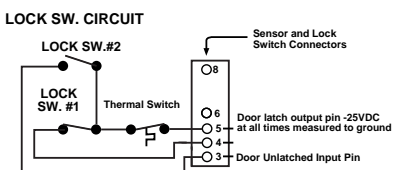

Locked

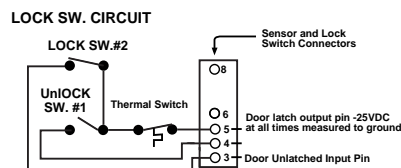

Unlocked

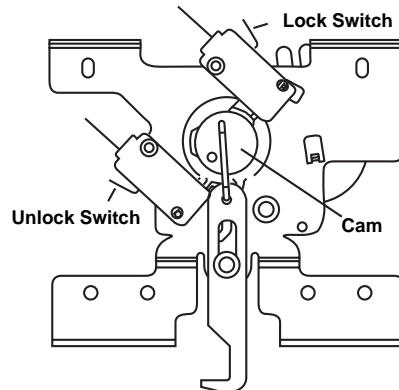
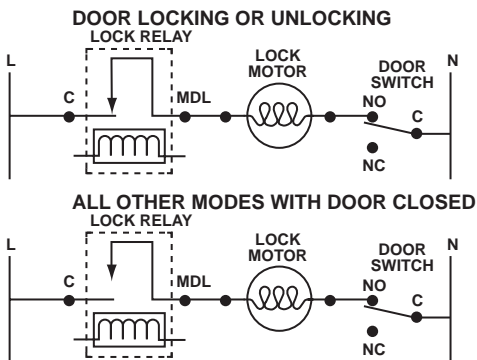
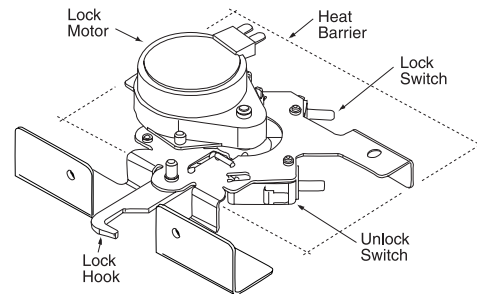

Oven Thermal Switch

A self-resetting, disc-type thermal cutout switch is mounted to the rear of the oven. The switch will open the L2 leg of the power to the heating elements in the event of an overtemperature condition. Single and lower oven switch opens at 250 °F. Upper oven switch opens at 330 °F. All switches close at 220 °F.

There is no indication to the customer when the switch opens or closes.

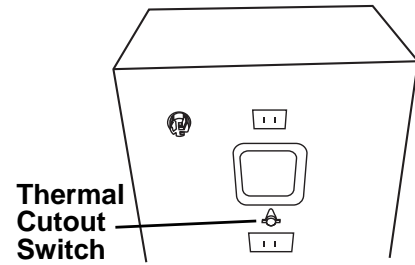

Note: Oven must be removed from installation for access to the thermal cutout switch.

Lock Thermal Switch

A thermal switch is in the lock switch circuit in the normally closed position.

The single wall oven switches and upper and lower double wall oven switches open at 216 °F and automatically close when temperatures cool below 177 °F. The lower oven switch of the microwave wall oven (JKP85) opens at 240°F and automatically closes when the temperature cools below 190 °F.

If the thermal switch opens during:

1. Oven Temperature Below 600 °F. Program is cancelled when thermal switch opens. Lock motor will run and the words LOCKED DOOR will be flashing in the display.
2. Oven Temperature Above 600 °F. Any mode of operation control will go to -F9- or -F2- failure code. When this condition exists, check the fan operation (look for obstructions), and inspect oven installation (make sure grill areas are not blocked), oven insulation, and lock circuit.

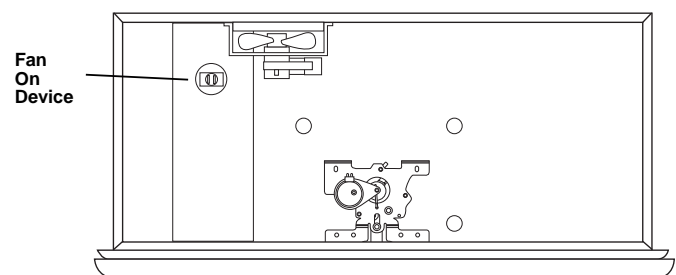
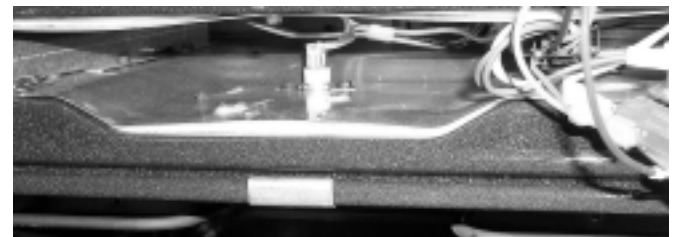
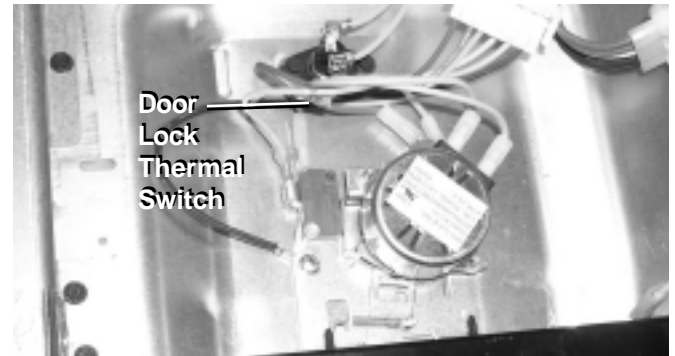

Fan Switch

The fan switch is a self-resetting switch located on the vent box. The switch will turn the fan on in any mode of operation when it detects a vent temperature above 138 °F. The fan will turn off once it has cooled below 106 °F.

Note: To access the lower oven fan switch, the oven must be removed from the installation, and the upper oven must be removed from the lower oven.

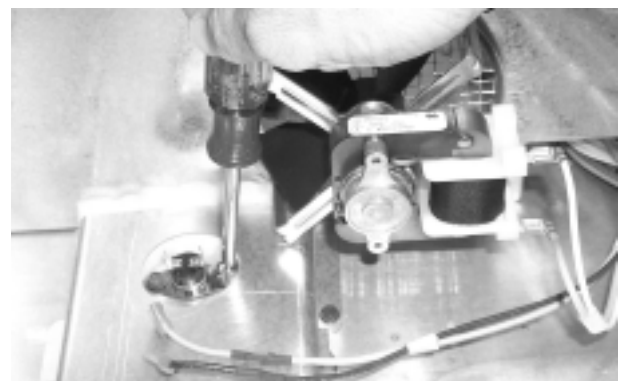

Convection Bake Element and Fan Assembly

The convection bake element and fan assembly are located on the back wall of the oven liner behind the panel with the screen in the center.

To access convection bake element:

1. Disconnect the power to range; remove the oven door and the oven racks.
2. Remove 4 screws from the mounting panel (2 on each side) and pull forward.

To remove convection bake element:

Remove 3 screws mounting the element to the back wall and pull forward. Disconnect the wires.

To service fan:

Note: Convection fan blade nut has left-handed threads.

Fan blade can be replaced from inside oven.

Oven must be removed from installation to access convection fan motor.

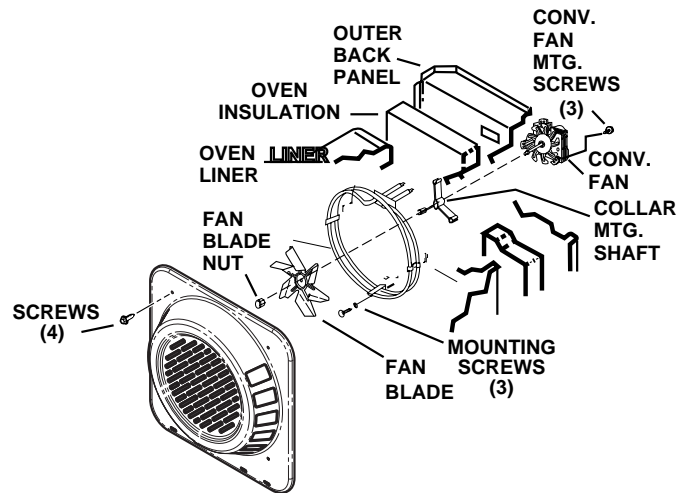

Microwave

WARNING:
DISCONNECT POWER BEFORE SERVICING.
Reconnect all grounding devices.

All parts of this appliance capable of conducting electrical current are grounded. If ground wires, screws, straps, clips, nuts, or washers used to complete a path to ground are removed for service, they must be returned to their original position and properly fastened.

Precautions to be observed before and during servicing to avoid possible exposure to excessive microwave energy:

- A.** A microwave emissions check should be performed prior to servicing if oven is operative.
- B.** Do not operate or allow the oven to be operated with the door open.
- C.** If the oven operates with the door open:
 - 1) Instruct the user not to operate the oven.
 - 2) Contact the manufacturer and the center for devices and radiological health immediately.
- D.** Make the following safety checks on all ovens to be serviced before activating the magnetron or other microwave source. Make repairs as necessary.
 - 1) Interlock operation
 - 2) Proper door closing
 - 3) Seal and sealing surfaces (arching, wear, and other damage)
 - 4) Damage to and loosening of hinges and latches
 - 5) Evidence of dropping or abuse
- E.** Before turning on microwave power for any test or inspection within the microwave generating compartments, check the magnetron, wave guide or transmission line, and cavity for proper alignment, integrity, and connections.
- F.** Any defective or misadjusted components in the interlock, monitor, door seal, and microwave generation and transmission systems shall be repaired, replaced, or adjusted by procedure described in this manual before the oven is released to the owner.
- G.** A microwave leakage check to verify compliance with the federal performance standard should be performed on each oven prior to release to the owner.

Microwave Removal

The microwave is fastened to the top of the lower oven by 2 screws in the front and metal tabs in the rear which insert into slots in the unit's frame. The microwave can be easily removed from the lower oven without removing the unit from the wall.

To remove the microwave:

1. Open the lower oven door and remove 3 screws from the bottom of the trim.
2. Open the microwave door and remove 2 T-15 torx screws and the trim.
3. Disconnect the wiring connectors under the microwave.
4. Remove 2 screws from the front of the 2 mounting tracks.
5. Slide the microwave out of the unit.



Microwave Outer Case Removal

To remove the outer case:

1. Remove the microwave from the oven.
2. Remove 1 screw and the exhaust vent cover.
3. Remove 8 screws and the air tunnel.
4. Remove 1 screw from each trim mounting bracket.
5. Remove the screws from the right side panel. Lift up to release the upper tabs from the chassis and remove the panel.
6. Remove 2 screws from the left side of the case and 2 screws from the back of the case.
7. Slide the case back to separate the case tabs from the chassis and remove.

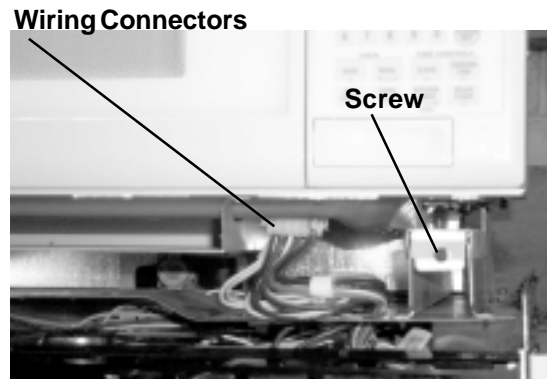

Microwave Door

The door is serviced by replacing the outer door parts or by replacing the complete door.

To remove the door:

1. Remove 2 bolts holding the upper and lower door hinge to the oven.
2. Carefully open the door and, while moving the door toward you, work the upper hinge out through the opening in the oven.

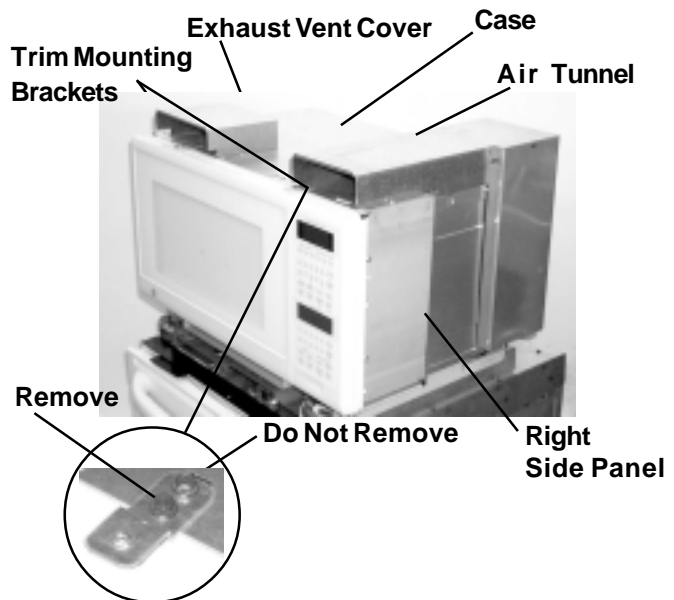

3. Place the door on its front. At the latch opening, insert a small screwdriver into the gap between the metal inner door frame, attached around the door circumference, and the viewing surface. Pry up to disengage the hooks for removal.
4. To mount the door to the oven, first install the hinge bolts finger tight, then push the door lightly against the oven. Make sure the door is parallel to the outline of the oven and tighten the bolts.
5. Check latch lever operation at strike assembly. Adjust if necessary.

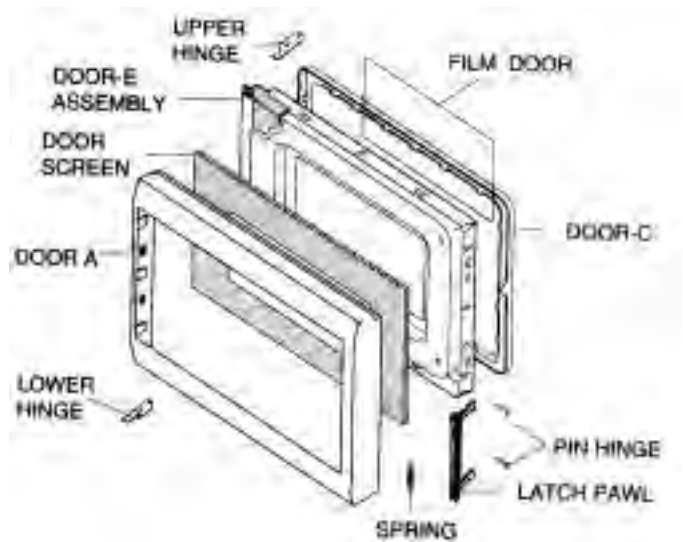

Microwave Control Panel

The control panel is hinged on the bottom, allowing access to the PCB and component compartment when in the service position.

The replaceable parts on the control panel are the oven PCB and microwave PCB. Replacement control panel parts do not come with an oven PCB and a microwave PCB.

To place control panel in service position:

1. Open the oven door and remove 2 torx screws from the left side of the control panel.
2. Pull the inside edge of the control panel out approximately 1 in. and slide the panel to the left to release the 3 locking tabs on the right side of the panel.
3. Lower the panel into service position.

Note: To remove control panel, disconnect connectors and remove 2 Phillips screws at the hinge.

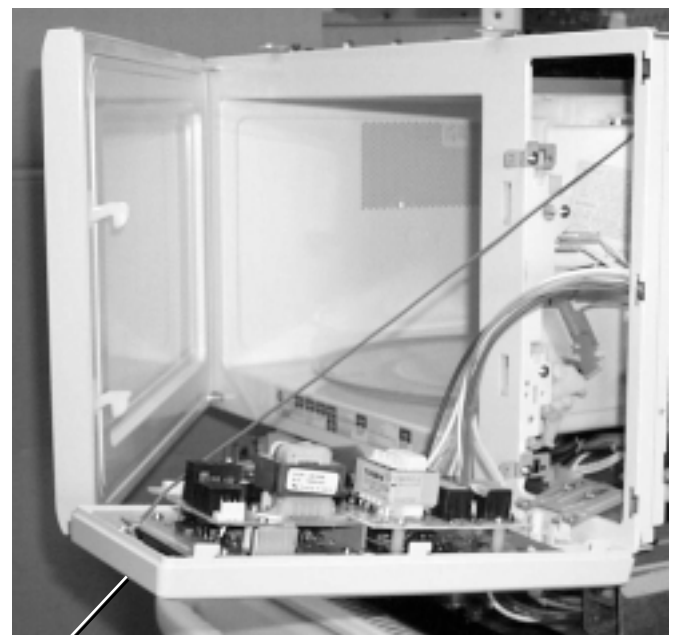
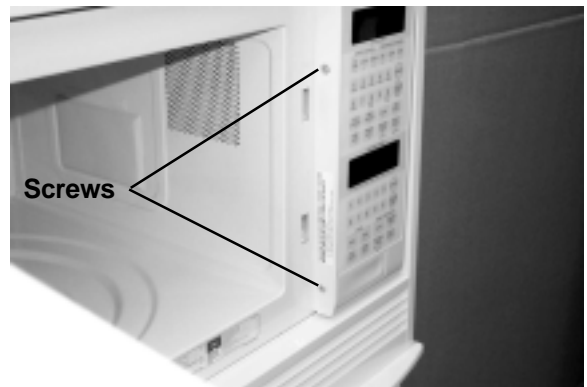

Control Panel in Service Position

Microwave Power Control Board (PCB)

The PCB is mounted to the control panel and can be accessed by placing the control panel in the service position.

To remove the PCB:

1. Place the control panel in the service position.
2. Disconnect the wiring from the PCB.
3. Disconnect the ribbon from the PCB.
4. Remove 4 screws and the PCB.

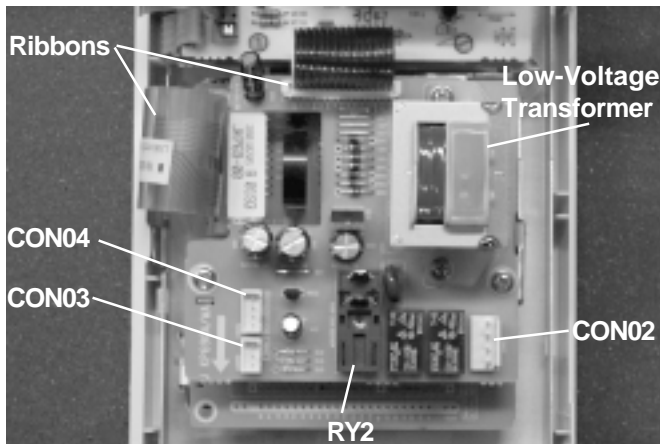

Main PCB Locator Chart			
Connector	Wire Colors	Number of Terminals	Description
CON02	Blue Orange White	3	Mag Fan, Turn Table, Neutral
CON03	Orange	2	Door Sensing Switch
CON04	Red White Black Orange	4	Gas Sensor
RY2	Black Blue	2	Line-in, Fan TCO, High Voltage Transformer, Monitor Switch

Microwave Low-Voltage Transformer

The low-voltage transformer is located on the PCB. If the transformer fails, the PCB must be replaced.

Low-Voltage Transformer Test

Verify 120 VAC is present to primary side of transformer. If 120 VAC is not present, suspect a faulty PCB. If 120 VAC is present, use the chart to check the voltage output of the low-voltage transformer.

If the voltage output or resistance is not correct, replace the PCB.

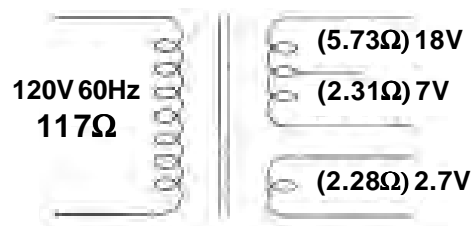

Microwave Key Panel Test

The control panel circuits from the keys to the PCB can be verified by a continuity test.

Refer to the chart in the mini-manual located behind the control panel.

Microwave High-Voltage Capacitor

WARNING: Always be certain the capacitor is discharged before servicing. Mechanically discharge by placing an insulated handle screwdriver between the diode connection of the capacitor and the oven chassis ground.

Note: The high-voltage capacitor has an internal shunt resistor that automatically discharges the capacitor when the oven turns off. Under normal operation, the capacitor should fully discharge within 30 seconds.

The microwave must be removed from the oven to service the high-voltage capacitor.

The high-voltage capacitor is mounted to the base plate at the rear of the component compartment. If the capacitor is open, no high voltage will be available to the magnetron.

High-Voltage Capacitor Test

1. Disconnect the leads and check for short or open between the terminals using an ohmmeter set on high ohm scale. If the capacitor is normal, the meter will indicate continuity for a short period and should indicate an open circuit once the capacitor is charged.
2. If the above is not the case, check for a short between either terminal and the case. If shorted, replace the capacitor.

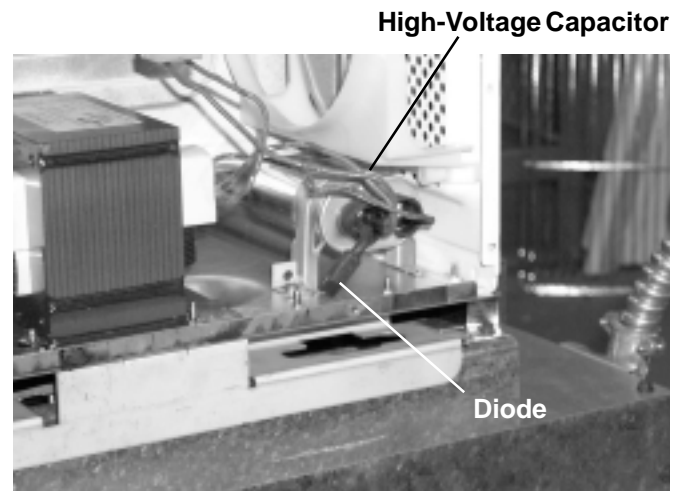

Microwave High-Voltage Diode

The microwave must be removed from the oven to service the high-voltage diode.

WARNING: Discharge the high-voltage capacitor before touching any oven components or wiring.

The high-voltage diode is connected to the high-voltage capacitor and is grounded to the chassis.

High-Voltage Diode Test

To test diode for a short:

1. Isolate the diode from the circuit.
2. Set ohmmeter to diode setting.

Note: Reading may differ with various types and brands of meters.

3. Measure the resistance across the diode. An infinity or +OL reading should appear.

To test diode forward bias:

1. Set ohmmeter to highest ohm setting.
2. Connect the lead from the positive side of the ohmmeter to the negative terminal of a 9 volt battery.
3. Connect the positive diode terminal to the positive terminal of the battery.
4. Connect the common lead of the ohmmeter to the diode ground terminal.

Note: Reading may differ with various types and brands of meters.

Ohmmeter reading should be approximately 1.400 ohms.

To test reverse bias:

1. Set ohmmeter to highest ohm setting.
2. Connect the lead from the positive side of the ohmmeter to the negative terminal of a 9 volt battery.
3. Connect the negative diode terminal to the positive terminal of the battery.
4. Connect the common lead of the ohmmeter to the positive diode terminal.

Note: Reading may differ with various types and brands of meters.

Ohmmeter should read OL.

If a short is indicated in both directions, or if an infinite resistance is read in both directions, replace the diode.

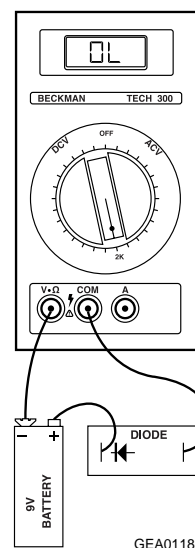
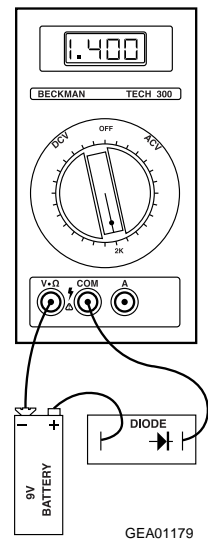
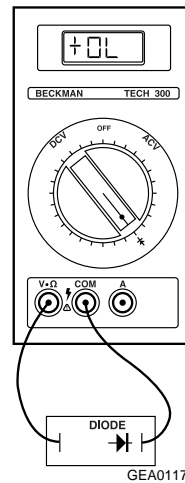

Microwave High-Voltage Transformer

WARNING: Discharge the high-voltage capacitor before touching any oven components or wiring.

The microwave must be removed from the oven to service the high-voltage transformer.

The high-voltage transformer is mounted to the microwave baseplate with 4 Phillips screws.

High-Voltage Transformer Test

1. Disconnect the primary input terminals (white and black wires) and measure the resistance of the transformer with an ohmmeter. Resistance should be less than 1 ohm.
2. Measure the resistance on the high-voltage side of the transformer (terminal 5 to chassis ground).
 - a. Disconnect red/black wire from capacitor.
 - b. Connect ohmmeter between red/black wire and chassis ground.
 - c. Resistance should be between 70 to 110 ohms.
3. Measure the resistance of the filament windings (terminal 4 to 3).
 - a. Disconnect connector from magnetron.
 - b. Connect ohmmeter between terminals of connector.
 - c. Resistance should be less than 1 ohm.

High-Voltage Transformer

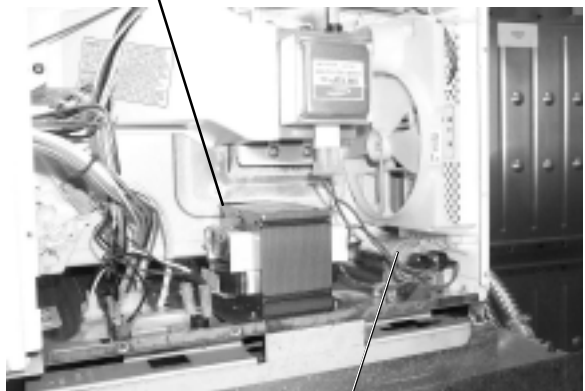

High-Voltage Capacitor

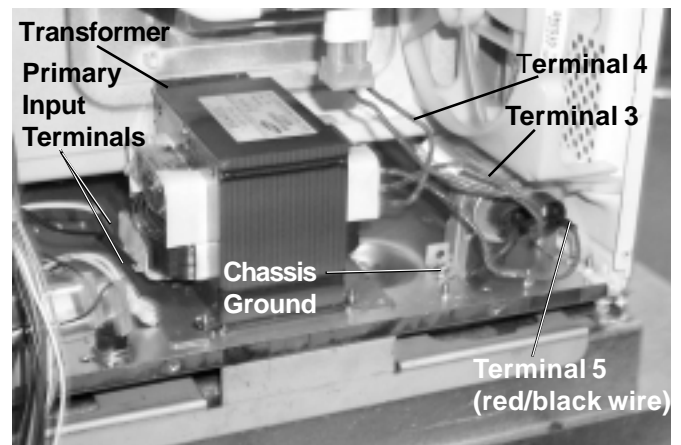

Microwave Magnetron

The microwave must be removed from the oven to replace the magnetron.

WARNING: When replacing the magnetron, be certain the R.F. gasket is in place and mounting screws are tightened securely to the waveguide. Failure to do so can result in hazardous levels of microwave leakage. Perform microwave leakage test.

WARNING: High voltages are present during the cook cycle, extreme caution should be observed. Disconnect oven from power supply and discharge the high-voltage capacitor before touching any oven components or wiring.

The magnetron is mounted in the component compartment with 4 Phillips screws.

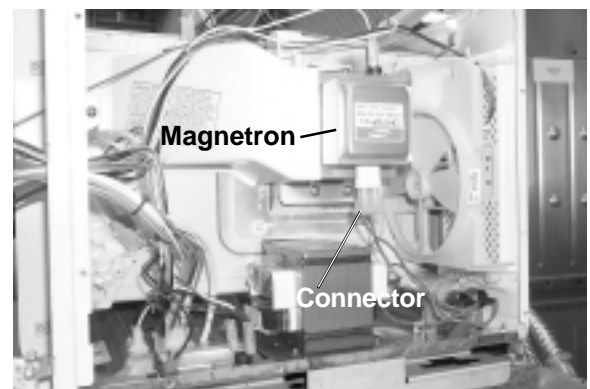

Magnetron Test

1. Isolate the magnetron from the high-voltage circuit by disconnecting the magnetron connector.
2. Check for continuity across the magnetron filament leads with an ohmmeter. Resistance should be less than 1 ohm.
3. Check for continuity between one magnetron filament lead and the chassis ground. This test should indicate an infinite resistance. If there is continuity, the magnetron is grounded and must be replaced.
4. Check for continuity between the other magnetron filament lead and the chassis ground. This test should indicate an infinite resistance. If there is continuity, the magnetron is grounded and must be replaced.

Power output of the magnetron can be measured by conducting a Performance Test (see Microwave Performance Test).

Microwave Magnetron Fan

The microwave must be removed from the oven to service the magnetron fan.

The magnetron fan operates whenever the magnetron is operating. The magnetron fan will also operate if the fan thermal switch reaches 158 °F.

The fan draws external air into the component compartment through holes in the rear panel. The air is circulated through the magnetron air vanes, providing cooling for the magnetron. The air also circulates through the oven cavity to remove steam and vapors given off when heating food.

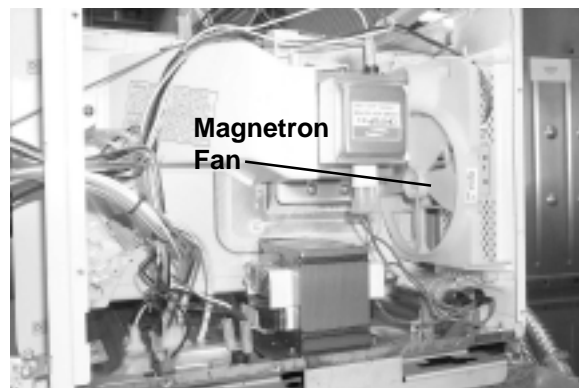

Microwave Magnetron TCO (Thermal Cutout)

Obtain access to the magnetron TCO by placing the control panel in the service position.

OPEN - 302 °F

CLOSE - 140 °F

The magnetron TCO is mounted on the top of the magnetron with 2 Phillips screws. This position allows the TCO to sense the temperature of the magnetron and will open, shutting the unit down if excessive heat (302 °F) is detected. The TCO will

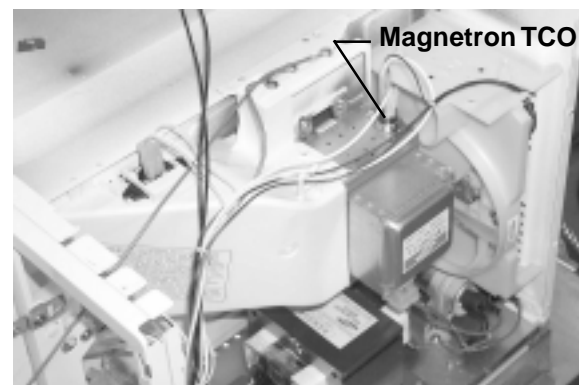

close at 140 °F, restoring function to the unit.

If the magnetron TCO has opened, check for fan failure, obstructed air ducts, or dirty or blocked air intake.

Microwave Fan Thermal Switch

Obtain access to the fan TCO by placing the control panel in the service position.

OPEN - 140 °F

CLOSED - 158 °F

A fan thermal switch is mounted on the microwave baseplate. If, during lower oven use, the baseplate should reach 158 °F, the fan thermal switch will close, activating the magnetron fan. This will assist in removing heat from the component compartment.

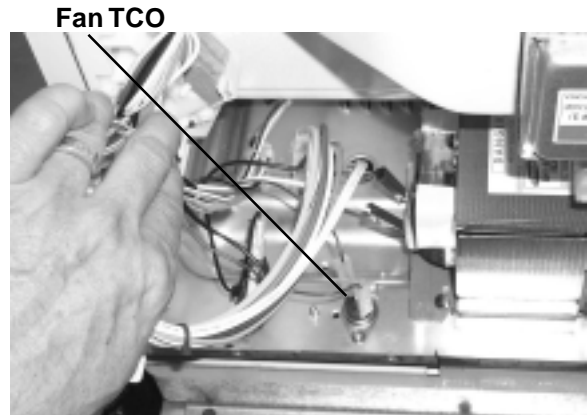

Microwave Fuse

Obtain access to the fuse by placing the control panel in the service position.

Warning: When the 20-amp fuse is blown due to the operation of the monitor switch, the monitor switch must be replaced. Also replace relays and/or interlock switches when continuity check shows contacts shorted.

A 20-amp fuse is connected to the line-in side of the unit's circuitry and is common to all functions and the door switches. If this fuse blows (open), no functions will operate, including the display.

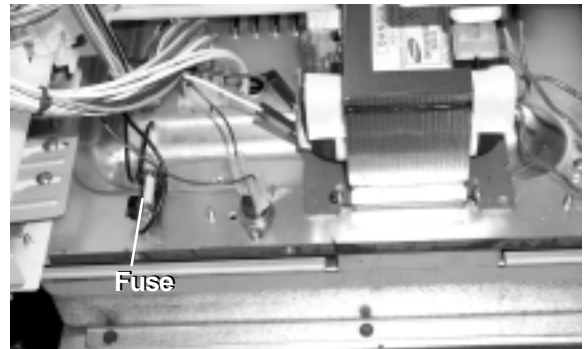

Microwave Flame TCO

The microwave must be removed from the oven to service the flame sensor.

OPEN - 240 °F

The flame TCO is a one-shot, nonresettable TCO mounted to the left side of the oven cavity. In the event the oven temperature reaches 240 °F, the flame TCO will open, automatically shutting the oven off. The flame TCO is connected to the line-in side of the circuit.



Microwave Gas (Humidity) Sensor

The microwave must be removed from the oven to service the gas sensor.

A gas sensor is used in AUTO COOK mode to monitor increasing humidity (steam) and hydrocarbons (food odors) during cooking. When vapor increases in the oven due to cooking, the resistance of the sensor changes. This information is received by the PCB, which adjusts the cooking time to various types and amounts of food.

The gas sensor is located on the outer left side of the oven cavity by the cavity exhaust.

Sensor Test

Caution: Do not attempt to check sensor with ohmmeter. Sensor damage will occur. Only heater terminals (H) can be checked with ohmmeter (30Ω).

1. Place 1/3 cup tap water in microwave.
2. Press the popcorn pad.
3. After 1-2 minutes, the control should beep and the display should begin a countdown.
4. Press CLEAR/OFF pad.
 - a. If sensor fails test, go to step 5.
 - b. If sensor passes test, sensor is OK.
5. Press and hold the 7 and 8 number pads at the same time.
6. Observe the diagnostic number in the display.
 - 15 to 184 - sensor OK.
 - 185 or higher - sensor failed open, sensor unplugged, sensor circuit open, or faulty PCB.
 - Less than 15 - shorted sensor or faulty PCB.

Microwave Interlocks and Monitor

Obtain access to the interlock and monitor switches by placing the control panel in the service position.

The primary interlock, interlock monitor, and door sensing switches are mounted to a plastic latch board on the right side of the cavity. The switches are as follows:

- Primary Interlock

This switch interrupts the circuit to all compo

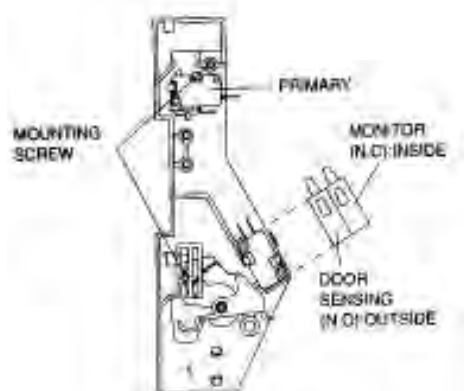
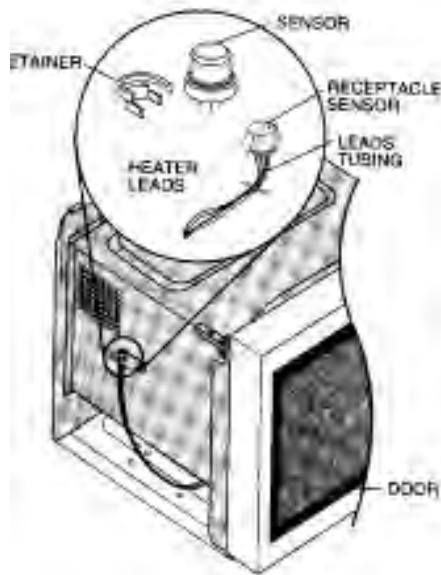

nents, except the oven lamp. A cook cycle cannot take place until the door is firmly closed, thereby activating the interlock switches.

- Interlock Monitor

This switch is intended to render the unit inoperative by means of blowing the fuse when the contacts of the primary interlock switch and power relay fail to open when the door is opened.

- Door Sensing (Secondary Interlock)

This switch and the primary interlock switch will interrupt the circuit before the door can be opened.

Primary Interlock Test

1. Remove the oven and discharge the capacitor.
2. Place the control panel in the service position.
3. Check continuity between switch terminals. Normal readings are as follows:
 - Door closed: 0 ohms
 - Door open: infinite ohms

Door Sensing Switch Test

1. Remove the oven and discharge the capacitor.
2. Place the control panel in the service position.
3. Check continuity between switch terminals. Normal readings are as follows:
 - Door closed: 0 ohms
 - Door open: infinite ohms

Monitor Switch Test

1. Remove the oven and discharge the capacitor.
2. Place the control panel in the service position.
3. Remove one monitor switch lead to isolate the switch.
4. Check continuity between switch terminals. Normal readings are as follows:
 - Door closed: infinite ohms
 - Door open: 0 ohms

Interlock System Test

1. Remove the oven and discharge the capacitor.
2. Check the 20-amp fuse for continuity and proper size. Do not use any other fuse or size except 20 amp (314 type or ABC type).
3. Remove one monitor switch lead to isolate the switch. Check continuity of switch with door open and door closed.
 - Door closed: infinite ohms
 - Door open: 0 ohms
4. Reconnect the switch leads
5. Test the circuit operation:
 - a. Connect a temporary jumper across relay contacts, primary interlock, and door sensing switch to simulate shorted switch contacts.
 - b. Connect the ohmmeter (Rx1) across the line terminals of the appliance cord. Continuity must show:
 - Door closed: Some ohms
 - Door open: 0 ohms
 - c. Remove the 20-amp fuse - circuit must open (infinite ohms). If not, check wiring of monitor and interlocks.
6. After testing is complete, remove temporary jumper leads from interlocks and relay and reconnect switch leads.
7. Replacement of any parts or monitor circuit requires repeating this entire test procedure.

Interlock Adjustment

Warning: A microwave leakage test must be performed any time a door is removed, replaced, disassembled, or adjusted for any reason. The maximum allowable leakage is 4 MW/cm².

The latch board is adjusted for door fit and switch operation.

1. Place the key panel in the service position.
2. Loosen the latch-board mounting screws at the vertical flange.
3. Adjust the latch board for proper switch operation and door fit. Retighten screws.

Microwave Oven Lamp Assembly

The microwave must be removed from the oven to service the oven lamp assembly.

The oven lamp assembly is located in the air duct at the top of the component compartment. The bulb is 25 watts and 125 VAC. To access the oven lamp assembly:

1. Remove the microwave from the oven.
2. Remove the outer case.
3. Unplug the harness connector from the oven lamp assembly.

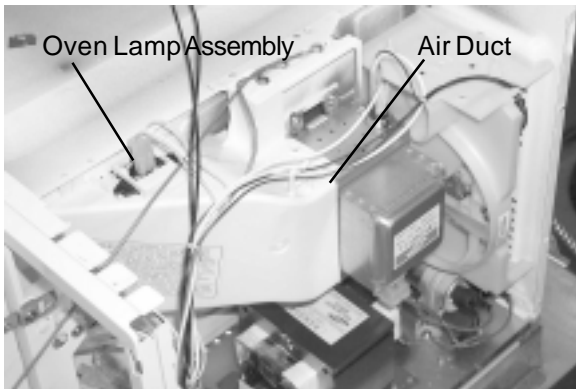

4. Remove 1 screw and the air duct.

Note: The light bulb is not removable from the socket. Replace as a complete assembly.

5. Slide the oven lamp assembly out of the tabs and remove.

Microwave Turntable Motor

The microwave must be removed from its installation to service the turntable motor.

The turntable motor is a 120 VAC motor that is mounted to the bottom of the oven. The turntable motor will operate any time the magnetron is operating.

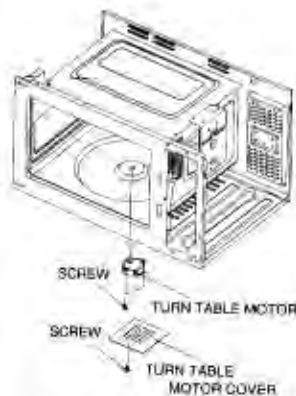

Microwave Performance Test

This test will verify that the microwave oven high-voltage and magnetron circuits are operating to performance specifications.

The standard load is 1 liter (1000 ml) of water with a starting temperature of 59 °F to 75 °F in a 1000-ml beaker (WB64X0073). (Do not use any other load or dish, as results will vary from the standard.)

1. Measure the line voltage (loaded). This test is based on normal voltage variations of 105 VAC to 130 VAC. Low voltage will affect power and temperature rise.
2. Place beaker containing 1 liter of water on glass shelf in the center of the oven and record initial water temperature with an accurate glass thermometer (Robinar no. 12084).
3. Run the microwave on high power setting for 2 minutes, 3 seconds.
4. At the end of the cooking cycle, record the water temperature. The minimum difference between the initial and ending temperatures should be 40 °F @ 120 VAC.

If the water temperature rose but did not reach the 40 °F minimum difference, suspect a problem with the line voltage (test under full load) or magnetron/high-voltage circuit. If the water temperature did not rise at all, suspect a problem in the high-voltage circuit.

Microwave Leak Test

Warning: Maximum allowable leakage is 4 MW/cm². Inform the manufacturer of any oven found to have emission in excess of 4 MW/cm². Make repairs to bring the unit into compliance at no cost to the owner and determine the cause. Instruct the owner not to use the oven until it has been brought into compliance.

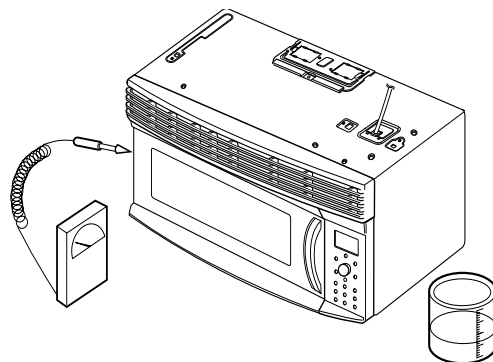

To perform a microwave leak test:

1. Place 275 ml of water in a 600-ml beaker (WB64X5010).
2. Place the beaker in the center of the oven on the turntable.
3. Set the leakage meter to the 2450 MHz scale.
4. Turn microwave on for 5 minutes.
5. Hold the probe perpendicular to the surface being tested and scan surfaces at a rate of 1 inch per second. Scan the following areas:
 - Entire perimeter of door and control panel
 - Viewing surface of door window
 - Exhaust vents

Warning: Maximum allowable leakage is 4 MW/cm².

6. Record data on service invoice and microwave leakage report.

Microwave Fault Codes

Fault Codes	
F3	Key panel shorted for 60 seconds
F4	Open humidity (gas) sensor
F5	Shorted humidity (gas) sensor

The following fault codes will be shown in the display and a 4-beep signal will occur when the control panel or sensor malfunctions.

Fault code F3 will occur when the key panel is shorted for more than 60 seconds.

F3 - Key panel shorted for 60 seconds

F4 - Open gas (humidity) sensor

F5 - Shorted gas (humidity) sensor

Fault code F3 will occur when the key panel is shorted for more than 60 seconds. The fault will be displayed until the CLEAR/OFF pad is pushed.

Fault codes F4 and F5 will only occur when using Sensor Cooking (Auto Sensor).

Microwave Diagnostic Charts

Microwave Control and/or Display Does Not Operate Properly

Note: Use this diagnostic procedure if unit has one of the following malfunctions:

- No beep (check control program for beeper MUTE)
- Some or all keys do not operate (check for Child Lock Out)
- Display does not show what was entered (check control for display turned OFF)
- Display erratic
- Display blank (check control for display turned OFF)
- Cannot clear display

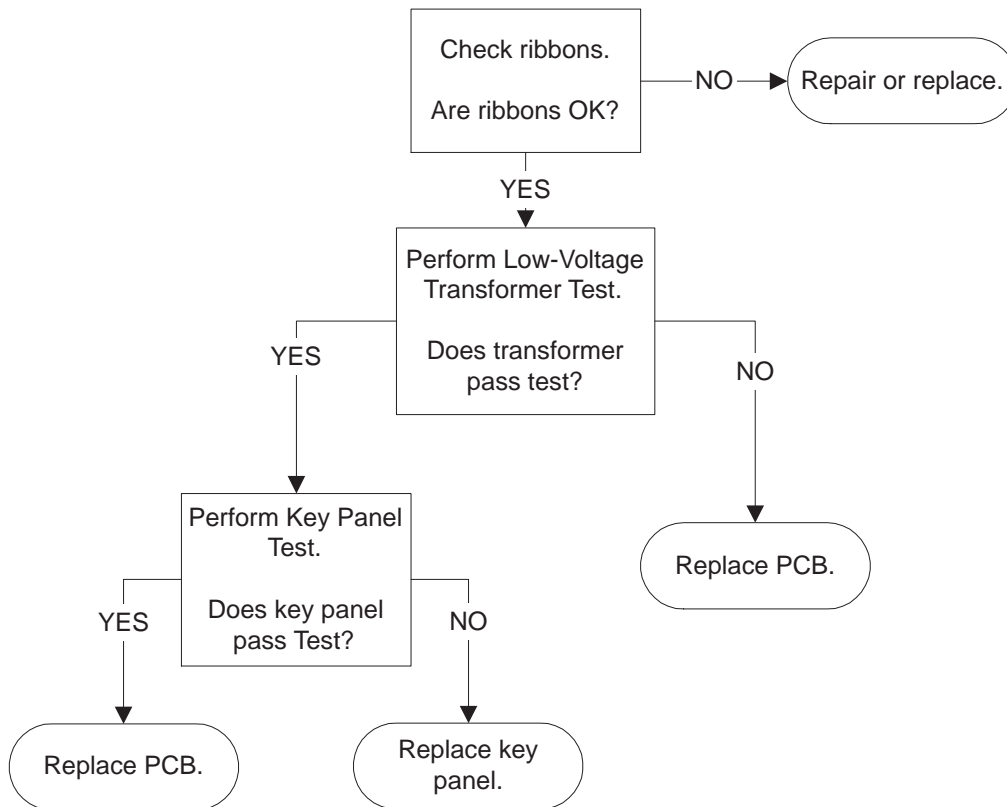

Microwave Unit Dead

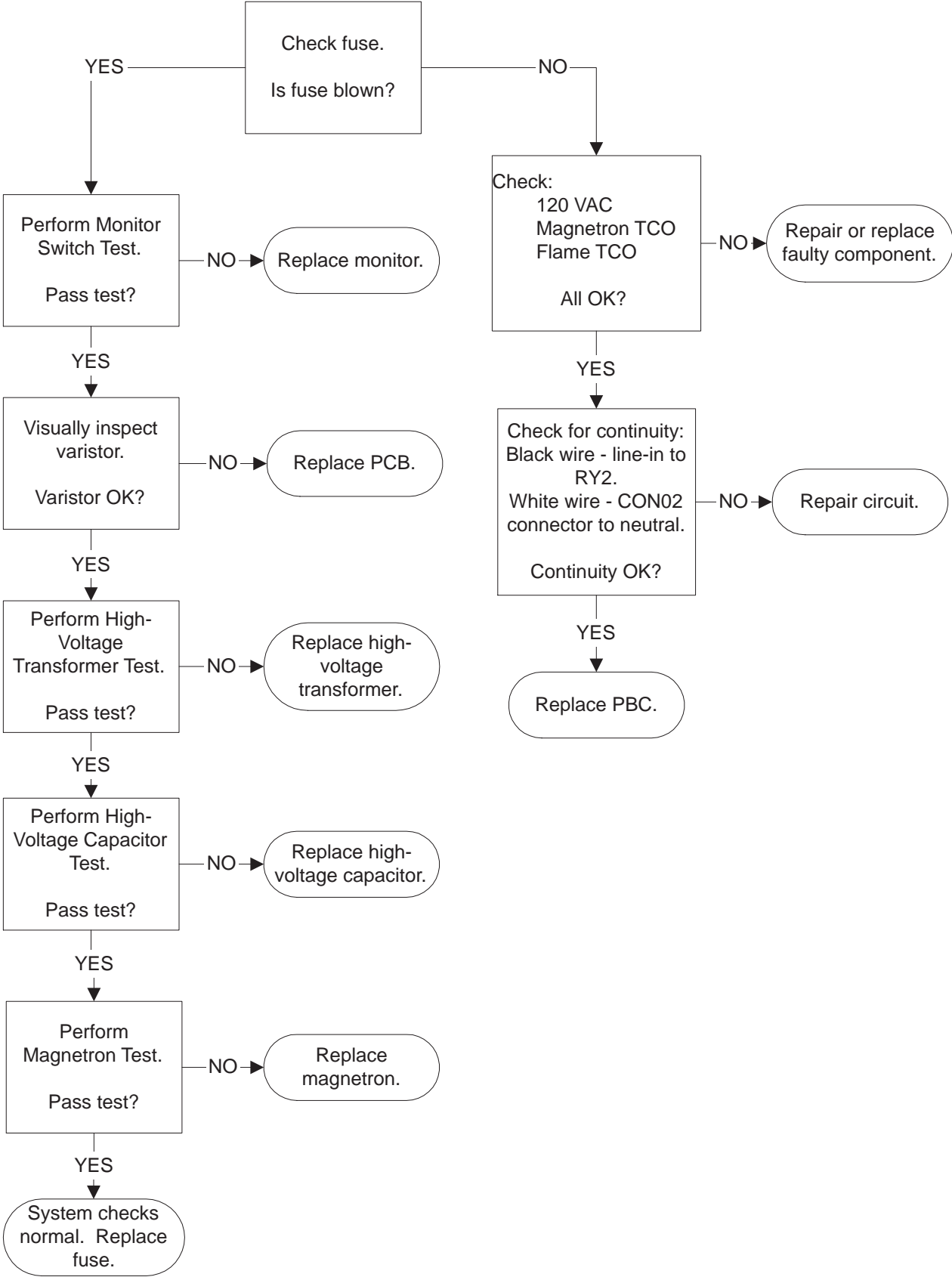

Microwave Oven Runs but Inadequate/No Heating

Note: Verify line voltage under full load.

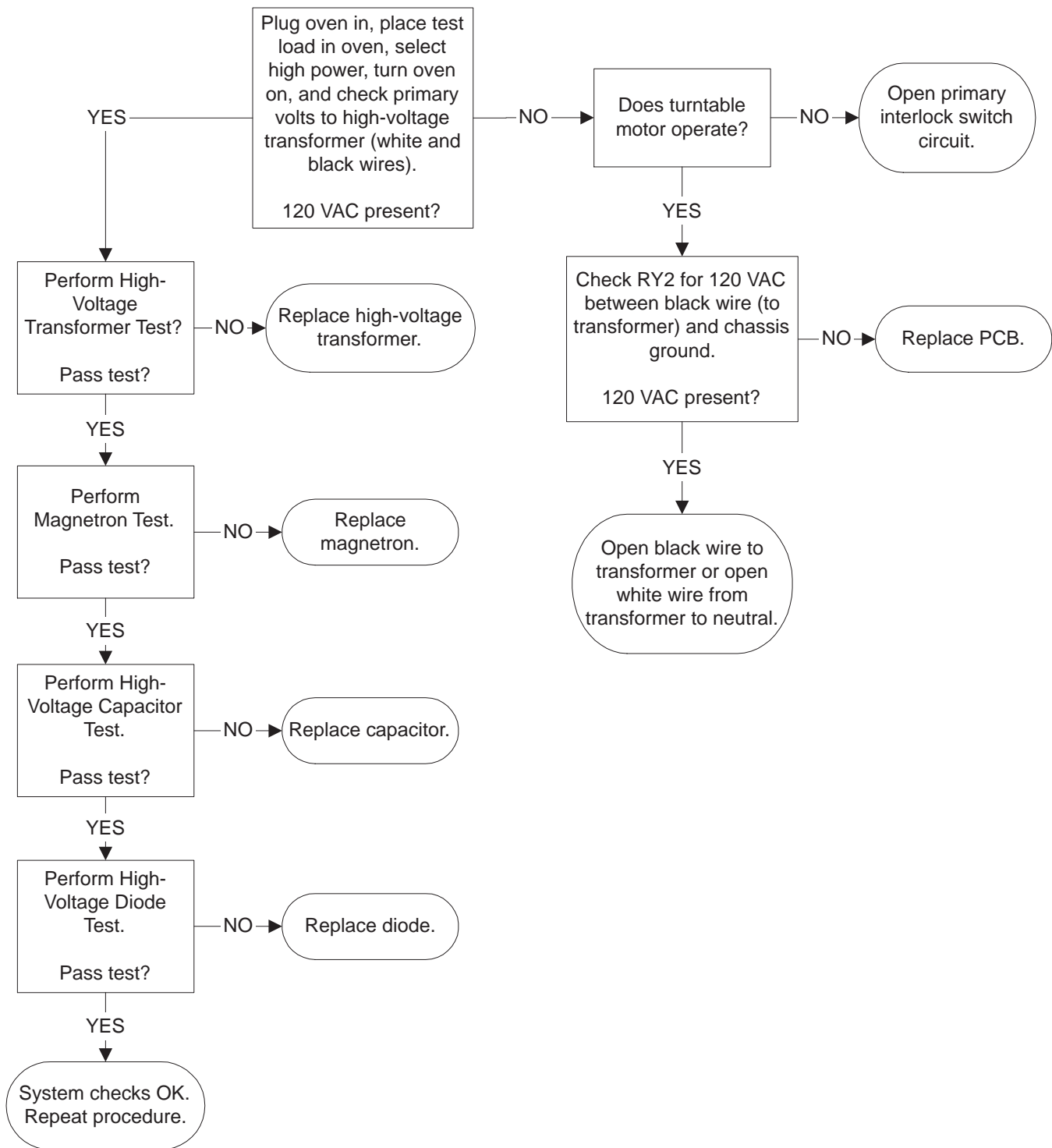

Schematics and Wiring Diagrams

Models ZEK957, JKP56, and JKP45 Schematic

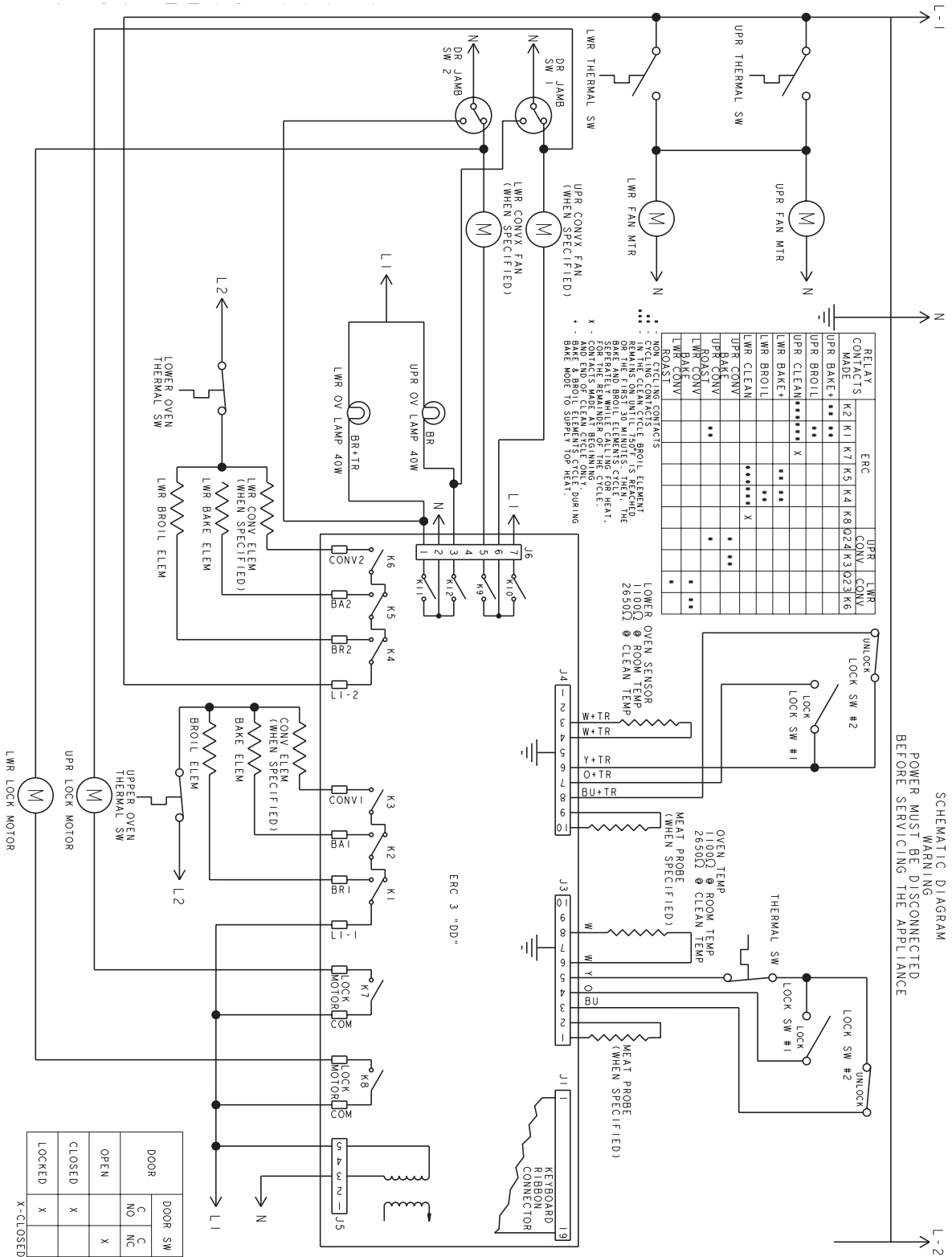

Model JKP27 Schematic

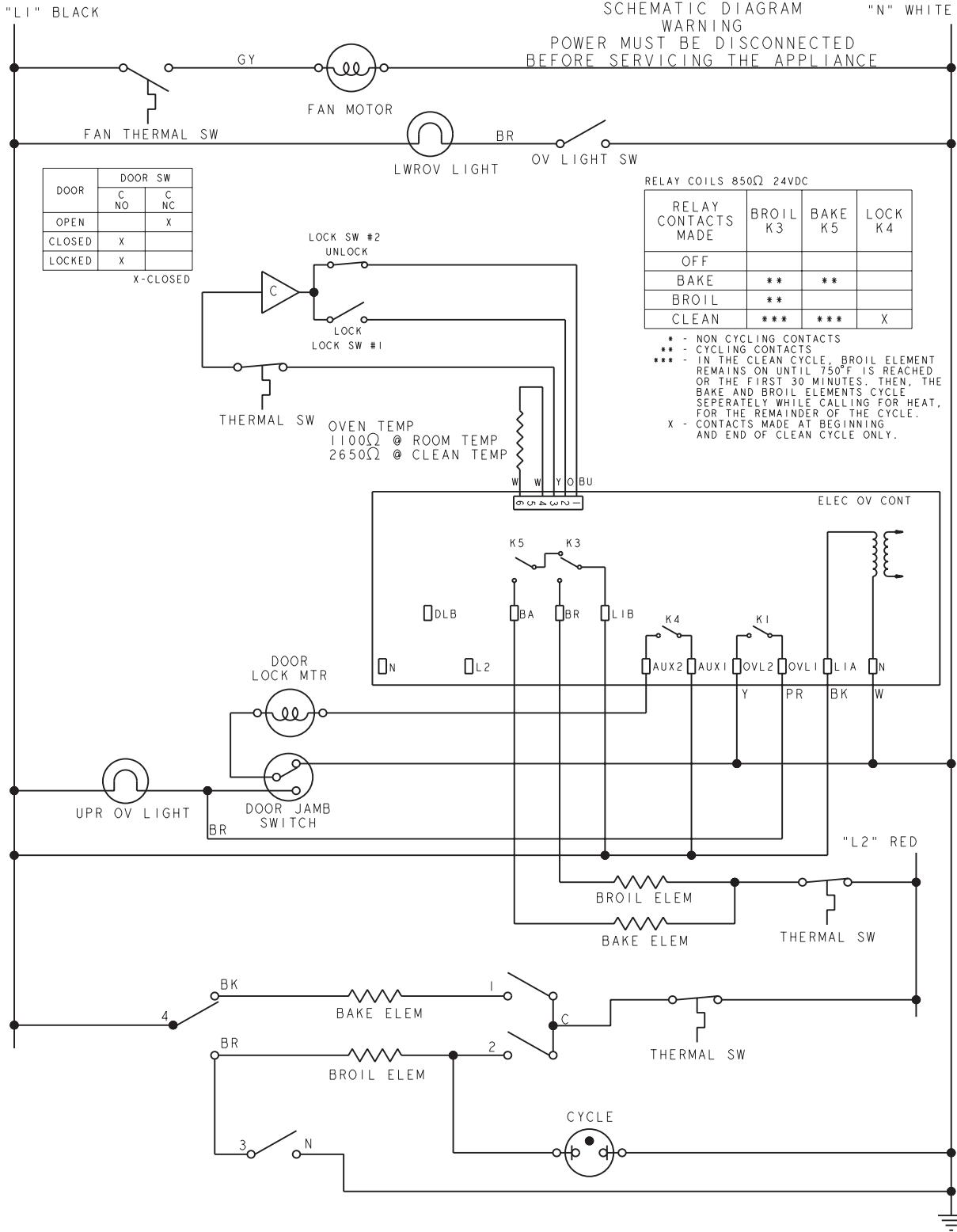

Models ZEK937, JKP18, and JKP15 Schematic

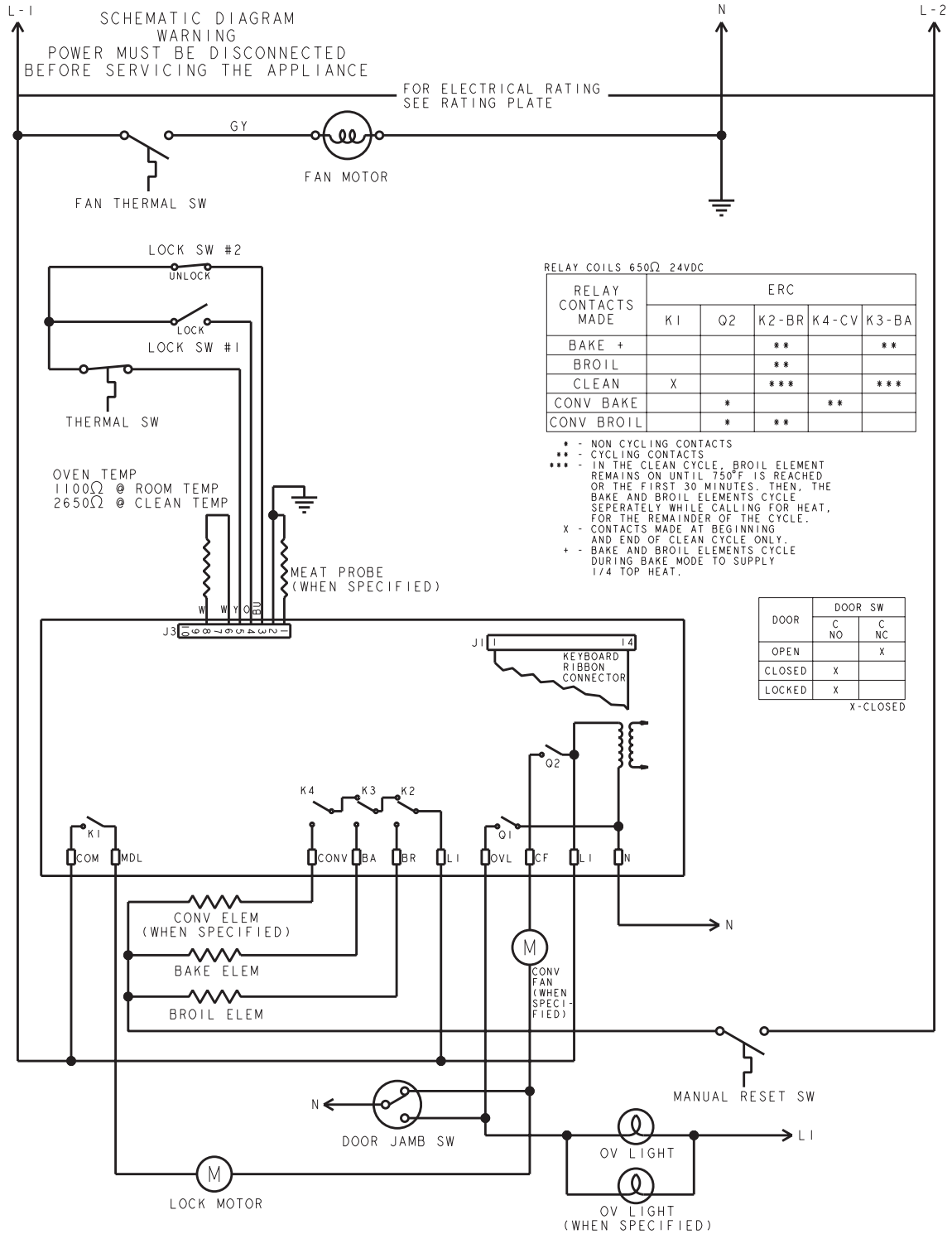

Model JKS05 Schematic

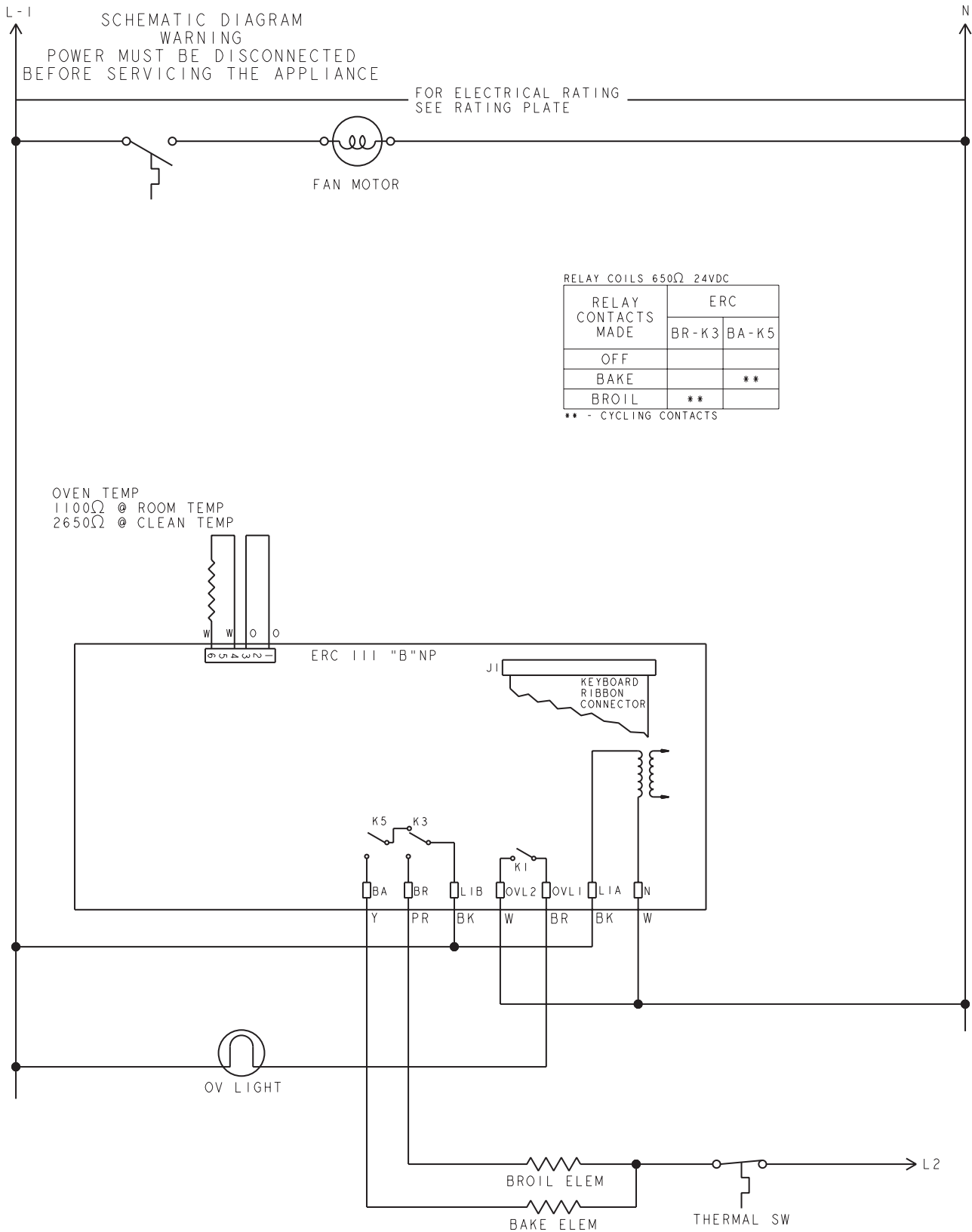

Model JCKS05 Schematic

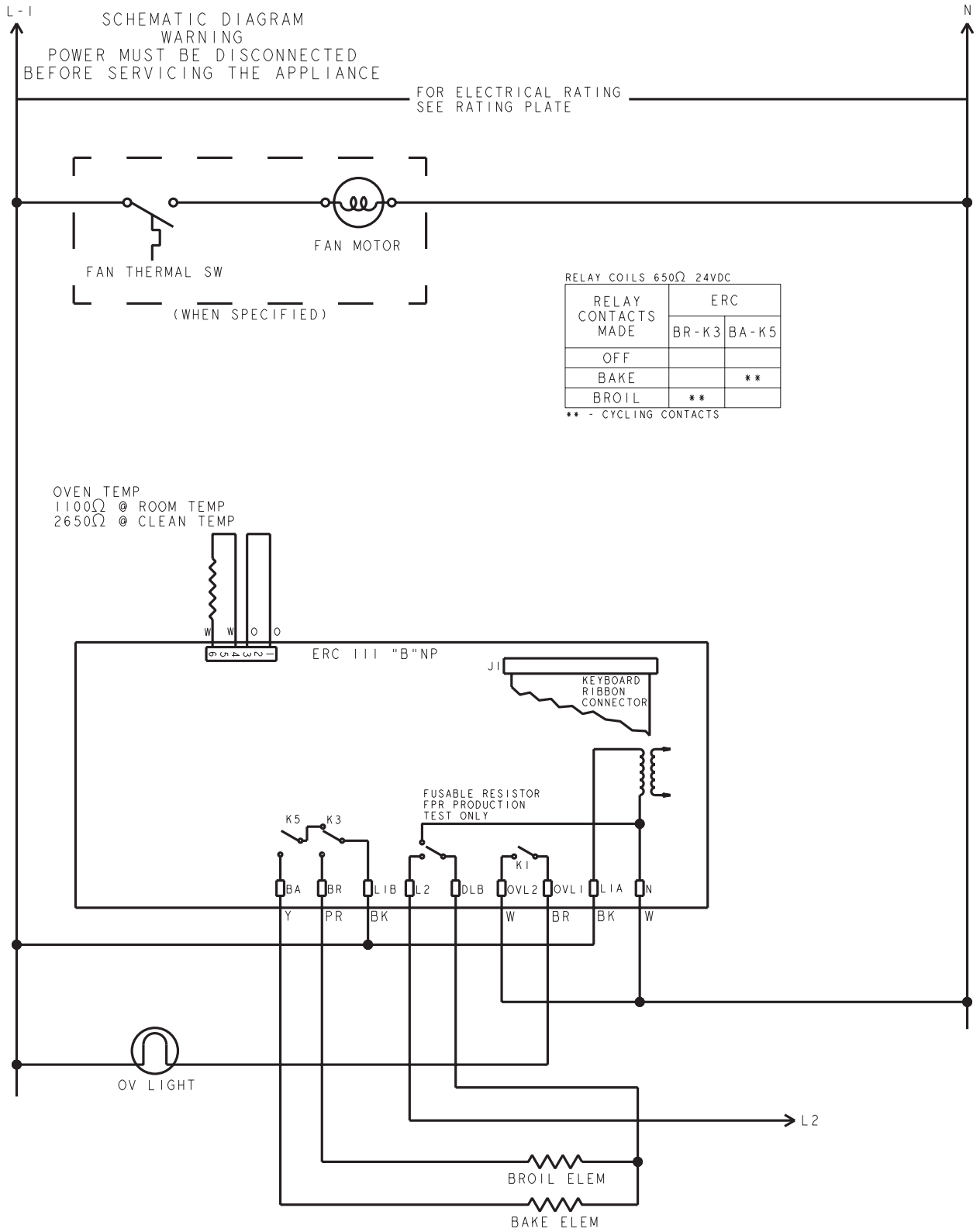

Models JCKP18 and JCKP15 Schematic

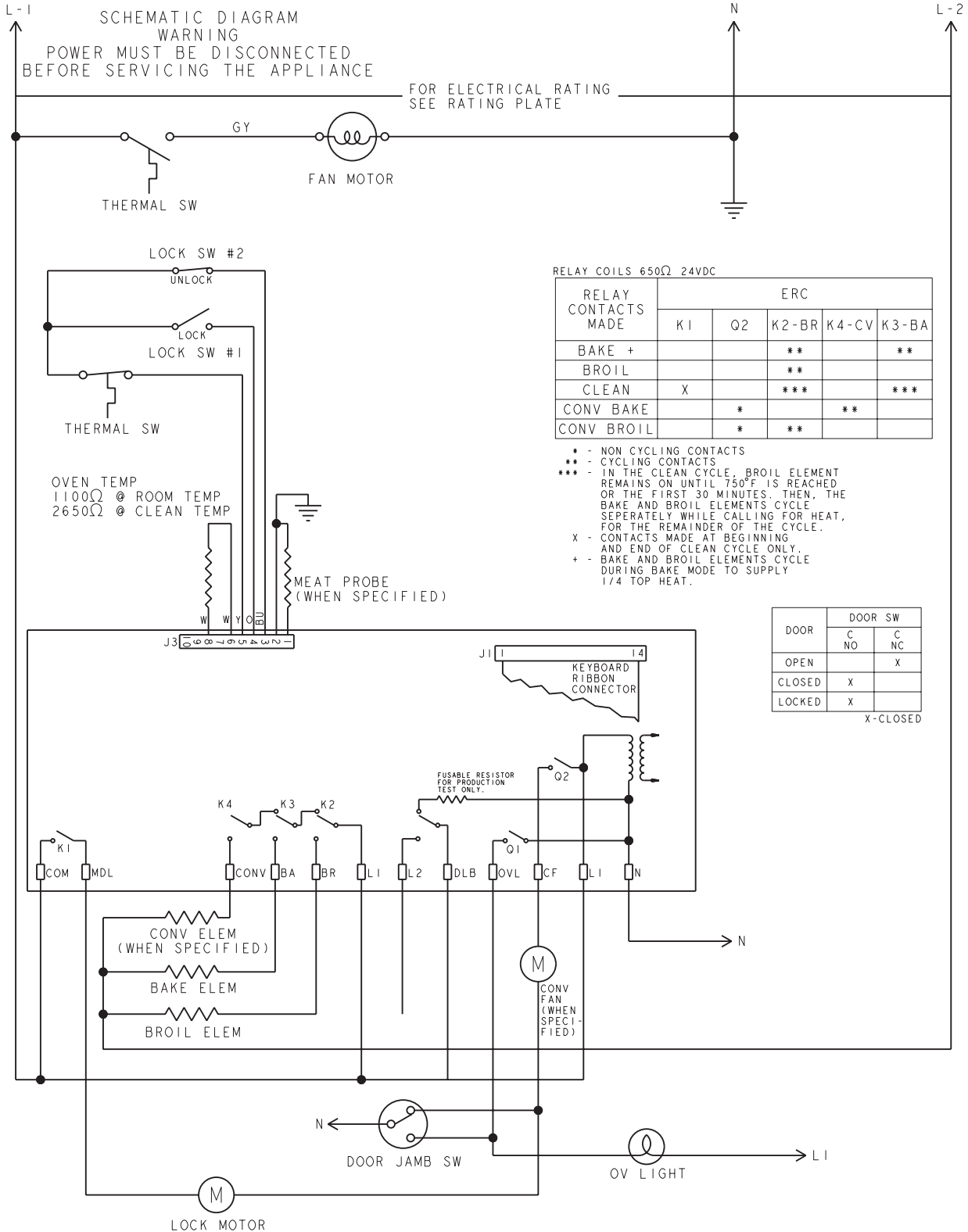

Model JKP85 Schematic

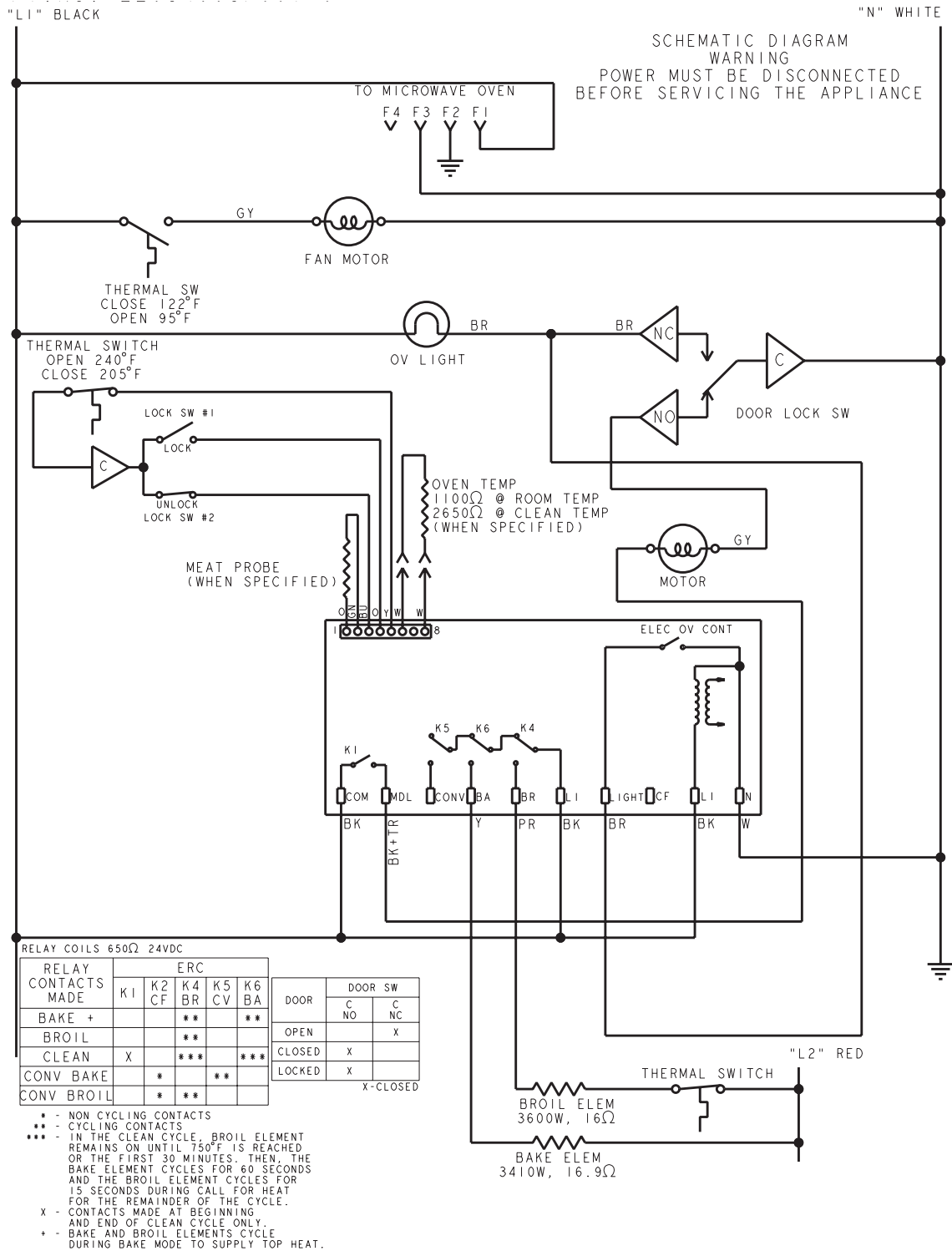

Microwave Schematic

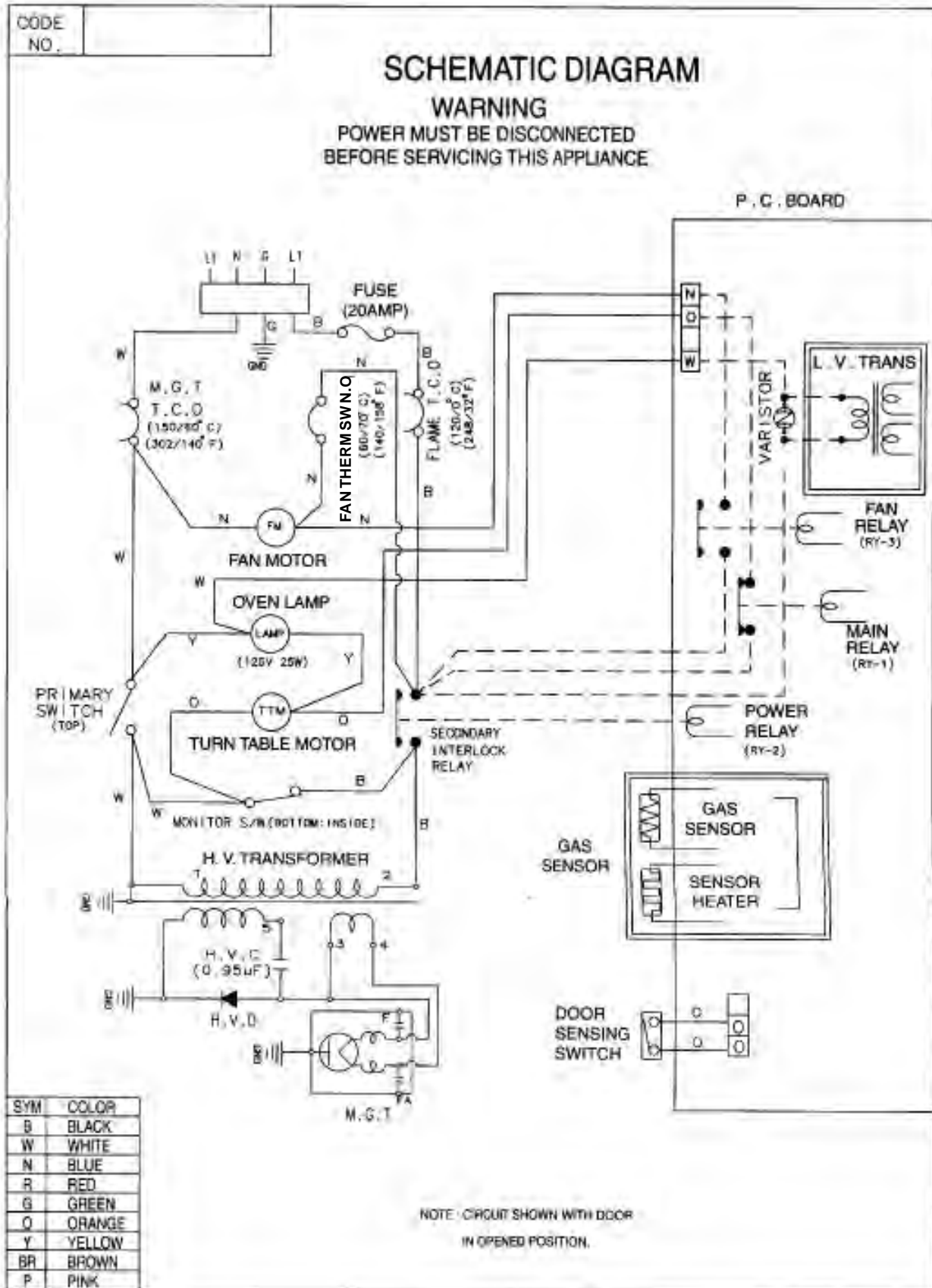

Model ZEK957 Wiring Diagram

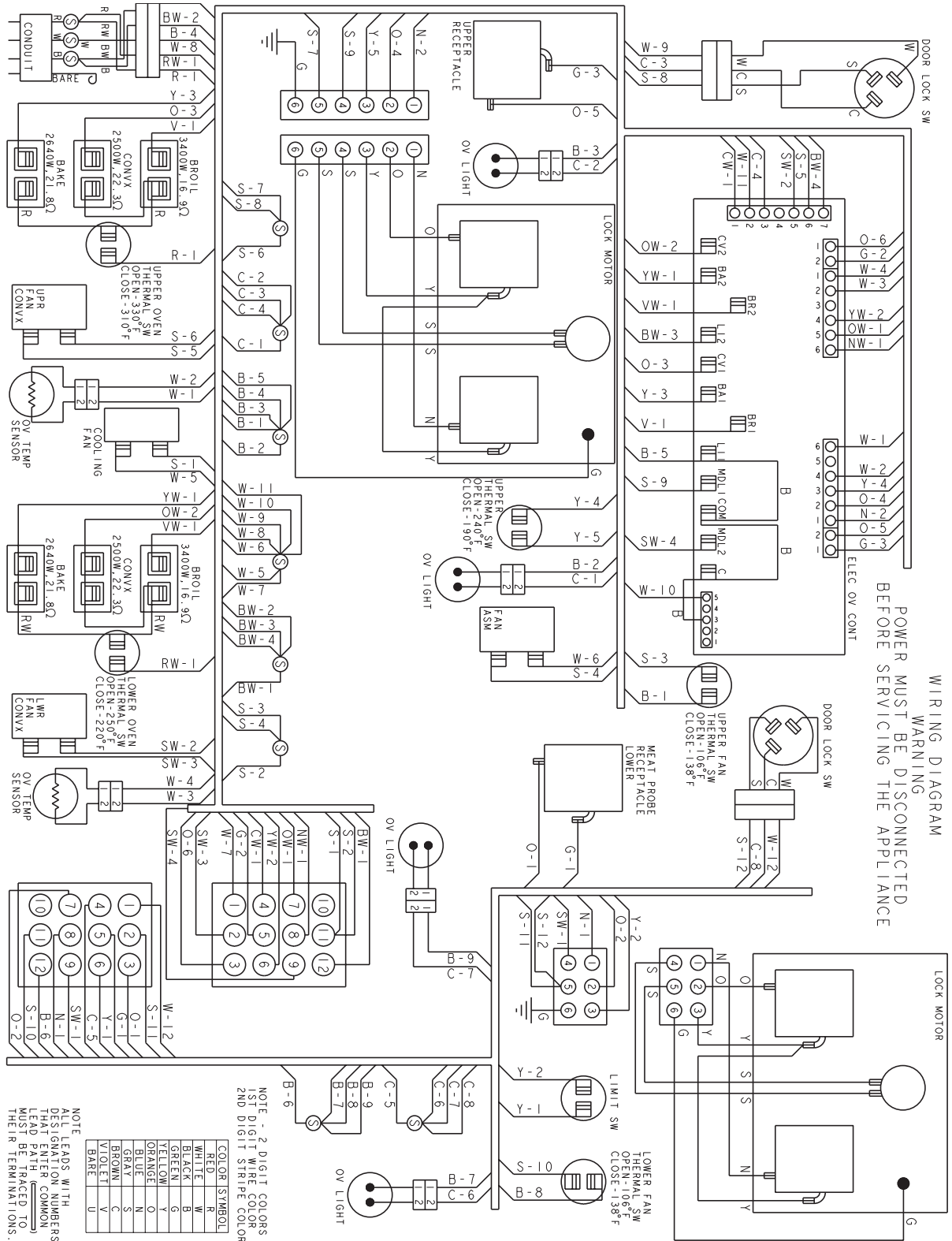

Model ZEK937 Wiring Diagram

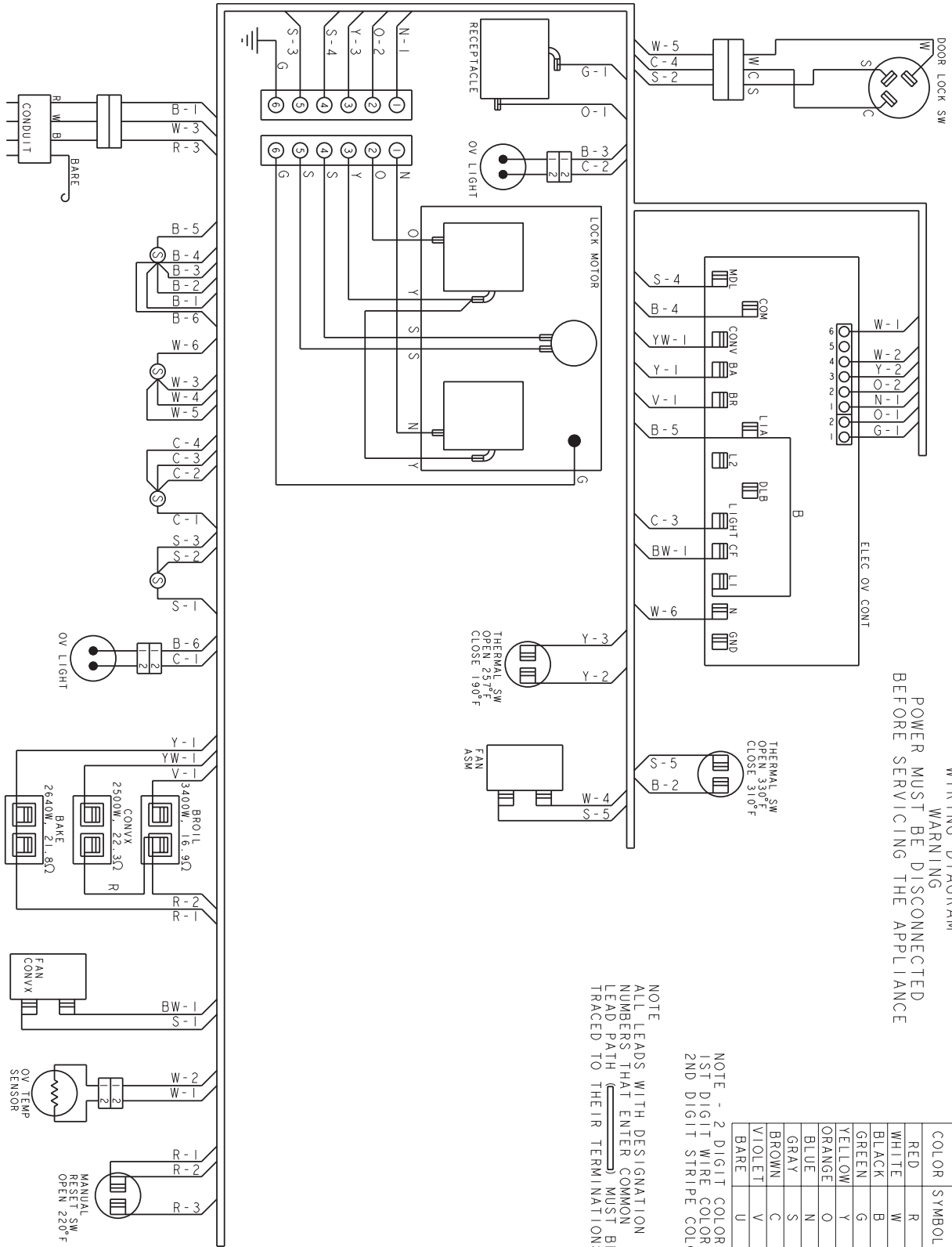

Model JKP27 Wiring Diagram

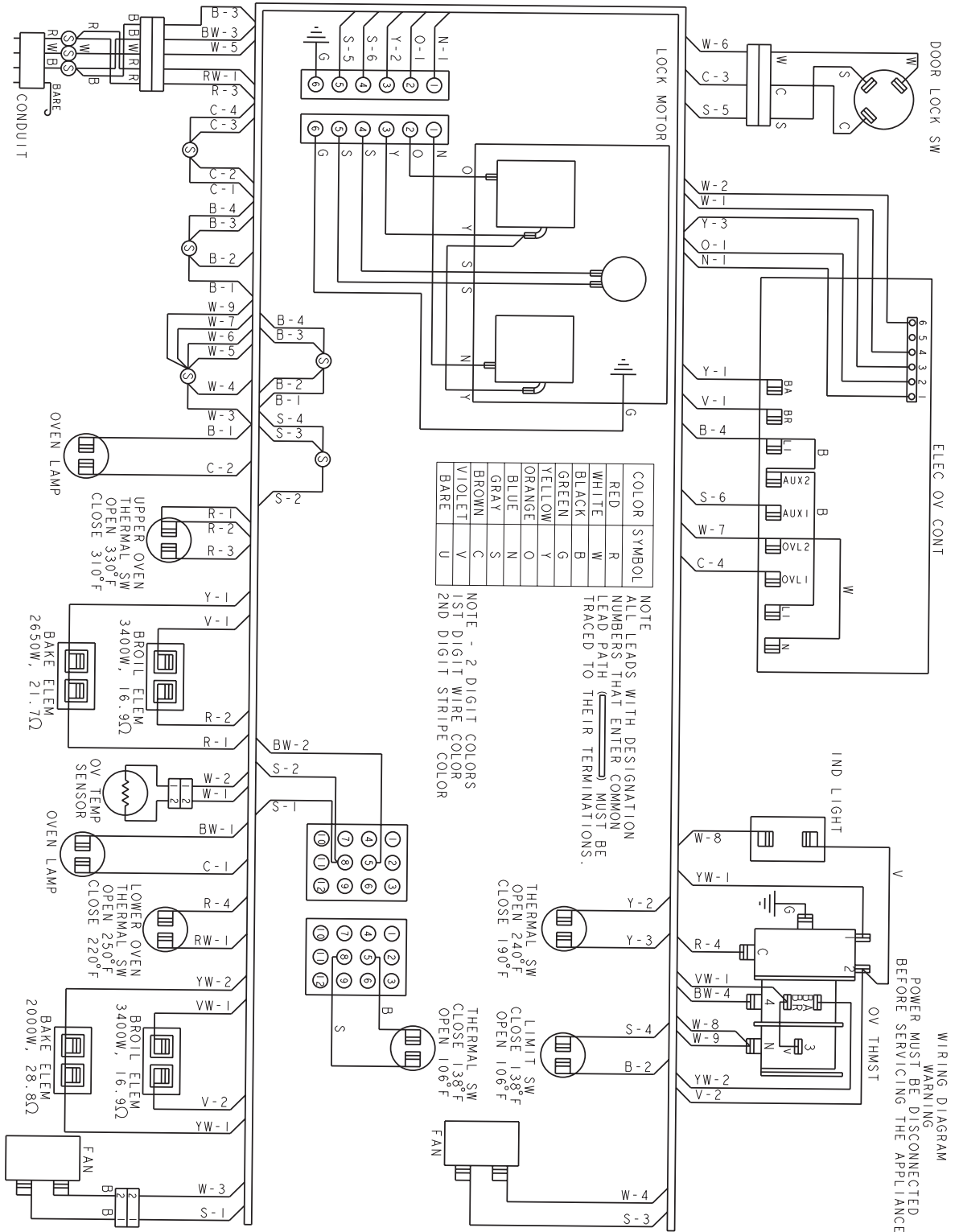

Model JCKP18 Wiring Diagram

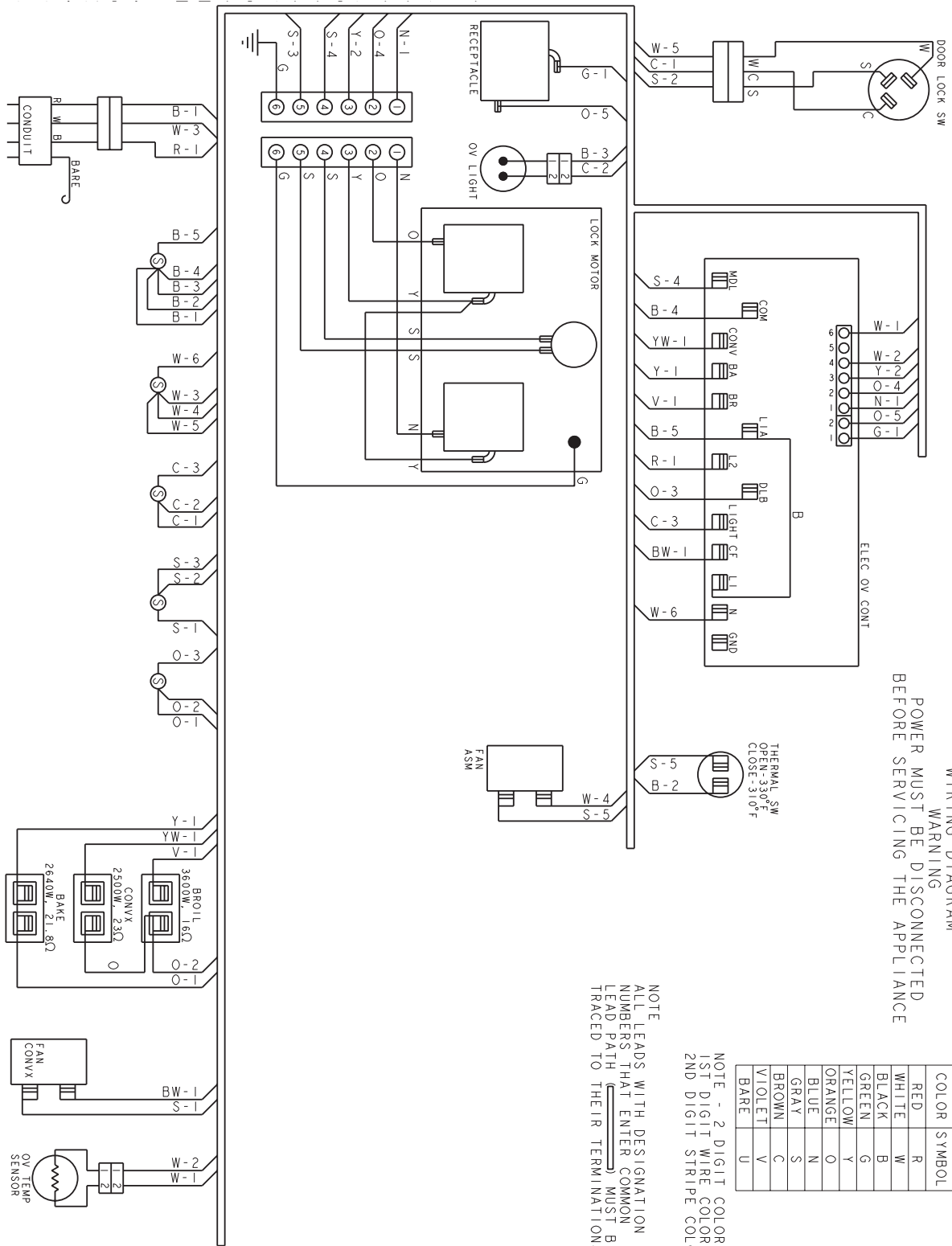

WIRING DIAGRAM
 WARNING
 POWER MUST BE DISCONNECTED
 BEFORE SERVICING THE APPLIANCE

COLOR	SYMBOL
RED	R
WHITE	W
BLACK	B
GREEN	G
YELLOW	Y
ORANGE	O
BLUE	N
GRAY	S
BROWN	C
VIOLET	V
BARE	U

NOTE - 2 DIGIT COLORS
 1ST DIGIT WIRE COLOR
 2ND DIGIT STRIPE COLOR

NOTE
 ALL LEADS WITH DESIGNATION
 NUMBERS THAT ENTER COMMON
 LEAD PATH MUST BE
 TRACED TO THEIR TERMINATIONS.

Model JKP18 Wiring Diagram

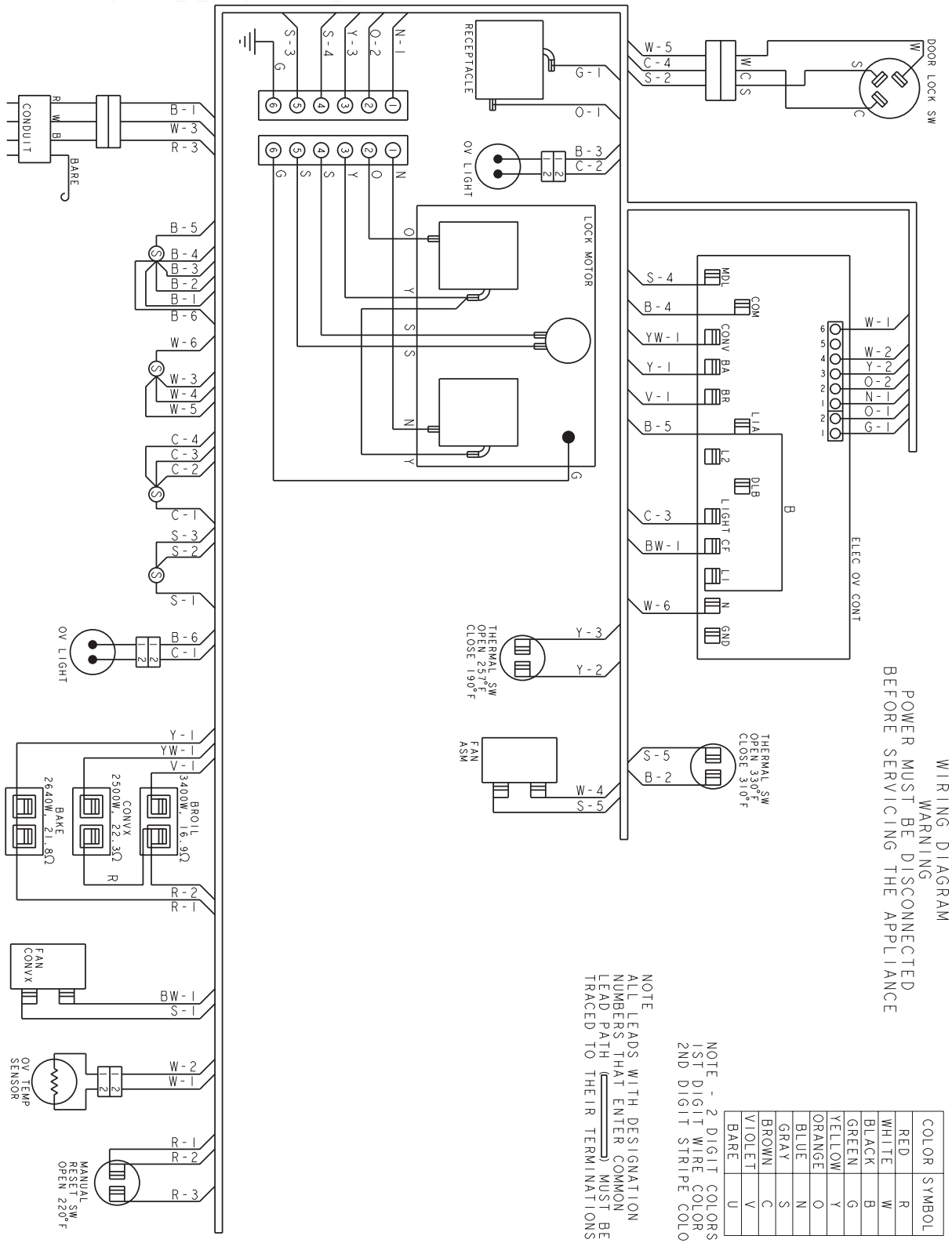

Model JCKP15 Wiring Diagram

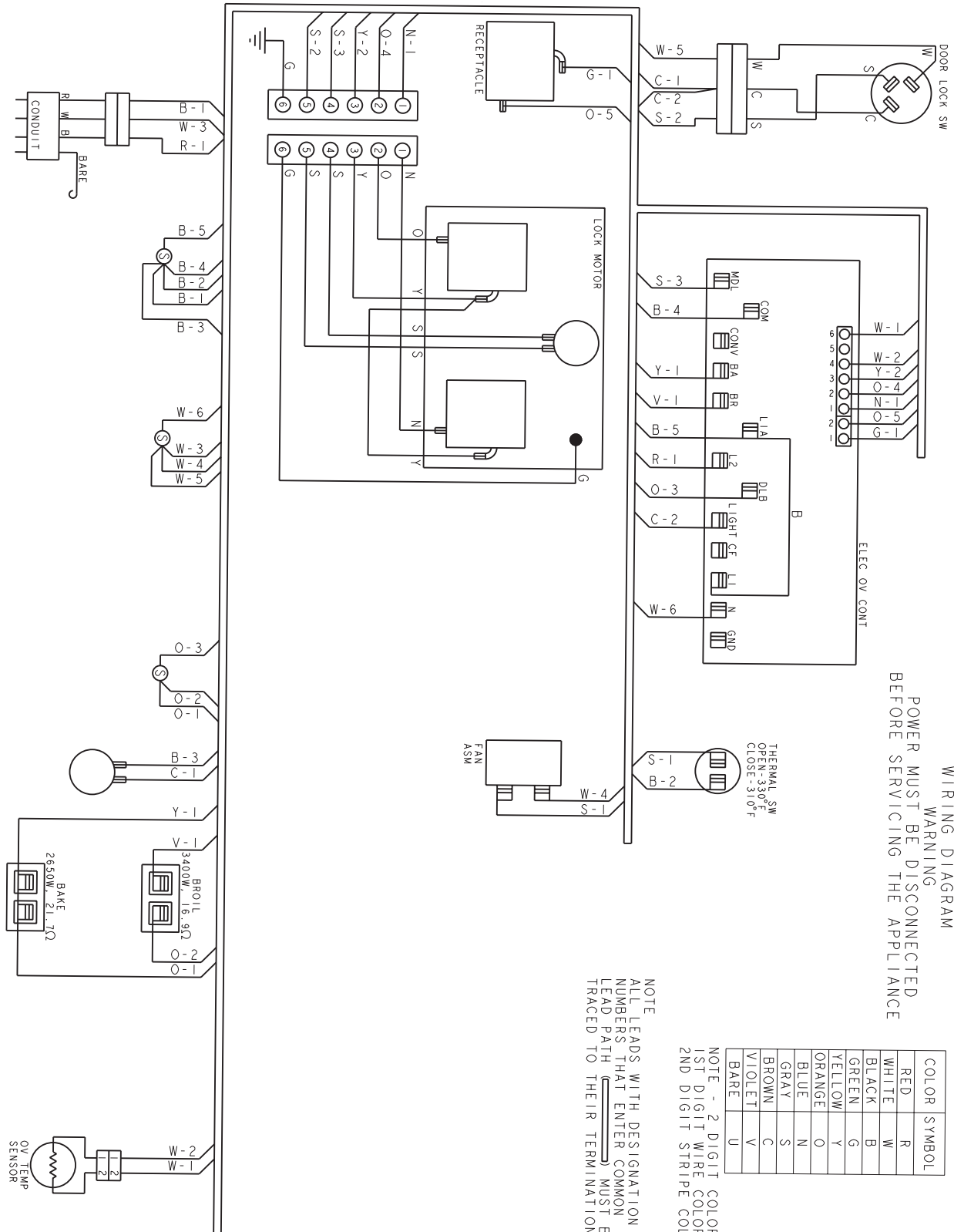

WIRING DIAGRAM
 WARNING
 POWER MUST BE DISCONNECTED
 BEFORE SERVICING THE APPLIANCE

COLOR	SYMBOL
RED	R
WHITE	W
BLACK	B
GREEN	G
YELLOW	Y
ORANGE	O
BLUE	N
GRAY	S
BROWN	C
VIOLET	V
BARE	U

NOTE - 2 DIGIT COLORS
 1ST DIGIT WIRE COLOR
 2ND DIGIT STRIPE COLOR

NOTE
 ALL LEADS WITH DESIGNATION
 NUMBERS THAT ENTER COMMON
 LEAD PATH MUST BE
 TRACED TO THEIR TERMINATIONS.

Model JCKS05 Wiring Diagram

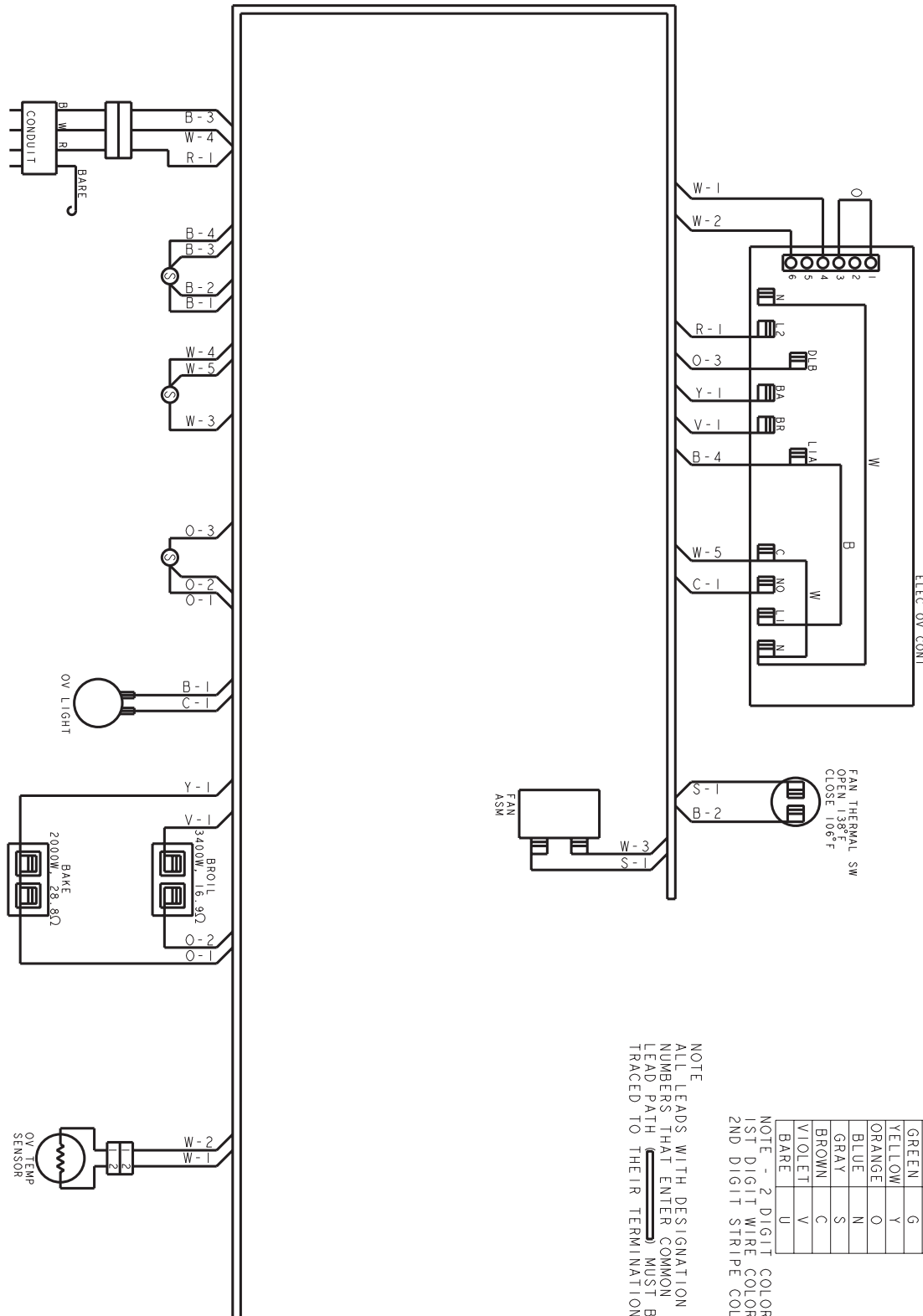

WIRING DIAGRAM
 WARNING
 POWER MUST BE DISCONNECTED
 BEFORE SERVICING THE APPLIANCE

COLOR	SYMBOL
RED	R
WHITE	W
BLACK	B
GREEN	G
YELLOW	Y
ORANGE	O
BLUE	B
GRAY	S
BROWN	C
VIOLET	V
BARE	U

NOTE - 2 DIGIT COLORS
 1ST DIGIT WIRE COLOR
 2ND DIGIT STRIPE COLOR

NOTE
 ALL LEADS WITH DESIGNATION
 NUMBERS THAT ENTER COMMON
 LEAD PATH (ENTERED) MUST BE
 TRACED TO THEIR TERMINATIONS.

Model JKS05 Wiring Diagram

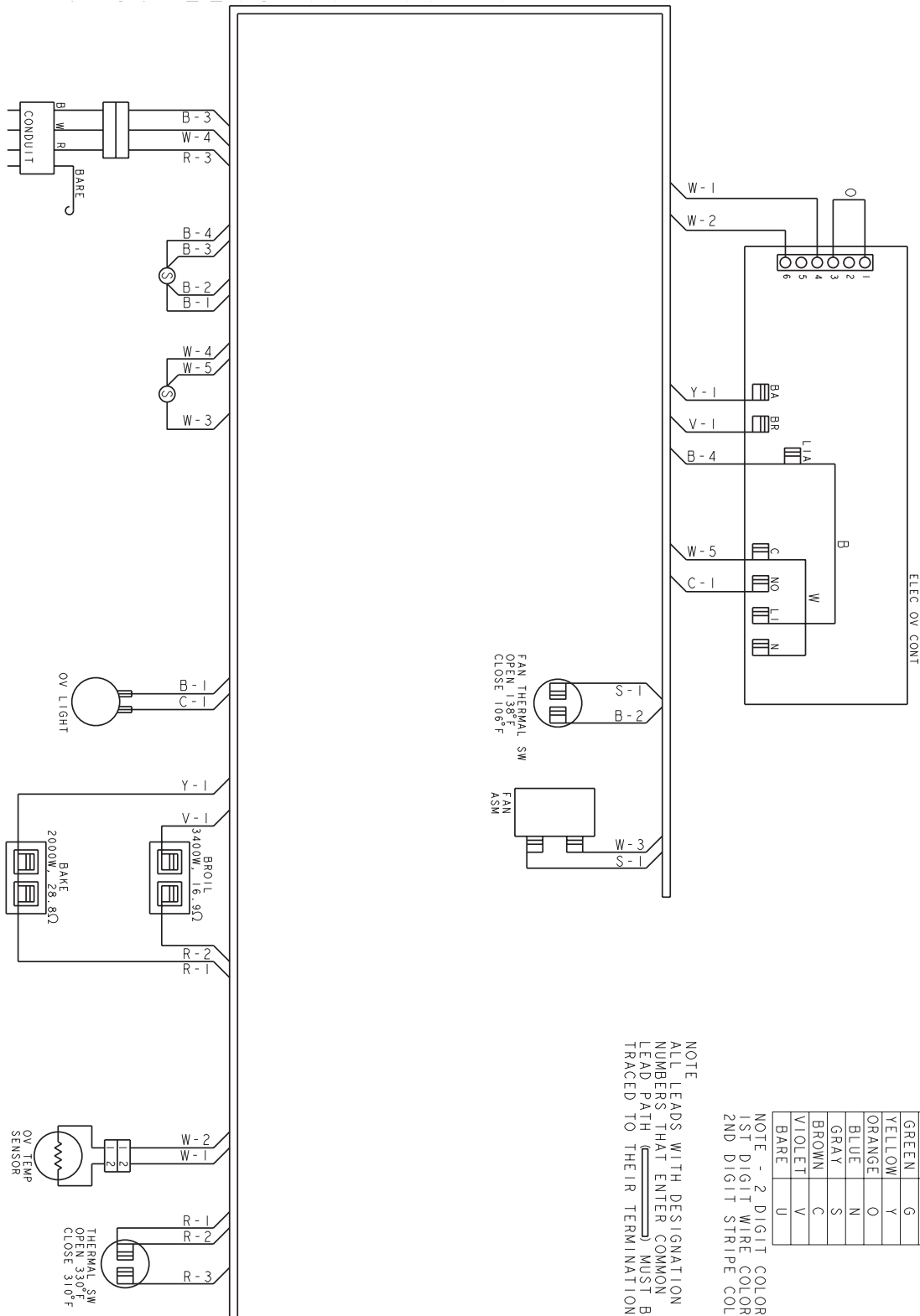

WIRING DIAGRAM
WARNING
POWER MUST BE DISCONNECTED
BEFORE SERVICING THE APPLIANCE

COLOR	SYMBOL
RED	R
WHITE	W
BLACK	B
GREEN	G
YELLOW	Y
ORANGE	O
BLUE	N
GRAY	S
BROWN	C
VIOLET	V
BARE	U

NOTE - 2 DIGIT COLORS
1ST DIGIT WIRE COLOR
2ND DIGIT STRIPE COLOR

NOTE
ALL LEADS WITH DESIGNATION
NUMBERS THAT ENTER COMMON
LEAD PATH MUST BE
TRACED TO THEIR TERMINATIONS.

Model JKP85 Wiring Diagram

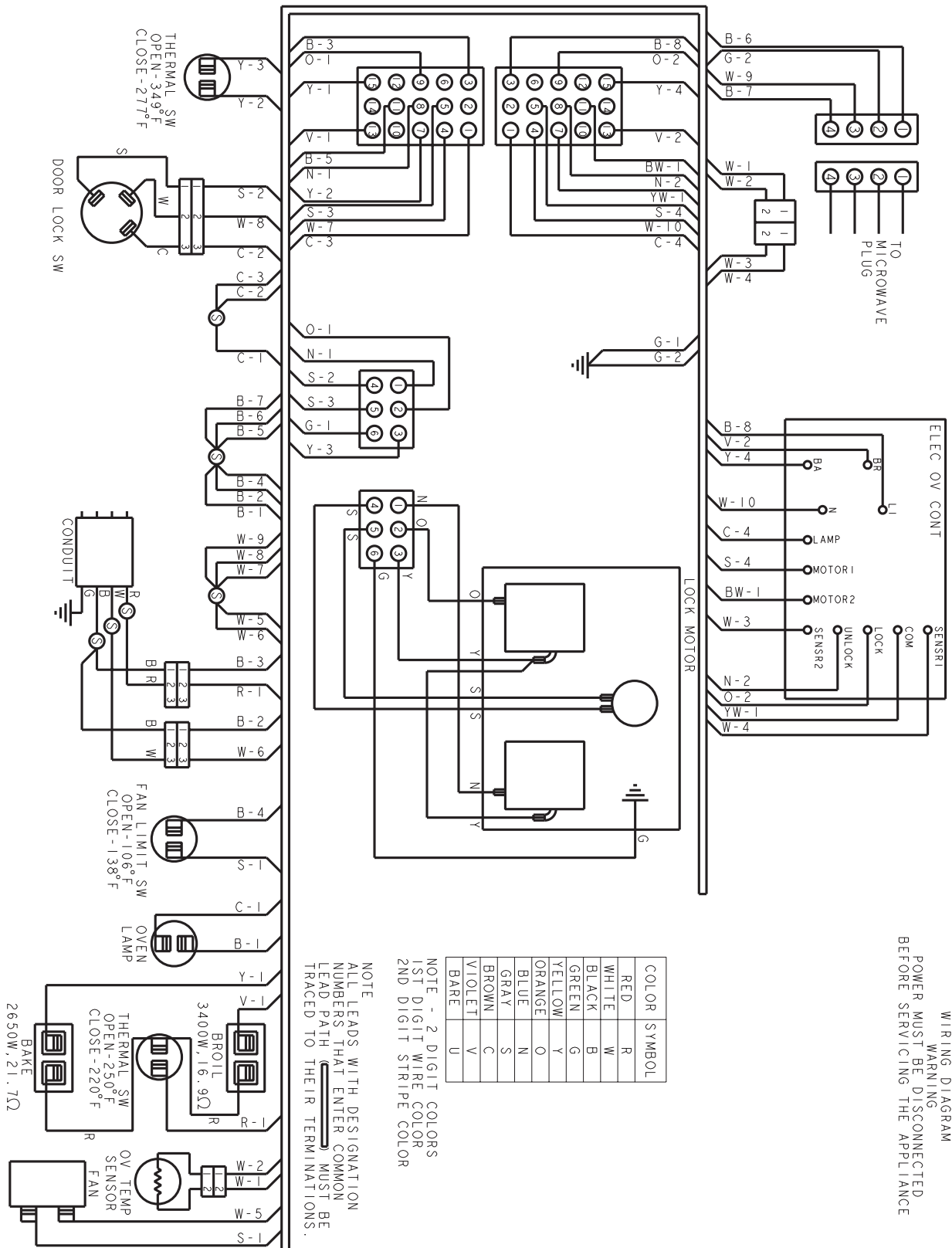

WIRING DIAGRAM
WARNING
 POWER MUST BE DISCONNECTED
 BEFORE SERVICING THE APPLIANCE

COLOR	SYMBOL
RED	R
WHITE	W
BLACK	B
GREEN	G
YELLOW	Y
ORANGE	O
BLUE	N
GRAY	S
BROWN	C
VIOLET	V
BARE	U

NOTE - 2 DIGIT COLORS
 1ST DIGIT WIRE COLOR
 2ND DIGIT STRIPE COLOR

NOTE
 ALL LEADS WITH DESIGNATION
 NUMBERS THAT ENTER COMMON
 LEAD PATH MUST BE
 TRACED TO THEIR TERMINATIONS.

Microwave Wiring Diagram

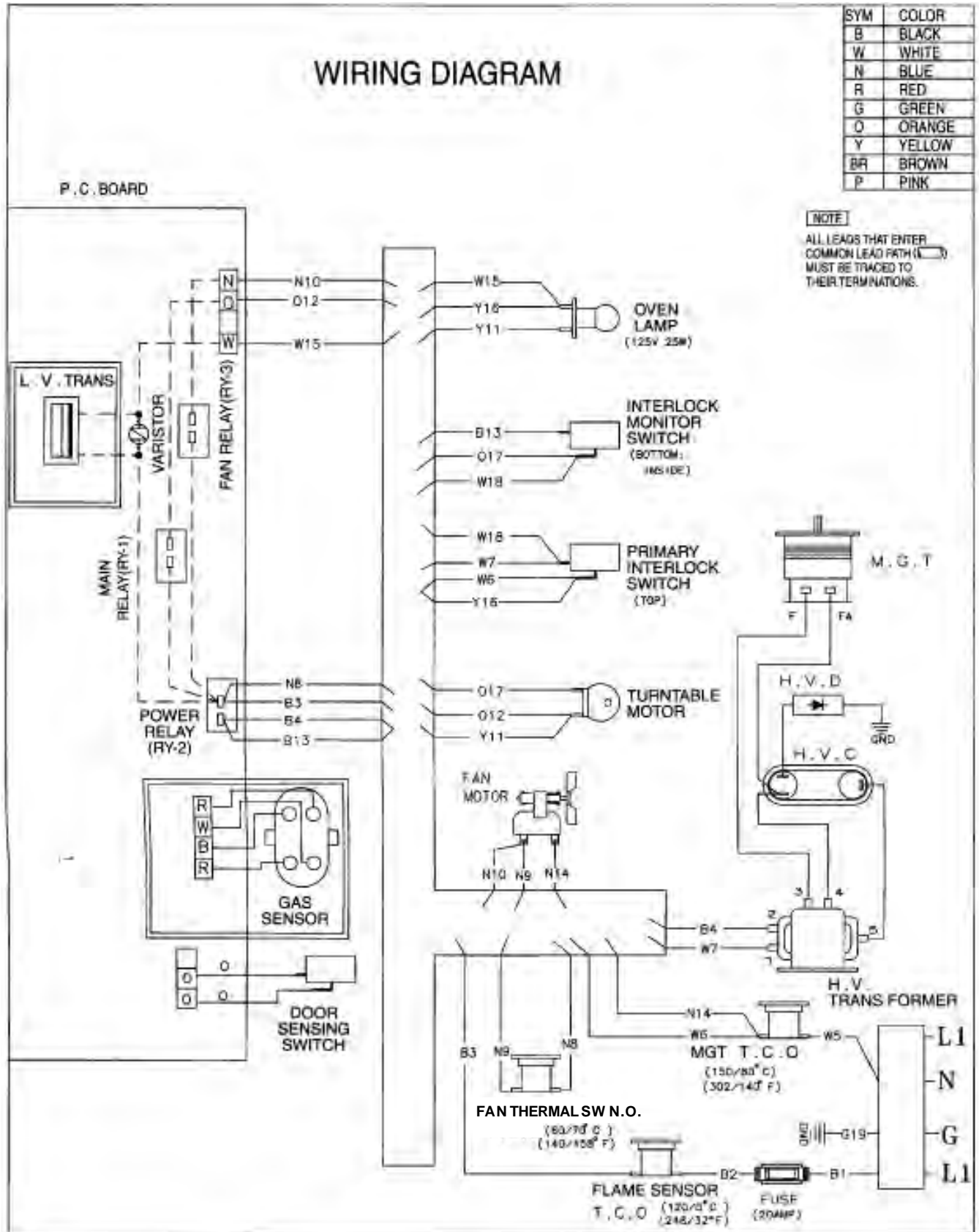

Quiz

1. If the voltage output or resistance of the low-voltage transformer is not correct in either the oven or the microwave, you should replace the PCB.
 True False
2. To replace the oven door gasket, you must first remove the oven door from the oven.
 True False
3. After installing a new hinge replacement on the oven door, you must be sure the new hinge is in the cocked and locked position before the oven door can be installed on the oven.
 True False
4. When performing a key panel test, the ohmmeter should show infinity ohms when depressing the pad, and show some resistance without depressing the pad.
 True False
5. Replacement of the oven thermal cutout switch and the convection fan motor are the only components that require removal of the oven from installation.
 True False
6. What test is made to check for a damaged varistor?
 Resistance Voltage Visual
7. The F-codes for the oven and the F-codes for the microwave are all very similar, but not the same.
 True False
8. When the oven door is either being locked or unlocked, both lock switches will be in the open position and the display will flash the words LOCK DOOR.
 True False
9. Replacement control panel parts come with an oven PCB and a microwave PCB.
 True False
10. Convection fan blade nut has left-handed threads.
 True False

Warranties

Built-In Electric Oven Warranty



All warranty service provided by our Factory Service Centers, or an authorized Customer Care® technician. To schedule service, on-line, 24 hours a day, visit us at www.GEAppliances.com, or call 800.GE.CARES (800.432.2737).

Staple your receipt here.
Proof of the original purchase date is needed to obtain service under the warranty.

For The Period Of: **GE Will Replace:**

One Year
From the date of the original purchase

Any part of the oven which fails due to a defect in materials or workmanship. During this **full one-year warranty**, GE will also provide, **free of charge**, all labor and in-home service to replace the defective part.

What GE Will Not Cover:

- Service trips to your home to teach you how to use the product.
- Improper installation.
- Failure of the product if it is abused, misused, or used for other than the intended purpose or used commercially.
- Replacement of house fuses or resetting of circuit breakers.
- Damage to the product caused by accident, fire, floods or acts of God.
- Incidental or consequential damage caused by possible defects with this appliance.

This warranty is extended to the original purchaser and any succeeding owner for products purchased for home use within the USA. In Alaska, the warranty excludes the cost of shipping or service calls to your home.

Some states do not allow the exclusion or limitation of incidental or consequential damages. This warranty gives you specific legal rights, and you may also have other rights which vary from state to state. To know what your legal rights are, consult your local or state consumer affairs office or your state's Attorney General.

Warrantor: General Electric Company, Louisville, KY 40225

Built-In Microwave Cooking Center Warranty



All warranty service provided by our Factory Service Centers, or an authorized Customer Care® technician. To schedule service, on-line, 24 hours a day, visit us at www.GEAppliances.com, or call 800.GE.CARES (800.432.2737).

Staple your receipt here.
Proof of the original purchase date is needed to obtain service under the warranty.

For The Period Of:	GE Will Replace:
<p>One Year From the date of the original purchase</p>	<p>Any part of the microwave cooking center which fails due to a defect in materials or workmanship. During this full one-year warranty, GE will also provide, free of charge, all labor and in-home service to replace the defective part.</p>
<p>Limited Additional Four-Year For the second through the fifth year from date of the original purchase</p>	<p>A replacement magnetron tube the magnetron tube fails because of a manufacturing defect. During this limited additional four-year warranty, you will be responsible for any labor or in-home service.</p>

What GE Will Not Cover:

- Service trips to your home to teach you how to use the product.
- Improper installation.
- Failure of the product if it is abused, misused, or used for other than the intended purpose or used commercially.
- Replacement of house fuses or resetting of circuit breakers.
- Damage to the product caused by accident, fire, floods or acts of God.
- Incidental or consequential damage caused by possible defects with this appliance.

This warranty is extended to the original purchaser and any succeeding owner for products purchased for home use within the USA. In Alaska, the warranty excludes the cost of shipping or service calls to your home.

Some states do not allow the exclusion or limitation of incidental or consequential damages. This warranty gives you specific legal rights, and you may also have other rights which vary from state to state. To know what your legal rights are, consult your local or state consumer affairs office or your state's Attorney General.

Warrantor: General Electric Company, Louisville, KY 40225