

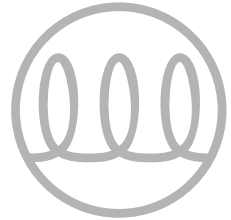

ICON™
Designer Series
36" Induction Drop-In Cooktop
SERVICE MANUAL

MODEL E36IC75FSS



NOTICE

This service manual is intended for use by persons having electrical and mechanical training and a level of knowledge of these subjects generally considered acceptable in the appliance repair trade. The manufacturer cannot be responsible, nor assume any liability for injury or damage of any kind arising from the use of this data sheet.

TABLE OF CONTENTS

SAFE SERVICING PRACTICES	3	BASIC OPERATION	18 - 20
SERVICE TIPS - DEVELOP GOOD WORK HABITS	4	USING THE TOUCH CONTROL	18
SERVICE TOOLS AND EQUIPMENT	4	OPERATING THE COOKING ZONES	18
INDUCTION COOKTOP FEATURES ..5 - 6		PREHEAT RECOMMENDATIONS	20
INDUCTION COOKTOP WIRING DIAGRAM	7	KEEP WARM FEATURE	20
INSTALLATION INSTRUCTIONS	8 - 12	MINUTE TIMER	20
INTRODUCTION TO INDUCTION COOKING	13	COMPONENT ACCESS AND SERVICE PROCEDURES	21-28
HOW INDUCTION COOKING WORKS	13	REMOVING COOKTOP GLASS	21
SELECTING PROPER COOKWARE	14 - 15	REMOVING TOUCH CONTROL BOARDS	22
DETERMINING PAN SIZE	14	TOUCH CONTROL BOARD WIRING	22
INSPECTING PAN BOTTOM	15	REMOVING INDUCTION COILS	23
INDUCTION COOKTOP DISPLAY MESSAGES	16 - 17	REMOVING THE COIL CARRIER	24
LED MESSAGES OR LIGHT INDICATORS DISPLAYED BY MAIN CONTROL	16	MAIN POWER COMPONENTS	24
LED MESSAGES OR LIGHT INDICATORS DISPLAYED BY COOKING ZONE CONTROLS	16 - 17	REPLACING THE INDUCTION GENERATOR POWER BOARD	25
		FILTER BOARD REPLACEMENT (TWO COOK ZONE MODULE)	26
		FILTER BOARD REPLACEMENT (THREE COOK ZONE MODULE)	27
		TROUBLESHOOTING AND DIAGNOSIS	28 - 32
		ERROR CODES	29
		ELECTROLUX ICON 36" INDUCTION COOKTOP ERROR CODES TABLE	29 - 31
		ADDITIONAL FAILURE CONDITIONS	32
		COMPONENT PARTS ILLUSTRATION	34-37
		CONTROL PANEL AND CIRCUIT BOARDS	34 - 35
		MAIN TOP AND SURFACE UNITS	36 - 37

SAFE SERVICING PRACTICES

- ALL APPLIANCES -

To avoid personal injury and/or property damage, it is important that Safe Servicing Practices be observed. The following are some limited examples of safe practices:

1. **DO NOT** attempt a product repair if you have any doubts as to your ability to complete it in a safe and satisfactory manner.
2. **Before servicing or moving an appliance:**
 - Remove the power cord from the electrical outlet, trip the circuit breaker to the **OFF** position, or remove the fuse.
 - Turn off the gas supply.
 - Turn off the water supply.
3. **Never interfere with the proper operation of any safety device.**
4. **USE ONLY REPLACEMENT PARTS CATALOGED FOR THIS APPLIANCE. SUBSTITUTIONS MAY DEFEAT COMPLIANCE WITH SAFETY STANDARDS SET FOR HOME APPLIANCES.**
5. **GROUNDING:** The standard color coding for safety ground wires is **GREEN**, or **GREEN with YELLOW STRIPES**. Ground leads are not to be used as current carrying conductors. It is **EXTREMELY** important that the service technician reestablish all safety grounds prior to completion of service. Failure to do so will create a hazard.
6. **Prior to returning the product to service, ensure that:**
 - All electrical connections are correct and secure
 - All electrical leads are properly dressed and secured away from sharp edges, high-temperature components, and moving parts
 - All non-insulated electrical terminals, connectors, heaters, etc. are adequately spaced away from all metal parts and panels
 - All safety grounds (both internal and external) are correctly and securely connected
 - All panels are properly and securely reassembled
 - All gas connections are secure and have been leak tested

ATTENTION!!!

This service manual is intended for use by persons having electrical and mechanical training and a level of knowledge of these subjects generally considered acceptable in the appliance repair trade. The manufacturer cannot be responsible, nor assume any liability, for injury or damage of any kind arising from the use of this manual.

SERVICE TIPS - DEVELOP GOOD WORK HABITS

Consistently following a standard routine when servicing appliances will insure that you do not waste time searching for a complex solution to a simple problem. **One of the most common mistakes made by service technicians is failing to verify the incoming power supply to the appliance.**

Many times electronic controls and other components are replaced unnecessarily because the incoming power supply was not verified. When testing the electrical supply the test should be performed at the terminal block where the power cord or house wiring attaches to the appliance. Verify that there are 240 volts between L1 & L2 and that there is 120 volts from L1 to Neutral and also from L2 to Neutral. You should also check the power supply while the appliance is operating or “under load”. The power supply may check good with the product sitting idle but fail when certain components are turned on. This can be caused by a weak connection in the customer’s house wiring, or a faulty circuit breaker or fuse.

Another common mistake is failure to verify all component part wire harness connections. It is essential that all component connections be checked visually and with the appropriate circuit tester. Many times components are assumed to be faulty because they do not operate or there is an error code displayed by the electronic control system. Often the failure is caused by a loose or miswired connection which can cause the same error code as a defective component part. Newly installed appliances may have loose connections resulting from shipping and handling conditions or improper installation. Check the wiring connections before you order replacement parts.

When the repair has been completed the product should be thoroughly tested to verify that the service performed corrected the problem and that all of the other features and functions of the product are in proper working order. The extra time taken to do this will create consumer confidence in your efficiency and professionalism as well as possibly saving an expensive callback.

SERVICE TOOLS AND EQUIPMENT

In addition to standard hand tools such as wrenches, screwdrivers, pliers, etc; the following instruments are considered to be essential equipment for technicians servicing Electrolux cooking products. Proper testing and diagnostic procedures are not possible without these tools.

- Volt/ohmmeter - Must be capable of voltage measurement from 0 to 500 volts AC and resistance measurements from 0 to 2 meg-ohms. This usually requires a meter that utilizes a 9 volt battery. Either digital or analog meters are acceptable however most technicians find analog meters easier to use. Appropriate test leads and tips are required to test certain electronic components and connections.
- Clamp on amp meter - Should be capable of measuring from 0 to 60 amps.
- Temperature Meter - Should be high quality with thermocouple or electronic “K-type” test probe. Capable of temperature readings up to 1000 degrees Fahrenheit.

Additional instruments that a technician will need to have access to at various times include the following:

- Combustible gas leak detection meter.
- U tube manometer or equivalent testing device for measuring LP and Natural gas line pressure on gas ranges. Measurements must be in IWC (inches water column)
- Carbon Monoxide (CO) detection meter capable of measuring from 0-1000 PPM.
- Microwave Leak Detection Meter

INDUCTION COOKTOP FEATURES

A COOLER COOKTOP - A unique feature of the Induction Cooktop is whether turned ON or OFF, the cooktop surface remains cooler than standard ceramic cooktops.

MAGNETIC DETECTOR - The coil sensor automatically detects whether the pan is magnetic and eliminates accidental “turn-ONs.”

PAN SIZE DETECTION - The pan recognition sensor automatically detects and adapts the Cooking Zones to the pan sizes in use.

EFFICIENT - Induction cooking heats faster while using less energy. Induction power levels are quick to boil and when simmering provide more precise heat control.

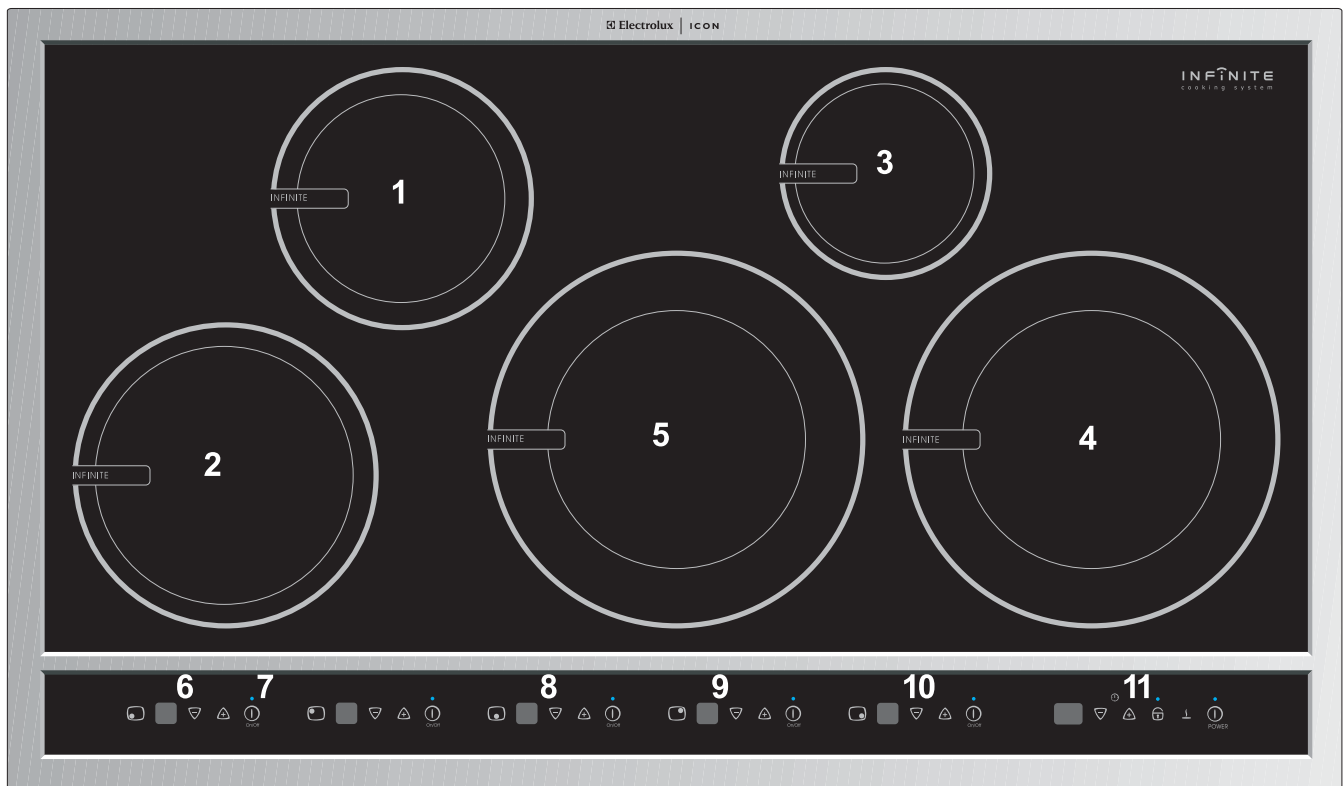

1. Left Rear Cooking Zone.
2. Left Front Cooking Zone.
3. Right Rear Cooking Zone.
4. Right Front Cooking Zone.
5. Center Cooking Zone.
6. Left Front Cooking Zone Control Pads.
7. Left Rear Cooking Zone Control Pads.
8. Center Cooking Zone Control Pads.
9. Right Rear Cooking Zone Control Pads.
10. Right Front Cooking Zone Control Pads.
11. Main Cooktop Controls (See Fig 2).

INDUCTION COOKTOP FEATURES

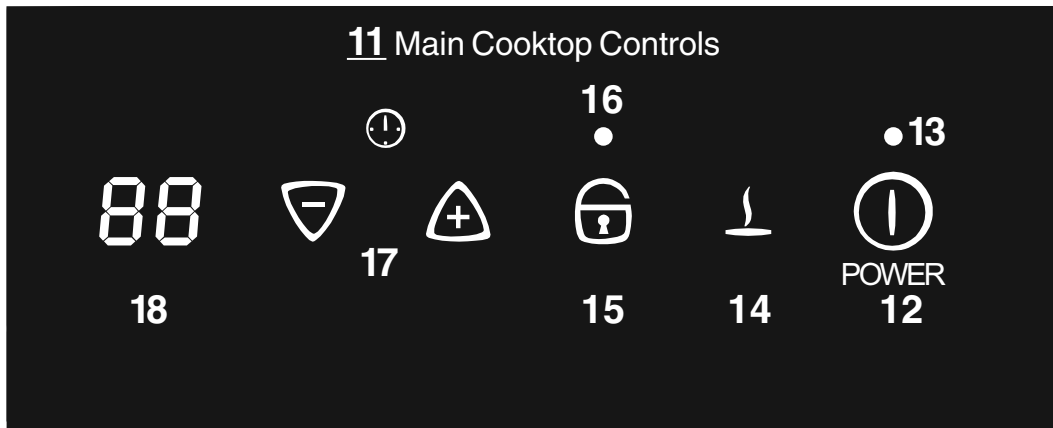

Fig2.

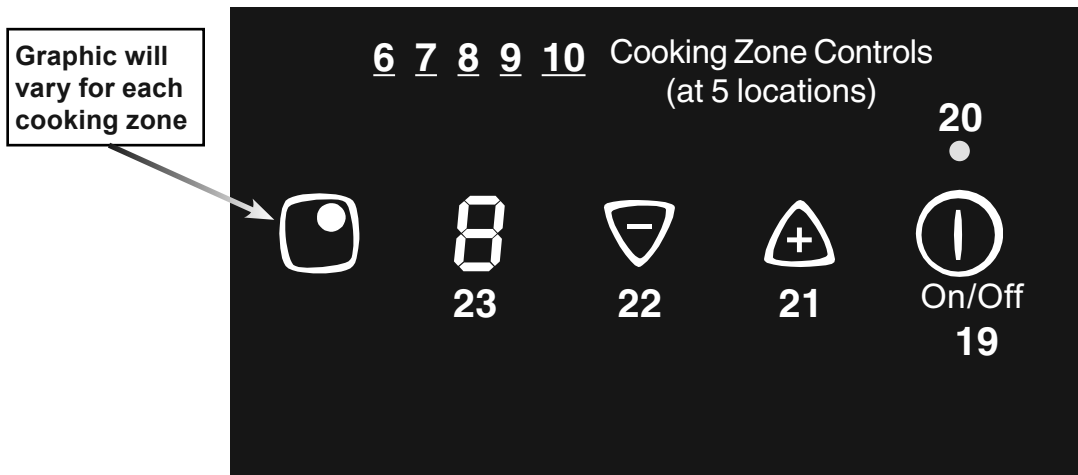
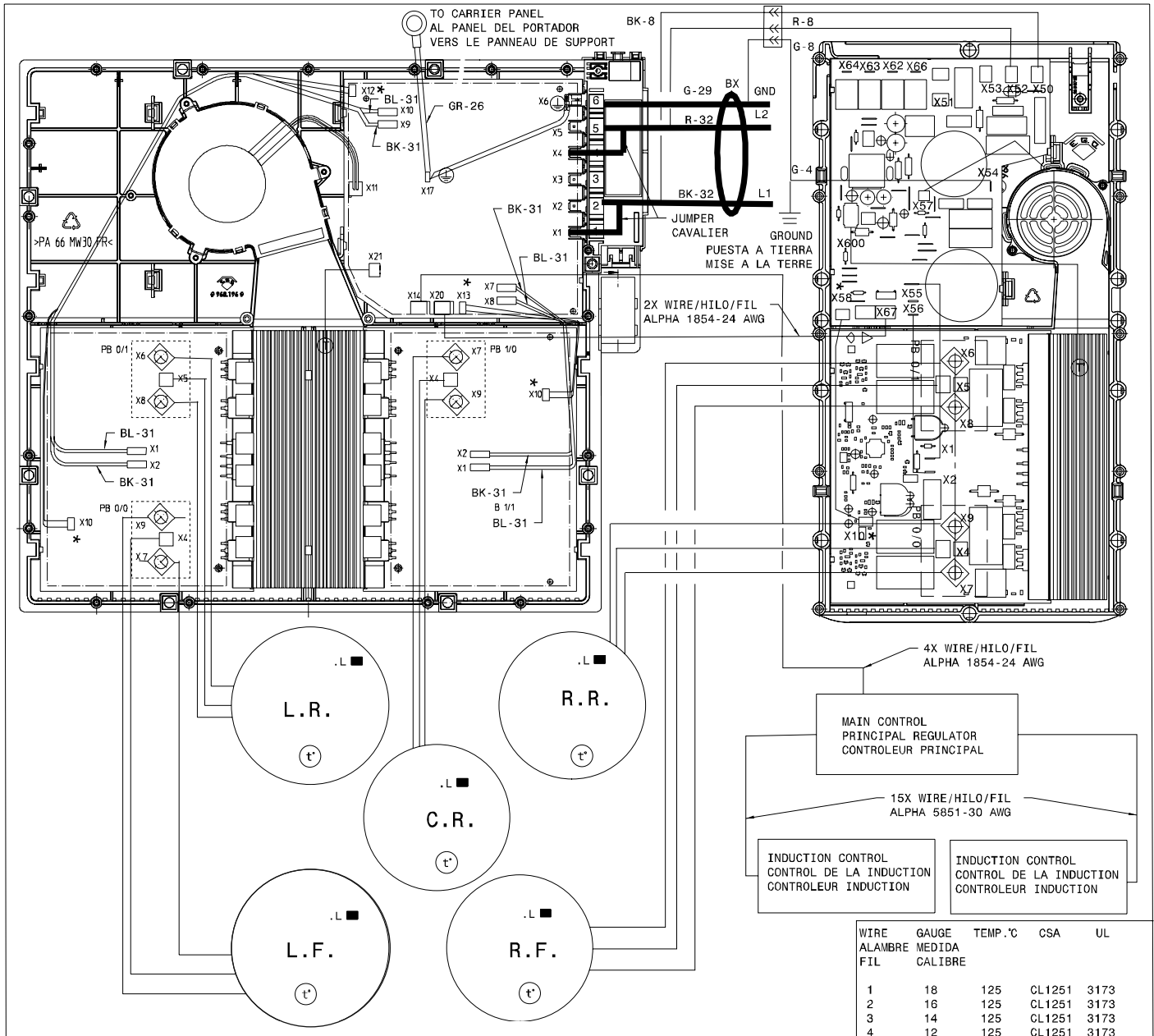

Fig3.

6. Left Front Cooking Zone Control Pads.
7. Left Rear Cooking Zone Control Pads.
8. Central Cooking Zone Control Pads.
9. Right Rear Cooking Zone Control Pads.
10. Right Front Cooking Zone Pads.
11. Main Cooktop Controls (See Fig 2).
12. Cooktop Power Key Pad (See p. 9).
13. Cooktop Power Indicator Light (See p. 9).
14. Keep Warm Setting Key Pad (See pages 10 & 16).
15. Controls Lock Key Pad (See pages 9 & 17).
16. Controls Lockout Indicator Light (See pages 9 & 17).
17. Minute Timer Setting + (increase) / - (decrease) Key Pads (See pages 16 & 17).
18. Minute Timer LED (displays up to 99 minutes - (See pages 16 & 17).
19. Cooking Zone ON/OFF Key Pad (for each Cooking Zone).
20. Cooking Zone ON/OFF Indicator Light (for each Cooking Zone).
21. Cooking Zone + (increase) Key Pad (for each Cooking Zone).
22. Cooking Zone - (decrease) Key Pad (for each Cooking Zone).
23. Cooking Zone Power Level LED (for each Cooking Zone).

INDUCTION COOKTOP WIRING DIAGRAM



PRECAUCION: LAS CONEXIONES MARCADAS CON * REQUIEREN DE UNA HERRAMIENTA ESPECIFICA PARA RETIRARLAS DEL PANEL DE CIRCUITO. SI ESTAS CONEXIONES SE RETIRAN SIN HACER USO DE ESTA HERRAMIENTA, SE PODRA DANAR LOS CABLES Y EL PANEL DE CIRCUITOS.

ATTENTION: LES CONNEXIONS MARQUEES D'UN * DOIVENT ETRE ENLEVEES AVEC UN OUTIL SPECIAL. SI CES FILS SONT ENLEVES SANS CET OUTIL, DES DOMMAGES PEUVENT ETRE CAUSES AUX FILS OU AU PANNEAU DU CIRCUIT.

LEGEND/LEYENDA/LEGENDE

SW. - SWITCH/INTERRUPTOR/INTERRUPTEUR
 P.L. - PILOT LIGHT/LAMPARA PILOTO//LAMPE TEMOIN
 R.F. - RIGHT FRONT/FRENTE DERECHO/AVANT DROIT
 R.R. - RIGHT REAR/TRASERO DERECHO/ARRIERE DROIT
 L.F. - LEFT FRONT/FRENTE IZQUIERDO/AVANT GAUCHE
 L.R. - LEFT REAR/TRASERO IZQUIERDO/ARRIERE GAUCHE
 LIM. - LIMITER/LIMITADOR/LIMITEUR
 ELM. - ELEMENT/ELEMENTO/ELEMENT
 H.S. - HOT SURFACE/SUPERFICIE CALIENTE/SURFACE CHAUDE
 T.B. - TERMINAL BLOCK/BLOQUE DE TERMINALS/BLOC DE CONNECTION
 CON. BD - CONTROL BOARD/TABLERO DE CONTROL/TABLEAU CONTROLE
 C.T. - COOK TOP/PLANCHA DE COCINAR/TABLE DE CUISSON
 t° - TEMPERATURE PROBE/SONDA DE TEMPERATURA/SONDE THERMIQUE
 .L - BOBINE/BOBINE/BOBINE

COLOR CODE/CODIGOS/CODE DE COULEUR

G. - GREEN/VERDE/VERT
 W. - WHITE/BLANCO/BLANC
 R. - RED/ROJO/ROUGE
 O. - ORANGE/MARANJA/ORANGE
 Y. - YELLOW/AMARILLO/JAUNE
 BR. - BROWN/MORENO/BRUN
 BL. - BLUE/AZUL/BLEU
 BK. - BLACK/NEGRO/NOIR
 PK. - PINK/ROSA/ROSE

WIRE ALAMBRE FIL	GAUGE MEDIDA CALIBRE	TEMP. °C	CSA	UL
1	18	125	CL1251	3173
2	16	125	CL1251	3173
3	14	125	CL1251	3173
4	12	125	CL1251	3173
5	18	150	EXL-150	3321
6	16	150	EXL-150	3321
7	14	150	EXL-150	3321
8	12	150	EXL-150	3321
9	10	150	EXL-150	3321
10	18	200	SEW-1	3122
11	16	200	SEW-1	3122
12	12	250		3252
13	16	250		3252
14	20	150	EXL-150	3321
15	8	150	EXL-150	3321
16	8	60		
17	10	60		
18	10	200	SEW-1	3122
19	20	125	SEW-1	3173
20	20	200	SEW-1	3122
21	22	125	CL-1252	3266
22	22	150		10109
23	18	200		3573
24	20	105		1015
25	18	105		1015
26	16	105		1015
27	14	105		1015
28	12	105		1015
29	10	105		1015
30	22	105		1569
31	16	200		3135
32	8	105		1015

CAUTION: DISCONNECT POWER BEFORE SERVICING UNIT.
 ATENCION: CORTAR EL CORRIENTE ANTES DE REALIZAR EL MANTENIMIENTO DEL ELECTRODOMESTICO.
 ATTENTION: COUPEZ L'ALIMENTATION AVANT D'EFFETUER LA REPARATION.

318046823 REV: B

INSTALLATION INSTRUCTIONS

**INSTALLATION AND SERVICE MUST BE PERFORMED BY A QUALIFIED INSTALLER.
IMPORTANT: SAVE FOR LOCAL ELECTRICAL INSPECTOR'S USE.
READ AND SAVE THESE INSTRUCTIONS FOR FUTURE REFERENCE.**

! WARNING FOR YOUR SAFETY: Do not store or use gasoline or other flammable vapors and liquids in the vicinity of this or any other appliance.

IMPORTANT INSTALLATION INFORMATION

- All electric cooktops run off a single phase, three-wire or four-wire cable, 240/208 volt, 60 hertz, AC only electrical supply with ground.
- Minimum distance between cooktop and overhead cabinetry is 30" (76.2 cm).

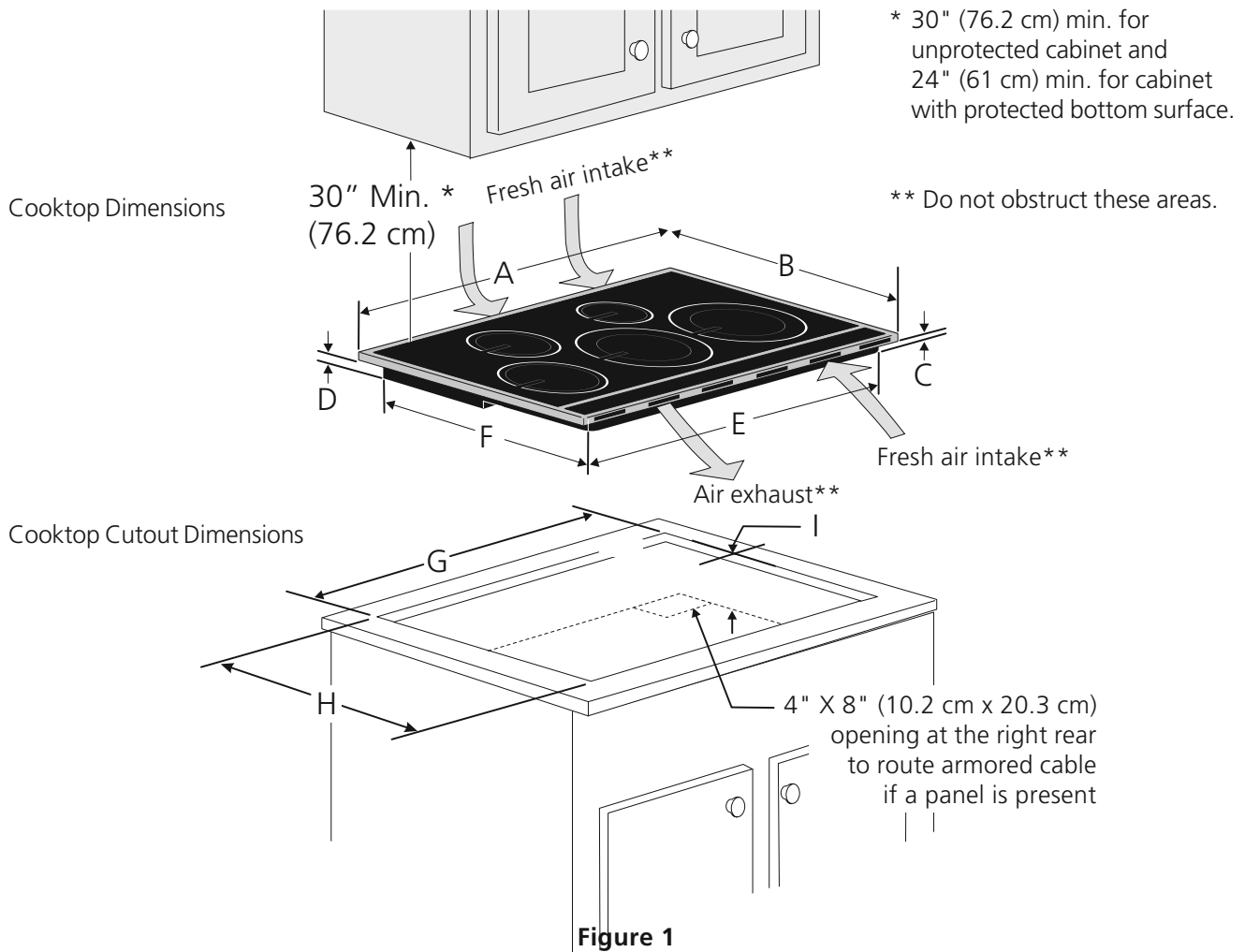

COOKTOP DIMENSIONS						CUTOUT DIMENSIONS				
A. LENGTH	B. WIDTH	DEPTH		E. LENGTH	F. WIDTH	G. LENGTH		H. WIDTH		I. DEPTH
		C	D			Min.	Max.	Min.	Max.	
36¾ (93.3)	21½ (54.6)	2 (5.1)	2¾ (7)	34⅝ (87.9)	19⅞ (50.5)	35⅞ (91.1)	36 (91.4)	20⅝ (51.8)	20½ (52.1)	4½ (11.4)

All dimensions are stated in inches and (cm).

Allow 2" (5 cm) space below the armored cable opening to clear the electric cable and allow space for installation of the junction box on the wall at the back of the cooktop.

INDUCTION COOKTOP INSTALLATION INSTRUCTIONS

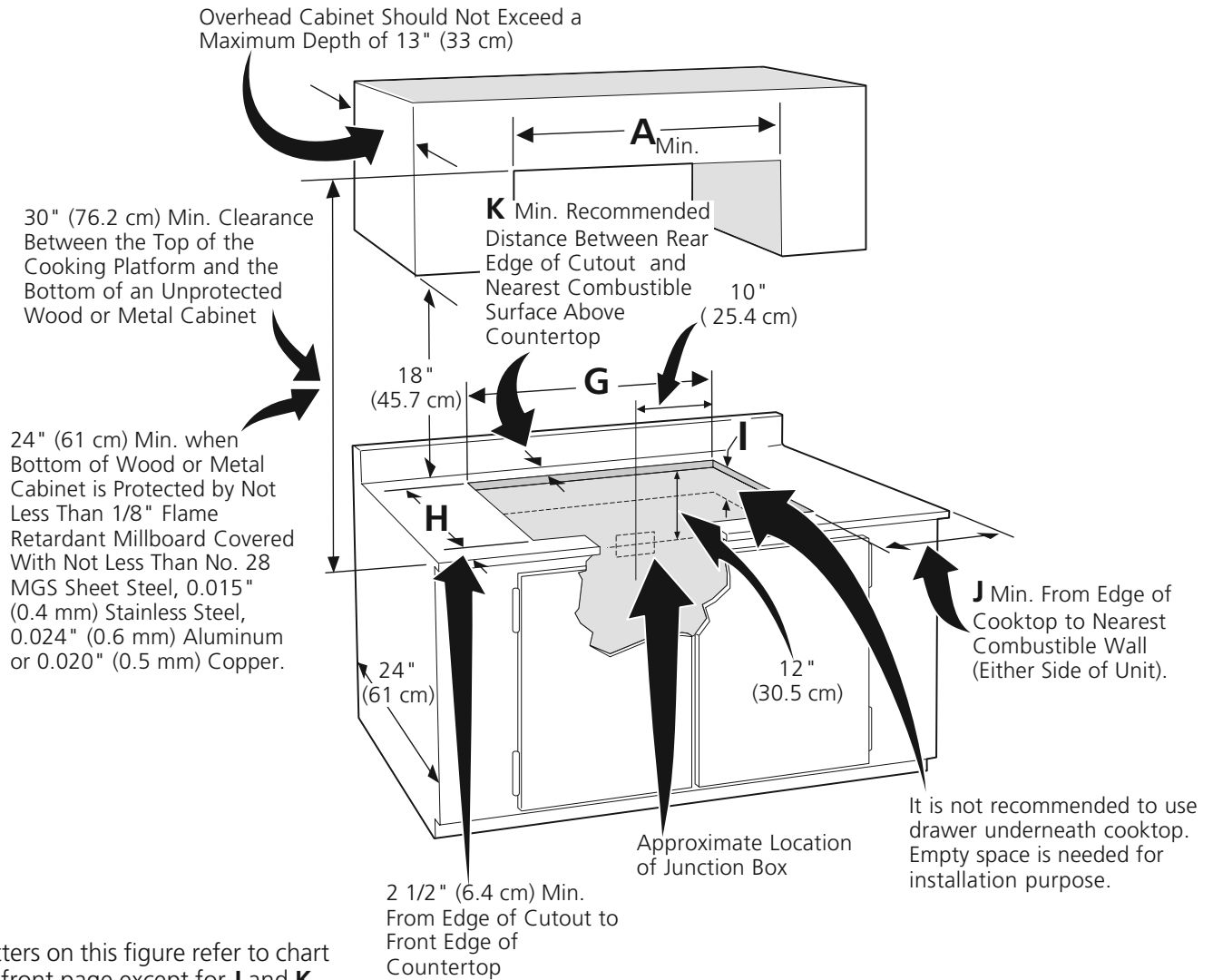

CAUTION To eliminate the risk of burns or fire by reaching over heated surfaces, cabinet storage space located above the cooktop should be avoided. If cabinet storage is provided, risk can be reduced by installing a range hood that projects horizontally a minimum of 5" (12.7 cm) beyond the bottom of the cabinets.

MODEL	J	K
36"	7½" (19.1 cm)	2" (5.1 cm)

Figure 2 – COUNTERTOP CUTOUT OPENING

INDUCTION COOKTOP INSTALLATION INSTRUCTIONS

Important Notes to the Installer

1. Read all instructions contained in these installation instructions before installing the cooktop.
2. Remove all packing material before connecting the electrical supply to the cooktop.
3. Observe all governing codes and ordinances.
4. Be sure to leave these instructions with the consumer.
5. Only certain cooktop models may be installed over certain built-in electric oven models. Approved cooktops and built-in ovens are listed by the MFG ID number and product code. (Refer to the Information Sheet for the model numbers).

Important Note to the Consumer

Keep these instructions with your Use and Care Guide for future reference.

IMPORTANT SAFETY INSTRUCTIONS

- **Be sure your cooktop is installed and grounded properly by a qualified installer or service technician.**
- **This cooktop must be electrically grounded in accordance with local codes or, in their absence, with the National Electrical Code ANSI/NFPA No. 70—latest edition in the United States.**

⚠ WARNING The electrical power to the cooktop must be shut off while line connections are being made. Failure to do so could result in serious injury or death.

Provide Electrical Connection

Install the junction box under the cabinet and run 120/240 or 120/208 Volt, AC wire from the main circuit panel. NOTE: DO NOT connect the wire to the circuit panel at this time.

Electrical Requirements

Observe all governing codes and local ordinances.

1. A 3-wire or 4-wire single phase 120/240 or 120/208 Volt, 60 Hz AC only electrical supply is required on a separate circuit fused on both sides of the line (time-delay fuse or circuit breaker is recommended). DO NOT fuse neutral. The fuse size must not exceed the circuit rating of the appliance specified on the nameplate.
2. A circuit breaker or fuse rated at 50 Amp is recommended for this appliance.

NOTE: Wire sizes and connections must conform with the fuse size and rating of the appliance in accordance with the National Electrical Code ANSI/NFPA No. 70—latest edition and local codes and ordinances.

⚠ WARNING An extension cord must not be used with this appliance. Such use may result in a fire, electrical shock, or other personal injury.

3. The appliance should be connected to the fused disconnect (or circuit breaker) box through flexible armored or nonmetallic sheathed cable. The flexible armored cable extending from this appliance should be connected directly to the grounded junction box. The junction box should be located as shown in Figure 2 with as much slack as possible remaining in the cable between the box and the appliance, so it can be moved if servicing is ever necessary.
4. A suitable strain relief must be provided to attach the flexible armored cable to the junction box.

Unpacking Instructions

1. Unpack and visually inspect the cooktop.
2. Be sure the bottle of cleaner conditioner packed in the literature bag is left where the user can find it easily. It is important that the ceramic-glass cooktop be pretreated before use. See **Cooktop Cleaning and Maintenance** section in the **Use and Care Guide**.

Electrical Connection

Connect the flexible armored cable that extends from the surface unit to the junction box using a suitable strain relief at the point the armored cable enters the junction box. Then make the electrical connection as follows.

Electrical ground is required on this appliance.

⚠ WARNING This appliance is equipped with a copper conductor flexible cable. If connection is made to aluminum house wiring, use only special connectors which are approved for joining copper and aluminum wires in accordance with the National Electrical Code and local codes and ordinances. Improper connection of aluminum house wiring to copper leads can result in a short circuit or fire. Follow the connector manufacturer recommended procedure closely.

This appliance is manufactured with a supply wire and a frame connected green or bare copper grounding wire.

INDUCTION COOKTOP INSTALLATION INSTRUCTIONS

⚠ WARNING DO NOT ground to a gas supply pipe. DO NOT connect to electrical power supply until appliance is permanently grounded. Connect the ground wire before turning on the power.

Where local codes permit connecting the appliance-grounding conductor to the neutral (white) wire (see figure 3):

1. Disconnect the power supply.
2. In the circuit breaker, fuse box or junction box, connect appliance and power supply cable wires as shown in figure 3.

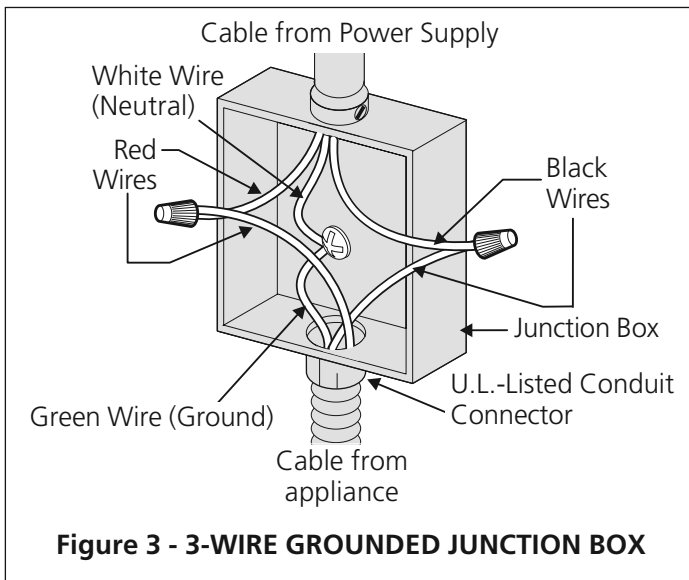

⚠ WARNING You may not ground the cooktop through the neutral (white) wire if cooktop is used in a new branch circuit installation (1996 NEC), mobile home, recreational vehicle, or where local codes do not permit grounding to the neutral (white) wire. When grounding to the neutral (white) wire is prohibited, you must use a 4-wire power supply cable. See Figure 4. Failure to heed this warning may result in electrocution or other serious personal injury.

If cooktop is used in a new branch circuit installation (1996 NEC), mobile home, recreational vehicle, or where local codes DO NOT permit grounding to the neutral (white) wire (see figure 4):

1. Disconnect the power supply.
2. In the circuit breaker, fuse box or junction box, connect appliance and power supply cable wires as shown in figure 4.

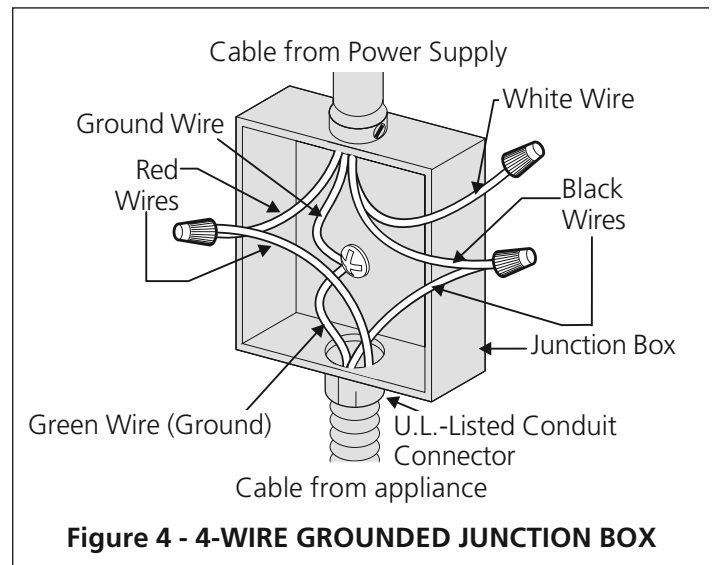

⚠ WARNING If connecting to a 4-wire power supply cable electrical system, the appliance frame connected ground wire **MUST NOT** be connected to the neutral wire of the 4-wire electrical system.

NOTE TO ELECTRICIAN: The armored cable leads supplied with the appliance are UL-listed for connection to larger gauge household wiring. The insulation of the leads is rated at temperatures much higher than temperature rating of household wiring. The current carrying capacity of the conductor wire is governed by the temperature rating of the insulation around the wire, rather than the wire gauge alone.

INDUCTION COOKTOP INSTALLATION INSTRUCTIONS

Cooktop Installation

1. Visually inspect the cooktop for damage. Also make sure all cooktop screws are tight (see Figure 5).

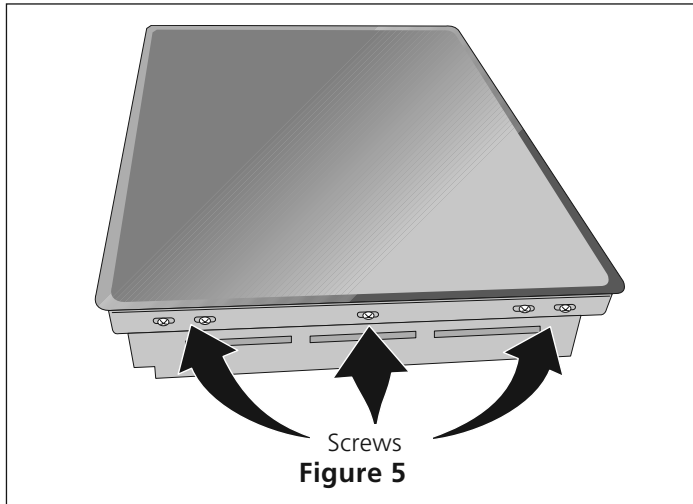

2. Install the retainer brackets. See Figure 6.

The retainer brackets **MUST** be installed, to meet local codes or, in their absence, with the National Electrical Code ANSI/NFPA No. 70—latest edition (see Figure 6).

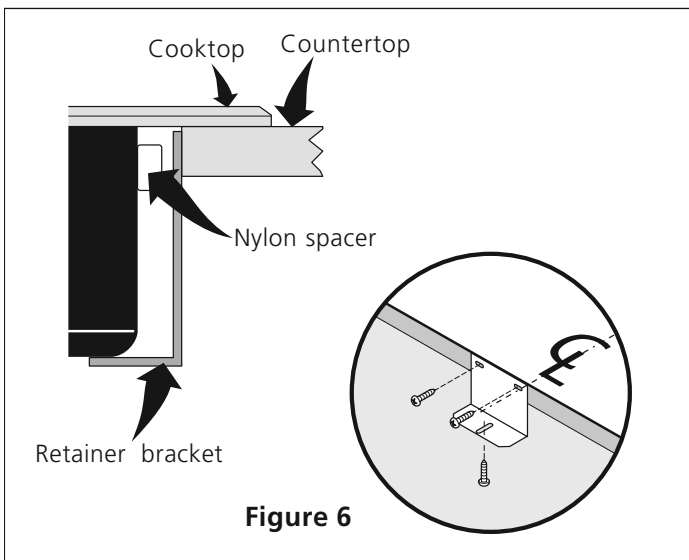

3. Set the cooktop into the countertop cutout.

NOTE: Do not use caulking compound; cooktop should be removable for service when needed.

⚠ WARNING Do not remove the nylon spacers on the edges of the cooktop. These spacers center the cooktop in the space provided. The cooktop must be centered to prevent excess heat buildup that may result in heat damage or fire (see Figure 7).

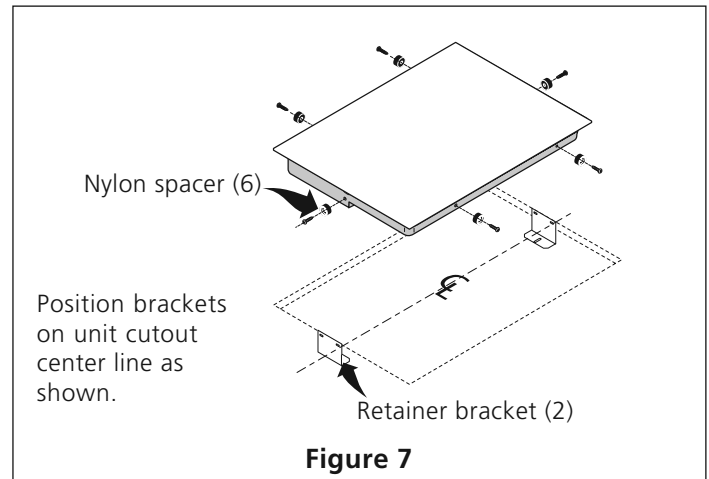

Checking Operation

Refer to the **Use and Care Guide** for operation.

⚠ CAUTION Do not touch cooktop glass or elements. They may be hot enough to burn you.

Model and Serial Number Location

The serial plate is located under the cooktop.

When ordering parts for or making inquiries about your cooktop, always be sure to include the model and serial numbers and a lot number or letter from the serial plate on your cooktop.

Before You Call for Service

Read the Before You Call for Service Checklist and operating instructions in your **Use and Care Guide**. It may save you time and expense. The list includes common occurrences that are not the result of defective workmanship or materials in this appliance.

Refer to your **Use and Care Guide** for service phone numbers.

INTRODUCTION TO INDUCTION COOKING

How Induction Cooking Works

Induction cooking uses high frequency magnetic energy to heat the cooking utensil when it is placed over the induction coil. The induction fields have no affect on non magnetic surfaces such as paper, plastic, glass, ceramic, or non ferrous metals like aluminum, copper etc.

An induction cooking system requires two key components to operate.

The first component is the induction coil or element. This coil generates the magnetic induction field needed for induction cooking.

The second key component is the cooking utensil or pan with a bottom constructed of material that will attract a magnet.

If a magnet will not stick to the bottom of the pan it can not be used for induction cooking.

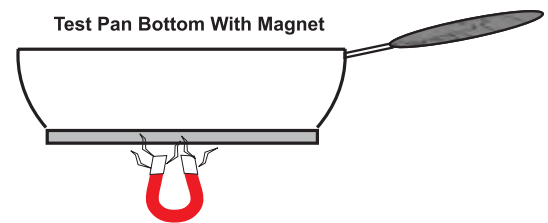

When the proper type of pan is placed over the induction coil and the coil is energized it generates a field of magnetic waves that cause the bottom of the pan to heat.

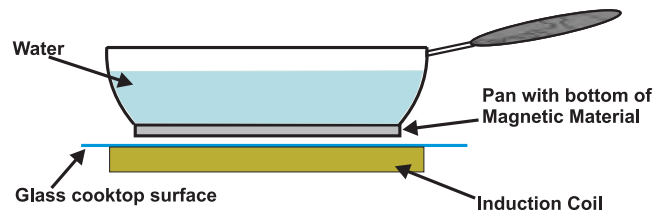

Induction cooking is highly efficient since the energy created by the induction fields is not wasted by heating the glass and surrounding area of the cooktop surface.

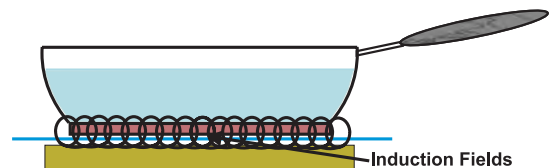

Due to this increased efficiency the contents of the pan are heated more quickly than with gas burners or traditional radiant electric and coil elements.

Since the induction fields heat only into the cooking utensil the surrounding surface remains cooler than with traditional cooktops.

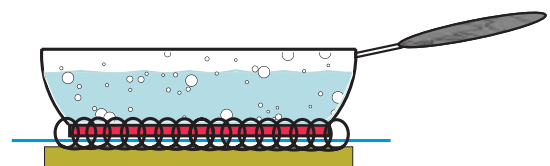

SELECTING PROPER COOKWARE

Determining Pan Size

When selecting a pan to use for induction cooking it is important to know the correct size of the pan in order to determine the proper cooking zone to be used. The size of the magnetic portion of the pan bottom has a direct effect on the cooking performance and efficiency of the cooking zone. Pan design and construction vary widely as can be seen by the examples given below.

The following illustrations show some of the variations found in the construction of pan bottoms.

Fig. A

The overall diameter of this pan is 9 inches if measured at the top portion. The flat magnetic portion of the bottom (shaded in gray) is only 7 inches in diameter. This pan would be considered to be a 7 inch pan and should be used on a cooking zone appropriate for this size.

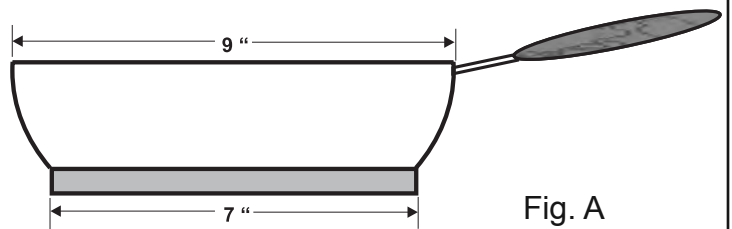

Fig. A

Fig. B

The bottom of this pan is a non magnetic alloy with an encapsulated inner core of magnetic material. The inner magnetic core is 1 inch smaller than the outer dimension of the flat pan bottom. This pan will have different cooking characteristics than the pan in [Fig. A](#). The effective cooking diameter of this pan is 6 inches.

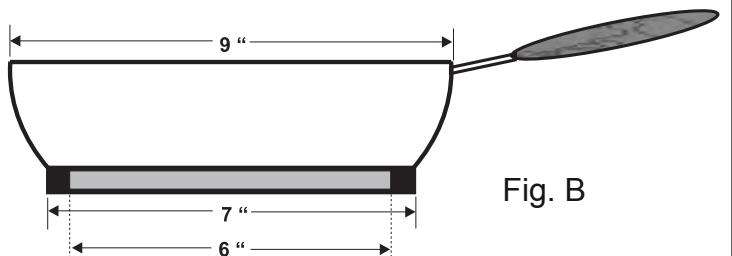

Fig. B

Fig. C

This pan has a bottom of non magnetic alloy with a different shaped encapsulated inner magnetic core. The illustration shows that the core is thinner near the outer perimeter of the pan bottom and increases in thickness as it nears the center of the pan. This type of pan will have different cooking characteristics than a pan with a uniform core thickness.

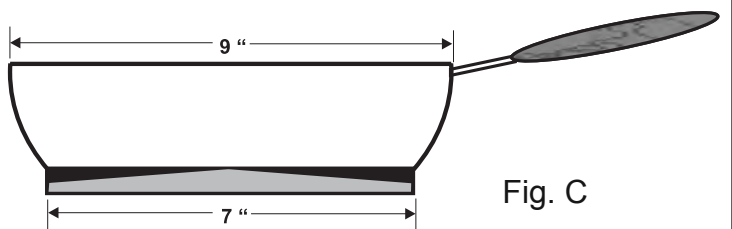

Fig. C

Inspecting Pan Bottom

For best results with an induction cooktop the pan bottom should be as flat as possible with no deep grooves or ridges on the bottom surface. Pans that are not flat or that have grooves or ridges on the bottom will not be as efficient as smooth, flat bottomed pans.

To see if the pan is flat place a ruler or similar straight edge against the bottom of the pan.

A pan that is perfectly flat will have no visible space between the ruler and the bottom of the pan.

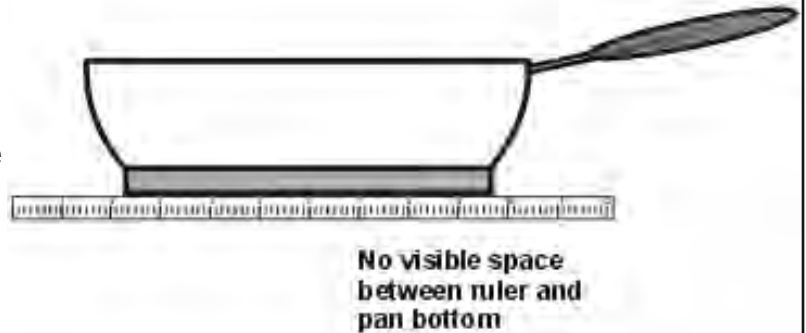

If the cookware is severely warped or bowed it may not function on the induction cooktop.

Cookware in this condition may not activate the pot detection feature of the cooking zone.

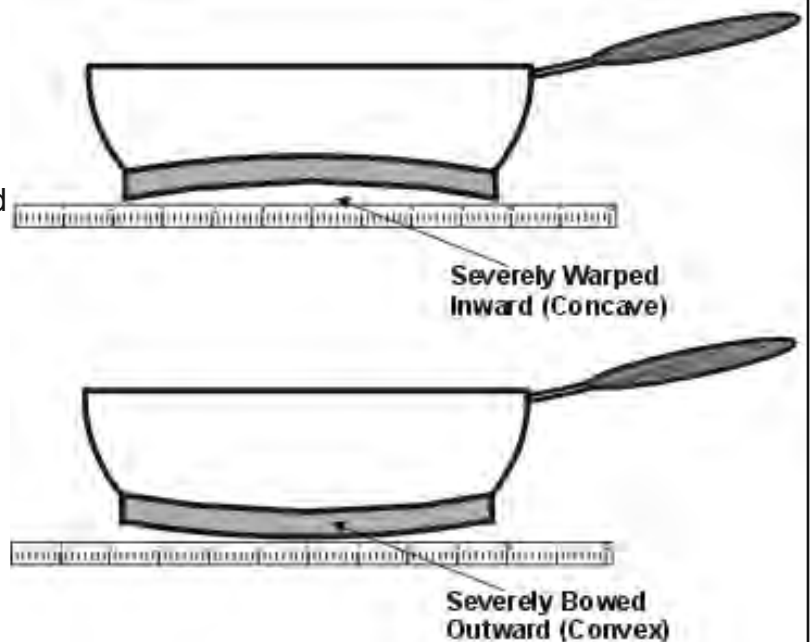

INDUCTION COOKTOP DISPLAY MESSAGES

LED MESSAGES OR LIGHT INDICATORS DISPLAYED BY MAIN CONTROL

CONTROLS LOCK - This feature allows the cooktop to be locked only when the cooktop is switched to OFF. Touch and hold the LOCK key pad for 5 seconds. A beep will sound and the Lock indicator light will glow (Fig. 5). Once locked, no other displays will glow and no Cooking Zones will activate. To turn the Controls Lock OFF, touch and hold the LOCK key pad for 5 seconds. A beep will sound, the Lock indicator light will turn OFF (Fig. 4) and the cooktop may be used normally.



Fig. 4



Fig. 5

COOKTOP POWER - The Cooktop POWER key pad activates the entire Cooktop. To power the cooktop, touch and hold the POWER key pad for 2 seconds. A beep will sound and the Power LED will glow (See Fig. 7). The cooktop will be in a ready mode for 10 seconds. If no other key pads are touched the Cooktop Main POWER will turn OFF automatically. To turn the Main Power OFF touch and hold the Main POWER key pad for 1 second. A beep will sound and the Power indicator Light will turn OFF (See Fig. 6).

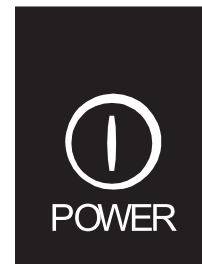

Fig. 6

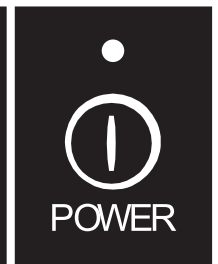

Fig. 7

Errors Codes E XX - The control displays **E** in Cooking Zones LEDs (Fig. 8) and digits in Main Control LED (Fig. 9) together showing an error code.



Fig. 8



Fig. 9

LED MESSAGES OR LIGHT INDICATORS DISPLAYED BY COOKING ZONE CONTROLS

COOKING ZONE ON/OFF PAD - Each of the five Cooking Zones have separate ON/OFF key pads. Once the Main Power key pad has been touched to activate the cooktop, touch the corresponding Cooking Zone ON/OFF key pad once to activate the Cooking Zone needed. 0 will appear in the LED display. If the corresponding + (increase) / - (decrease) key pad is not touched within 10 seconds, the request to turn the Cooking Zone ON will cancel and the Cooktop Main Power will turn OFF. To set a Cooking Zone power level touch the corresponding Cooking Zone + (increase) or - (decrease) key pad once. The Cooking Zone ON/OFF Indicator Light will glow (Fig. 11). To turn OFF a Cooking Zone, touch the Cooking Zone ON/OFF key pad once. The Cooking Zone Indicator Light will turn OFF (Fig. 10).



Fig. 10

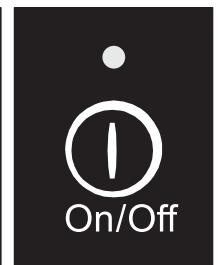

Fig. 11



Fig. 12



Fig. 13

INDUCTION COOKTOP DISPLAY MESSAGES

LED MESSAGES OR LIGHT INDICATORS DISPLAYED BY COOKING ZONE CONTROLS (CONT'D)



Fig. 14

POWER LEVEL SETTINGS - The Cooking Zones have five separate Power Level LEDs. Once active, the Cooking Zones will provide 10 Power Levels to choose from. These include **1 2, 3, 4, 5, 6** (fig. 14), **7, 8, 9**. The highest setting of **P** or “**Power Boost**” provides 125% power level for 10 minutes (See Fig. 13). Each key pad touch (or just holding down the Power Level key pad) will scroll through all the available power levels for any Cooking Zone quickly (See owners manual for complete instructions).



Fig. 15

RESIDUAL HEAT - Once any Cooking Zone has been used for cooking and turned OFF, and if the cooktop surface temperature on any of the Cooking Zones is still too HOT, H (See Fig. 15) will appear in the LED display for the affected Cooking Zone. The H will continue to display if the temperature is still too HOT.



Fig. 16

KEEP WARM - Use the WARM (or LOW) key pad to activate the Warm setting for any of the Cooking Zones. The ON/OFF key pad for the desired Cooking Zone must be activated first, then touch the WARM key pad located in the Cooktop Main Control area once to set. L (LOW) should appear in the corresponding Cooking Zone LED (See Fig. 16).



Fig. 17

PAN DETECTION - All five Cooking Zones will provide a Pan Detection message. If a Cooking Zone is turned ON and no pan is detected for the Cooking Zone, the pan has been moved or if the pan is not centered correctly or if the pan is not made of magnetic material, F (See Fig. 17) will appear in the affected Cooking Zone LED display.

BASIC OPERATION

USING THE TOUCH CONTROL



Fig. 22







The recommended way to use the touch pads on the cooktop is shown in Fig. 22. Be sure that your finger is placed in the center of the touch pad as shown. If the finger is not placed on the center of a pad, the cooktop may not respond to the selection made.

Lightly contact the pad with the flat part of your entire fingertip. Do not just use the narrow end of your fingertip.

OPERATING THE COOKING ZONES

The Induction cooktop has five Cooking Zones designed for cookware of various sizes. Be sure to place cookware that meets the minimum and maximum pan size requirements (Fig. 19) for the Cooking Zone desired and is best for the amount of food being prepared. Place the cookware with the prepared food on the Cooking Zone **BEFORE** setting any of the Cooktop controls.





To Turn ON one or more of the Cooking Zones:

1. Place the prepared food using the correct type and size cookware on the desired Cooking Zone. Be sure to center the cookware on Cooking Zone completely covering the minimum ring marked on the Zone surface. PLEASE NOTE: If the cookware requirements for the Cooking Zone (See Fig. 20) are not met the sensors will detect a problem and display the letter **F** in the affected Cooking Zone LED. Any problems must be corrected before proceeding.
2. Touch and hold the  key pad for 2 seconds (or until a beep sounds). The Power Indicator light located above the  key pad will turn ON. NOTE: If no other key pad is touched within 20 seconds the request to Power ON the cooktop will clear.
3. To start one or more of the five Cooking Zones lightly touch the  key pad for the Cooking Zones needed. A beep will sound and the chosen Cooking Zone power level digital display will show **0** indicating no power level for the Zone has been set yet. NOTE: If no other key pad is touched within 10 seconds the request to Power ON the Cooktop Zone will clear.
4. Set the desired power level for the Cooking Zone by touching either the  or  key pad. If the  key pad is touched the Cooking Zone will start at a "Power Boost" maximum power level (the Cooking Zone LED will display **P** and the control will beep once). If the  key pad is touched once the Cooking Zone will start at 1 (the Cooking Zone LED will display **1** and the control will beep once).

BASIC OPERATION

OPERATING THE COOKING ZONES (CONT'D)



To Turn ON one or more of the Cooking Zones (cont'd)

NOTE: Touch once, or repeatedly touch the  or  key pads to adjust or scroll through power levels at any time during the cooking process (To scroll through the power levels quickly touch and hold the  or  key pads until the power level desired is reached). Once the Cooking Zone power level has been set the food will begin to heat at that level until the power level is manually changed. For more information about the available Cooktop Zones power levels available see “Power Level Settings” section on page 10.

IMPORTANT OPERATING NOTES:

- Fluids spilled or objects lying on the controls area of the cooktop may cause the cooktop to display error code and turn OFF while cooking. Clean the spills or remove the objects from the cooktop.
- Be sure the cooktop vent holes are NOT blocked. If the vent holes are blocked the cooktop internal sensor may shut OFF of the cooktop to avoid over heating the appliance.
- If the cookware or pan is moved from the center of any active Cooking Zone for any reason, a sensor will detect the situation and the cookware will no longer heat. The affected Cooking Zone LED will flash between **F** and the last power level set for the Cooking Zone. The Cooking Zone will remember the power level setting for up to 3 minutes before the Cooking Zone will automatically shut OFF.

To Turn OFF the Cooking Zones:

1. Once cooking is complete, touch the  key pad to turn the Cooking Zone OFF.
2. The corresponding Cooking Zone ON/OFF Indicator light located above the  key pad will turn OFF. A beep will sound and the chosen Cooking Zone power level LED will display **0**. If no other key pads are touched the Cooking Zone will shut OFF automatically in 10 seconds. If no other Cooking Zones are active and no other key pads are touched the entire cooktop will shut OFF automatically in 20 more seconds.
3. When any Cooking Zone is OFF, the corresponding Cooking Zone LED may display **H** if the Cooking Zone temperature is too HOT. The LED will continue to display **H**, and even if the Cooktop is switched OFF the LED will continue to display **H** as long as the cooktop remains HOT.

CAUTION

The Cooking Zones may appear to be cool while turned ON and after they have been turned OFF. **The glass surface may be HOT** from residual heat transferred from the cookware and burns may occur.

BASIC OPERATION

PREHEAT RECOMMENDATIONS



When preheating a pan on the cooktop always watch carefully. Whenever using the cooktop the user should always pay attention to any items cooking and remain attentive until the cooking process is complete.

Keep in mind that induction may decrease the amount of time required to preheat a cooking utensil.

KEEP WARM FEATURE

The Warm feature may be used with any of the Cooking Zones.





To Turn the Keep Warm Feature ON:

1. To select the Keep Warm feature for any Cooking Zone touch the  key pad for the corresponding Cooking Zone.
2. Touch the  key pad located in the main control area. The Cooking Zone will display **L** (LOW) indicating that the Cooking Zone is properly set to Keep Warm. If no other key pads are pressed for a period of 5 seconds the control will activate the desired Cooking Zone at the Keep Warm setting (See Fig. 16).

MINUTE TIMER

The Minute Timer feature may be useful in the kitchen if a recipe calls for keeping track of time. This feature will keep track of time from 1 to 99 minutes. The LED display located to the left of the Timer UP/DOWN arrow key pads will begin to count down minutes once set.

To Set the Minute Timer:

1. Touch the  listed under the symbol . Touching and releasing the  or the  key pads will increase or decrease the Minute Timer setting by 1 minute with each key press (up to **99** minutes).
2. Once the Timer LED displays the desired amount of time, release the UP or DOWN Arrow key pads. The Minute Timer LED will flash the time with a small dot to the right. Once the LED quits flashing and the dot disappears the Minute Timer will begin the countdown with remaining minutes. Once the Minute Timer reaches **00** a long beep will sound indicating that the time is up.

COMPONENT ACCESS AND SERVICE PROCEDURES

⚠ WARNING DISCONNECT OR TURN OFF ALL ELECTRICAL POWER AND GAS SUPPLY BEFORE SERVICING APPLIANCE

To gain access to the various component parts of the cooktop assembly it must be uninstalled from the cabinet and counter top. Depending on the location of the power supply junction box it may also be necessary to disconnect the cooktop power flex cable from the junction box.

Remove the screws securing the cooktop to the mounting brackets and lift the cooktop assembly out of the cut out in the counter. Place the cooktop assembly on a stable protected work surface. Use wooden blocks or other suitable material as spacers to support the cooktop assembly from below and avoid pressure on the power cable strain relief.

Removing Cooktop Glass

Begin disassembly by removing the side heat shields (Fig 21) found on each side of the cooktop chassis. These shields must be replaced prior to reinstalling the unit into the cabinet. Note that the 90 degree flange on the shield goes up next to the cooktop glass. Next remove the five screws indicated by the arrows in the photo (Fig 21A) and remove the vent deflector at the front edge of the cooktop.

Remove the remaining screws that secure the cooktop glass and frame to the burner box (Fig 21B). Lift the rear edge of the cooktop glass and tilt it toward you to access the touch control harness plug (Fig 17c). Disconnect the plug from the control edge connector. The control will remain secured to the cooktop glass.

Carefully lift the cooktop glass and frame away from the assembly.

NOTE: It is not necessary to remove the screws that secure the plastic spacers found on the left and right hand sides of the cooktop.

With the glass top and frame removed the induction coils and insulation pad are accessible for service. (Fig.21D)

Use care when handling the induction coils and insulation panel to prevent damage.

! CAUTION !

When handling or servicing electronic parts follow proper procedures to avoid component damage due to static discharge

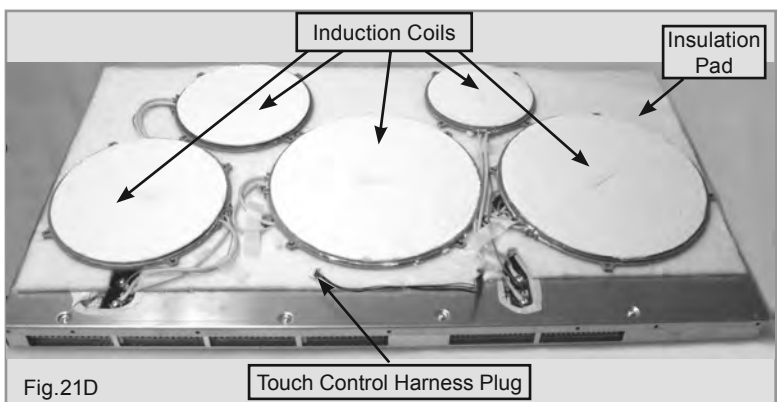
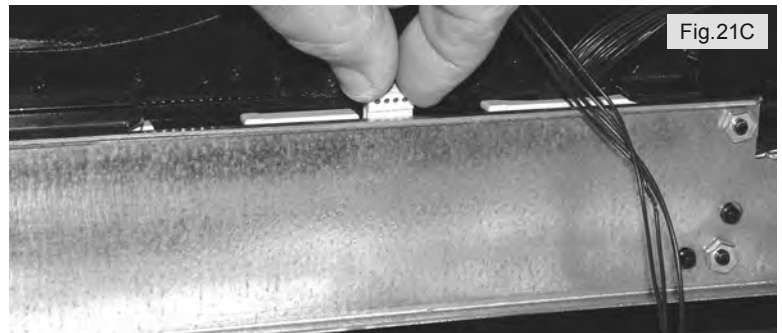
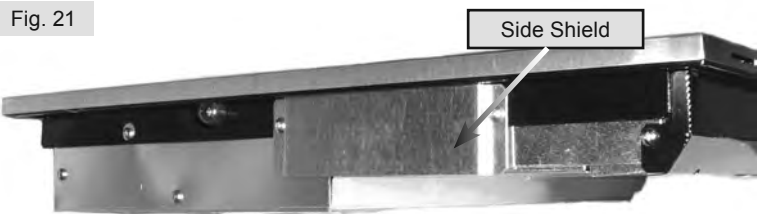

COMPONENT ACCESS AND SERVICE PROCEDURES

Removing Touch Control Boards

The cooking zone touch control boards and main control board are secured to the cooktop glass by a metal cover plate (Fig 22). To access the controls remove the nuts that secure the plate to the cooktop glass.

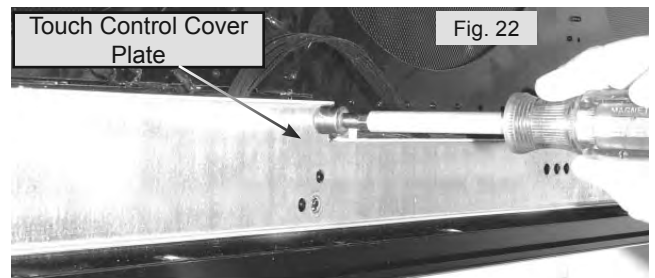

The touch control board for the Left Front and Left Rear cook zones is identical to the Center and Right Rear cook zone control board. The control board for the Right Front cook zone includes the main power control and minute timer. Each wire harness connecting the three touch control boards is replaced as a separate component.

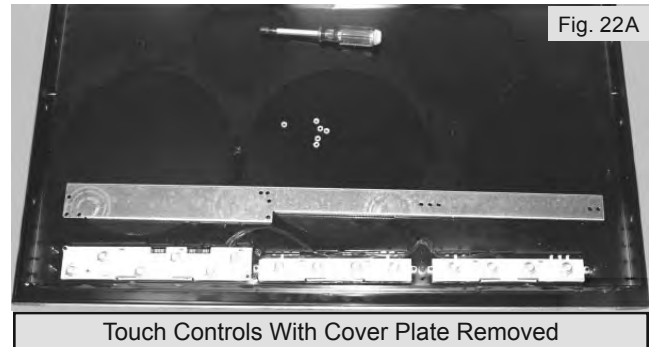

After removing the metal cover plate lift off the nylon spacers found on the threaded studs (Fig 22B). Gently lift the touch control boards off the studs and away from the glass assembly. The individual touch control boards and wire harnesses can now be serviced or replaced.

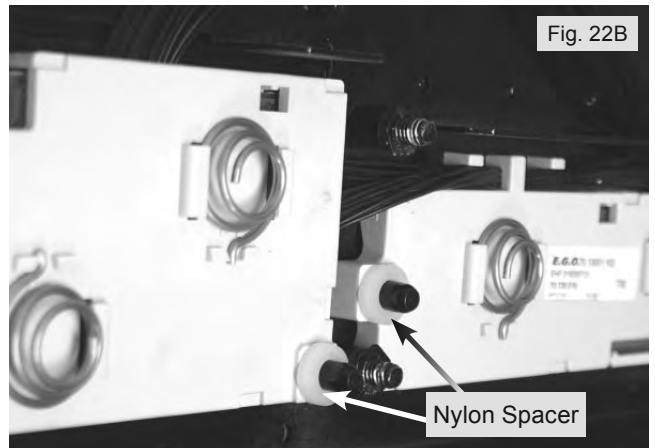

Touch Control Board Wiring

The photo below illustrates the wiring connections between the Cook Zone controls and the Main Power Control. Note that on the main power control edge connectors X4 & X5 are identical. Either of these can be used to connect the cable from the filter board. Edge connector X3 is not used.

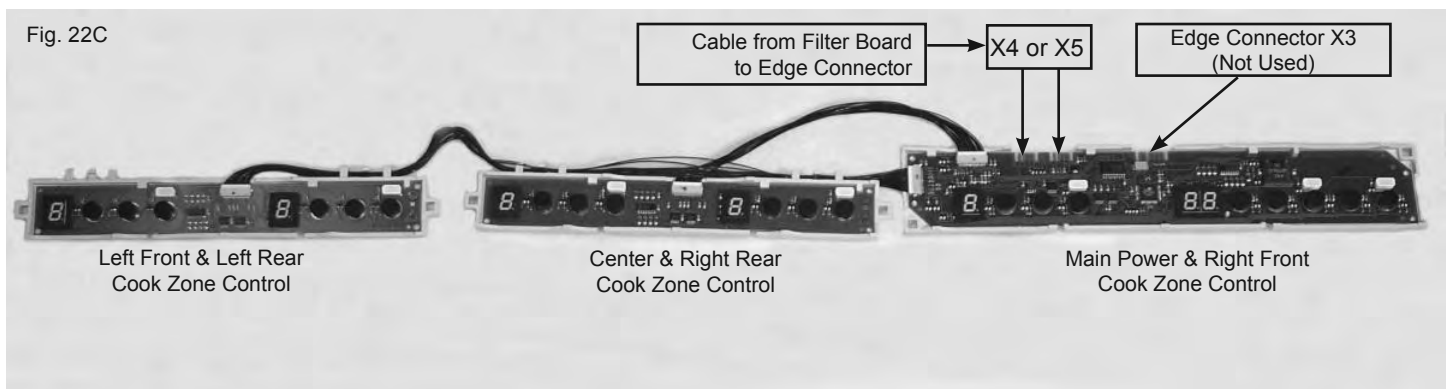

COMPONENT ACCESS AND SERVICE PROCEDURES

Removing Induction Coils

Using a # 25 torx screwdriver loosen the screw terminals on the power board and remove the wires to the induction coil. (Fig. 23)

The terminals are forked and can be removed without completely removing the screw.

With the induction coil wires removed from the screw terminals the induction coil temperature sensor (RTD) connector can be accessed and unplugged from the induction power board. (Fig. 23B)

The RTD connector plug is released by pressing inward on the tab. (Fig. 23C)

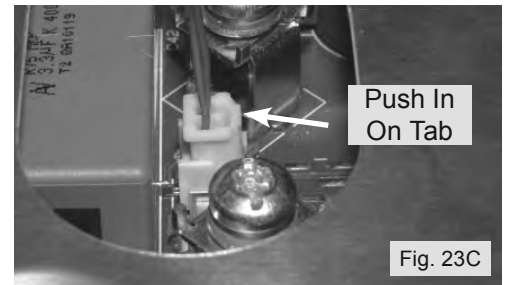
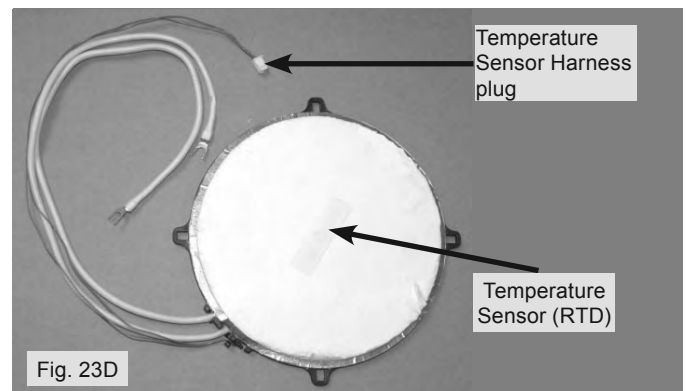

Fig. 23D shows a complete induction coil assembly. To test the coil circuit use an ohm meter to check for continuity between the two forked terminal connectors. The coil should have less than 1 ohm of resistance.

Each induction coil assembly has a temperature sensor (RTD) as part of the assembly. The RTD should measure approximately 1000 ohms of resistance at room temperature. The RTD monitors the surface temperature of the cooking zone and relays this information to the controls. If the surface temperature is above 65°C (149°F) the hot surface indicator “H” will be displayed in the cook zone control display when the cook zone is not in use. If the control detects surface temperatures above 240°C (464°F) it will turn the cooktop off. This is intended to prevent damage to the cooktop and cooking utensils in the event of an empty pan left on the cooktop or if a pan should boil dry. Whenever this shutdown occurs the cook zone control will display “H” . After the surface cools down sufficiently the cooktop can be reactivated in the normal manner.



It should be noted that the individual wires from each induction coil have no polarity and can be connected to either of the screw posts on the power board for that specific cook zone.

Also notice the difference in the wiring configuration of the left side and right side induction coils. On the left side the rear coil connects to the rear set of terminals on the power board but on the right side the rear coil connects to the *front* set of terminals. If the coils are not connected to the proper terminal set the cook zones for that side will not operate and the control will display the flashing “F” when the zone is turned on.

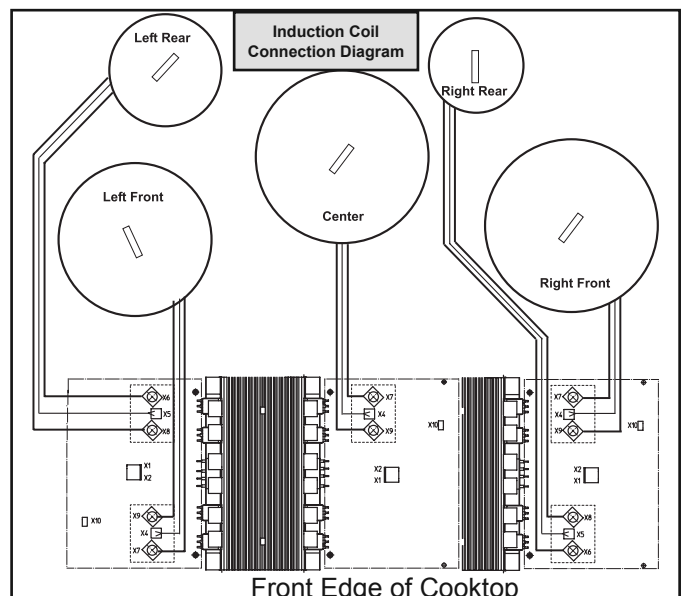

COMPONENT ACCESS AND SERVICE PROCEDURES

Removing The Coil Carrier

The photo in Fig. 24 shows the cooktop coil carrier after the controls, induction coils and insulation pad have been removed. To separate the coil carrier from the induction module housings remove the sixteen screws indicated by the arrows in the photo.

When reinstalling these screws use care not to overtighten and strip the screw receptacle in the induction module housing.

Once the coil carrier panel is removed lift off the insulation board (Fig 24A) that covers the induction modules.



Fig. 24



Fig. 24A

Main Power Components

With the coil carrier panel and insulation board removed the two induction modules and their various power components and surrounding insulation can be accessed (Fig. 24B). The module on the left side controls the left side and center cook zones. The module on the right side controls the two right side cook zones.

From this point either of the induction power generator boards can be removed or replaced as well as the filter boards, cooling fans, heat sink thermal cutouts and connecting wires and cables.

The photo below shows the Filter Boards, Power Boards and Fans as well as the routing of the various connecting cables and wires as they appear when mounted in the housing.

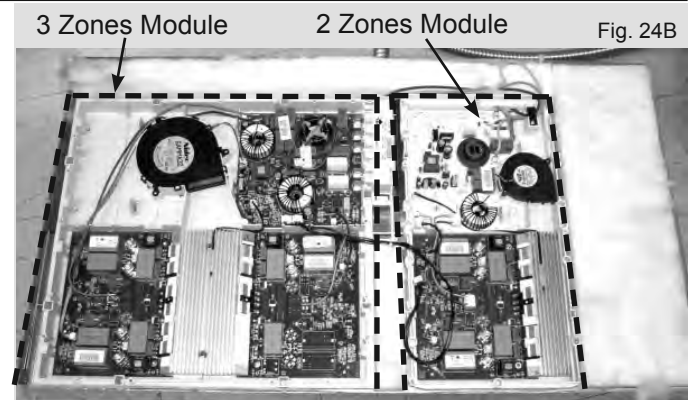
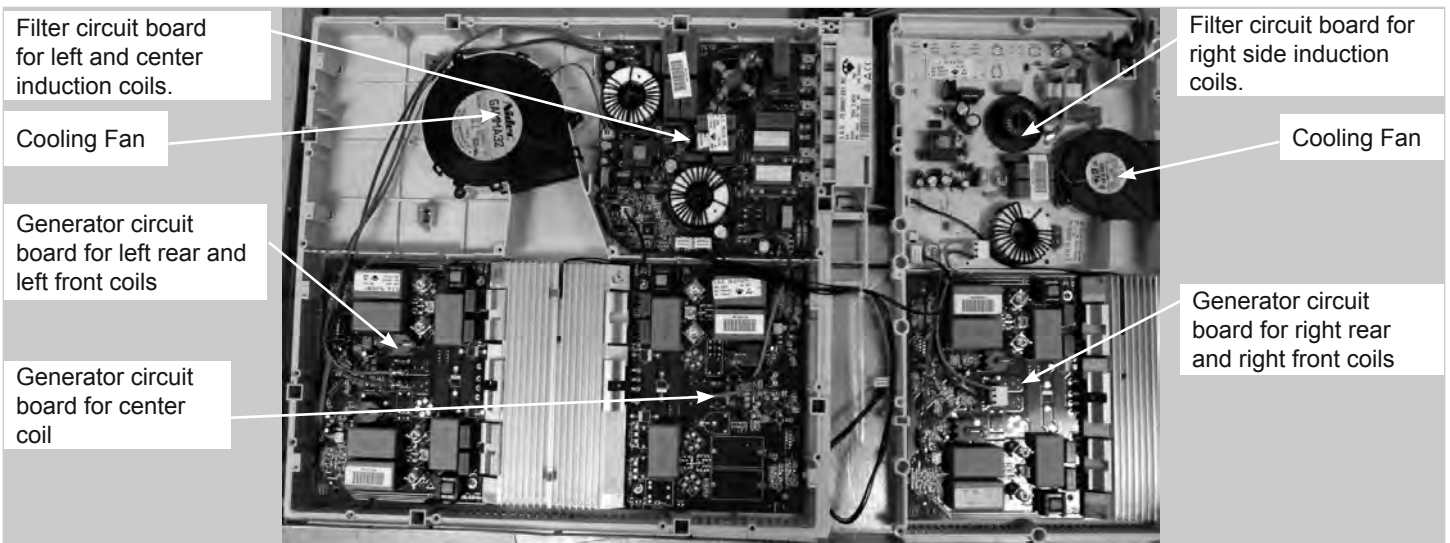

Fig. 24B

NOTE: The illustration below may differ from later production components found in the field.



COMPONENT ACCESS AND SERVICE PROCEDURES

Replacing The Induction Generator Power Board

To remove and replace the power generator boards begin by removing the heat sink thermal cut out. Next remove the two metal clips that clamp the heat sinks together (if present). Gently pry the clip off with a small screwdriver. (Fig. 25)



To unplug the flat cable connector on the filter board and the power generator board (Fig. 25A) use the special cable removal tool.

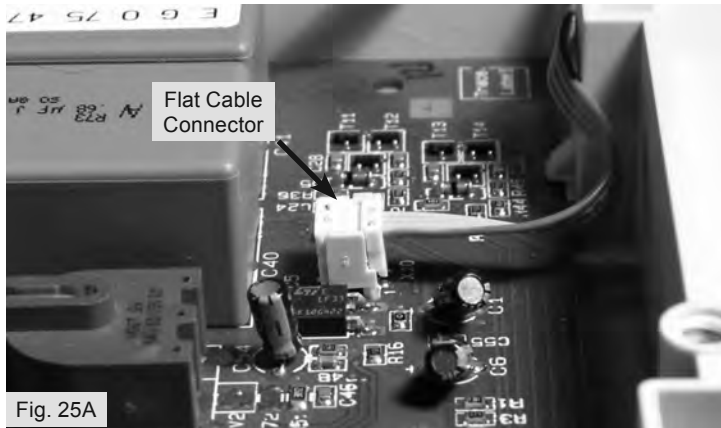

The tool is packaged with each power board and filter board as well as with the replacement cable.

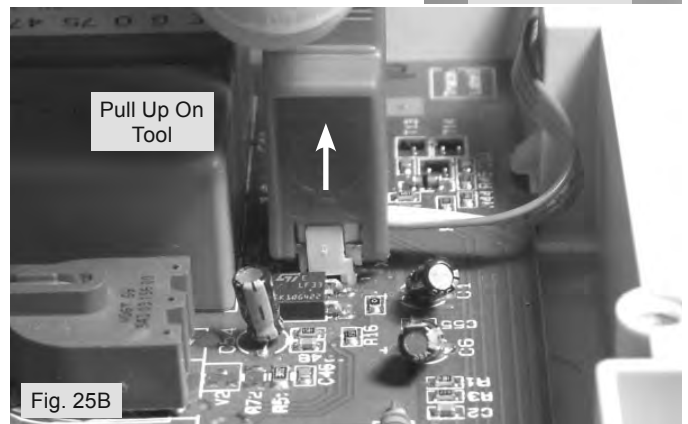

Grip the connector with the tool as shown in the photo and pull up to release the connector (Fig 25B).

Unplug the Blue and Black wires from the power generator board terminals X1 & X2. When reconnecting these wires terminal polarity is not important. Remove the two torx screws that mount the board to the outer case. (Fig. 25C). Lift out the induction power generator board. (Fig. 25D)

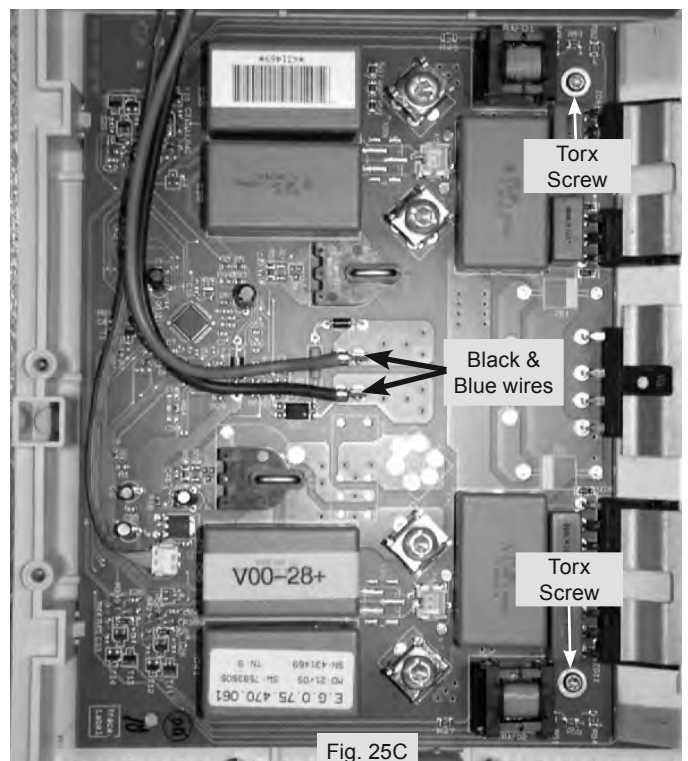

COMPONENT ACCESS AND SERVICE PROCEDURES

Filter Board Replacement (Two Cook Zone Module)

To remove and replace the filter board in the two cook zones module loosen the strain relief retainer screw and remove the black strain relief. Disconnect the L1, L2 & Ground supply wires from the push on terminals (Fig 26).

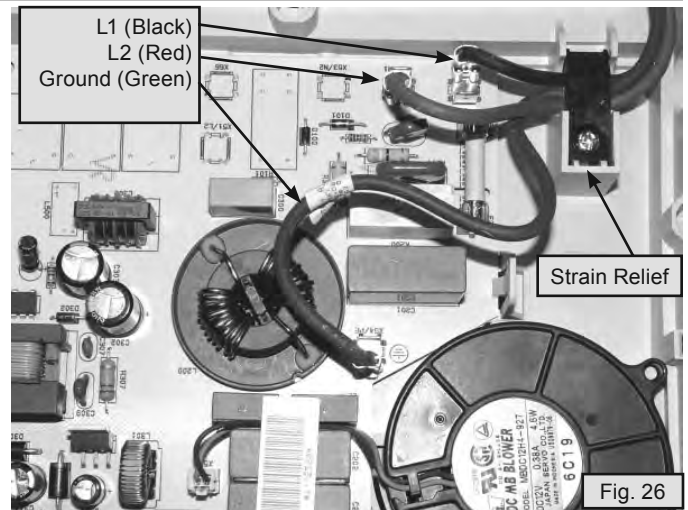

Carefully unplug the remaining wires and connectors. Remember to use the special cable removal tool on the flat ribbon connector at terminal X58 (Fig 26A).

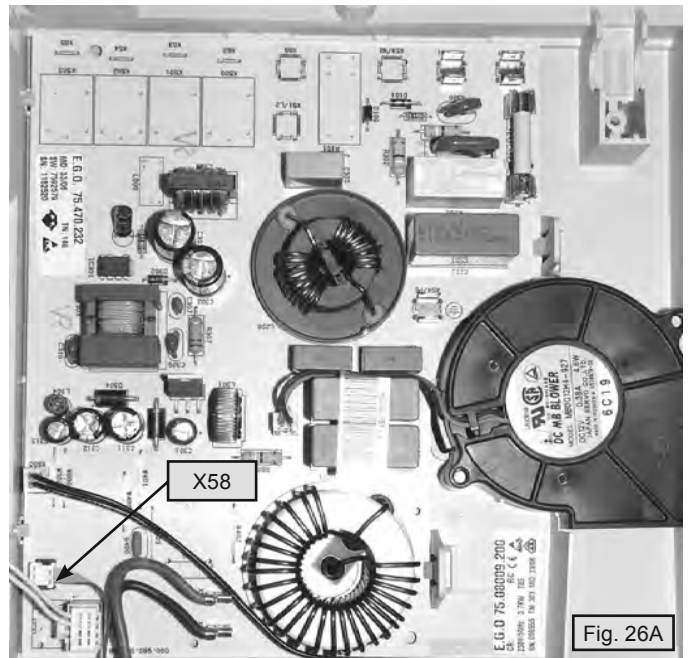

Depress the locking tabs on the right side of the filter board to release the board from the housing (Fig 26B).

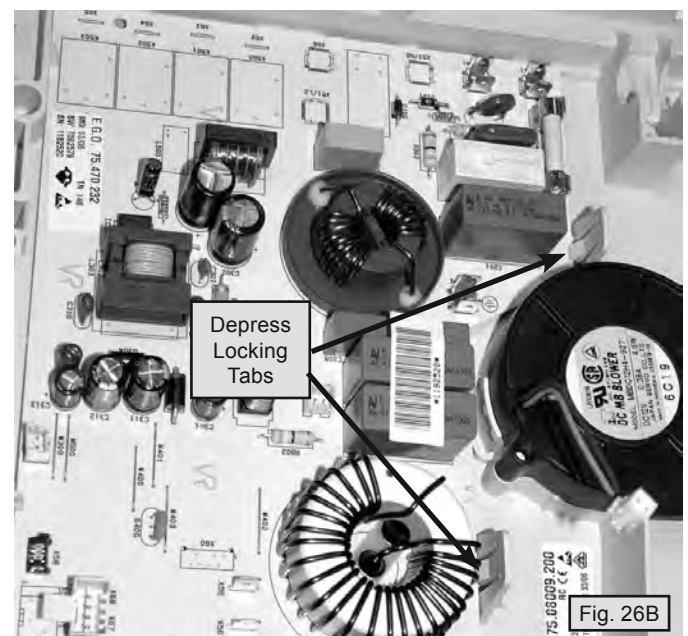

COMPONENT ACCESS AND SERVICE PROCEDURES

Filter Board Replacement (Two Cook Zone Module)

Lift the right side of the filter board high enough to clear the cooling fan and pull in the direction shown to release the opposite side from the housing (Fig 27).

To install the replacement filter board perform the previous steps in reverse order.

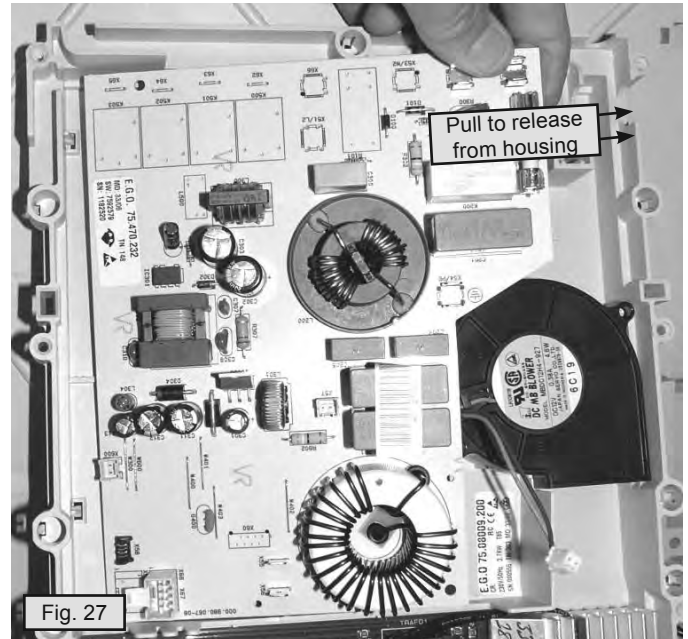

Fig. 27

Filter Board Replacement (Three Cook Zone Module)

To remove and replace the filter board in the three cook zones module it is necessary to disconnect the power cable wires and copper jumpers at the terminal block on the underside of the board. Begin by disconnecting all cables and wires from the board.

Remember to use the special cable removal tool to unplug the ribbon connector at terminal X12 and X13. (Fig 27A)

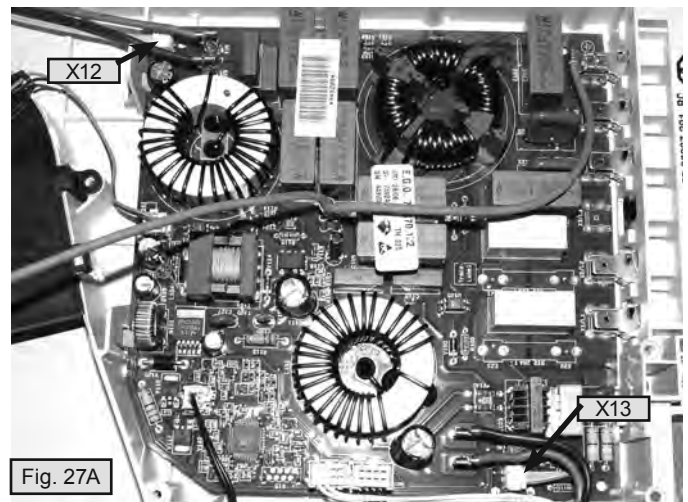

Fig. 27A

Tilt the housing up from the front. The power supply wires and jumpers can be accessed from the underside. (Fig 27B)

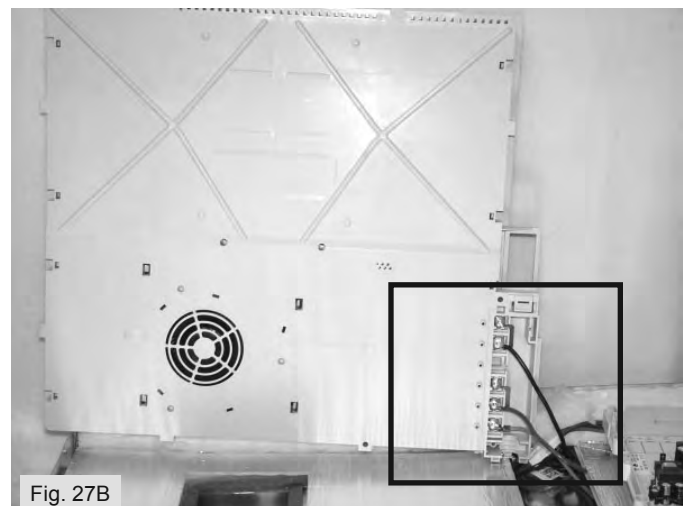
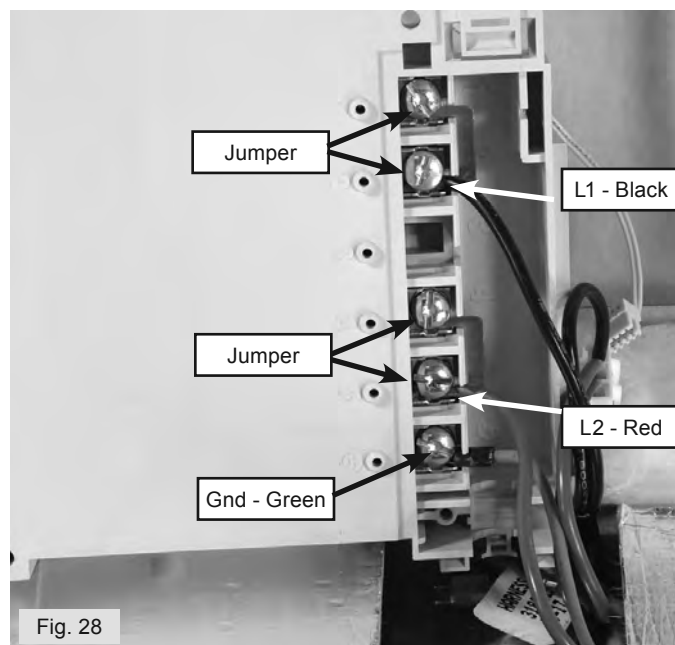

Fig. 27B

COMPONENT ACCESS AND SERVICE PROCEDURES

Filter Board (Three Cook Zone Module)

Disconnect the power supply wires and remove the copper jumpers. Be sure to reinstall the jumpers and wires in the correct terminal locations when reinstalling the filter board. (Fig 28)



Release the locking tabs on the edge of the board near the cooling fan. (Fig. 28A) The filter board can now be removed from the housing.

When reconnecting the wires and cables make sure that the cables go to the correct induction power board. The polarity of the blue and black wires is not important.



TROUBLESHOOTING AND DIAGNOSIS

Whenever a failure or error code is encountered the power supply to the unit should be checked before beginning disassembly. Verify proper voltage and orientation of the power supply wiring connections. Turn off the power supply for thirty seconds and reset it to see if this will clear the error or failure before attempting to replace any parts.

Refer to the installation instructions to ensure that the unit is properly installed. Verify that the unit is being operated in accordance with the instructions found in the owners manual.

TROUBLESHOOTING AND DIAGNOSIS

Error Codes

The electronic components in the induction cooktop have built in error codes to assist in the accurate diagnosis and repair of the unit in the event of failure. The chart found on pages 30 - 32 provides a list of the error code numbers as well as the likely cause and suggested corrective action.

When an error code is displayed the letter “E” will be displayed in the cook zone touch control LEDs (Fig. 8) and the error code number will be displayed in the main touch control timer LED.

See the example at right.



Fig.8



Fig.9

ELECTROLUX ICON 36” INDUCTION COOKTOP ERROR CODES

Error	Possible Cause or Condition	Suggested Corrective Action
2	LF zone control defective key sensor	- Test cables and connections between left side cook zones control and main power control. - Replace left side cook zones touch control
3	LF zone control defective key sensor	
4	LF zone control key sensor defective	
6	LR zone control defective key sensor	
7	LR zone control defective key sensor	
8	LR zone control key sensor defective	
10	Center zone control defective key sensor	- Test cables & connections between center/right rear cook zone control and main power touch control. - Replace center/right rear cook zone control touch control
11	Center zone control defective key sensor	
12	Center zone control key sensor defective	
14	RR zone control defective key sensor	
15	RR zone control defective key sensor	
16	RR zone control key sensor defective	
17	RF zone control key sensor defective	- Test cables & connections on main power/right front cook zone touch control. - Replace main power/right front cook zone touch control
18	RF zone control key sensor defective	
19	RF zone control key sensor defective	
21	Timer key sensor defective	
22	Timer key sensor defective	
23	Keep warm key sensor defective	
24	Lock key sensor defective	
25	Main power key sensor defective	
30 70	AC input voltage too high at the 3 cook zones induction module.	
31	Internal generator error, sync in the 3 cook zones induction module / left side cooking zones.	-Test cables & connections on left side generator circuit board (dual). -Replace the generator circuit board (LF/LR) in the 3 zones induction module

NOTE: If multiple changing error codes are displayed check for disconnected wires or cables.

Induction Cooktop Error Codes continued on next page

ELECTROLUX ICON 36" Induction Cooktop Error Codes

Error	Possible Cause or Condition	Suggested Corrective Action
32 or 72	Low voltage output from 12V supply on filter board in the 3 cook zone induction module.	-Test all cables & connections on filter circuit board in the 3 zones induction module. -Replace the filter circuit board in the 3 zones induction module .
33 or 73	Improper voltage output from filter board in the 3 cook zone induction module.	-Replace generator circuit boards in the 3 zones induction module
34	Communication failure between filter board and power boards in the 3 cook zones induction module / left side cooking zones.	- Check cable between filter board X12 and generator board X10 - Replace the filter circuit board in the 3 zones induction module . - Replace generator circuit board in the 3 zones induction module.
35 or 75	AC input voltage too low in the 3 cook zones induction module.	- Verify AC input voltage at the cooktop input. - Verify AC main input cables, screws and jumpers. - Replace the filter board in the 3 zones induction module
36	Communication error between main touch control and filter board. (3 cook zones induction module / left side cooking zones)	- Verify all communication cables between user interface and both induction generator modules. - Replace the filter circuit board in the 3 zones induction module . - Replace generator circuit board (dual) in the 3 zones induction module .
37	Heat sink temperature sensor break (3 zones induction module / left side cooking zones)	-Replace the generator circuit board (LF/LRI) in the 3 zones induction module
39	Configuration mismatch between the User Interface and the induction module (occurs when one of the 2 zone induction modules is replaced)	- To resolve this error, Press and hold WARM key, then press Right Front zone ON key until beep (keep holding WARM) release Right Front zone ON key and press Left Front zone ON key until beep & config starts. - Replace the filter circuit board in the 3 zones induction module .
40	Communication failure between main touch control and filter board.	- Verify AC input at the (2 zones induction housing) (X50 / X52). - Verify Lin Bus harness cable from X68/X67 on right side filter board (2 zones induction module) to X20 on the left side filter board (3 zones induction module). - Verify the lin communication wire at the timer input at X4/X5 pin 2.
45	Incoming power supply low voltage	- Verify incoming power supply to cooktop
51	LF Element temperature sensor break	- Verify Element temperature sensor is correctly connected to the generator circuit board. - Replace element if temperature sensor resistor value is not approximately 1000 ohms (blue wires) at room temperature. - Replace associated generator circuit board.
52	LR Element temperature sensor break	
53	Center Element temperature sensor break	
54	RR Element temperature sensor break	
55	RF Element temperature sensor break	
60	Touch: general hardware error, keys	- Replace main power touch control. - Replace cook zones touch controls
61	LF Element temperature sensor too hot	- Verify cooktop ventilation is correct (airway and fan). - Verify Element temperature sensor is correctly connect to the generator circuit board. - Replace element if temperature sensor resistor value is not approximately 1000 ohms (blue wires) at room temperature. - Replace associated generator circuit board.
62	LR Element temperature sensor too hot	
63	Center Element temperature sensor too hot	
64	RR Element temperature sensor too hot	
65	RF Element temperature sensor too hot	

NOTE: If multiple changing error codes are displayed check for disconnected wires or cables.

Induction Cooktop Error Codes continued on next page

ELECTROLUX ICON 36" Induction Cooktop Error Codes

Error	Possible Cause or Condition	Suggested Corrective Action
70	See error 30	See error 30
71	Internal generator error, sync (center cooking zone)	<ul style="list-style-type: none"> - Test cables & connections on center generator circuit board (single). - Replace the generator circuit board (single) in the 3 zones induction module .
72	See error 32	See error 32
73	See error 33	See error 33
74	Internal generator error, communication (3 zones induction module)	<ul style="list-style-type: none"> - Check cable between filter board X13 and generator board X10 - Replace the filter circuit board in the 3 zones induction module - Replace generator circuit board in the 3 zones induction module
75	See error 35	See error 35
76	Communication Error in the 3 cook zones induction module for the center cooking zones.	<ul style="list-style-type: none"> - Verify all communication cables between user interface and both induction generator modules. - Replace the filter circuit board in the 3 zones induction module . - Replace generator circuit board for the center cook zone in the 3 zones induction module
77	Heat sink temperature sensor break in the 3 cook zones induction module for the center cooking zones.	<ul style="list-style-type: none"> - Replace generator circuit board for the center cook zone in the 3 zones induction module
80	Flash/Rom check fail (EEPROM data)	<ul style="list-style-type: none"> - Replace main power touch control
90	AC input voltage too high in the 2 cook zones induction module.	<ul style="list-style-type: none"> - Verify AC input voltage at the cooktop input. - Verify AC main input cables, screws and jumpers. - Replace the filter board in the 2 zones induction module
91	Internal generator error, sync in the 2 cook zones induction module.	<ul style="list-style-type: none"> - Test cables & connections on right generator circuit board. - Replace the right side generator circuit board
92	12V on the service section too low in the 2 cook zones induction module.	<ul style="list-style-type: none"> - Test all cables & connections on filter circuit board in the 2 zones induction module.
93	5V overcurrent on the switched 5V on the service section (2 zones induction module).	<ul style="list-style-type: none"> - Replace the filter circuit board in the 2 zones induction module . - Replace generator circuit boards in the 2 zones induction module
94	Internal generator error, communication in the 2 cook zones induction module.	<ul style="list-style-type: none"> - Verify cable between filter board X58 and generator board X10 on the 2 zones induction module. - Verify the heat sink thermal cutout in the 2 zones induction module is connected and resistance is approximately 0 ohms. - Replace the filter circuit board in the 2 zones induction module. - Replace generator circuit board in the 2 zones induction module
95	AC input voltage too low in the 2 cook zones induction module.	<ul style="list-style-type: none"> - Verify AC input voltage at the cooktop input. - Verify AC main input cables, screws and jumpers. - Verify the fuse resistance is approximately 0 ohms in the 2 zones induction module. - Replace the filter circuit board in the 2 zones induction module
96	Communication Error in the 2 cook zones induction module.	<ul style="list-style-type: none"> - Verify all communication cables between user interface and both induction generator module. - Replace the filter circuit board in the 2 zones induction module . - Replace generator circuit board in the 2 zones induction module
97	Heat sink temperature sensor break in the 2 cook zones induction module.	<ul style="list-style-type: none"> - Replace the generator circuit board in the 2 zones induction module

NOTE: If multiple changing error codes are displayed check for disconnected wires or cables.

Additional Failure Conditions

Symptom or Failure	Control Display	Possible Cause or Condition	Suggested Corrective Action
Pan does not heat up.	Normal operation	Pan too small for proper pan detection and only works with low power.	Use larger pan or this pan on a smaller cooking zone. Refer to owners guide for proper pan selection.
	Flashing "F" and pan does not heat.	Pan not detected.	Check whether the pots or pans are suitable for induction. Refer to owners guide for proper pan selection.
		Induction Coil not correctly connected or Induction Coil open.	Check the coil wire terminal connections. Ensure that they are properly connected and tightened. Test continuity of coil (should be less than 1Ω) .
		Distance between coil and glass ceramic too large.	Check whether the coil is properly positioned and touching the glass cooktop surface.
Individual buttons cannot be used or cannot always be used.	None	Touch Control defect.	<ol style="list-style-type: none"> 1. Follow instructions for proper use of touch controls on page 16 2. Check wires and connectors. 3. Replace Touch Control.
Cooking power too low or cooktop shuts down prematurely.	None	Auto Shut Off Activated	Cooktop will automatically shut off after 18 hours of continuous use. Restart cooktop in normal manner.
	None	Fluids spilled or object lying on control panel keypads.	Clean up spills or remove objects. Restart cooktop in normal manner.
	None or " - " Seen in Cook Zone display	Cookzone surface temperature above 240°C (464°F). May be caused by boil dry or empty pan on cook zone.	Remove Pan and allow cook zone to cool.
	Normal operation	Ventilation Slots Obstructed.	Clear vent openings
		Unsuitable pots (bottom bent)	Follow owners guide for proper pan selection
		Distance between coil and glass ceramic too large.	Check whether the glass ceramic was pushed down when being screwed in position and the coil has been correctly positioned.
Fan does not start.		<ol style="list-style-type: none"> 1. Check the fan for foreign objects, remove these where appropriate. 2. If necessary, replace fan. 3 Replace power generator board. 4 Replace Filter Board. 	
No Operation / Dead	No Display . No indicators light when power is applied.	Heat sink thermal cut out open* or unplugged. *If thermal cut out is open check for proper operation of cooling fan and possible vent obstructions.	<ol style="list-style-type: none"> 1. Verify proper incoming power supply. 2. Check connection of heat sink thermal cutout. 3. Test cut out for < 1 Ω resistance. Replace if open.
"H" in display when cooking zone is cold and switched off.	"H"	Temperature sensor defect.	<ol style="list-style-type: none"> 1. Test Coil RTD for approx. 1KΩ at room temperature. Replace coil if resistance is incorrect. 2. Replace power generator board.

COMPONENT PARTS ILLUSTRATION

E36IC75F

CONTROL PANEL

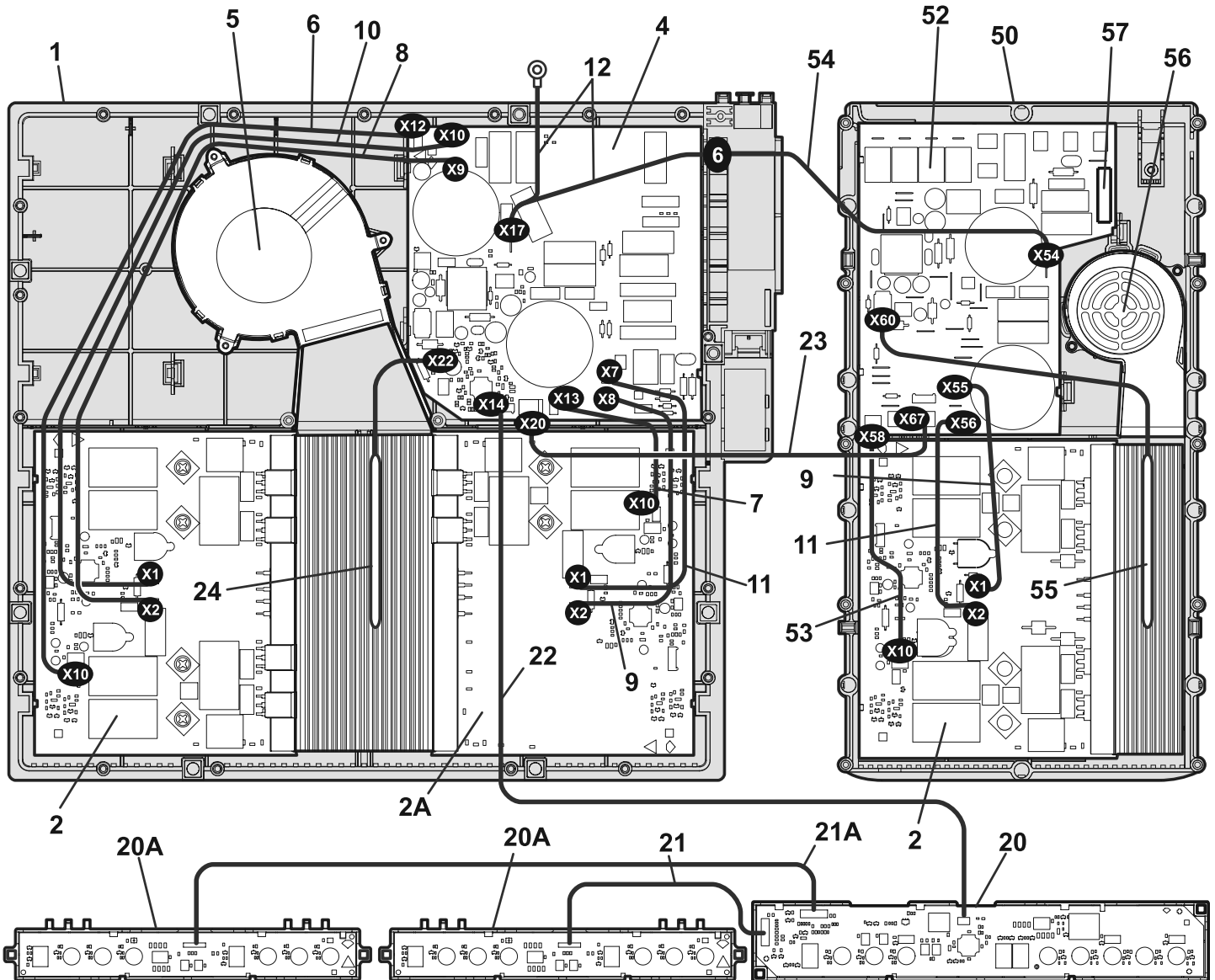

CE36IC75FSS1

COMPONENT PARTS ILLUSTRATION

E36IC75F

POS. NO	DESCRIPTION
1	Housing, plastic carrier, large
2 #	Generator, circuit board, (2), 2 zone
2A #	Generator, circuit board, 1 zone
4 #	Filter, circuit board, large
5 #	Cooling Fan Assembly, large
6 #	Communication Cable, generator, 18", to filter, X10/X12
7 #	Communication Cable, generator, 6", to filter, X10/X13
8 #	Power Cable Set, generator, 18", black, to filter, X2/X9
9 #	Power Cable Set, generator, 6", blue, to filter, (2), X1/X8-X1/X55
10 #	Power Cable Set, generator, 18", blue, to filter, X1/X10
11 #	Power Cable Set, generator, 6", black, to filter, X2/X7-X2/X56
12 #	Ground wire, w/terminal, X17/6-housing
20 #	Touch Control, electronic, center
20A#	Touch Control, cook zone, (2), electronic

POS. NO	DESCRIPTION
21 #	Interface Cable, side control, to center
21A#	Interface Cable, side control, to center
22 #	Communication Cable, center control, to filter
23 #	Communication Cable, filter, to filter, X20/X67
24 #	Thermal Cut-Out, short
50	Housing, plastic carrier, small
52 #	Filter, circuit board, small
53 #	Communication Cable, generator, 8", to filter, X10/X58
54 #	Ground Wire, X54/6
55 #	Thermal Cut-Out, long
56 #	Cooling Fan Assembly, small
57 #	Fuse, fast blow, 20A
* #	Harness, wiring, L1, L2 & ground
*	Frame, display, single, (5)
*	Frame, display, double

* Non illustrated parts

Functional parts

COMPONENT PARTS ILLUSTRATION

E36IC75F

MAIN TOP/SURFACE UNITS

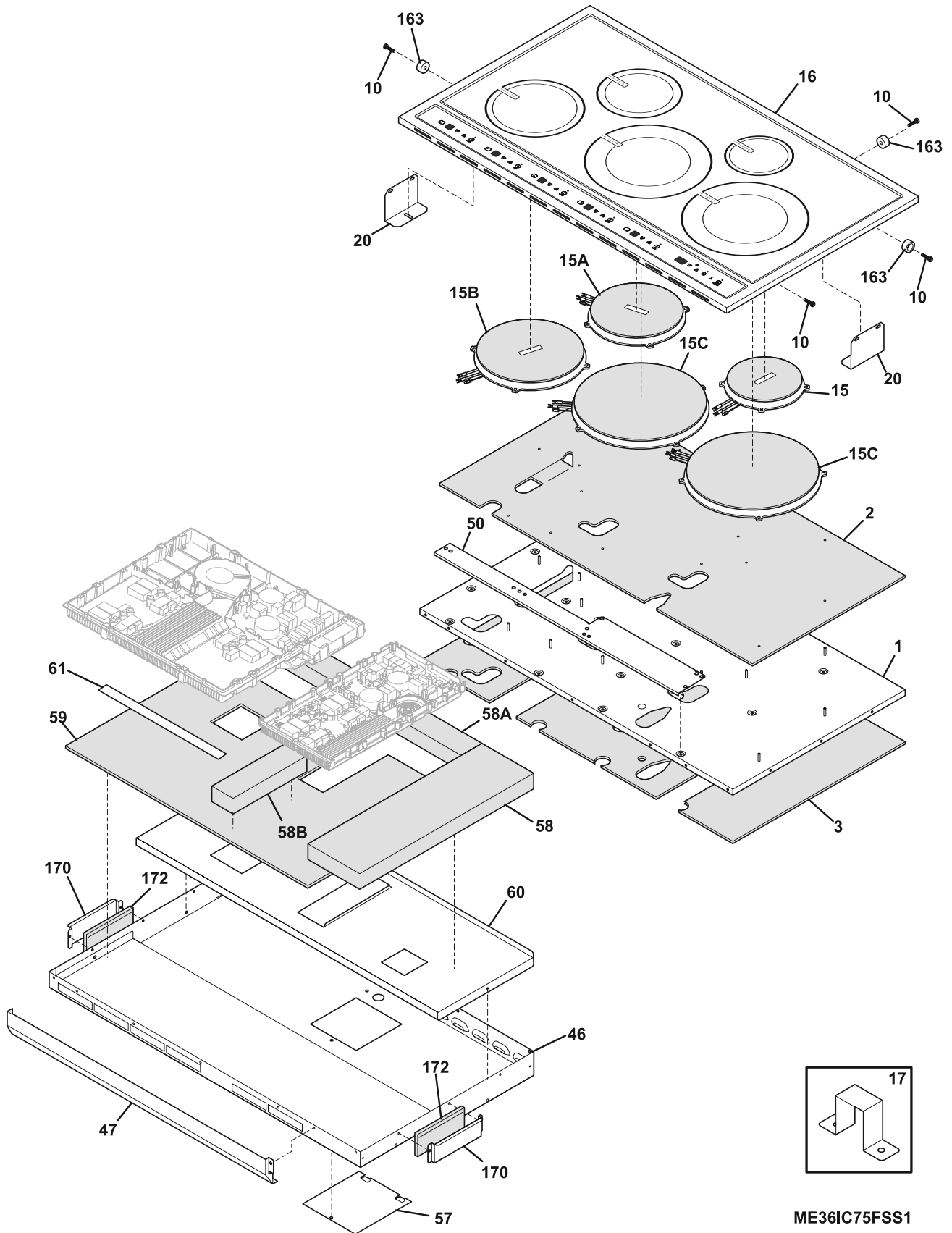

ME36IC75FSS1

COMPONENT PARTS ILLUSTRATION

E36IC75F

POS. NO	DESCRIPTION
1	Panel, CARRIER
2	Insulation, Elements
3	Insulation, carrier panel
10	Screw, 7-19 x 1/2", (11), housing ring
15 #	Element, induction coil, 145MM, right rear
15A#	Element, induction coil, 180MM, left rear
15B#	Element, induction coil, 210MM, left front
15C#	Element, induction coil, 260MM, right front
16	Main Top Assy, glass/steel, black, w/stnless trim
17	Bracket, cable
20	Bracket, retainer
46	Box, burner
47	Deflector, air
50	Panel, spacer

POS. NO	DESCRIPTION
57	Panel, access
58	Insulation, housing, RH
58A	Insulation, housing, rear
58B	Insulation, housing, center
59	Insualtion, housing, lower
60	Deflector, air
61	Foam Tape, 1/2" x 14"
163	Spacer, (6)
170	Screen, thermal, (2)
172	Insulation, screen, (2)
* #	Box & wires assy
*	Clamp, power cord
*	Screw, ground, 10-32 x 0.375
*	Screw, truss head, 8-18 x 0.375
*	Screw, 8 x 0.500
*	Screw, 8-32 x 0.437, (4)

* Non illustrated parts
Functional parts