

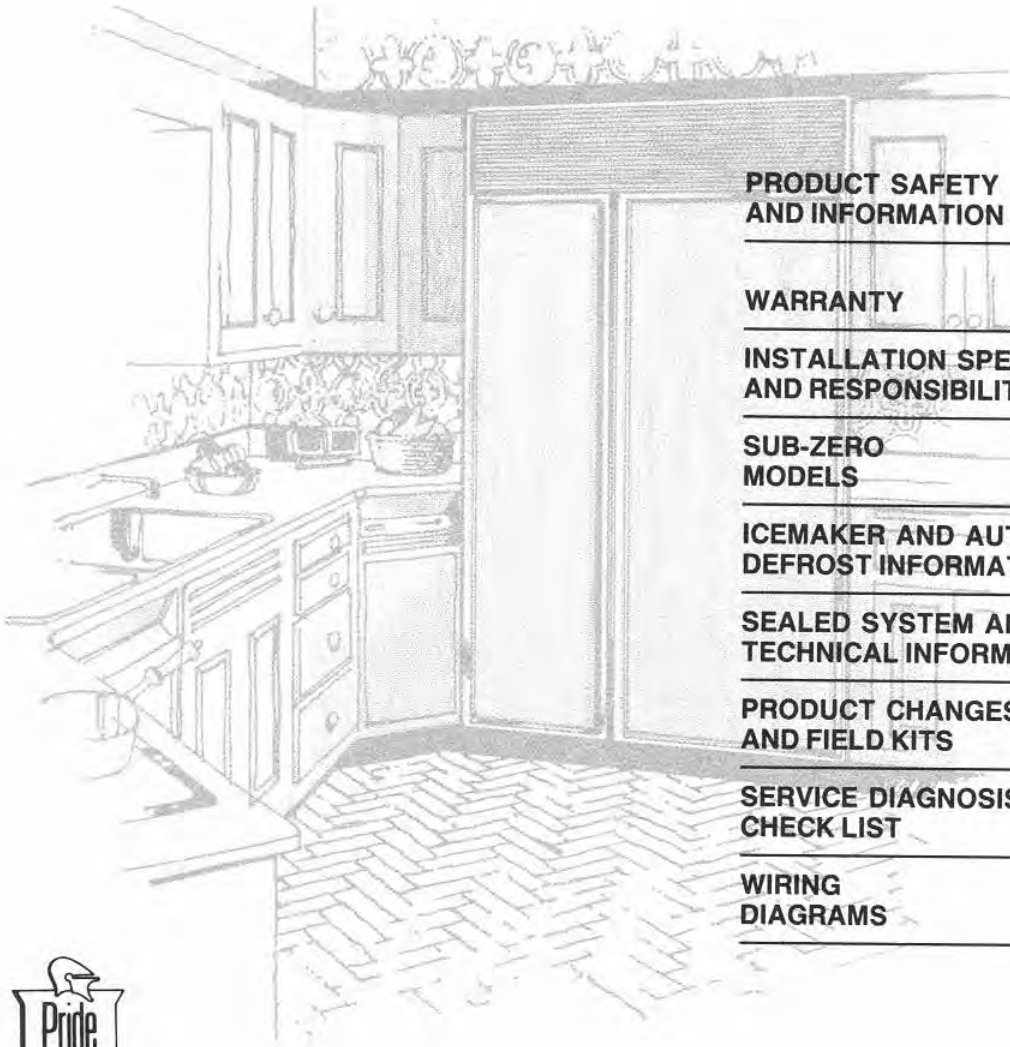

SERVICE MANUAL

200-300 Series



PRODUCT SAFETY AND INFORMATION	1
WARRANTY	2
INSTALLATION SPECIFICATIONS AND RESPONSIBILITIES	3
SUB-ZERO MODELS	4
ICEMAKER AND AUTOMATIC DEFROST INFORMATION	5
SEALED SYSTEM AND TECHNICAL INFORMATION	6
PRODUCT CHANGES AND FIELD KITS	7
SERVICE DIAGNOSIS CHECK LIST	8
WIRING DIAGRAMS	9



NATIONAL ASSOCIATION OF SERVICE MANAGERS

TABLE OF CONTENTS

SECTION		PAGE NUMBER
SECTION 1	PRODUCT SAFETY AND INFORMATION	
SECTION 2	WARRANTY	
	Warranty Clarification.....	2-1
	Starting with Serial #900000.....	2-2
	Between Serial #600000-899999.....	2-3
	Between Serial #202420-599999.....	2-4
	Non-Residential Starting with Serial #830000.....	2-5
SECTION 3	INSTALLATION SPECIFICATIONS AND RESPONSIBILITIES	
	Installation Instructions.....	3-1
	Icemaker & Plumbing.....	3-2
	Electrical.....	3-2
	Panel Installation-Full Size.....	3-3
	-Undercounter.....	3-3
	Hinge Adjustments-Full Size.....	3-4
	-Undercounter.....	3-4
	Swing Change.....	3-4
	Product Specifications.....	3-5
SECTION 4	MODEL SPECIFICATIONS	
	Production Date and Serial Number Correlation.....	4-1
	Chambers to Sub-Zero Cross Reference.....	4-1
SECTION 5	ICEMAKER & AUTOMATIC DEFROST INFORMATION	
	Automatic Defrost Specifications.....	5-1
	Test Cycling the Modular Icemaker.....	5-1
	Modular Icemaker Breakdown.....	5-2
	Trouble Diagnosis for Modular Icemaker.....	5-3
	Test Cycling the Compact Icemaker.....	5-3
	Complete Icemaker Breakdown (4-20-031-0).....	5-4
	Compact Icemaker Breakdown (3-14-001-0).....	5-5
	Compact Icemaker Breakdown (3-14-007-0).....	5-6
	Trouble Diagnosis for Compact Icemaker.....	5-7

SECTION 6	SEALED SYSTEM & TECHNICAL INFORMATION	PAGE NUMBER
	Control Data.....	6-1
	Air Flow.....	6-2
	Serial Number Breaks for Reference Sheets.....	6-3
	System Charges and Pressures by Model Number for Serial Number Groups.....	6-3
	Compressor Data.....	6-4
	System Diagnosis and Procedures.....	6-5
	System Diagnosis Checklist.....	6-5
	System Leak Detection Procedures.....	6-6
	Defective Compressor Diagnosis.....	6-7
	Condensate Loop Leak Repair.....	6-8
SECTION 7	PRODUCT CHANGES AND FIELD KITS	
	Quick Reference on Product Changes from 1976-1985....	7-1
	22IM Serial #272342-509240.....	7-2
	22IM Redesign.....	7-3
	Door Stop Kit.....	7-4
	Door Closer for Model 201.....	7-4
	201 Field Door Closer Kit.....	7-4
	Undercounter Door Closer Kit.....	7-4
	Undercounter Door Swing Change Kit.....	7-4
	2011ICE Door Assembly.....	7-5
	Ice/Icicle Formation in Freezer Door.....	7-5
	Sweating Around Freezer Door.....	7-5
	Crispers Falling off Tracks.....	7-6
	Water in Bottom of Refrigerator Section.....	7-6
	Ice Formation.....	7-6
	Shelf Bar Clip.....	7-6
	Wine Storage Control for Model 201R & 249RP.....	7-6
	Step Down Transformer.....	7-6
	Hard Start/Low Voltage Capacitor Kit.....	7-7
	Compressor Vibration/Shuttering at Shut-off.....	7-7
	Refrigerator Evaporator/Heat Exchanger Kit.....	7-7
	Condenser Fan Operation.....	7-8
	Supplemental Heater Kits.....	7-8
	Freezer Frame/Drain Heater Kits.....	7-8
	Light Switch Kit.....	7-9
	Surrounding Ambient Temperatures.....	7-9
	Shutting Equipment Down.....	7-9
	Paint Scratches-Repairing & Touch-up.....	7-10
SECTION 8	SERVICE DIAGNOSIS CHECK LIST	

SECTION 9 WIRING DIAGRAMS

PAGE NUMBER

361RFD	Starting with Serial #M393833/P397233...	9-1
	Between Serial #227972-M397233.....	9-2
	Prior to Serial #227972.....	9-3
3211RFD	Starting with Serial #M393833/P397233...	9-4
	Between Serial #227972-M393733/P397233..	9-5
	Prior to Serial #227972.....	9-6
211RFD	Starting with Serial #M393733/P397233...	9-7
	Between Serial #227972-M393733/P397233..	9-8
	Prior to Serial #227972.....	9-9
241RFD	Starting with Serial #M393733/P397233...	9-7
	Between Serial #227972-M393733/P397233..	9-8
	Prior to Serial #227972.....	9-9
251RFD	Starting with Serial #M393733/P397233...	9-7
	Between Serial #227972-M393733/P397233..	9-8
	Prior to Serial #227972.....	9-9
2711RFD	Starting with Serial #455971.....	9-10
	Between Serial #393733/P397233-455970...	9-11
	Between Serial #M368247-M393733/P397233.	9-12
2811	Starting with Serial #455971.....	9-10
	Starting with Serial #P583741.....	9-13
2411	Between Serial #227972-M393733/P397233..	9-15
	Prior to Serial #227972.....	9-16
2511	Between Serial #227972-M393733/P397233..	9-15
	Between Serial #M393733/P397233-M464688.	9-14
	Prior to Serial #227972.....	9-16
201R	Starting with Serial #227972.....	9-17
	Prior to Serial #227972.....	9-18
215R	Starting with Serial #227972.....	9-17
201FD	Starting with Serial #227972.....	9-19
	Prior to Serial #227972.....	9-20
2011ICE	Starting with Serial #393403.....	9-21
201RIM	Between Serial #273392-360121.....	9-22
249R/RP	Starting with Serial #227972.....	9-23
249FF	Starting with Serial #662466.....	9-24
	Between Serial #227972-662466.....	9-25
244RFD	Between Serial #227972-662466.....	9-25
245RFD	Starting with Serial #662066.....	9-26
	Between Serial #464681-662066.....	9-27
801RFD	Starting with Serial #659116.....	9-28
	Between Serial #227972-659116.....	9-29
22IM	Starting with Serial #509241.....	9-30
	Between Serial #271942-509240.....	9-31

M-Prefix Before Serial No.
Madison Equipment
P-Prefix Before Serial No.
Phoenix Equipment

SECTION 1
PRODUCT SAFETY
AND INFORMATION

PRODUCT
SAFETY
AND
INFORMATION





PRODUCT SAFETY INFORMATION

LISTED BELOW ARE THE PRODUCT SAFETY WARNING LABELS. WHEN REVIEWING THIS MANUAL, PLEASE NOTE THESE DIFFERENT LABELS PLACED IN AREAS WHERE PERSONAL AWARENESS OF PRODUCT SAFETY SHOULD BE TAKEN.

IN THIS SERVICE MANUAL, THERE WILL BE 'SIGNAL WORDS' PLACED IN THE APPROPRIATE AREAS. THIS WILL INDICATE WHEN PROPER SAFETY PRECAUTIONS ARE TO BE FOLLOWED.

THE 'SIGNAL WORDS' USED IN THIS MANUAL WILL EITHER BE **WARNING** OR **CAUTION**. SEE BELOW FOR BOTH THE SIGN ITSELF AS WELL AS THE DESCRIPTION AND AREAS OF PRECAUTION.



WARNING: HAZARDS OR UNSAFE PRACTICES WHICH COULD RESULT IN SEVERE PERSONAL INJURY OR DEATH
(see examples below).

1. Defrost heaters, compressors and condenser fan motors are hot.
2. System Pressures - do NOT overcharge.
3. Flames from a welding torch.
4. Shut off electrical power when attempting repairs.

CAUTION: HAZARDS OR UNSAFE PRACTICES WHICH COULD RESULT IN MINOR PERSONAL INJURY OR PRODUCT AND/OR PROPERTY DAMAGE (see examples below).

1. Sharp objects; evaporator and condenser fins.
2. Lifting heavy objects; door/drawer assemblies, compressors.
3. Condenser and evaporator coil fins are easy to bend.

REMEMBER: WHEN SERVICING A SUB-ZERO PRODUCT, SAFETY IS ALWAYS FIRST

M-Prefix Before Serial No.
Madison Equipment
P-Prefix Before Serial No.
Phoenix Equipment

SECTION 2 **WARRANTY**

WARRANTY



WARRANTY CLARIFICATION

With the passage of the years, there have been many changes in warranty length. Hopefully, the following will clarify any questions you may have regarding the ever-changing warranty status:

M-Prefix Before Serial Number = Madison Equipment
P-Prefix Before Serial Number = Phoenix Equipment

Serial Numbers 202420 through 599999
(May 15, 1976 - December 31, 1986)

One year TOTAL product warranty, parts and labor
Five year SEALED SYSTEM warranty, parts and labor

Serial Numbers 600000 through 900000
(or installed after January 1, 1987)

One Year TOTAL product warranty, parts and labor
Three Year MECHANICAL warranty, parts only
Five Year SEALED SYSTEM warranty, parts and labor
Sixth through Twelfth Year LIMITED PARTS warranty, sealed system parts only

Starting with serial number 900000
(April 15, 1991)

Two Year TOTAL product warranty, parts and labor
Five Year SEALED SYSTEM warranty, parts and labor
Sixth through Twelfth Year LIMITED PARTS warranty, sealed system parts only

Any unit installed non-residentially, beginning with serial number **830000** (January 1, 1990) is covered by a One Year TOTAL product warranty **ONLY**.

Since the inception of our new extended warranty, some questions have arisen regarding the specific coverage. Indicated below is a brief listing for your reference of what should be covered under the second and third year of coverage.

All Controls, Evaporator Fan Motors & Blades, Switches	
Condenser Fan Motor & Blade	Frozen Inlet Tubes (only 1)
Defrost Heaters, Terminators, Timer	Inlet Water Fitting Assembly
Door Closer Cam & Spring Types	Compressor Relays & Overloads
Drain Tube Heater, Hose, Pan	Door Hinges (broken or bent)
Icemaker & Water Valve	Light Sockets

SUB-ZERO

“PROTECTION PLAN”

**Full 5 Year Warranty and Limited 6th through
12th Year Warranty on the Sealed System
Full 2 Year Warranty on the Total Product**

FULL FIVE YEAR WARRANTY

For five years from the date of original installation, your Sub-Zero warranty covers all parts and labor to repair or replace any components that prove to be defective in materials or workmanship in the sealed system. The sealed system consists of the compressor, condenser, evaporator, drier and all connecting tubing.

FULL TWO YEAR WARRANTY

For two years from the date of original installation, your Sub-Zero warranty covers all parts and labor to repair or replace any part of the product which proves to be defective in materials or workmanship.

LIMITED 6TH THROUGH 12TH YEAR WARRANTY

From the 6th through 12th year from the date of original installation, your Sub-Zero warranty covers all parts that prove to be defective in materials or workmanship in the sealed system (parts only). The sealed system consists of the compressor, condenser, evaporator, drier and all connecting tubing.

TERMS APPLICABLE TO EACH WARRANTY

All service provided by Sub-Zero under the above warranty must be performed by authorized Sub-Zero service representatives, unless otherwise specified by Sub-Zero. Service will be provided in the home during normal business hours. This warranty applies only to products installed for normal residential use. Details regarding a non-residential warranty are available upon request.

The warranty applies only to products installed in any one of the fifty states of the United States, the District of Columbia or the ten provinces of Canada. This warranty does not cover any parts or labor to correct any defect caused by negligence, accident or improper use, maintenance, installation, service or repair, including but not limited to improper removal and reinstallation (whether in the unit or at a remote location) of the condensing unit.

THE REMEDIES DESCRIBED ABOVE FOR EACH WARRANTY ARE THE ONLY ONES WHICH SUB-ZERO WILL PROVIDE, EITHER UNDER THESE WARRANTIES OR UNDER ANY WARRANTY ARISING BY OPERATION OF LAW. SUB-ZERO WILL NOT BE RESPONSIBLE FOR ANY CONSEQUENTIAL OR INCIDENTAL DAMAGES ARISING FROM THE BREACH OF THESE WARRANTIES OR ANY OTHER WARRANTIES, WHETHER EXPRESS, IMPLIED OR STATUTORY.

Some states do not allow the exclusion or limitation of incidental or consequential damages, so the above limitation or exclusion may not apply to you. This warranty gives you specific legal rights and you may also have other legal rights which vary from state to state.

To receive parts and/or service and the name of the Sub-Zero authorized service representative nearest you, contact your Sub-Zero dealer or distributor or contact the Sub-Zero Freezer Company, Service Department, P.O. Box 44130, Madison, Wisconsin, 53744-4130 or call (800) 356-5826.

SERIAL NUMBERS 600000 THROUGH 899999



SUB-ZERO

PRODUCT WARRANTY

There has been some confusion in the field in determining if a unit is still under warranty, specifically with regard to the three year mechanical warranty. **Please make a note that any Sub-Zero unit installed after January 1, 1987 and/or after Serial #600000 carries the warranty indicated below:**

- A. **FULL ONE YEAR WARRANTY** - For one year from the date of original installation, our Sub-Zero Warranty covers all parts and labor to repair or replace any part of the product which proves to be defective in materials or workmanship.
- B. **FULL THREE YEAR MECHANICAL WARRANTY*** - For three years from the date of original installation, our Sub-Zero Warranty covers **all parts and labor** to repair or replace any mechanical component(s) that prove to be defective in materials or workmanship (i.e.: timer, motors, switches, controls, icemakers).
- C. **FULL FIVE YEAR SEALED SYSTEM WARRANTY** - For five years from the date of original installation, our Sub-Zero Warranty covers **all parts and labor** to repair or replace any component that proves to be defective in materials or workmanship in the sealed system. The sealed system consists of the compressor, condenser, evaporator, dryer, and all connecting tubing.
- D. **LIMITED 6th THROUGH 12th YEAR SEALED SYSTEM WARRANTY** - From the 6th through the 12th year from the date of the original installation, our Sub-Zero Warranty covers **all parts** that prove to be defective in materials or workmanship in the sealed system (parts only). The sealed system consists of the compressor, condenser, evaporator, dryer, and all connecting tubing.

**Since the inception of our new extended warranty, some questions have arisen regarding the specific coverage. Indicated below is a brief listing for your reference of what should be covered under the second and third year of coverage.*

Second and Third Year Warranty:

All Controls	Drain Hose
All Evaporator Fan Motors and Blades	Drain Pan
All Switches	Icemaker Water Valve
Condenser Fan Motor and Blade	Icemaker
Defrost Heaters	Inlet Water Fitting Assembly
Defrost Terminators	Frozen Inlet Tubes (only one)
Defrost Timer	Light Sockets
Door Closer Cam and Spring Type	Relay and Overloads, Compressor
Drain Tube Heater	Door Hinges (broken or bent)

NOTE: If there are any questions with reference to our warranties, please contact either our Customer Relations Department (1-800-356-5826) or our Warranty Claims Department (1-800-225-2459) for further assistance.

SERIAL NUMBER 202420 THROUGH 599999

SUB-ZERO

PRODUCT WARRANTY

**FULL FIVE YEAR WARRANTY
ON SEALED SYSTEM
FULL ONE YEAR WARRANTY
TOTAL PRODUCT**

For five years, from the date of original installation, your Sub-Zero warranty covers all parts and labor to repair or replace any sealed system components that prove to be defective in materials or workmanship. The sealed system consists of the compressor, condenser, evaporator, drier and all connecting tubing.

For one year, from the date of original installation, your Sub-Zero warranty covers all parts and labor to repair or replace any part of the entire unit which proves to be defective in materials or workmanship.

All service provided by Sub-Zero under the above warranty must be performed by authorized Sub-Zero service representatives. Service will be provided in the home during the normal business hours after you notify us of the need for service during the warranty period.

The warranty applies only to products installed in the United States and Canada. This warranty does not cover any parts or labor to correct any defect caused by negligence, accident or improper use, maintenance, installation, service or repair, including but not limited to improper removal and reinstallation (whether in the unit or at a remote location) of the condensing unit, occurring after sale.

This remedy of repair or replacement provided for herein is exclusive as to this warranty and as to any warranty that may arise by operation of law. Sub-Zero shall not be responsible for any consequential or incidental damages arising from the breach of this or any other warranty, whether expressed, implied or statutory.

Some states do not allow the exclusion or limitation of incidental or consequential damages, so the above limitation or exclusion may not apply to you. This warranty gives you specific legal rights and you may also have other legal rights which vary from state to state.

For the name of the Sub-Zero authorized representative nearest you, contact your Sub-Zero dealer, distributor or contact Sub-Zero Freezer Company, Customer Relations Department, P. O. Box 4130, Madison, Wisconsin 53711-0130 or call:

Wisconsin, Hawaii, Alaska & Canada residents (608) 271-2233
Other residents (800) 356-5826

BEGINNING WITH SERIAL 830000



SUB-ZERO

“NON-RESIDENTIAL WARRANTY”

Full 1 Year Warranty on the Total Product

FULL ONE YEAR WARRANTY

For one year from the date of original installation, your Sub-Zero warranty covers all parts and labor to repair or replace any part of the product which proves to be defective in materials or workmanship.

TERMS APPLICABLE TO EACH WARRANTY

All service provided by Sub-Zero under the above warranty must be performed by authorized Sub-Zero service representatives, unless otherwise specified by Sub-Zero.

The warranty applies only to products installed in any one of the fifty states of the United States, the District of Columbia or the ten provinces of Canada. This warranty does not cover any parts or labor to correct any defect caused by negligence, accident or improper use, maintenance, installation, service or repair, including but not limited to improper removal and reinstallation (whether in the unit or at a remote location) of the condensing unit.

THE REMEDIES DESCRIBED ABOVE FOR THIS WARRANTY ARE THE ONLY ONES WHICH SUB-ZERO WILL PROVIDE, EITHER UNDER THIS WARRANTY OR UNDER ANY WARRANTY ARISING BY OPERATION OF LAW. SUB-ZERO WILL NOT BE RESPONSIBLE FOR ANY CONSEQUENTIAL OR INCIDENTAL DAMAGES ARISING FROM THE BREACH OF THIS WARRANTY OR ANY OTHER WARRANTY, WHETHER EXPRESS, IMPLIED OR STATUTORY.

Some states do not allow the exclusion or limitation of incidental or consequential damages, so the above limitation or exclusion may not apply to you. This warranty gives you specific legal rights and you may also have other legal rights which vary from state to state.

To receive parts and/or service and the name of the Sub-Zero authorized service representative nearest you, contact your Sub-Zero dealer or distributor or contact the Sub-Zero Freezer Company, Service Department, P.O. Box 44130, Madison, Wisconsin, 53744-4130 or call (800) 356-5826.

M-Prefix Before Serial No.
Madison Equipment
P-Prefix Before Serial No.
Phoenix Equipment

SECTION 3
INSTALLATION SPECIFICATIONS
AND RESPONSIBILITIES

INSTALLATION
SPECIFICATIONS
AND
RESPONSIBILITIES

SUB-ZERO

STEP 1 After uncrating unit, remove wood base and discard the shipping bolts (except undercounter models—shipping bolts are the leveling legs) which secured the wood base to bottom of unit.

STEP 2 Remove all packaging materials and tape.

STEP 3 Loosen electrical cord. To achieve this on all combination models, remove grille by cutting nylon shipping strap and removing center grille screw. Refer to Fig. 1. On all other models, the cord is simply located on rear of unit.

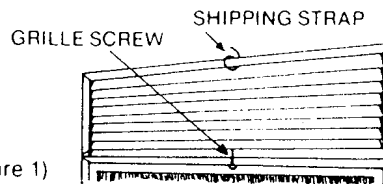

(Figure 1)

STEP 4 For units with automatic icemaker, refer to detail Fig. A ICEMAKER & PLUMBING.

STEP 5 **▲WARNING** To prevent unit from tipping forward under certain load conditions and insure a stable installation we recommend installing a block to the back wall as illustrated. We also recommend the floor under the refrigerator be at the same level as the surrounding floor.

(Figure 2)

Blocking not required if units fit under soffit with clearance between top of unit and soffit of 1" or less.

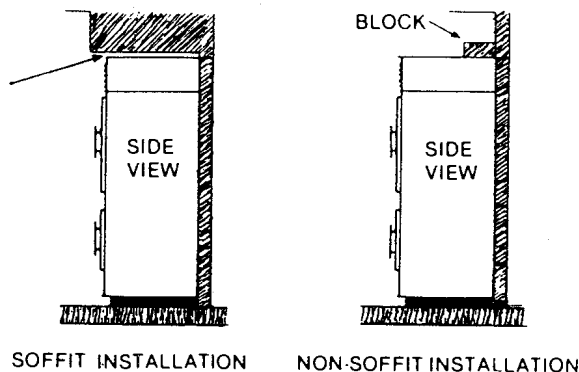

STEP 6 Plug into 15 amp grounded outlet, refer to detail Fig. B ELECTRICAL for electrical requirements. Slide unit into desired position. Refer to Fig. E, SCHEMATIC DRAWING for rough opening dimensions.

STEP 7 Level unit: To raise, turn levelers clockwise—to lower, turn levelers counter-clockwise using an adjustable wrench or pliers. A leveling tool is provided for the rear levelers. (leveling tool not required for undercounter models. Refer to diagram (Fig. 3).

(Figure 3)

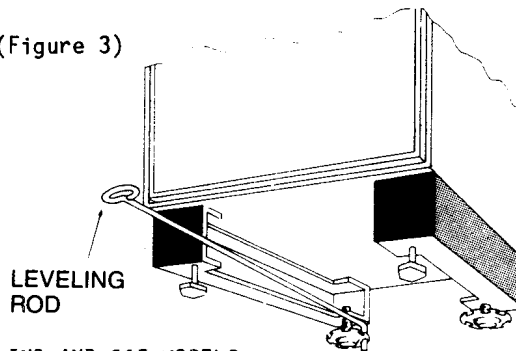

ALL BUILT-INS AND 215 MODELS

STEP 8 Install Toe Plate.

See diagram (Fig. 4).

CAUTION: Do not block toe plate louvers with carpeting, baseboard or other materials.

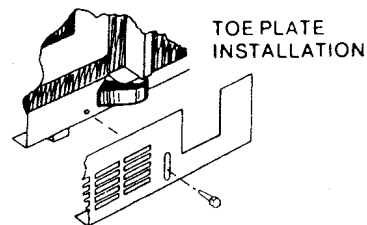

(Figure 4)

STEP 9 IMPORTANT: Replace center grille screw removed in step "3".

STEP 10 Apply decorative front panels (and side panels, if applicable). Refer to detail Fig. C PANEL INSTALLATION.

STEP 11 It is possible that doors may become out of adjustment in shipment. If doors need readjustment, please refer to detail Fig. D HINGE ADJUSTMENT. IMPORTANT: For proper operation and use, the door must open a full 90 degrees. A 2" filler should be used in corner installations to assure a 90 degree door opening. Remember to allow enough clearance in front of unit for full door swing. IMPORTANT: Minimum 1" filler recommended when 201 models installed hinge to hinge.

Figure A. ICEMAKER & PLUMBING

The icemaker in your Sub-Zero is fully automatic and has been factory pre-tested. To put into operation, it requires only a connection to the house water supply. Typical installation:

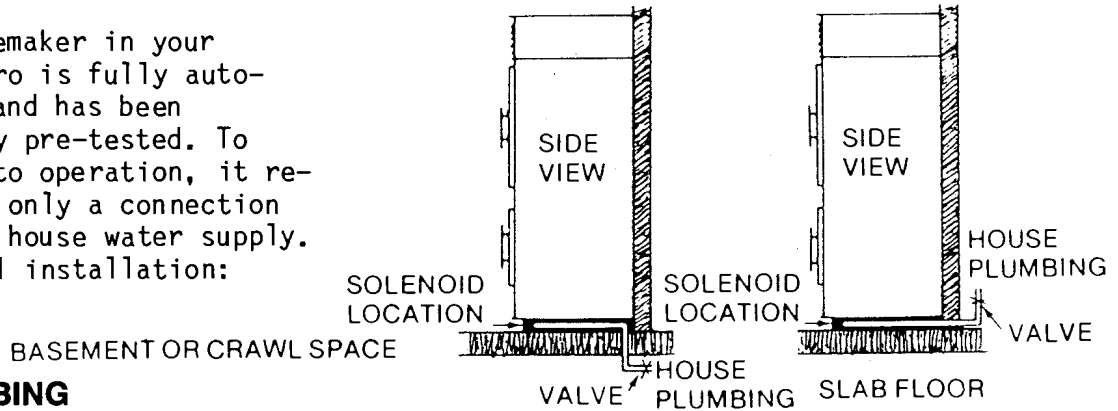

PLUMBING

Connect a 1/4" copper line to the house supply, being sure to use a valve between the supply and your refrigerator.

Note: Do not use a "self-piercing" valve.

Icemaker operates on water pressure of 20 to 100 PSI. Coil four feet of copper line for connection to the refrigerator. (Refer to Fig. E) Slip solenoid valve compression nut on copper tubing as shown in diagram and tighten. Turn on water supply valve and check fitting to solenoid. Note: A line filter is recommended when water conditions have a high mineral content.

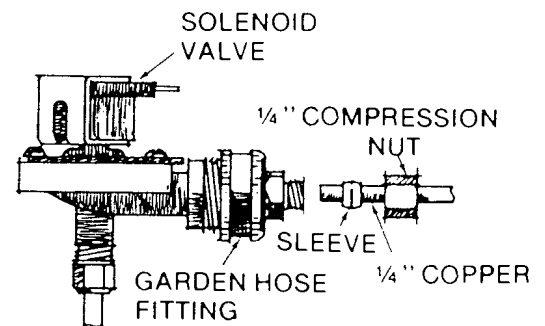
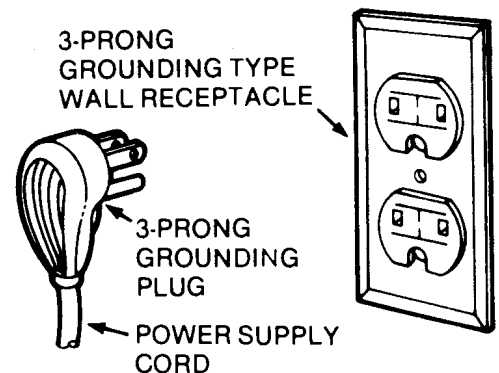

Figure B. ELECTRICAL

A 115 volt, 60 Hz, 15 amp fused electrical supply is required (time delay fuse or circuit breaker is recommended.) It is recommended that a separate circuit, serving only this appliance, be provided. DO NOT use an extension cord.

ELECTRICAL GROUND IS REQUIRED ON THIS APPLIANCE.

This appliance is factory equipped with a power supply cord with a 3-prong grounding plug. It must be plugged into a mating 3-prong grounding type wall receptacle grounded in accordance with the National Electrical Code and local codes and ordinances.



⚠ WARNING

DO NOT UNDER ANY CIRCUMSTANCES, REMOVE THE POWER SUPPLY CORD GROUND PRONG.

Figure C. PANEL INSTALLATION - FULL SIZE

All Sub-Zero units are manufactured in a manner to achieve a total built-in appearance (except free-standing models 215R and 215FD). This allows you to choose the decorative material and color application for the front and sides (if exposed) for your refrigerator/freezer. To install front panel on all Sub-Zero built-in and undercounter models:

- 1) With "small tipped" Phillips screwdriver, remove door handle. NOTE: on models 361RFD, 3211RFD, 2711 Freezer door and all undercounter models, the door handle also acts as trim molding.
 - 2) Slide panel into frame on door (if snug fit, you may loosen screws in top and bottom of panel frame). If a metal or other thin material is applied, we recommend two .100 thick chipboard fillers be inserted behind your panel to insure a proper fit. All frames are designed to accept up to 1/4" material. If a raised, wood panel is being used, the edges must, of course, be routed to the necessary 1/4" border specifications.
 - 3) With panel in position, replace frame molding and handle. Replace and tighten all screws. Special care should be taken not to overtighten and "strip" screws. Please refer to Figure E SCHEMATIC DRAWING for front panel dimensions. If side panels are being utilized, please refer to detailed side panel installation instructions.
- (Side panels not applicable to undercounters).

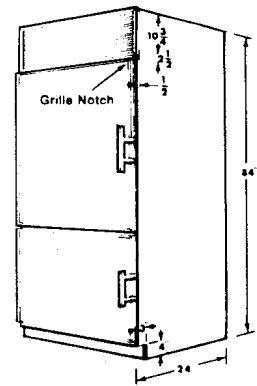

Dimensions given for typical side panel installation. Note: if 1/4" panel is used and inserted into return channel extrusion then a 24-1/2" size is necessary for width. Sheet must also be notched for grille. This is only necessary on this application.

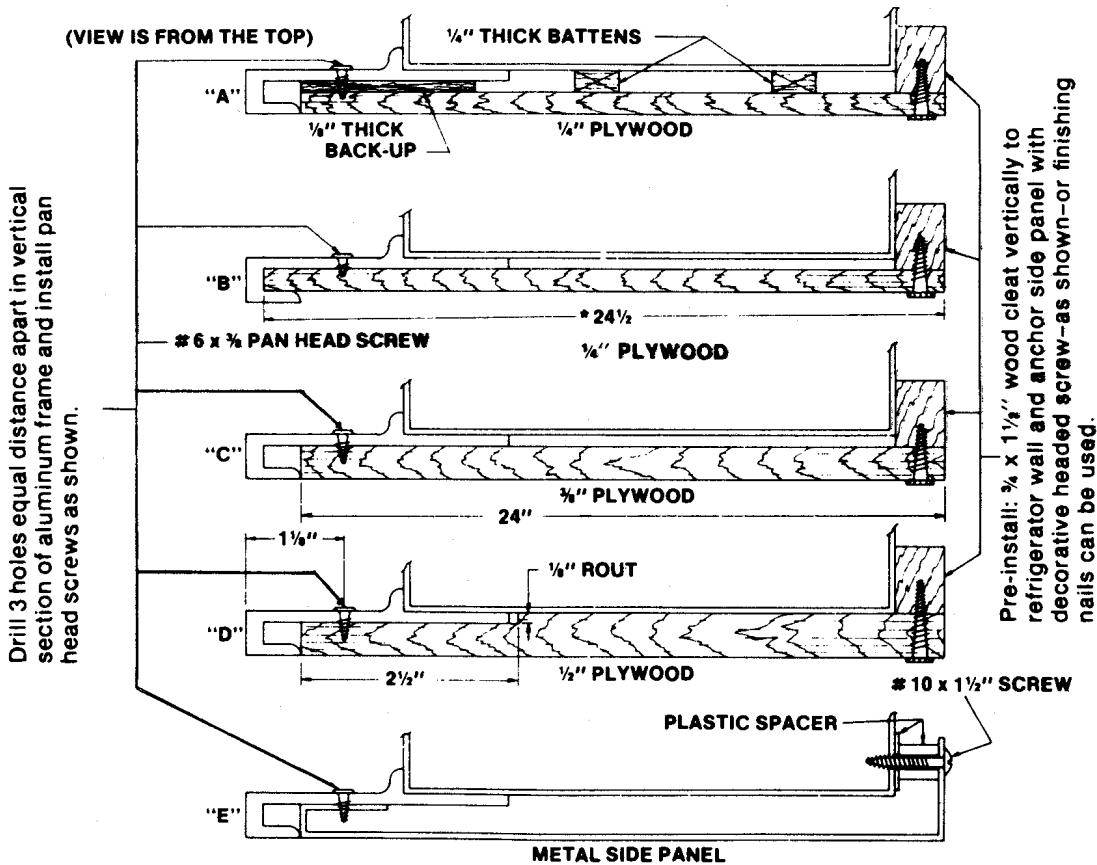

*If 1/4" panel is used and inserted into return channel extrusion, then a 24 1/2" size is necessary for width.

UNDERCOUNTER

All Sub-Zero undercounter units are manufactured in a manner to achieve a total built-in appearance. This allows you to choose the decorative material and color application for the front of your refrigerator/freezer.

To install front panel on all Sub-Zero freezer models:

1. Remove door handle. Handle is located on the top on 221M and 245 models, and on the side on other models. Handle is held on with Phillips head screws.
2. Slide 1/4" thick panel into frame on door. Door must be open 90° on 245 models. If a thinner panel is used, install chipboard filler panels behind the trim panel for proper fit. IMPORTANT: Routing may be required on some panels for finger clearance under handle.
3. With panel in position, replace handle. Replace and tighten all screws. Do not overtighten and 'strip' screws. Refer to Figure E schematic drawing for front panel dimensions.

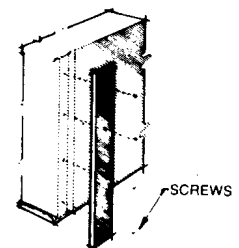
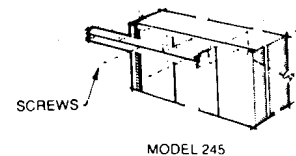
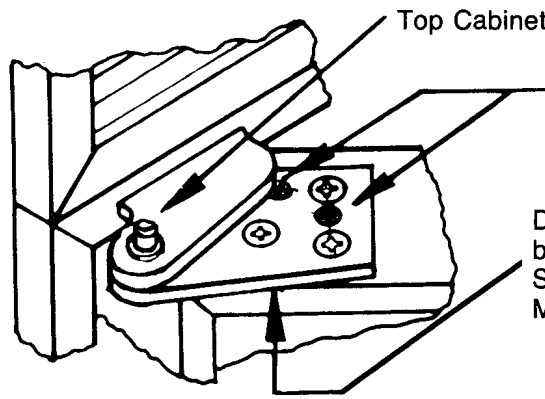

Figure D - HINGE ADJUSTMENT - FULL SIZE



Top Cabinet Hinge — No Adjustment

NOTE: Two Smaller Screws Have Been Used As Shipping Screws. If Adjustment Is Necessary, Remove and Discard Both Screws and Proceed With Adjustment As Listed.

Door Hinge — Can Be Adjusted From Left To Right, In and Out, by Loosening The Three Phillips Head Screws. Center Mullion Stationary Hinge — No Adjustment. Refrigerator and Freezer Mullion Hinges Adjusted Same As Refrigerator Top Hinge.

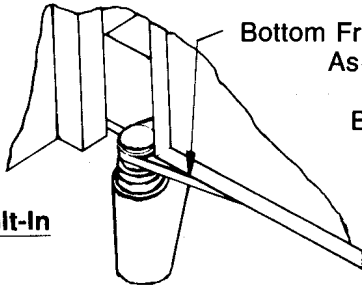

Bottom Freezer Door Hinge Same As Top Refrigerator Hinge.

Bottom Cabinet Hinge — No Adjustment

Built-In

Free-Standing

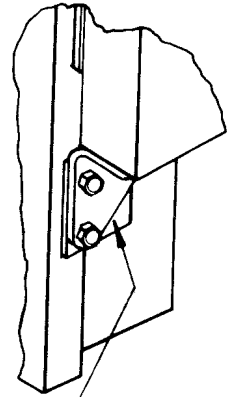

Loosen Screws to Readjust. Can Be Adjusted By Shimming. No Top Adjustment.

UNDERCOUNTER

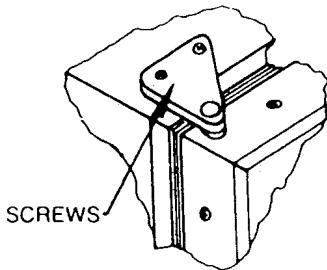

SCREWS

Models 244 and 249: Top and Bottom hinges can be adjusted left to right, in & out, by loosening the two phillips head screws. Models 22IM and 245: Hinges are factory set; no field adjustment provided for.

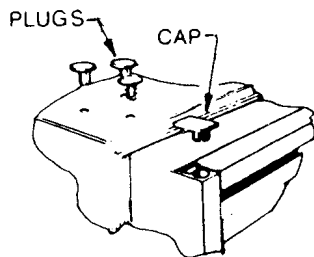

PLUGS

CAP

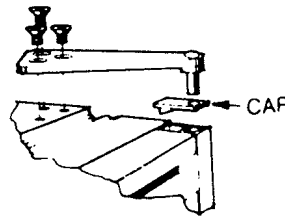

CAP

245 Upper Swing Change

SWING CHANGE

Models 244 and 249: Contact Sub-Zero for swing change kit. Model 245: Upper; interchange hinge, screws and corner cap on opposite side of cabinet and door. Lower; interchange hinge and screws with hole plugs on opposite side of cabinet. Move closer cam, screw and cam support plate to opposite side of door. DO NOT remove mating closer cam from closer hinge plate.

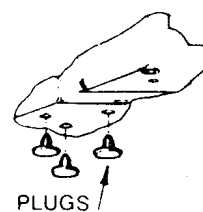

PLUGS

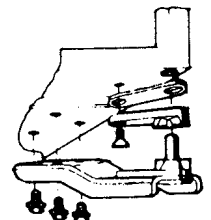

245 Lower Swing Change

Figure E Table

MODEL #	ROUGH OPENING DIMENSIONS		RECOMMENDED ELECTRICAL OUTLET LOCATION		WATER SUPPLY LOCATION	DOOR PANEL DIMENSIONS
	A	B	C	D	E	
201R	35-1/2"	72-3/4"	18"	3-1/2"		34-1/8" x 58-15/16"
2011ICE	35-1/2"	72-3/4"	18"	3-1/2"	18"	34-1/8" x 58-15/16"
201FD	35-1/2"	72-3/4"	18"	3-1/2"	18"	34-1/8" x 58-15/16"
211	29-1/2"	83-3/4"	15"	79"	15"	28-1/8" x 41-7/16" & 28-1/8" x 25-3/8"
241	35-1/2"	83-3/4"	18"	79"	18"	34-1/8" x 41-7/16" & 34-1/8" x 25-3/8"
2711	35-1/2"	83-3/4"	18"	79"	18"	34-1/8" x 41-1/16" & 34-1/8" x 25-3/8"
2811	35-1/2"	83-3/4"	18"	79"	18"	34-1/8" x 48-1/16" & 34-1/8" x 18-3/8"
251	35-1/2"	83-3/4"	18"	79"	18"	34-1/8" x 48-7/16" & 34-1/8" x 18-3/8"
2511	35-1/2"	83-3/4"	18"	79"	18"	34-1/8" x 48-7/16" & 34-1/8" x 18-3/8"
361	35-1/2"	83-3/4"	18"	79"	18"	14-5/8" x 67-11/16" & 19-1/8" x 67-11/16"
3211	47-1/2"	83-3/4"	18"	79"	18"	17-15/16" x 67-11/16" & 27-11/16" x 67-11/16"
801	35-1/2"	34-1/2"	18"	79"	18"	16-7/8" x 22-7/8" (both)
215R	35-1/2"	69-1/2"	18"	14"		--
215FD	35-1/2"	69-1/2"	18"	14"	18"	--
244	24"	34-1/2"	5"	14"	18"	23-5/8" x 30"
249R	24"	34-1/2"	12"	14"		23-5/8" x 30"
249RP	24"	34-1/2"	12"	14"		23-5/8" x 30"
249FF	24"	34-1/2"	5"	14"	18"	23-5/8" x 30"
22IM	12"	34-1/2"	6"	6"	6"	11-9/16" x 30"
505IS	18"	34-1/2"	6"	6"	11"	17-1/32" x 12-31/32"

NOTE: Water line may come directly through the wall, not higher than 2-1/2" from floor level.

Figure E. SCHEMATIC DRAWING

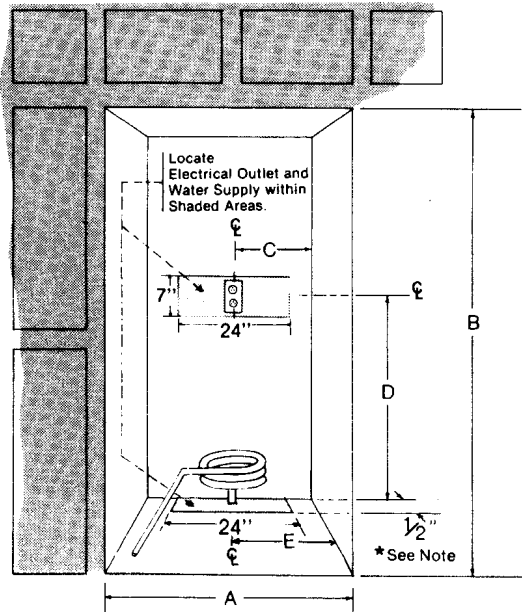

FULL SIZE UNITS

INSTALLATION CHECK LIST

Your Sub-Zero equipment is now installed.

We suggest you go through the following checklist:

- 1. Is unit operating? If not: is unit plugged in, is fuse or breaker blown?, refrigerator/freezer control on?
- 2. Is unit leveled properly (if not refer to step 7)?
- 3. Is door adjusted? (step 11)
- 4. Is water turned on to icemaker and ice bucket in position? (step 8)
- 5. Is packaging material removed (tape and clips)?
- 6. Is toe plate installed? (step 8)
- 7. Is grille screw back in position? (step 9)
- 8. Are panels installed correctly? (step 10)
- 9. Give customer warranty packet.

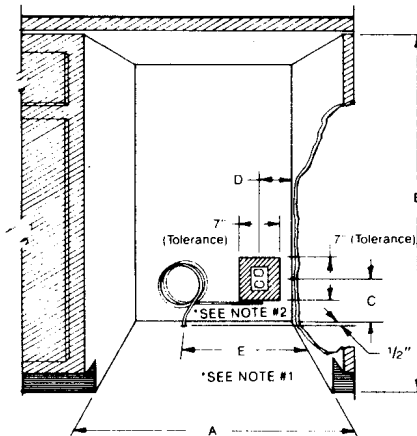

UNDERCOUNTER UNITS

M-Prefix Before Serial No.
Madison Equipment
P-Prefix Before Serial No.
Phoenix Equipment

SECTION 4 **SUB-ZERO MODELS**

SUB-ZERO
MODELS



SUB-ZERO MODELS PRODUCED SINCE 1959

Model	1959	1960	1961	1962	1963	1964	1965-1966	1967	1968	1969-70-71	1972	1974	1979-81	1982	1983	1984	1985	1986	1987	1988	1989	1990-91
R	13081RF	13081RF	13081RF-U	13081RF-U	13081RF-U	13081RF-U	13081RF-U	13081RF-U	13081RF-U	13081RF-U	13081RF-U	13081RF-U	13081RF-U	13081RF-U	13081RF-U	13081RF-U	13081RF-U	13081RF-U	13081RF-U	13081RF-U	13081RF-U	13081RF-U
F	13081RF	13081RF	13081RF-U	13081RF-U	13081RF-U	13081RF-U	13081RF-U	13081RF-U	13081RF-U	13081RF-U	13081RF-U	13081RF-U	13081RF-U	13081RF-U	13081RF-U	13081RF-U	13081RF-U	13081RF-U	13081RF-U	13081RF-U	13081RF-U	13081RF-U
BT	13081RF	13081RF	13081RF-U	13081RF-U	13081RF-U	13081RF-U	13081RF-U	13081RF-U	13081RF-U	13081RF-U	13081RF-U	13081RF-U	13081RF-U	13081RF-U	13081RF-U	13081RF-U	13081RF-U	13081RF-U	13081RF-U	13081RF-U	13081RF-U	13081RF-U
U & C	13081RF	13081RF	13081RF-U	13081RF-U	13081RF-U	13081RF-U	13081RF-U	13081RF-U	13081RF-U	13081RF-U	13081RF-U	13081RF-U	13081RF-U	13081RF-U	13081RF-U	13081RF-U	13081RF-U	13081RF-U	13081RF-U	13081RF-U	13081RF-U	13081RF-U
D & DU	13081RF	13081RF	13081RF-U	13081RF-U	13081RF-U	13081RF-U	13081RF-U	13081RF-U	13081RF-U	13081RF-U	13081RF-U	13081RF-U	13081RF-U	13081RF-U	13081RF-U	13081RF-U	13081RF-U	13081RF-U	13081RF-U	13081RF-U	13081RF-U	13081RF-U
IC	13081RF	13081RF	13081RF-U	13081RF-U	13081RF-U	13081RF-U	13081RF-U	13081RF-U	13081RF-U	13081RF-U	13081RF-U	13081RF-U	13081RF-U	13081RF-U	13081RF-U	13081RF-U	13081RF-U	13081RF-U	13081RF-U	13081RF-U	13081RF-U	13081RF-U
RP	13081RF	13081RF	13081RF-U	13081RF-U	13081RF-U	13081RF-U	13081RF-U	13081RF-U	13081RF-U	13081RF-U	13081RF-U	13081RF-U	13081RF-U	13081RF-U	13081RF-U	13081RF-U	13081RF-U	13081RF-U	13081RF-U	13081RF-U	13081RF-U	13081RF-U
FF	13081RF	13081RF	13081RF-U	13081RF-U	13081RF-U	13081RF-U	13081RF-U	13081RF-U	13081RF-U	13081RF-U	13081RF-U	13081RF-U	13081RF-U	13081RF-U	13081RF-U	13081RF-U	13081RF-U	13081RF-U	13081RF-U	13081RF-U	13081RF-U	13081RF-U
IM, IS, ISC	13081RF	13081RF	13081RF-U	13081RF-U	13081RF-U	13081RF-U	13081RF-U	13081RF-U	13081RF-U	13081RF-U	13081RF-U	13081RF-U	13081RF-U	13081RF-U	13081RF-U	13081RF-U	13081RF-U	13081RF-U	13081RF-U	13081RF-U	13081RF-U	13081RF-U
EX	13081RF	13081RF	13081RF-U	13081RF-U	13081RF-U	13081RF-U	13081RF-U	13081RF-U	13081RF-U	13081RF-U	13081RF-U	13081RF-U	13081RF-U	13081RF-U	13081RF-U	13081RF-U	13081RF-U	13081RF-U	13081RF-U	13081RF-U	13081RF-U	13081RF-U
IFF	13081RF	13081RF	13081RF-U	13081RF-U	13081RF-U	13081RF-U	13081RF-U	13081RF-U	13081RF-U	13081RF-U	13081RF-U	13081RF-U	13081RF-U	13081RF-U	13081RF-U	13081RF-U	13081RF-U	13081RF-U	13081RF-U	13081RF-U	13081RF-U	13081RF-U
RIM	13081RF	13081RF	13081RF-U	13081RF-U	13081RF-U	13081RF-U	13081RF-U	13081RF-U	13081RF-U	13081RF-U	13081RF-U	13081RF-U	13081RF-U	13081RF-U	13081RF-U	13081RF-U	13081RF-U	13081RF-U	13081RF-U	13081RF-U	13081RF-U	13081RF-U
D	13081RF	13081RF	13081RF-U	13081RF-U	13081RF-U	13081RF-U	13081RF-U	13081RF-U	13081RF-U	13081RF-U	13081RF-U	13081RF-U	13081RF-U	13081RF-U	13081RF-U	13081RF-U	13081RF-U	13081RF-U	13081RF-U	13081RF-U	13081RF-U	13081RF-U
ICE	13081RF	13081RF	13081RF-U	13081RF-U	13081RF-U	13081RF-U	13081RF-U	13081RF-U	13081RF-U	13081RF-U	13081RF-U	13081RF-U	13081RF-U	13081RF-U	13081RF-U	13081RF-U	13081RF-U	13081RF-U	13081RF-U	13081RF-U	13081RF-U	13081RF-U

NUMBER & LETTER KEY:

- R Refrigerator
- F Freezer
- BT Built-In
- U & C Freezer not frost free
- D & DU Deluxe frost free freezer
- IC Ice Cream
- RP Plate evaporator-no ice making facility
- FF Frost free freezer
- IM, IS, ISC Icemaker, Icemaker w/standard or cublet grid
- EX Executive
- IFF Icemaker frost free
- RIM All refrigerator w/icomaker
- D Drawer type freezer
- ICE All refrigerator w/icomaker

PRODUCTION DATE & SERIAL NUMBER CORRELATION

The following is an approximate listing of Sub-Zero Serial Numbers produced in their respective years. Please contact the factory should a definite date be needed to determine warranty status:

- January 1, 1970 to December 31, 1970 #133691-138032
- January 1, 1971 to December 31, 1971 #138033-145169
- January 1, 1972 to December 31, 1972 #145170-156333
- January 1, 1973 to December 31, 1973 #156334-168250
- January 1, 1974 to December 31, 1974 #168251-185289
- January 1, 1975 to December 31, 1975 #185290-196065
- January 1, 1976 to December 31, 1976 #196066-212946
- January 1, 1977 to December 31, 1977 #212947-236476
- January 1, 1978 to December 31, 1978 #236477-265836
- January 1, 1979 to December 31, 1979 #265837-294351
- January 1, 1980 to December 31, 1980 #294352-331262
- January 1, 1981 to December 31, 1981 #331263-366779
- January 1, 1982 to December 31, 1982 #366780-407056
- January 1, 1983 to December 31, 1983 #407057-450463
- January 1, 1984 to December 31, 1984 #450464-498349
- January 1, 1985 to December 31, 1985 #498350-532284
- January 1, 1986 to December 31, 1986 #532285-613652
- *January 1, 1987 to December 31, 1987 #613653-678565
- January 1, 1988 to December 31, 1988 #678566-750222
- January 1, 1989 to December 31, 1989 #750223-821300
- January 1, 1990 to December 31, 1990 #821301-893745
- January 1, 1991 to December 31, 1991 #893746-954019

*Starting January 1, 1987, Sub-Zero now indicates the production month and year on each Model I & Serial Number tag

CHAMBERS TO SUB-ZERO MODEL CROSS REFERENCE

- CHAMBERS
- Exec. 500
- RFD 400
- RFD 400
- 300-UCI
- UCI-500
- RID-200-204-205
- RI-200-204-205
- RFID-190-194-195
- RFI-190-194-195
- RI-180-184-185
- FID-180-184-185
- FI-180-184-185
- RFID-170-174-175
- RFI-170-174-175
- RFD-150
- 4877RFD
- RFDI-270
- RFD-500
- RI-120-124-125
- FI-120-124-125
- RI-120-124-125
- RO-120-124-125

CHAMBERS

SUB-ZERO

- Exec. 500
- 145RF-RFC-RFD
- 203UC-I-U
- 199I
- 170BIRF-DU & 173BIRF-DU
- 170BIRF-U & 173BIRF-U
- 130BIRF-DU & 133BIRF-DU
- 130BIRF-U & 133BIRF-U
- 160BIR- & 163BIR-U
- 160BIR-DU & 163BIR-DU
- 1253-DU & 1254-DU
- 1253-U & 1254-U
- 307RFD
- 4877RFD
- 427RFD
- 113BIF-U
- 113BIF-DU
- 113BIR-U
- 113BIR

M-Prefix Before Serial No.
Madison Equipment
P-Prefix Before Serial No.
Phoenix Equipment

SECTION 5

ICEMAKER AND AUTOMATIC DEFROST INFORMATION

ICEMAKER AND AUTOMATIC DEFROST INFORMATION

SUB-ZERO

AUTOMATIC DEFROST SPECIFICATIONS

All freezer sections go through an automatic or timed defrost to clear the frost off the freezer evaporator coil.

This defrost cycle occurs **approximately every 12 hours for about 15 minutes + or - 3 minutes**).

MADISON PRODUCTION - Defrost occurs every 12 hours.

PHOENIX PRODUCTION - Defrost occurs every 12 hours of compressor run.

The part number for the defrost timer is 3-08-105-0.

The defrost terminating thermostat closes at 30 degrees Fahrenheit and opens at 55 degrees Fahrenheit.

The part number for the defrost terminator is 4-32-093-0.

TEST CYCLING THE MODULAR ICEMAKER

CAUTION

DO NOT MANUALLY ADVANCE EJECTOR ARMS OR THE DRIVE GEAR AS IT WILL DESTROY THE MAIN ASSEMBLY

Although the icemaker looks about the same as the compact icemaker from the outside, some significant electrical design changes have been made behind the cover and in the control box area.

WARNING

The design of this icemaker allows all of the components to be tested without removing the icemaker. Repairs should be completed by a factory authorized service agency.

Remove the cover and you will see the test points identified on the module

N = Neutral Side of Line
M = Motor Connection
H = Heater Connection
T = Thermostat Connection
L = L1 Side of Line
V = Water Valve Connection

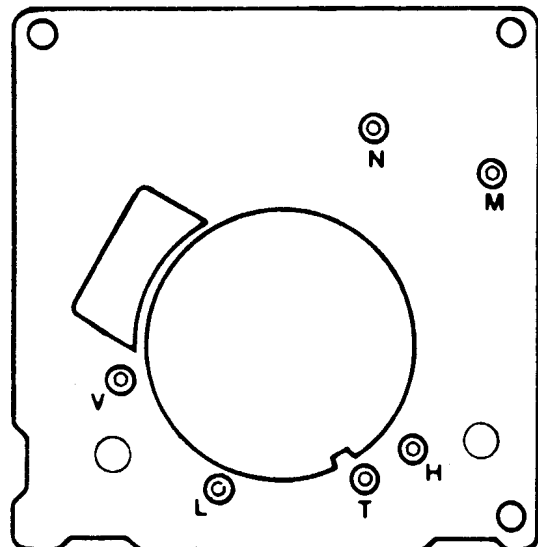
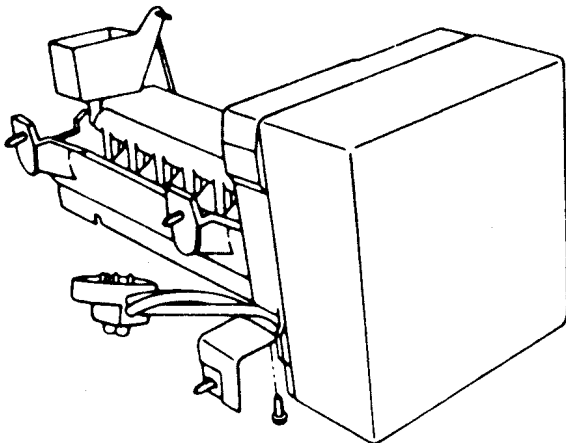

1. ICEMAKER PLUGGED INTO POWER; SHUT-OFF ARM DOWN; FREEZER COLD
 - a. Test points L & N will verify 120 volts to icemaker module. (Make sure your test probes go into the test points 1/2").
 - b. Test points T & H will verify if the bimetal thermostat is open or closed.
 - c. Short T & H with an insulated peice of wire (14 gauge) to run the motor. If the motor doesn't run, replace the module assembly; if the motor runs, replace the bimetal thermostat.
 - d. If you leave the jumper in for half of a revolution, you can feel the heater in the mold heat up. . . if it's good.
 - e. Remove the jumper and the water valve will be energized in the last half of the revolution. (Make sure that the freezer temperature is cold enough to close the bimetal).

Note: Do not short any contact other than those specified as damage to the icemaker can result.

2. ICEMAKER UNPLUGGED
 - a. Test points L & H will check the resistance of the heater (72 ohms). Replace the mold and heater assembly if not near this valve (± 10 ohms). (Ejector blades should be at the end of the cycle position or the 1:30 o'clock position).

MODULAR BREAKDOWN

200/300 Series Part #4-20-052-0 Complete Icemaker Assembly

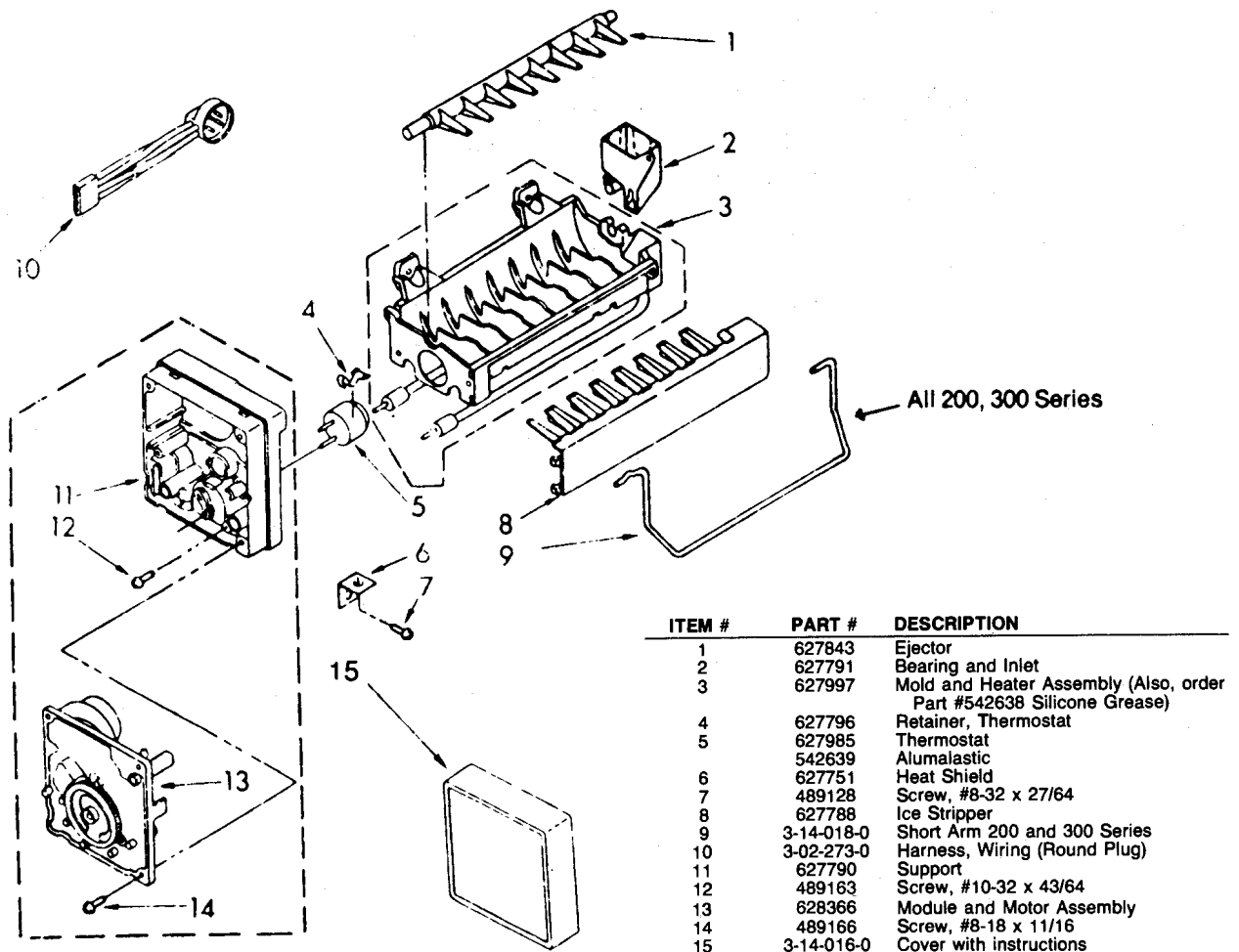

TROUBLE DIAGNOSIS AND CHECKING PROCEDURE FOR MODULAR ICEMAKERS

COMPLAINT	PROBABLE CAUSE	CORRECTION
No Ice	1. Freezer warmer than 10 degrees F	1. Repair freezer
	2. Arm up	2. Free arm and/or lower, turn icemaker switch on, or have ice bucket in place
	3. No power to icemaker	3a. Loose wire in plastic connector at modular head b. Loose plastic connector at modular housing c. Bad fuse wire—repair or replace
	4. No water to icemaker	4a. *Water supply off b. *Replace self-piercing valve c. Replace water valve d. *Thaw frozen inlet f. Replace modular head
	5. Icemaker fails to complete cycle	5a. Replace modular head b. Replace mold/heater assy
LOW ICE	1. Freezer warmer than 10 degrees F	1. Repair freezer
	2. Arm operation intermittent	2. Free arm and/or lower
	3. Water supply problem	3a. *Check water supply for adequate pressure to water valve (20P.S.I.) b. *Replace self-piercing valve c. Adjust for proper water fill during the fill cycle
	4. Hollow cubes	4a. Thermostat short cycling—replace thermostat b. Add alumalastic cement
TOO MUCH ICE	1. Arm stuck in down position	1. Free arm
	2. Broken shut-off arm activator (in modular head)	2. Replace modular head
	3. Too much water	3a. Water valve continues to fill after cycle is completed—adjust water fill cycle b. Replace water valve—if bad
	4. Icemaker fails to stop at end of cycle	4. Replace modular head
	5. Hollow cubes	5a. Adjust water fill b. Replace thermostat

*Not covered by factory warranty

TEST CYCLING THE COMPACT ICEMAKER

It may be necessary on occasion to test-cycle an icemaker to check its operation. This can be done on the repair bench or while mounted in the appliance.

If the icemaker is in an operating appliance, take precaution against condensate by allowing the cold metal components to warm before the front cover. The appliance cabinet wiring can be used to operate the icemaker.

A special icemaker test cord can be made for bench repair using the cabinet icemaker connector. The same cord made for the 'Remote Valve' type icemaker can be used (see figure A).

To manually start a cycle, first remove the front cover by prying loose with a coin at the bottom of the support. Please use the blade of a flat screwdriver in the slot located on the drive gear (see figure B). Turn counter-clockwise until the holding switch clicks in and circuit is made to the icemaker motor. The icemaker will then complete its cycle itself.

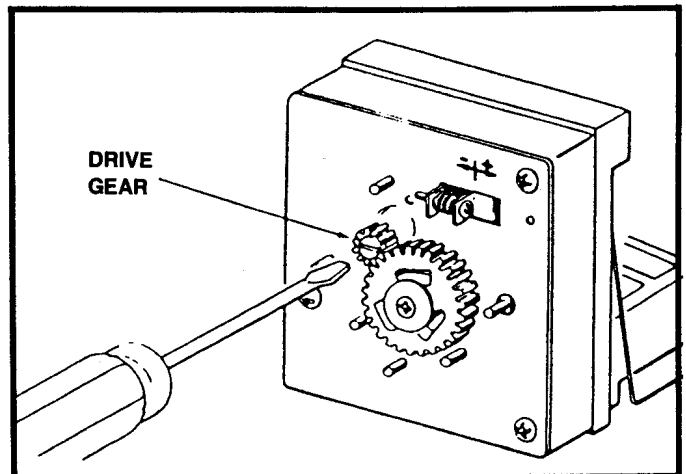
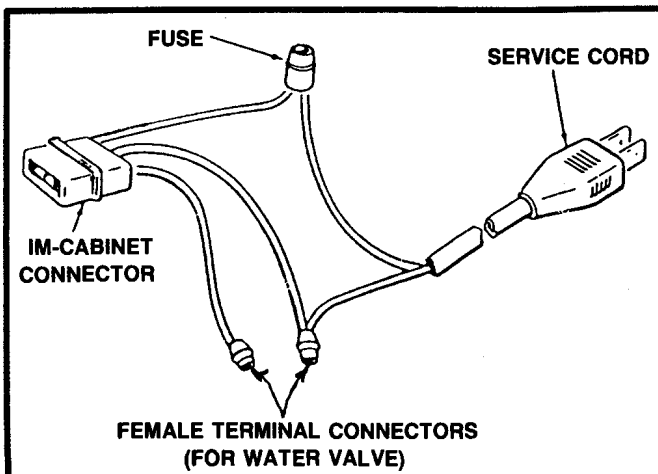

**4-20-031-0
COMPLETE ICEMAKER ASSEMBLY**

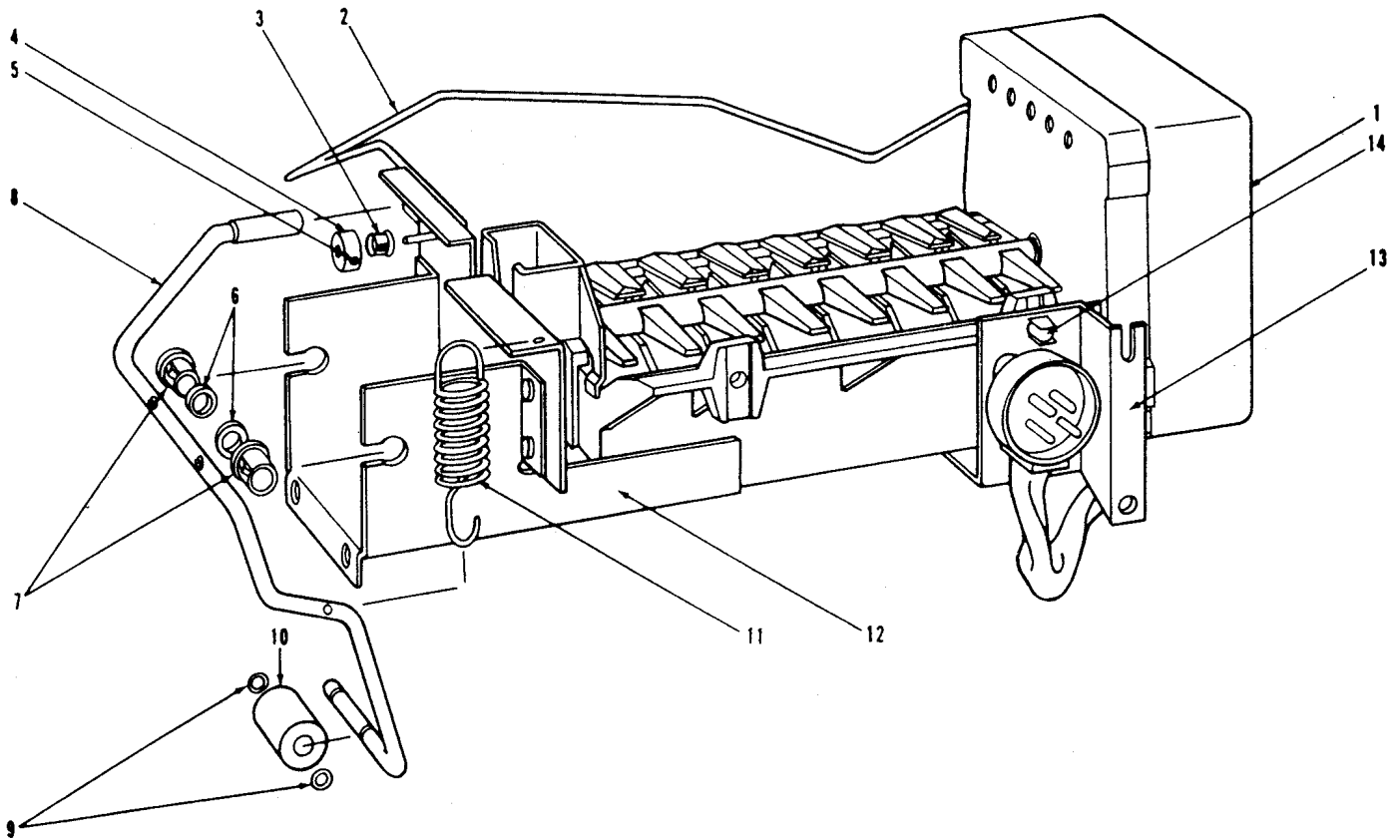

<u>Item #</u>	<u>Part #</u>	<u>Description</u>
1	4-20-031-0	Icemaker Assembly
2	2-8094-01	Shut-Off Arm
3	3-22-020-0	Snap Bushing 1/4 x 1/8
4	3-45-042-0	Shaft Collar
5	6-11-050-0	Set Screw, #8-32 x 3/16
6	6-24-018-0	Nylon Washer .437 x .260
7	3-22-018-0	Snap Bushing, 3/8 x 1/4
8	3-42-087-0	Icemaker Arm Guide
9	3-45-033-0	Plastic O-Ring, .145 x .070
10	3-42-088-0	Roller, .75 x .25 x 1.0
11	3-45-036-0	Extension Spring, .75 x .055 x 2.0
12	4-16-039-0	IM Sensor Return Mechanism
13	0-23234-0	IM Bracket
14	6-22-022-0	Screw Grommet, 1/32 x 3/8 sq

**COMPACT ICEMAKER #3-14-001-0
8 CAVITY**

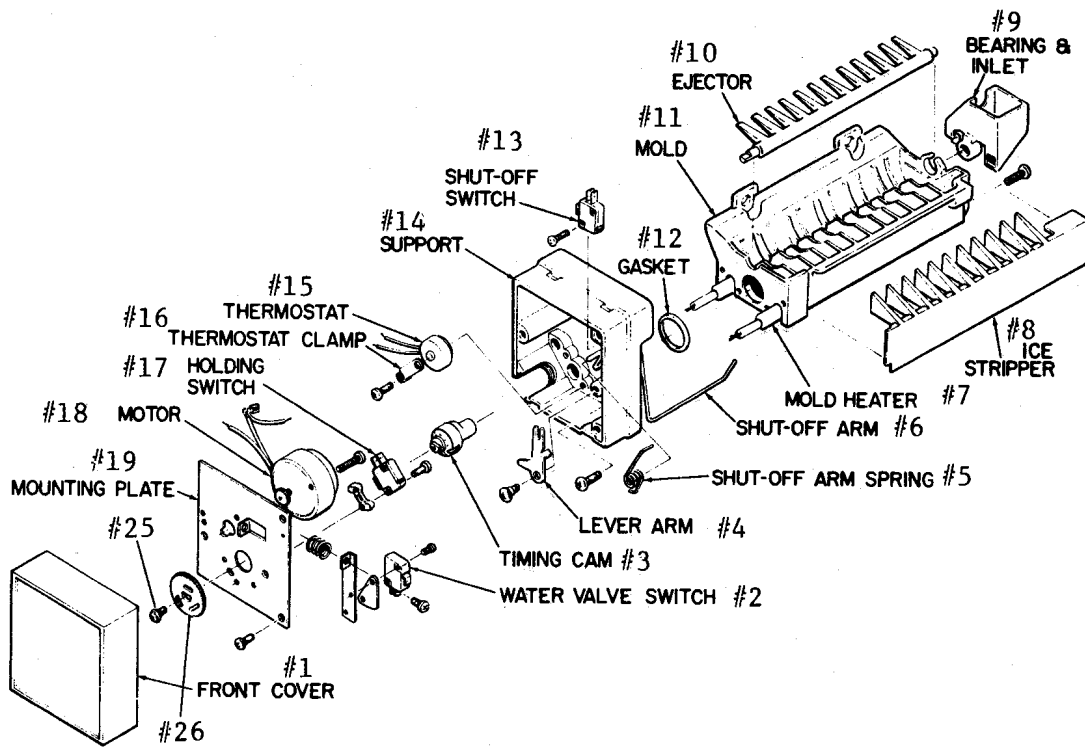

<u>Item #</u>	<u>Part #</u>	<u>Description</u>	<u>Item #</u>	<u>Part #</u>	<u>Description</u>
1	833873	Front Cover	14	625827	Support
2	627851	Water Switch	15	627180	Thermostat
3	625913	Timing Cam		627333	Thermostat*
4	625830	Lever Arm			(*Canadian use)
5	480855	Shut-off Arm Spring	16	625829	Thermostat
6	627003	Shut-off Arm	17	627848	Holding Switch
7	625893	Mold Heater Kit	18	798654	Motor Kit
8	627753	Ice Stripper	19	625833	Mounting Plate
9	833593	Bearing/Inlet Kit	20	625914	Gear
10	627169	Ejector	21	488806	Screw
11	627170	Mold	22	488787	Screw Mtng Plate
12	625828	Gasket	23	833873	Front Cover
13	625851	Shut-off Switch	24	488896	Screw
			25	488806	Screw
			26	628210	Gear

**ICEMAKER PARTS #3-14-007-0
12 CAVITY**

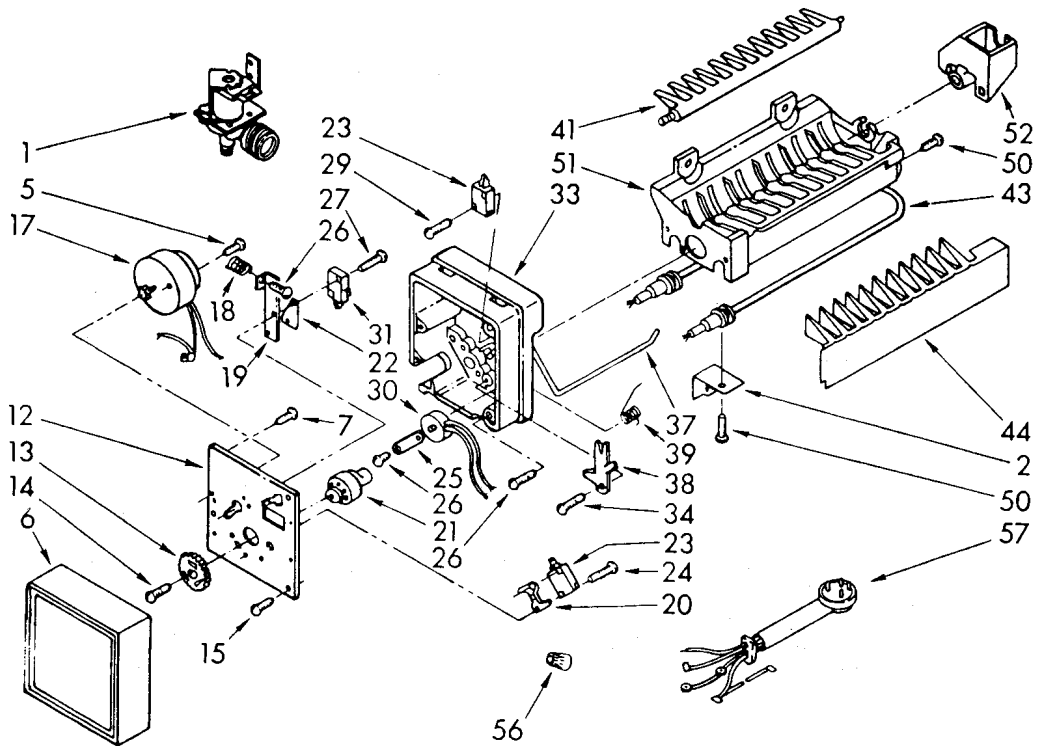

<u>Item #</u>	<u>Part #</u>	<u>Description</u>	<u>Item #</u>	<u>Part #</u>	<u>Description</u>
1	3-09-002-0	Valve Assy	24	488361	Screw, 4-40 x 1
2	625910	Bracket	25	625829	Clamp (alternate)
5	488361	Screw (use w/625846 mtr)	26	488372	Screw, 8-32 x 1
	488622	Screw (use w/627106 mtr)	27	488362	Screw, 4-40 x 3/4
6	833873	Cover	29	488360	Screw, 4-24 x 3/4
7	488542	Screw (ground)	30	627180	Thermostat*
12	625833	Mounting Plate	31	627848	Switch, Holding
13	525914	Gear	33	625827	Support
14	488806	Screw	34	833587	Screw, shoulder
15	488787	Screw, #8-18 x 1/2	37	627003	Arm, Shut-off
17	798654	Motor	38	625830	Arm, Lever
	627106	Motor (alternate)	39	480855	Spring, Shut-off
18	627163	Spring	41	627375	Ejector
19	625836	Plate Valve Switch	43	625893	Heater, Mold
20	625834	Spacer, Holding Sw	44	625840	Ice Stripper
21	625913	Cam	50	488896	Screw, 8-16 x 3/8
22	984683	Insulator	51	833702	Mold/Htr Assy (incl #43)
23	627851	Switch, shut off & water	52	833593	Bearing & Inlet connector, valve
			56	227991	Harness, wiring
			57	627151	

*In Canada, utilize thermostat part #627333

**TROUBLE DIAGNOSIS AND CHECKING PROCEDURE
FOR COMPACT ICEMAKER**

<u>COMPLAINT</u>	<u>PROBABLE CAUSE</u>	<u>CORRECTION</u>
NO ICE	1. Shut-off Arm	1. Check that arm is in lowest position. Lower arm if raised.
	2. No power to icemaker	2. Check for power at black & white ice maker leads. Correct cabinet wiring if defective
	3. Not cold enough	3. Check mold temperature at a mounting screw if above 10 Degrees F, evaporator is not cold enough
	4. Thermostat	4. If mold is below 10 degrees F, manually start icemaker by pushing timing gear. If motor starts, thermostat shut-off switch or holding switch is defective. Check holding switch first-if OK replace thermostat. If motor does not start, check shut-off switch and motor.
	5. Holding switch	5. With ejector blades in starting check terminals "C" & "NC" for continuity. Replace switch if open
	6. Shut-off arm switch	6. Check that linkage is proper, adjust if necessary. Check terminals "NO" & "C" for continuity with arm in lowest position. Replace switch if open
	7. Motor	7. Check operation with test cord. Replace motor if it fails to start
	8. Holding switch-if blades are in 10:00 position	8. With switch plunger depressed, check terminals "C" & "NO" for continuity. Replace switch if open
	9. Shut-off switch-if blades are in 12:00 position	9. Check terminals "C" & "NC" for continuity. Replace switch if open
	10. Mold heater or thermostat-if blades are in 4:00 position	10. Check heater for continuity. Replace heater if open. If heater shows continuity-replace thermostat
	11. Motor	11. Check operation with test cord. Replace motor if it fails to start
	12. Water supply	12. Check that water line, valve & valve strainer are open. Remove restrictions, open valve, or instruct customers accordingly
	13. Water valve	13. Observe inlet tube and fill trough for ice, check water valve for slow leak. If valve leaks, check for proper water line pressure. Replace heater if open. Replace water valve if pressure is within specs
	14. Valve solenoid coil	14. Check terminals for continuity. Replace coil if open or shorted
	15. Water valve switch	15. With plunger out check terminals "C" & "NC" for continuity. Replace switch if open
TOO MUCH ICE	1. Shut-off arm	1. Check that linkage is proper. Switch should open when arm is in raised position. Adjust if required. Check terminals "C" & "NO" for continuity with arm raised. Replace switch if closed
UNDERSIZED ICE PIECES	1. Mold	1. Check for level. Adjust if required
	2. Water supply	2. Check that supply line and water valve strainer are completely open and that adequate pressure is maintained. Clear restrictions or advise customer accordingly
	3. Water valve switch	3. Test-cycle IM and measure water fill. Adjust switch if required
HOLLOW ICE	1. Thermostat short-cycling	1. Check thermostat bond to mold. Assure good thermal contact with alumilastic. Check calibration by replacing with a new part
IM SPILLS WATER FROM MOLD	1. Mold	1. Check for level. Adjust if required. Check top edge for evidence of siphoning. Prevent capillary action using silicone grease in this area
	2. Water inlet tube	2. Check that inlet tube and fill trough fit properly and water doesn't leak during fill cycle. Adjust fit if required
	3. Water valve	3. Check that water doesn't enter mold after cycle is completed. Replace valve if leaking and water pressure is proper
	4. Water valve switch	4. Test-cycle IM and check that water fill doesn't exceed capacity of mold. Adjust switch if required. With ejector blades in starting position, check terminals "C" & "NC". Replace switch if closed
	5. IM fails to stop at end of cycle	5. Refer to complaint "Fails to stop at end of cycle"
	6. Thermostat short-cycling	6. Refer to complaint "Undersize ice pieces"
ICEMAKER FAILS TO STOP AT END OF CYCLE	1. Holding switch	1. With ejector blades in starting position, check terminals "C" & "NO" for continuity. Replace switch if closed

M-Prefix Before Serial No.
Madison Equipment
P-Prefix Before Serial No.
Phoenix Equipment

SECTION 6
SEALED SYSTEM AND
TECHNICAL INFORMATION

SEALED SYSTEM
AND TECHNICAL
INFORMATION



SUB-ZERO SYSTEM AND CONTROL DATA - REPLACEMENT PARTS - LISTING

Enclosed you will find a quick reference replacement parts and specification listing. The listing is broken down into three major categorical groups by serial number.

GROUP ONE includes Hot Gas System up to the Energy Design Systems.

GROUP TWO includes the Energy Design System and continues up to the Rocker Switch Change.

GROUP THREE begins with the Rocker Switch Change and continues up to the discontinuation of the 200/300 Series models.

GROUP FOUR begins with the Rocker Switch Change and up to the present.

On page 6-3 there is a sealed system reference sheet. This listing provides the refrigerant charge and suction pressures for each group.

In the past we have had requests for more specific control data. In an effort to refamiliarize you with the controls and their specifications, below you will find the necessary information on the Sub-Zero controls with a normal cut-in and cut-out (at about a #4 setting), a cold cut-in and cut-out (at about a #7 setting) and a warm cut-in and cut-out (at about a #1 setting). This should be helpful in diagnosing a control problem.

On any control change, be sure the control bulb is properly clamped to the evaporator and no portion of the control bulb is touching the evaporator.

PLEASE NOTE: Refer to the parts manual and/or the listing below to locate which control is used on which piece of equipment.

<u>PART #</u>	<u>NORMAL #4</u>		<u>COLD #7</u>		<u>WARM #1</u>	
	<u>CUT-OUT</u>	<u>CUT-IN</u>	<u>CUT-OUT</u>	<u>CUT-IN</u>	<u>CUT-OUT</u>	<u>CUT-IN</u>
3-01-201-0	+11.5	+28.0	+ 3.0	+27.0	+20.0	+31.0
3-01-204-0	+37.0	+44.0	+34.0	+40.0	+41.0	+48.0
3-01-206-0	- 8.0	+ 7.0	-21.0	+ 6.0	+ 3.5	+17.0
3-01-207-0	-10.0	+38.0	-23.0	+38.0	+ 1.5	+38.0
3-01-229-0	+48.0	+55.0	+44.0	+51.0	+52.0	+59.0
3-01-230-0	+16.0	+38.0	+ 8.0	+38.0	+27.5	+38.0
3-01-234-1	+ 2.0	+38.0	-13.5	+38.0	+17.0	+38.0
3-01-238-0	+ 0.0	+10.0	- 5.0	+ 5.0	+ 4.0	+14.0
3-01-239-0	+36.5	+41.0	+33.0	+37.5	+30.5	+44.0
3-01-244-0	+ 0.0	+10.0	- 5.0	+ 6.0	+ 5.0	+14.0
3-01-245-0	- 7.0	+ 4.0	-20.5	- 3.0	+ 6.0	+16.0
3-01-246-0	+17.0	+38.0	+ 9.0	+40.0	+32.0	+43.0
3-01-247-0	-10.0 (9 0'clock posit)	+18.0	-22.0 (5 0'clock posit)	+ 1.0	+ 9.0 (7 0'clock posit)	+23.0
3-01-250-0	+37.0	+44.0	+34.0	+40.0	+41.0	+48.0
3-01-252-1	- 8.0	+ 7.0	+21.0	+ 6.0	+ 3.5	+17.0
3-01-278-0	- 9.0	- 6.0	-22.0	- 7.0	+ 1.0	+16.0

200/300 SERIES AIR FLOW

The schematics shown below indicate air flow for our over and under models (211, 241, 251, 2711, 2811) and the side-by-side models (361, 3211) respectively.

211, 241, 251, 2711, 2811

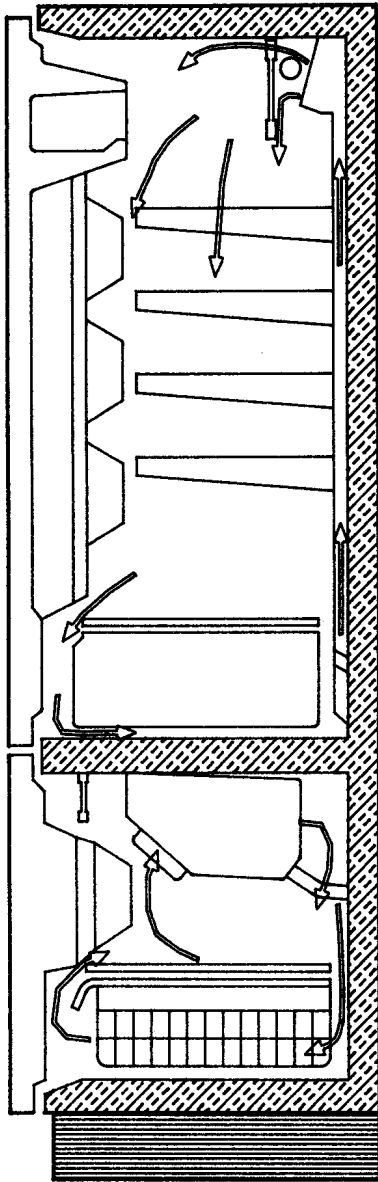

361, 3211

FREEZER

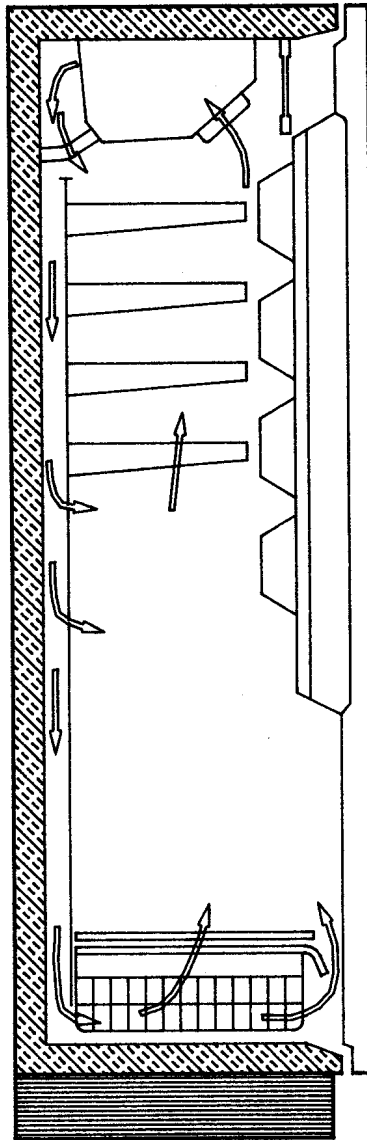

REFRIGERATOR

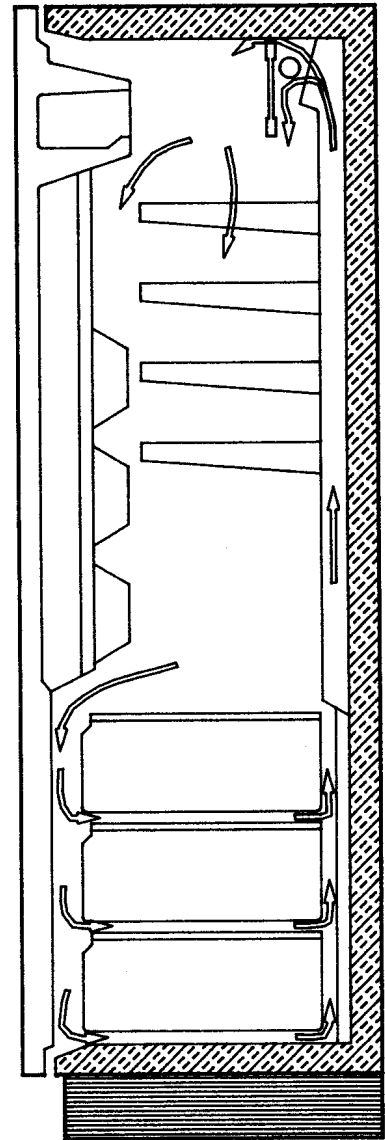

SERIAL NUMBER BREAKS

Model #	GROUP #1			GROUP #2			GROUP #3			GROUP #4		
	Serial Numbers			Serial Numbers			Serial Numbers			Serial Numbers		
211	Prior to #227972			#227972-298402			#298492-M393733/P397233			#M393733/P397233-Present		
361	Prior to #227972			#227972-299352			#299352-M393733/P397233			#M393733/P397233-Present		
241	Prior to #227972			#227972-303252			#303252-M393733/P397233			#M393733/P397233-Present		
3211R	Prior to #227972			#227972-299652			#299652-M393733/P397233			#M393733/P397233-Present		
3211F	Prior to #227972			#227972-299652			#299652-M393733/P397233			#M393733/P397233-Present		
2511R	Prior to #227972			#227972-300252			#300252-M393733/P397233			#M393733/P397233-Present		
2511F	Prior to #227972			#227972-300252			#300252-M393733/P397233			#M393733/P397233-Present		
2711R	-----			-----			#368247-M393733/P397233			#M393733/P397233-Present		
2711F	-----			-----			#368247-M393733/P397233			#M393733/P397233-Present		
2811R	-----			-----			-----			#M455970/P455970-Present		
2811F	-----			-----			-----			#M455970/P455970-Present		
251	Prior to #227972			#227972-299952			#299952-M393733/P397233			#M393733/P397233-Present		
201R	Prior to #227972			#227972-M385453/P380052			#M385453/P380052-Present			#M385453/P380052-Present		
201FD	Prior to #227972			#227972-299051			#299051-Present			#299051-Present		
2011ICE R	-----			-----			#393403-Present			#393403-Present		
2011ICE F	-----			-----			#393403-Present			#393403-Present		
215R	Prior to #227972			#227972-380577			#380577-Present			#380577-Present		
215FD	Prior to #227972			#227972-302127			#302127-Present			#302127-Present		
201RIM	-----			-----			#301352-Present			#301352-Present		
249R	Prior to #227972			#227972-301352			#301352-Present			#301352-Present		
249RP	Prior to #227972			#227972-300852			#300852-Present			#300852-Present		
249FF	Prior to #227972			#227972-303052			#303052-M391803/P380477			#M391803/P380477-Present		
244R	Prior to #227972			#227972-295052			#295052-M391603/P380477			#M391603/P380477-Present		
244F	Prior to #227972			#227972-295052			#295052-M391603/P380477			#M391603/P380477-Present		
801R	Prior to #227972			#227972-291867			#291867-Present			#291867-Present		
801F	Prior to #227972			#227972-291867			#291867-Present			#291867-Present		
22IM (old)	-----			#271942-272342			#272342-301252			#301252-509241		
22IM (new)	-----			-----			-----			#509242-Present		
245	-----			-----			-----			#464681-Present		

SEALED SYSTEM CHARGES & PRESSURES

MODEL #	GROUP #1			GROUP #2			GROUP #3			GROUP #4		
	CHARGE	SUCTION	PRESSURE	CHARGE	SUCTION	PRESSURE	CHARGE	SUCTION	PRESSURE	CHARGE	SUCTION	PRESSURE
	R-12	IN	OUT	R-12	IN	OUT	R-12	IN	OUT	R-12	IN	OUT
211	11.5oz	14	2.5	14oz	18	0	14oz	18	0	14oz	18	0
361	11.5	15	1.5	13	15	2	14	15	2	14	15	2
241	11.5	13	.5	15	20	0	14	20	0	14	20	0
3211 R	7.75	36	10.5	10	37	8	8	37	8	*	37	8
3211 F	9.5	11	3.5	14.5	15	1	12	15	1	**	15	1
2511 R	9	37	11	10	37	8	8	37	8	8	37	8
2511 F	11.5	10	2	14.5	15	1	12	15	1	12	15	1
2711 R	---	---	---	---	---	---	13	37	18	13	37	18
2711 F	---	---	---	---	---	---	14	11	4	14	11	4
2811 R	---	---	---	---	---	---	---	---	---	13	37	18
2811 F	---	---	---	---	---	---	---	---	---	14	11	4
251	13	15.5	1.5	15	20	0	14	20	0	14	20	0
201 R	8.5	34.5	7	11	36	8	10	36	8	10	36	8
201 FD	10.5	12	1.5	12	14	1	11	14	1	11	14	1
2011 ICE R	---	---	---	---	---	---	11	37	18	11	37	18
2011 ICE F	---	---	---	---	---	---	7	20	0	7	20	0
215 R	8.5	34.5	7	11	36	8	11	36	8	10	36	8
215 FD	10.5	12	1.5	12	14	1	11	14	1	11	14	1
201 RIM	---	---	---	---	---	---	8.5	30	7	10	30	7
249 R	7	28	5.5	7	26	3	7	26	3	***7	26	3
249 RP	4.75	29	6	4.75	36	6	4.75	36	6	***4.75	36	6
249 FF	7	10	1	7	19	2	7	19	2	***7	19	2
244	7	10	1	7	12	1	7	12	1	10	12	1
801	8.25	12	2	9.5	12	1	9.5	12	1	***9.5	12	1
22IM (OLD)	---	---	---	6.5	35	4	6.5	35	4	5.5	35	4
22IM (NEW)	---	---	---	---	---	---	---	---	---	8.5	15	0
245	---	---	---	---	---	---	---	---	---	***9	12	0
2411R	10	8	37	---	---	---	---	---	---	---	---	---
2411F	14.5	1	15	---	---	---	---	---	---	---	---	---

*Prior to Serial #402308 on the Model #3211 (Ref.) use 8 oz.; After Serial #402308 use 10 oz. - **Prior to Serial #M431260/P429835 (M denotes Madison production & denotes Phoenix production) - ***After Serial #662066 on the Model 245 use 6.0 oz.; after Serial #M65916/P655116 on the Model 249R use 4.0 oz.; after Serial #M659316/P655316 on the Model 249RP use 4.0 oz.; after Serial #M659116 on the Model 801 use 6.0 oz.; after Serial #M662466 on the Model 249FF use 6.0 oz.

NOTE: WHEN REFERRING TO CHARGE ALWAYS REFER TO THE MODEL PLATE FIRST

COMPRESSOR DATA FOR 200/300 SERIES

Model #	GROUP #1			GROUP #2			GROUP #3			GROUP #4						
	AMPS	WATTS	H.P.	B.T.U.	AMPS	WATTS	H.P.	B.T.U.	AMPS	WATTS	H.P.	B.T.U.	AMPS	WATTS	H.P.	B.T.U.
211	**	**	**	**	4.2	483	1/4	1050	4.5	517	1/4	1075	4.5	517	1/4	1075
361	**	**	**	**	4.6	529	1/4	1300	4.5	517	1/4	1075	4.5	517	1/4	1075
241	**	**	**	**	4.6	529	1/4	1300	4.5	517	1/4	1075	4.5	517	1/4	1075
3211R	**	**	**	**	1.8	2071	1/12	320	1.8	207	1/12	320	1.8	207	1/12*	320
3211F	**	**	**	**	2.5	287	1/5	600	2.5	287	1/5	600	3.1	356	1/5	800
2511R	**	**	**	**	1.8	207	1/12	320	1.8	207	1/12	320	1.8	207	1/12	320
2511F	**	**	**	**	2.5	287	1/5	600	2.5	287	1/5	600	2.5	287	1/5	600
2711R	---	---	---	---	---	---	---	---	1.8	207	1/12	320	1.8	207	1/12	320
2711F	---	---	---	---	---	---	---	---	2.5	287	1/5	600	2.5	287	1/5	600
2811R	---	---	---	---	---	---	---	---	1.8	207	1/12	320	1.8	207	1/12	320
2811F	---	---	---	---	---	---	---	---	2.5	287	1/5	600	2.5	287	1/5	600
251	**	**	**	**	4.6	529	1/4	1300	4.5	517	1/4	1075	4.5	517	1/4	1075
201R	**	**	**	**	2.9	333	1/6	1450	2.5	287	1/5	600	2.5	287	1/5	600
201FD	**	**	**	**	4.2	483	1/4	1050	4.5	517	1/4	1075	4.5	517	1/4	1075
2011ICE R	---	---	---	---	---	---	---	---	1.8	207	1/12	320	1.8	207	1/12	320
2011ICE F	---	---	---	---	---	---	---	---	1.8	207	1/12	320	1.8	207	1/12	320
215R	**	**	**	**	2.9	333	1/6	1450	2.5	287	1/5	600	2.5	287	1/5	600
215FD	**	**	**	**	4.2	483	1/4	1050	4.5	517	1/4	1075	4.5	517	1/4	1075
201RIM	---	---	---	---	---	---	---	---	2.5	287	1/5	600	2.5	287	1/5	600
249R	**	**	**	**	1.8	207	1/12	320	1.8	207	1/12	320	1.8	207	1/12	320
249RP	**	**	**	**	1.8	207	1/12	320	1.8	207	1/12	320	1.8	207	1/12	320
249FF	**	**	**	**	2.5	287	1/5	600	2.5	287	1/5	600	1.8	207	1/12	320
244RFD	**	**	**	**	2.5	287	1/5	600	2.5	287	1/5	600	1.8	207	1/12	320
801RFD	**	**	**	**	2.5	287	1/5	600	2.5	287	1/5	600	2.5	287	1/5	600
221M	---	---	---	---	2.5	287	1/5	600	2.5	287	1/5	600	2.5	287	1/5	600
245RFD	---	---	---	---	---	---	---	---	---	---	---	---	1.8	207	1/12	320

*After Serial #M431250/P429835

**Please contact the factory should you require this information

SEALED SYSTEM DIAGNOSIS AND PROCEDURES

This particular service category does require good technical procedures when a diagnosis or repairs are made to the sealed system of our equipment. The following information should assist with most situations you may encounter on our product.

NOTE: On ALL sealed system repairs, it is required that a new filter drier be installed whenever the system is entered.

SYSTEM DIAGNOSIS CHECKLIST:

Typical Sub-Zero Refrigeration System

MODELS - 211, 241, 251, 361
(AFTER SN #227972)

MODELS-3211RFD, 2011ICE, 2511RFD, 2711RFD
AND 2811RFD (AFTER SN#227972)

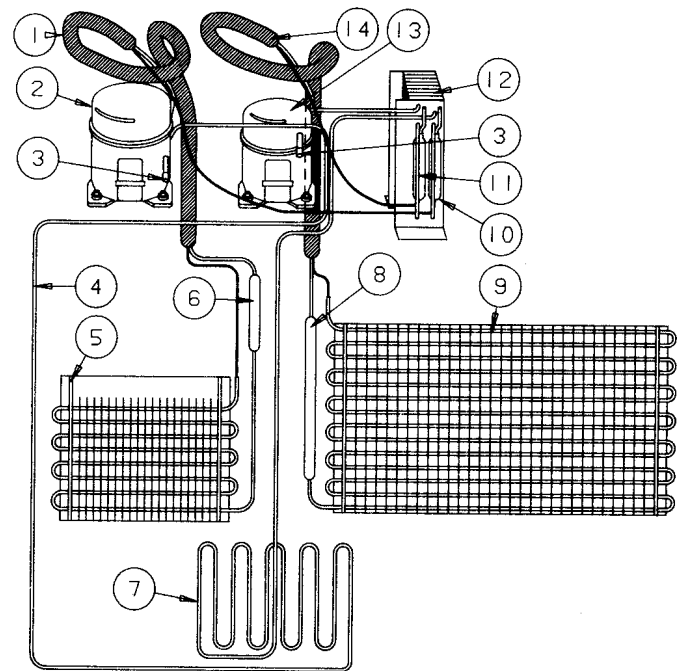
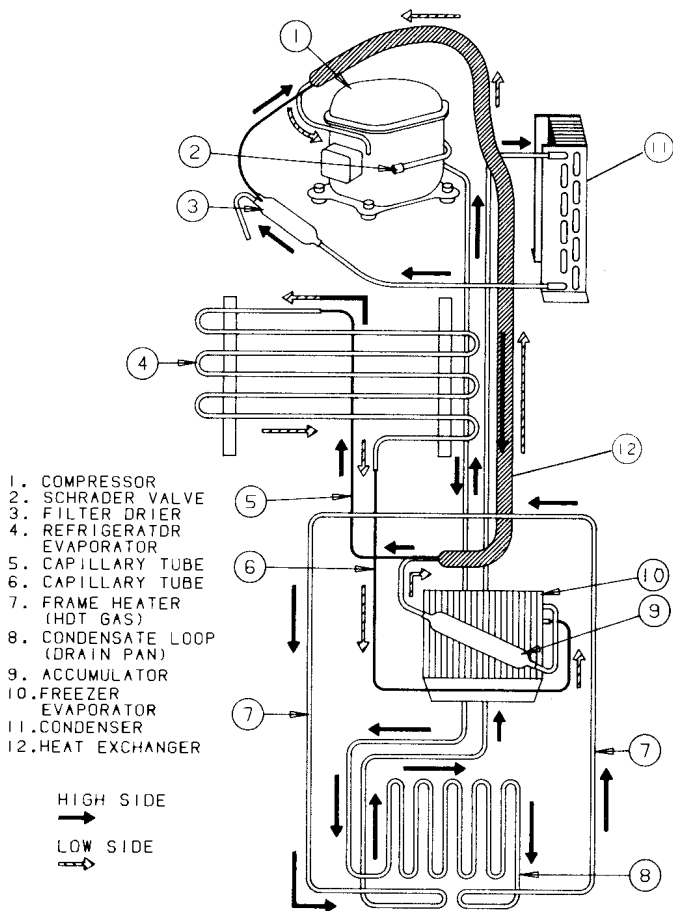

- 1. HEAT EXCHANGER (FREEZER)
- 2. COMPRESSOR (FREEZER)
- 3. SCHRADER VALVE
- 4. FRAME HEATER (HOT GAS)
- 5. EVAPORATOR (FREEZER)
- 6. ACCUMULATOR (FREEZER)
- 7. CONDENSATE LOOP (DRAIN PAN)
- 8. ACCUMULATOR (REFRIGERATOR)
- 9. EVAPORATOR (REFRIGERATOR)
- 10. FILTER DRIER (FREEZER)
- 11. FILTER DRIER (REFRIGERATOR)
- 12. CONDENSER

SEALED SYSTEM LEAK DETECTION PROCEDURES

When diagnosing a leak, we are recommending the use of an electronic leak detector to assist in the simplification of locating the leak. However, another method that can be utilized is the use of a halide torch, but this method could be ineffective in areas where trace amounts of leaking refrigerant are present or where blowing winds are near the work area. Also, the soap bubble test is helpful for finding small leaks in suspected areas.

Leaks can be found in any portion of the sealed system. Therefore, much care must be taken when diagnosing leaks. After many years of accurate detailed monitoring of the sealed systems of our products, the following areas have been found to be areas that should be reviewed:

1. Shrader valve caps.
2. Leak at the filter drier.
3. Leak at the yoderloop (hot gas tubing in diagram).
4. Leak at the compressor joints.
5. Leak at the heat exchanger (be sure to peel back armaflex opening).
6. On all refrigerators - leak where the evaporator enters the accumulator.
7. Refrigerator evaporators - please note that all evaporators on our units are made of copper tubing. Some evaporators are tin-coated to prolong the life of the tubing. The 249R and 249RP utilize an aluminum evaporator with a copper connection.

The recommended leak test procedure is listed as follows:

1. Stop the unit. This is to reduce air movement as much as possible.
2. Choose the leak detection method best suited for the situation.
3. Connect the gauge manifold to the refrigeration system.
4. Be sure that the system has at least 35 PSIG pressure inside it. If not, increase the pressure by adding refrigerant vapor to the system. **DO NOT EXCEED 150 PSI.**
5. Test each joint on both the low side and high side of the system and mark the leaks as they are found.
6. Repair the leak and test to be sure that all leaks have been stopped.
7. Install new drier on the system.
8. Evacuate the system.
9. Recharge the system with the proper amount of clean, dry refrigerant according to the name plate reading.

Procedure for Evacuating and Charging a System

Evacuation is a process used to remove air and moisture from the system. Evacuation is achieved by use of pumps specially designed for this purpose. A discarded compressor is not suitable. Never run a motor compressor while the system is evacuated. To do so may result in serious damage to the motor windings.

Purging a system will remove a good portion of the air and driers will remove a part of any moisture from the system, but only up to the capacity of the drier. Therefore, there are still contaminants left in the system and evacuation is the best means of being reasonably sure that the system is free from these contaminants.

The following procedure should be followed for proper evacuation:

1. Connect the gauge manifold to the system.
2. Purge all pressure from the refrigeration system by opening the system service valves and the gauge manifold hand valves.
3. Connect the center hose on the gauge manifold to the vacuum pump.
4. Start the vacuum pump and pump a vacuum of 29.9" or, preferably, 1,000 to 1,500 microns.

5. Close off the gauge manifold hand valves.
6. Stop the vacuum pump. DO NOT Stop pump before closing the gauge manifold hand valves. This is to prevent air from entering the system.
7. Disconnect the center hose of the gauge manifold from the vacuum pump and connect it to a cylinder containing the proper refrigerant.
8. Open the cylinder valve.
9. Loosen the center hose connection at the gauge manifold. Purge the hose for a few seconds; then tighten the connection.
10. Open the gauge manifold hand valves and admit refrigerant into the system. Note: The proper amount of refrigerant should be metered in—refer to nameplate.
11. Close the high side hand valve on the gauge manifold.
12. Start the unit and add the proper charge of refrigerant.
13. When completed, be sure to pinch off any high side tap lines and tighten all low side valve caps.

DEFECTIVE COMPRESSOR DIAGNOSIS

After many years of testing of the returned and replaced (warranty) compressors, our test results show that some compressors are not defective. In an effort to reduce this type of occurrence and, also, to supplement your information, we have listed a number of items that can cause the symptoms of a defective compressor as follows;

1. Compressor fails to start
 - a. fuse blown
 - b. control open
 - c. overload protector tripped
 - d. loose wire
2. Compressor will not start (hums and trips on the overload protector)
 - a. improperly wired
 - b. low voltage to unit
 - c. start relay open
3. Compressor will run, but remains on start winding
 - a. Improperly wired
 - b. low voltage to unit
 - c. defective overload protector
4. Compressor starts and runs, but short cycles
 - a. defective overload protector
 - b. low voltage to unit
 - c. suction pressure too low
 - d. suction pressure too high
 - e. erratic control
5. Suction line frosted or sweating
 - a. evaporator fan not running
 - b. overcharge of refrigerant
6. Head pressure too high
 - a. overcharge of refrigerant
 - b. dirty condenser
 - c. unit located in a too warm location
7. High suction pressure
 - a. evaporator iced up
 - b. overcharge of refrigerant
8. Low suction pressure
 - a. shortage of refrigerant

9. Start relay burned out
 - a. compressor short cycling
 - b. improperly wired relay
 - c. low voltage
 - d. excessive line voltage
10. Start relay contacts stuck
 - a. unit short cycles
11. Inside compartments of unit too warm
 - a. system short of refrigerant
 - b. thermostat set too low
 - c. dirty condenser
 - d. inoperative condenser fan
 - e. freezer fan inoperative
 - f. refrigerator fan inoperative
 - g. door switch inoperative
 - h. door gasket not sealing
 - i. evaporator coils iced over

In summary, the sealed system is a critical repair. Therefore, your procedures and reporting are imperative.

CONDENSATE LOOP LEAK REPAIR

Beginning with serial #227972, Sub-Zero utilized hot gas lines around the face of the freezer to prevent exterior cabinet condensation. Because the breakers are foamed in, it is difficult to access these lines should a leak be suspected. Great care should be taken in determining your leak location. All lines and joints should be carefully checked before suspecting the condensate loop.

Diagnosis #1

1. Using your electronic leak detector, trace the inside and outside edges of the breaker strips around the freezer. If a leak is detected pull the detector back slightly to be sure you are picking up a leak and not receiving a false reading from the refrigerant used in our foam insulation.
2. Concentrate on this area in an effort to isolate the leak location as close as possible before removing your breaker strips.
3. The breaker strips are foamed in and therefore must be broken out to access the freezer loop. Tear out the area of breaker where you were receiving your leak detection from. (it would be a good idea to have a new set of breaker strips for repair on hand).
4. Pull the loop out from the channel, pressurized the tubing and attempt to pin point the leak. Soap bubbles can be helpful in locating the exact spot of the leak.

5. After the leak has been located cut out the section of tubing where the leak was found. Insert a new piece of refrigeration copper and weld it in. Replace the loop back into the channel and replace any insulation broken away from the repair. Fiberglass insulation works well for this. Tape up the broken section of breaker strip and order the necessary replacement breakers.
6. Replace the drier filter, evacuate and recharge the system.

Diagnosis #2

1. If you are unable to locate and repair the leak, the loop will have to be bypassed. This will eliminate the freezer loop and drain pan loop. This can be accomplished by routing the tubing from the compressor into the condenser out of the condenser directly to the drier. Where you bypass the loop will depend on the type of system you are working on.
2. Refer to page 7-8 to order the proper supplemental frame heater kit.

M-Prefix Before Serial No.
Madison Equipment
P-Prefix Before Serial No.
Phoenix Equipment

SECTION 7
PRODUCT CHANGES
AND FIELD KITS

PRODUCT
CHANGES
AND
FIELD KITS

SUB-ZERO

QUICK REFERENCE SHEET ON SUB-ZERO PRODUCT CHANGES FROM 1976 TO 1985

<u>Serial #</u>	<u>Description</u>
196416	New gaskets & retainers. Gaskets prior to this serial number are no longer available
207047	New gasket seat hot gas loop on model 249FF and 244RFD
227972	Change to hot gas-heat transfer system
234227	New cabinet hinge support system began
253906	Channel kits installed at factory
254106	Air deflector kits installed at factory
321481	Change control from 3-01-234-0 to 3-01-234-1 for wider range
323831	Removed control well assembly - change back to old clamp (4-16-012-0)
326281	Change freezer fan blade from metal to plastic
332382	Add plastic sleeve to control (refrigerator) to get more range (except on the model 361RFD & 3211RFD after serial #M402308/P429835)
334334	Add polymer coating to drain pan tubing to prevent corrosion
338384	Add door closer kit to all model 201's (can be used on #234227-338384)
352047	Began using fixed switch depressor - no more adjustments
355297	New kickplate and drain pan assembly started
356747	Add door closer kit to all under counter models
366447	Change from metal to plastic drain pan on the models 201 & 215
391603	New door liner on the 244RFD - eliminates freezing conditions
393733	Change to new fan and light switch [two (2) S.P.S.T.]
M402308-P429835	Change in sizing of system on refrigerator side of model 3211RFD
403608	Add hook to shelf end caps to prevent breakage or falling out
431260	3211 Freezer using "0.1 oil cooled" compressor
509241	New updated system on the 22IM
551441	Started date coding on serial nameplate
551625	Delete hot melt adhesive from crisper glass assembly. Using silicone sealing
604591	Changed drain pan radius, less chance of cracking
655116	Energy changes in undercounter units
665000	Started using modular icemaker
700166	Condenser fan motor kit released (4-20-074-0)
716622	Introduced rounded rocker switches
M741373	Added rear wire to interior shelf on 249RP
749823	Added gravity door closer to both doors of 801RFD

M-Madison Production

P-Phoenix Production

22IM #272342 TO #509240

*Refer to next page for new style 22IM

The model 22IM, between serial #272342 to 509240 has the double evaporator system, with one evaporator under the icemaker assembly and the other located in the back of the compartment behind the duct cover. This unit makes ice at -10 degrees Fahrenheit and stores it at 20 degrees Fahrenheit.

Prior to serial #301252, this equipment used our control #3-01-238-0. After serial #301252, we utilize our control #3-01-244-0. At a #7 setting the cut-out temperature will be about -5 degrees Fahrenheit and the cut-in will be 5 degrees Fahrenheit. At the #1 setting, the cut-out will be 5 degrees Fahrenheit and the cut-in will be 15 degrees Fahrenheit.

Changes to be aware of relative to this equipment are listed as follows:

1. Charge - Use 6.5 oz. F-12 freon prior to serial #301252; 5.5 oz. F-12 between serial #301252 and #M423535, and 6.0 oz. F-12 starting with serial #M423535.
2. Run Time - 85% (while making ice).
3. Pressures - 4-5 PSIG cut-out; 34-35 PSIG cut-in.
4. Control Specifications - See paragraph above.
5. Compressor - Use #3-11-068-0.
6. Timer - Use #3-08-105-0 (twice daily defrost).
7. Time Delay Relay - Use #4-20-015-0 prior to serial #272342; use #3-06-012-0 after serial #272342.
8. Defrost Thermostat - Use #4-32-093-0.
9. Evaporator Fan Motor - Use #4-20-016-0 replacement kit.
10. Refrigerator Fan Blade - Use #3-15-021-0.

NOTE: The model 22IM, between serial #272342-509240, only produces ice on an off cycle on the control. During this time the compressor is off. When the icemaker starts its harvest cycle, the control bulb, which is clamped and is sensing the icemaker mold, detects the now elevating temperatures. When the cut-in temperature is reached, the control then closes. This is where the six minute delay comes in to make certain the icemaker has enough time to harvest and refill with water before energizing the relay and switching back to the compressor run. Please be advised that if the control is set to a higher, or colder, setting, less ice will be produced because of a longer run cycle. When turning the control lower, or warmer, more ice will be produced, but be aware this could offset the unit's temperatures.

22IM SYSTEM REDESIGN

Sub-Zero has redesigned the model #22IM undercounter automatic icemaker. These units are now in production and will be introduced to the field in the near future. The new design became effective as of Serial #509241.

We have incorporated a larger back wall evaporator while eliminating the secondary evaporator pass under the icemaker. This new coil is designed to run at a -20 degrees Fahrenheit coil temperature versus the old coil, which ran a -10 degrees Fahrenheit.

The refrigerant flow starts at the compressor to the condenser, around the hot gas gasket loop through the cap tube to the evaporator coil and returning to the compressor by way of the heat exchanger.

The air flow is consistent with our previous design. The inside air is pulled in from the bottom behind the evaporator cover and over the evaporator coil. The chilled air is then discharged over the top of the icemaker and is returned to cool the ice storage bucket to a 0 degrees Fahrenheit storage temperature.

The thermostat sensing is taking place at the top edge of the icemaker mold this senses a combination of cold temperature and air temperature. At a normal #4 control setting, the thermostat cuts out at -9 degrees Fahrenheit and cuts in at +6 degrees Fahrenheit with a cut-out pressure of 0# PSIG and a cut-in pressure of 12# PSIG.

We have changed the electrical system; the wiring diagram (see page) shows the addition of a drain tube and drain trough heater with both heaters remaining on for the duration of the defrost cycle. This diagram will also show the removal of the time delay relay. The relay split our wiring system between the compressor (run) and the icemaker (harvest). This allowed the icemaker to harvest only during the off cycle of the compressor with a six minute delay built into the relay so as to complete the harvest before the compressor could restart. With this new design, we have wired the icemaker direct. This allows the icemaker to harvest when the mold is satisfied.

CHANGES TO BE AWARE OF:

1. Drain Tube Heater - #3-01-332-0
2. Drain Trough Heater Assembly - #4-32-205-0
3. Defrost Heater Assembly - #4-32-195-0
4. Thermostat - #3-01-252-1 (cut-out -9 degrees F; cut-in +6 degrees F)
5. Pressures - 0# PSIG cut-out; 12# PSIG cut-in
6. Freezer Fan Motor - #4-20-016-0
7. Wire Basket Support (front) - #3-60-074-0
8. Door Assembly - #4-13-066-0
9. Door Liner - #0-88050-0
10. Freon Charge - 8.5oz (after serial #509241)
11. Heat Exchanger - #4-25-094-0
12. Accumulator - #3-01-112-0
13. Evaporator Coil - #3-13-019-0

NOTE: All parts not listed above will remain consistent with the previous design of the model 22IM.

DOOR STOP KIT

In certain applications, starting with serial #190441, it may be necessary to install one of our door stop kits, listed below, to prevent the doors from hitting fixtures in the home due to excessive door swing. The door stop kits are designed to rest the door at either 90 or 100 degrees from it's closed position. PLEASE NOTE: this doesn't correct a poor installation condition.

Top Mount
model 201R,F & 2011ICE
over & under refrig doors

4-20-033-1 right hand
4-20-033-2 left hand

Bottom Mount
model 361RFD & 3211RFD
over & under freezer doors

4-20-033-3 right hand
4-20-033-4 left hand

DOOR CLOSER FOR THE MODEL 201 SERIES

A gravity cam type door closing mechanism has been incorporated into all model 201R, 201FD, 201RIM and 2011ICE. We feel this closer will alleviate most of the problems associated with the bouncing of these large doors.

If you service a unit with the specific cam assembly broken or cracked you DO NOT have to order the complete door closer kit. The bottom door hinge cam (right or left swing) is identified by part #3-42-069-0. The bottom cabinet hinge is identified by part #3-42-068-1 for right hand swing and #3-42-068-2 for left hand swing. Please be aware that if the screw holding the cam assembly becomes loose, it may be necessary to use some loctite #371 (part #6-19-023-0) to assure a tight fit.

201 FIELD DOOR CLOSER KIT

Over the years, we've received complaints on these large doors bouncing open due to the size and the weight of the doors. Because of this, we have established a gravity type door closer kit, which can be used to eliminate this problem. This kit, #4-20-023-0 (right hand) and #4-20-024-0 (left hand) can be used between serial #234227 and #338384. These kits are not covered as a warranty item, but are considered a field accessory and can be purchased through your Parts Distributor. Beginning with serial #338385, this closer is a factory standard.

UNDERCOUNTER DOOR CLOSER KIT

Beginning with serial #356747, undercounter models 244RFD and the entire 249 series will have door closers. This door closer is similar to those used on built-in units, except that it is mounted on the side of the base.

For units prior to serial #356747 an "add-on" door closer kit is available through your Parts Distributor. These door closers are the same type which is now incorporated on the undercounter 244 and 249 models. There are two different kits available; part #4-20-026-0 for right hinged units and part #4-20-027-0 for left hinged units. Please be aware that the "add-on" door closer kits ARE NOT a warranty item, but an accessory. All units built after serial #356747 will have the closer installed.

UNDERCOUNTER DOOR SWING CHANGE KIT

With an increasing demand for left and right handed hinged products we have made both products available. Therefore, beginning with shipments dated after 5-18-84 the following swing change kits are available at a charge to the customer. To change the swing from right to a left swing order part #4-20-025-0; left to right swing order part #4-20-025-1. Also, if after the kit has been installed, a door adjustment is necessary, it IS NOT covered by the factory warranty.

2011 ICE DOOR ASSEMBLY

If the freezer door (part #4-18-073-0) needs replacement, it is NOT necessary to replace the complete icemaker sleeve assembly (part #4-20-038-0).

Please be aware that the rivits that connect the door hinge to the sleeve base are just for manufacturing purposes. If the rivits break loose, the door still remains intact and secured by the (2) two bottom screws (part #6-20-054-0) that hold the sleeve in place.

In the event that the door requires replacing (i.e. because of a cracked liner, warped door, etc), the defective door and hinge assembly must be removed by first removing the support screws and then pulling the rivits out. At that point, the new door and hinge assembly can be installed between the freezer sleeve and the interior base and secured by replacing the (2) two support screws.

ICE OR ICICLE FORMATION IN FREEZER DOORS

A situation could occur where air penetrates the seal between the foamed door slab and the back side of the gasket causing moisture to build up on the inside of the freezer door liner. The doors are manufactured in a way to prevent this by tightly securing the metal gasket retainers to the door with the gasket acting as the sealer.

If the door wasn't adequately sealed at the factory, the following is what to look for.

Situation: With freezer door open for an extended period of time water will drip from the bottom freezer door hinge.

Remedy: Remove door liner, gasket and retainers. Apply a bead of silicone approximately 3/16" diameter around the perimeter of the door shell. Also silicone around the bolts that secure the shelf ladders to the door liner. Reinstall gasket, liner and retainers making sure the seal is adequate between the back side of the gasket and the door shell (make sure you are sealed around the complete door).

SWEATING AROUND THE FREEZER DOORS

In the event there are periods of high humidity (exceeding 86% relative humidity), some moisture could appear. This condition will exist for short periods of time and will dissipate with a lower humidity. This particular occurrence is true with most types of refrigeration equipment. This condition can also be attributed to the door not sealing properly or some item in the unit propping the door open, keeping it from sealing properly. If the unit is installed in an area of continuous high humidity, please refer to page 7-8.

CRISPERS FALLING OFF TRACKS

If a situation occurs where the crispers have a tendency of falling off when removing them from the refrigerator section, a spacing or alignment problem may be prevalent. If this does occur, please note the amount of the crisper "flange" or edge that comes in contact with the crisper rollers on the slides. The flange should rest on the full width of the roller. If not, the crisper could fall off the slide roller when removing the crisper. A shim (part #3-21-001-0) can be put behind the slide roller to move the roller inward further. If this doesn't seem to be enough, shimming behind the slide and the tank wall can be done. Thin door spacers or washers can be used to accomplish this.

WATER IN BOTTOM OF REFRIGERATOR SECTION

If the presence of water occurs in the bottom of the refrigerator compartment, a careful examination of the drain trough assembly should be made. In some cases, the foam tape used to seal the drain trough to the refrigerator back wall may be ineffective and the defrost water will leak through the seal. If this occurs, we recommend that a small bead of silicone sealer be applied to the top edge of the drain trough, thereby eliminating any further chance of water leakage past this edge.

ICE FORMATION

On model 2711 and 2811 - if an icing condition occurs on the right hand side wall near the drain, possibly extending down the right hand side to the freezer slide assembly preventing the door from opening properly. Pull the cal rod heater down to make contact with the evaporator assembly and silicone around the evaporator cover at the drain end.

SHELF BAR CLIP KIT

4-20-036-0 (249R & 249RP prior to serial #M426734/P427635)

In the event a problem arises where the metal shelf bars on the door liners on the above listed units pulls off, you need to order part #4-20-036-0 to rectify the complaint.

WINE STORAGE CONTROL FOR MODEL 201R and 249RP

A wine storage control (part #3-01-229-0) is available for models 201R and 249RP. The control is a direct replacement for the existing control and will maintain a temperature of 55 degrees Fahrenheit. Please note that this is NOT a warranty procedure. This part can be ordered directly from your local Parts Distributor. (NOTE: this cannot be ordered with the equipment, it must be field installed)

STEP-DOWN TRANSFORMER

If there are requests for the application of our product with electrical requirements of 240V-100V - 50 cycle, we have available a GE step-down transformer. You will have to order part #3-06-009-0 for full size units or part #3-06-016-0 for undercounter units.

HARD START or LOW VOLTAGE CAPACITOR KIT

Because of many different locations and areas in which our equipment can be installed, the possibility of voltage variances can occur. In order to account for this variance, we have obtained a kit to aid in the starting of the compressor. This kit is available through your local Parts Distributor for use on 3-11-047-0 and 3-11-050-0 compressors **ONLY**. This kit should be used where the voltage is below 103.5V. The kit, 4-20-018-0, will consist of a start capacitor, capacitor cap, capacitor bracket and a start relay.

This kit IS NOT a warranty item and is not covered by our factory warranty. Please refer to your parts price book for the cost of this kit.

COMPRESSOR VIBRATION OR SHUDDERING AT SHUT-OFF

If a "shuddering or vibration" problem is evident during the time the compressor shuts off, we recommend the following:

1. Remove nut off clip from top of (4) compressor bolts.
2. Remove washer from compressor bolt.
3. Cut top "compressor neck" from the 3-15-017-0 grommet (*see note)
4. Lift compressor with existing grommet, off compressor bolt. Also, discard bolt sleeve.
5. Position grommet (with neck off) upside down over base bolt.
6. Replace existing grommet back onto base bolt with compressor flange inserted into "neck".
7. Do NOT replace nut or clip; do NOT replace washer; do NOT replace sleeve.
8. Install safety clip over threaded bolt; these can be put on by hand and pushed to the first or second thread (3-45-043-0).
9. Check all adjacent tubing to make sure there are no "rattles" or "vibrations".

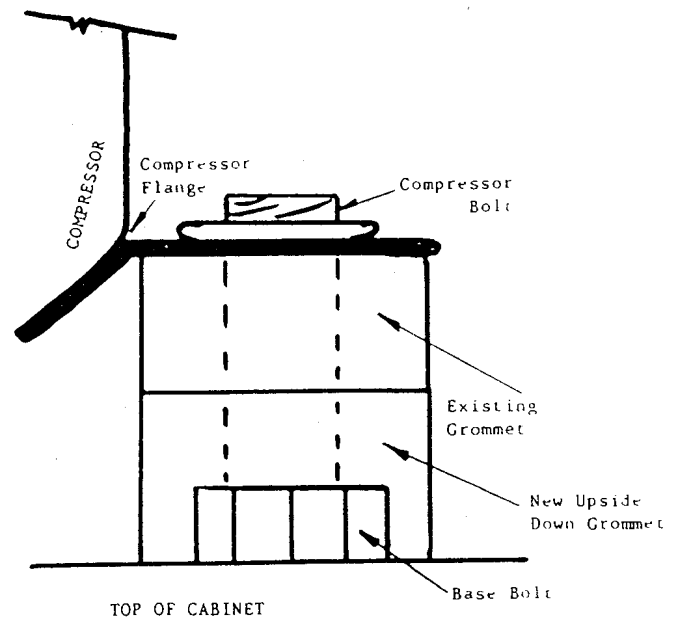

#3-75-179-0 (4-2-85)

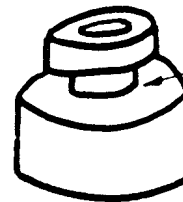

Per Item #3 Cut Top "Compressor Neck" Here

NOTE: ONLY PARTS NECESSARY ARE (4) 3-15-017-0 GROMMETS & (4) #3-45-043-0 RETAINER CLIPS

REFRIGERATOR EVAPORATOR/HEAT EXCHANGER KIT (4-20-032-0)

On our Model 3211RFD, between serial #299658 and M402308/P429835, certain situations (i.e. warm ambient, high humidity, high useage etc) many exist where the sizing of the refrigerator section evaporator may become marginal. This condition which resulted in completely frosted coils and elevated temperatures can be corrected by ordering part #4-20-032-0.

CONDENSER FAN OPERATION

Prior to the hot gas design change, beginning with serial #227972, our units were designed to run the condenser fan 100% to keep both the compressor and condenser cooler, thereby, more efficient. However, associated with the hot gas system was a change in the compressor and condenser size allowing us to cycle the condenser fan with the compressor on our single compressor units- 201FD, 201R, 211, 241, 244, 245, 249R, 249RP, 249FF, 251, 361 and 801. The condenser fan still runs 100% of the time on our dual compressor models- 2011ICE, 2411, 2511, 2711, 2811 and 3211.

SUPPLEMENTAL HEATER KIT for units starting with serial #227972

Cold temperatures, or refrigeration, and high humidity have never been a good combination. When a refrigeration system is designed, especially when great temperature differences are evident, heat must be applied to those surfaces to suppress any possible chance of sweating. Most refrigeration manufacturers in the past have used electric mullion heaters, door heaters or epoxy heaters to raise the surface temperatures of these areas.

Our design criteria was set at approximately 85% relative humidity and felt this would combat the possibility of sweating around the freezer doors. During periods of unusually high humidity, there were times the heat produced by the hot gas system would not handle the freezer doors and moisture would appear. This situation is very limited and only should appear when the humidity exceeds the 85% mark. This, of course, will happen on all refrigerators under these conditions.

For this reason, we are supplying a supplemental heater kit, which consists of an electric heat wire that lays on top of the existing hot gas tubing which spans the freezer perimeter. This should handle any moisture which could appear during this very extreme humidity period. Please be aware this will be in addition to the existing hot gas system and is being added to dry the freezer door edges. If this repair is needed please order by model and serial number one of the kits listed below.

<u>Model #</u>	<u>Kit #</u>	<u>Model #</u>	<u>Kit #</u>
201FD.....	4-20-014-1	2511RFD.....	4-20-014-4
211RFD.....	4-20-014-2	361RFD.....	4-20-014-5
241RFD.....	4-20-014-3	3211RFD.....	4-20-014-6
251RFD.....	4-20-014-4		

NOTE: Please refer below if the hot gas loop around the freezer frame needs to be by-passed.

200/300 SERIES FREEZER FRAME - DRAIN HEATER KITS starting with serial #227972

On occasion leaks can develop on the hot gas loop (frame heater) around the freezer section. In certain situations it becomes necessary to by-pass the freezer frame heater and condensate loop over the drain pan area. If this repair is needed please order one of the following kits listed below.

<u>Model #</u>	<u>Kit #</u>	<u>Model #</u>	<u>Kit #</u>
201FD.....	4-20-100-1	361RFD.....	4-20-100-5
211RFD.....	4-20-100-2	3211RFD.....	4-20-100-6
241RFD.....	4-20-100-3	2711RFD.....	4-20-103-0
251,2511RFD....	4-20-100-4	2811RFD.....	4-20-104-0

NOTE: These kits are utilized **ONLY** if the hot gas loop is being by-passed.

LIGHT SWITCH KIT

(replaced 3-06-006-0 switch)

Starting with serial #M393733/P397233 on models 211RFD, 241RFD, 251RFD and 2511RFD refrigerators ONLY and 361RFD, 3211RFD refrigerators AND freezers, the double pole-double throw rocker switch (3-06-006-0) is replaced by the single pole-single throw rocker switch (3-06-014-0).

If switch replacement is necessary for the above listed models with a serial number prior to #M393733/P397233 you will need to order part #4-20-034-0.

SURROUNDING AMBIENT TEMPERATURES

Over the past year or so, we've noticed an ever increasing number of Sub-Zero's being installed in locations not normally associated with our products. As our sales have increased so have these types of installations. We're finding our equipment in residences that are not used on a full-time basis.

For different reasons, many people dial the thermostat down when the home isn't occupied. In some instances, we're finding that the temperatures are being set as low as 52-55 degrees Fahrenheit. These lower room ambients can be a problem with respect to the operation of certain Sub-Zero models.

Through our service records and testing by our Engineering Department, it was noted that the ambient room temperatures must be kept at a minimum of 57 degrees Fahrenheit for the equipment to operate properly. (This only concerns our models 211RFD, 241RFD, 251RFD and 361RFD) To elaborate on this, the four models listed have one compressor with two areas to cool (refrigerator and freezer). The complete unit is controlled through the refrigerator control, which is set at the factory at 38-40 degrees Fahrenheit. With the ambient room temperature at 57 degrees Fahrenheit, there isn't enough differential to activate the control on a regular basis. The outcome is a higher than the normal 0 degree Fahrenheit temperature in the freezer compartment with thawing occurring.

You can see how this can instigate a service call plus an irate customer, especially when no mechanical problem can be found. Of course, this below 57 degree Fahrenheit temperature would have to be for an extended time, such as three days or more. One night would not affect the equipment. In essence, we are, therefore, recommending that these four units (211RFD, 241RFD, 251RFD and 361RFD) not be used under these circumstances.

SHUTTING EQUIPMENT DOWN

Our product usage is becoming more versatile as our sales continue to grow. Some of our equipment is located in winter homes, summer homes, yachts and condo projects. Due to this wide array of usage, a potential problem could exist primarily when the equipment is used on a limited or short time basis.

Each time the equipment is started and the compressor runs, moisture collects in the inside of the refrigerator and freezer. When the equipment is turned off, moisture and water remain in the unit.

This is where the problems begin; the confined moisture has nowhere to go, so it attacks the shelves, the screws, the fan motor and even begins to discolor the aluminum parts. This process becomes worse when the equipment is located near salt water. The salt becomes airborne, gets inside the box and accelerates the corrosion process. This, of course, can and will occur on our units and, most likely, all other brands, if certain precautions are not taken.

The control(s) should be turned OFF so the compressor(s) cannot run. Wipe out the interior of the unit and keep the door(s) open.

REPAIRING AND TOUCHING UP PAINT SCRATCHES

There are times when the interior of the unit gets scratched due to a shelf coming loose, an installer not properly assembling the unit or the customer damaging the interior when in use. If this occurs, the proper method for repair is listed below. Please keep in mind that if the surface is dented, it will be necessary to fill that dent with an epoxy or body filler prior to this procedure. This can only be used when the surface paint has either pulled off, been scratched or bruised.

1. Sand the area needing the repair; rub only the damaged area. Sand ONLY to the paint where the scratch is removed. Deep sanding will remove the paintlok surface in the metal. Finish sanding operation with a fine sand paper to assure smoothness.
2. Clean sanded area using a clean rag; no cleaning materials are to be used.
3. Begin putting on VERY THIN layers of W28950 white spray paint #6-17-007-0*. NOTE: you can put up to (8) eight coats of paint depending on the original paint thickness already on the interior; remember, only a "fog" coat at a time. Wait approximately (4) four minutes between each coat.
4. After the painting is complete, wait (3) three hours before polishing. To speed the process, a hair dryer on LOW or a light bulb can be used to help cure the area and reduce the time to (2) two hours.
5. After the paint has cured, as mentioned in step #4, begin to polish with DuPont #7 polishing compound (available at a hardware store). Lightly apply compound to surface. Apply to complete area painted.
6. Lastly, apply a wax, such as Turtle Wax, to the area painted. This will aid in blending to surrounding surfaces.

*The paint is available in 4.5oz spray bombs from your parts distributor

M-Prefix Before Serial No.
Madison Equipment
P-Prefix Before Serial No.
Phoenix Equipment

SECTION 8
SERVICE DIAGNOSIS
CHECK LIST

SERVICE
DIAGNOSIS
CHECK LIST

SUB-ZERO

SERVICE DIAGNOSIS CHECKLIST

<u>Condition</u>	<u>Possible Failure</u>	<u>Corrective Action</u>
Compressor fails to start	1. power failure	1. contact power company
	2. Fuse blown	2. replace or reset
	3. burned out compressor motor	3. replace compressor
	4. bad start relay	4. replace start relay
	5. control circuit open <ul style="list-style-type: none"> a. overload protector tripped b. control set too high c. defective control d. loose wire 	5. locate cause & repair <ul style="list-style-type: none"> a. check overload b. reset control c. replace control d. repair wiring
Compressor will not start (hums & trips overload protector)	1. low voltage to unit	1. determine reason & correct
	2. bad start capacitor	2. replace
	3. start relay open	3. replace
	4. burned out compressor	4. replace
Compressor starts & runs (but short cycles)	1. defective overload	1. replace overload
	2. low voltage to unit	2. determine reason & repair
	3. high discharge pressure	3. purge to correct pressure
	4. open or shorted motor	4. replace compressor
	5. compressor too hot	5. adjust to proper charge
	6. condenser too hot	6. clean condenser
	7. erratic thermostat	7. replace thermostat
Unit Operates Excessively	1. short of refrigerant	1. repair leak & recharge
	2. thermostat contact stuck closed	2. replace thermostat
	3. separated heat exchanger	3. repair heat exchanger
	4. evaporator coil iced	4. defrost & check
	5. restriction in refrigerant system	5. locate & remove
	6. dirty condenser	6. clean condenser
	7. restricted air flow over evaporator	7. locate cause & repair
	8. inefficient compressor	8. check & repair
Compressor Noisy	1. tubing rattle	1. reroute tubing
	2. mounting loose	2. repair mounting
	3. refrigerant flooding compressor	3. adjust charge
	4. internal parts broken to compressor	4. replace compressor
High temps in storage area	1. control set too low	1. adjust control
	2. insufficient air circulation	2. check fan & switch
	3. lack of refrigerant	3. check pressure & charge
	4. evaporator iced up	4. defrost coil
	5. air leak at door seal	5. adjust door & gasket

<u>Condition</u>	<u>Possible Failure</u>	<u>Corrective Action</u>
Suction line frosted or sweating	<ol style="list-style-type: none"> 1. evaporator fan not running 2. overcharge of refrigerant 	<ol style="list-style-type: none"> 1. check fan & switch 2. adjust charge
High head pressures	<ol style="list-style-type: none"> 1. overcharge of refrigerant 2. air in system 3. dirty condenser 	<ol style="list-style-type: none"> 1. purge overcharge 2. purge air 3. clean condenser
Low head pressures	<ol style="list-style-type: none"> 1. shortage of refrigerant 2. cold unit location 3. inefficient compressor valves 	<ol style="list-style-type: none"> 1. repair leak & recharge 2. provide warm condenser air 3. replace compressor
high suction pressure	<ol style="list-style-type: none"> 1. evaporator overloaded 2. overcharge of refrigerant 3. inefficient compressor valves 	<ol style="list-style-type: none"> 1. defrost & check for problem 2. adjust to proper charge 3. replace compressor
Low suction pressure	<ol style="list-style-type: none"> 1. shortage of refrigerant 2. evaporator underloaded 3. drier restricted 	<ol style="list-style-type: none"> 1. repair leak & recharge 2. clean & defrost evaporator 3. clean & replace drier
Starter relay burned out	<ol style="list-style-type: none"> 1. compressor short cycling 2. wrong relay 3. excessive line voltage 	<ol style="list-style-type: none"> 1. replace relay 2. check & replace 3. reduce to a maximum of 10% over motor rating
Evaporator freezes but defrosts while unit is running	<ol style="list-style-type: none"> 1. moisture in system 	<ol style="list-style-type: none"> 1. purge-evacuate-replace drier & recharge
Evaporator coil iced over (refrigerator)	<ol style="list-style-type: none"> 1. defective control 2. air leak at door gasket 3. improper air circulation 	<ol style="list-style-type: none"> 1. replace control 2. locate & adjust 3. adjust fan blade position
Evaporator coil iced over (freezer)	<ol style="list-style-type: none"> 1. defrost timer bad 2. defrost timer improperly wired 3. defective defrost thermostat 4. improperly installed defrost thermostat 5. defective defrost heater 6. loose wire to defrost heater 7. air leak at freezer door 8. drain tube heater burned out 9. freezer drain clogged 	<ol style="list-style-type: none"> 1. replace timer 2. rewire timer 3. replace defrost thermostat 4. relocate element 5. replace heater 6. locate & repair 7. adjust door 8. replace drain heater 9. clean drain
Water collects in bottom of refrigerator	<ol style="list-style-type: none"> 1. drain clogged 2. drain trough improperly sealed 3. drain tube out of position 4. evaporator coil out of position 5. door gasket not sealing properly 	<ol style="list-style-type: none"> 1. clean drain 2. reseal drain trough 3. repair drain tube 4. adjust evaporator coil 5. adjust door or replace gasket

<u>Condition</u>	<u>Possible Failure</u>	<u>Corrective Action</u>
Condensation on outside of cabinet	<ol style="list-style-type: none"> 1. door gasket leaking 2. mullion heater burned out 3. hot gas defrost inefficient 4. abnormally high humidity 	<ol style="list-style-type: none"> 1. adjust door or replace gasket 2. replace mullion heater 3. adjust charge or check for leak (add thermomastic) 4. none (explain reason to customer—could sweat above 86% rel humidity)
Water or ice collects in bottom of freezer	<ol style="list-style-type: none"> 1. drain tube frozen 2. drain tube cut 3. evaporator cover plate leaking 4. wiring & tubing air leak 5. automatic icemaker overfills 	<ol style="list-style-type: none"> 1. defrost & repair heater 2. repair drain tube 3. repair leak 4. reseal openings 5. adjust water level
Refrigerator too warm	<ol style="list-style-type: none"> 1. poor air circulation 2. defective or erratic fan switch 3. thermostat set too low 4. defective control 5. loose clamp to control (short cycling) 6. bad door seal 7. system restriction 	<ol style="list-style-type: none"> 1. adjust fan blade 2. replace switch 3. adjust control 4. replace control 5. provide good contact 6. repair or replace 7. locate & repair

M-Prefix Before Serial No.
Madison Equipment
P-Prefix Before Serial No.
Phoenix Equipment

SECTION 9 **WIRING DIAGRAMS**

WIRING DIAGRAMS

SUB-ZERO

361
WIRING DIAGRAM
 AFTER SERIAL NO. M393733/P397233

SCHEMATIC

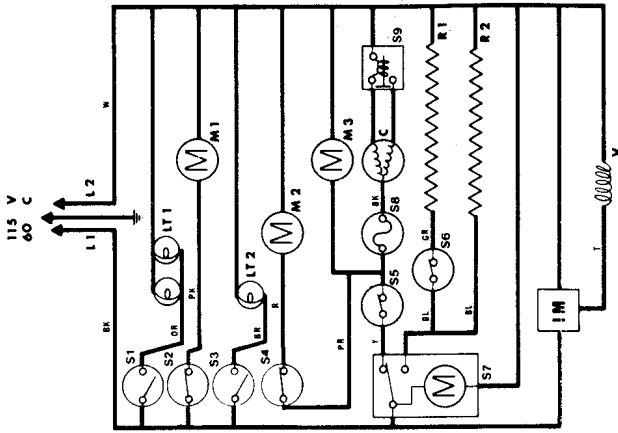

LEGEND

- | | |
|-----|-------------------------------------|
| C | - Compressor |
| IM | - Icemaker |
| L1 | - Line 1 |
| L2 | - Line 2 |
| LT1 | - Refrigerator Light |
| LT2 | - Freezer Light |
| M1 | - Refrigerator Fan Motor |
| M2 | - Freezer Fan Motor |
| M3 | - Condenser Fan Motor |
| R1 | - Defrost Heater |
| R2 | - Drain Tube Heater |
| S1 | - Refrigerator Door Switch - Light |
| S2 | - Refrigerator Door Switch - Fan |
| S3 | - Freezer Door Switch - Light |
| S4 | - Freezer Door Switch - Fan |
| S5 | - Refrigerator Thermostatic Control |
| S6 | - Defrost Terminator |
| S7 | - Defrost Timer |
| S8 | - Compressor Overload Protector |
| S9 | - Compressor Starting Relay |
| V | - Icemaker Water Valve |
-
- | | |
|----|----------|
| BK | - Black |
| BL | - Blue |
| BR | - Brown |
| GR | - Gray |
| GN | - Green |
| OR | - Orange |
| PK | - Pink |
| PR | - Purple |
| R | - Red |
| T | - Tan |
| W | - White |
| Y | - Yellow |
- 361
3-75-066-1

WIRING DIAGRAM

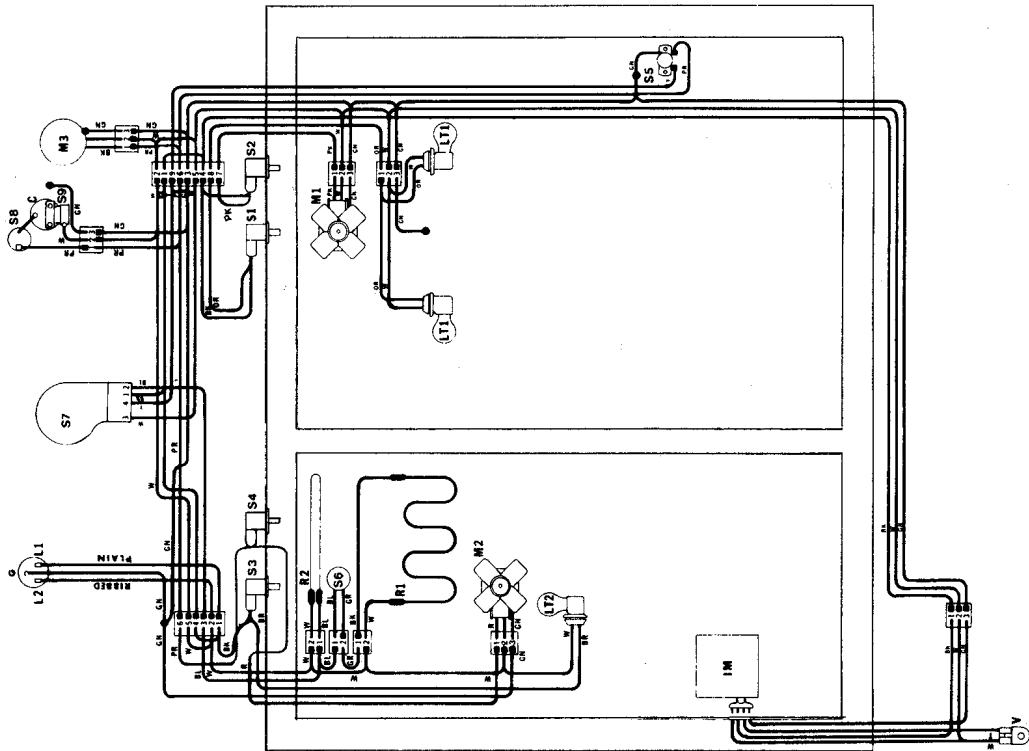

361RFD WIRING DIAGRAM AFTER SERIAL NO. 227972 TO M393733/P397233

SCHEMATIC

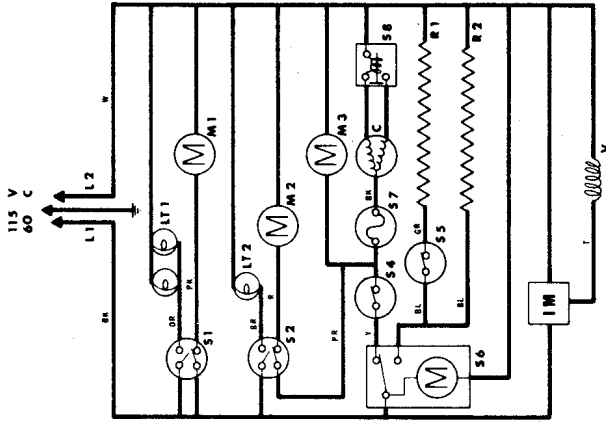

LEGEND

- | | | | |
|----|-----------------------------------|----|----------|
| C | - Compressor | BK | - Black |
| IM | - Icemaker | BL | - Blue |
| L1 | - Line 1 | BR | - Brown |
| L2 | - Line 2 | GR | - Gray |
| L3 | - Line 3 | GN | - Green |
| M1 | - Refrigerator fan motor | OR | - Orange |
| M2 | - Freezer fan motor | PK | - Pink |
| M3 | - Condenser fan motor | PR | - Purple |
| R1 | - Defrost heater | R | - Red |
| R2 | - Drain tube heater | T | - Tan |
| S1 | - Refrigerator door switch | W | - White |
| S2 | - Freezer door switch | Y | - Yellow |
| S3 | - Refrigerator thermostat control | | |
| S4 | - Defrost terminator | | |
| S5 | - Defrost timer | | |
| S6 | - Compressor overload protector | | |
| S7 | - Compressor starting relay | | |
| S8 | - Icemaker water valve | | |
| V | | | |
- 361 RFD** 3-75-066-0 r. A

WIRING DIAGRAM

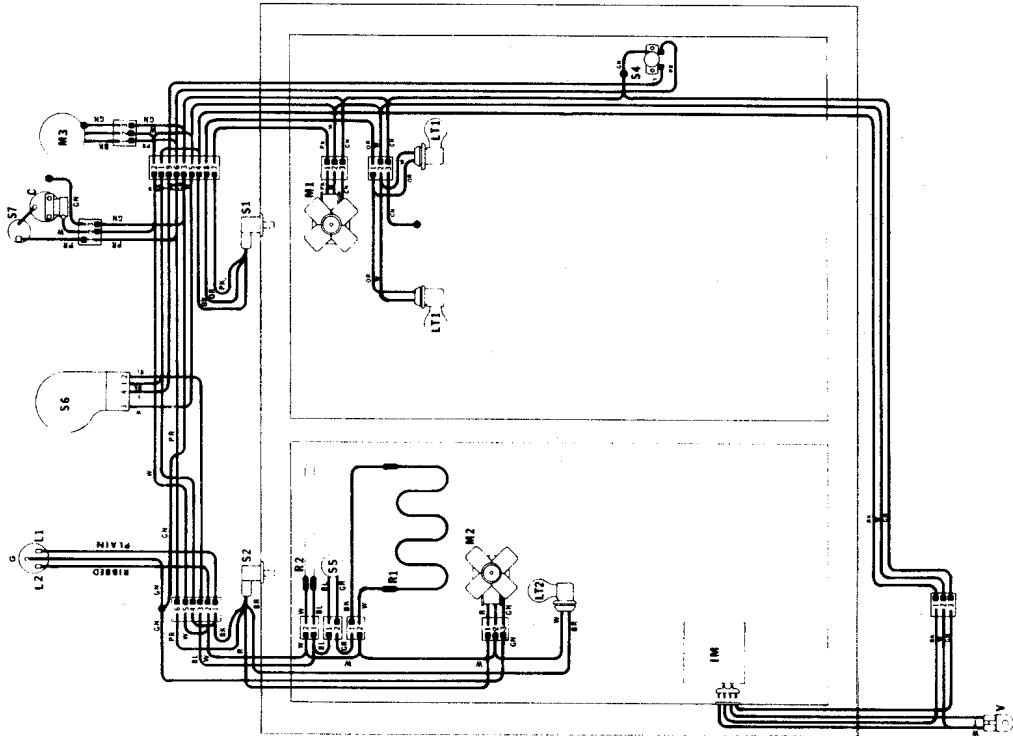

**361RFD
WIRING DIAGRAM
PRIOR TO SERIAL NO. 227972**

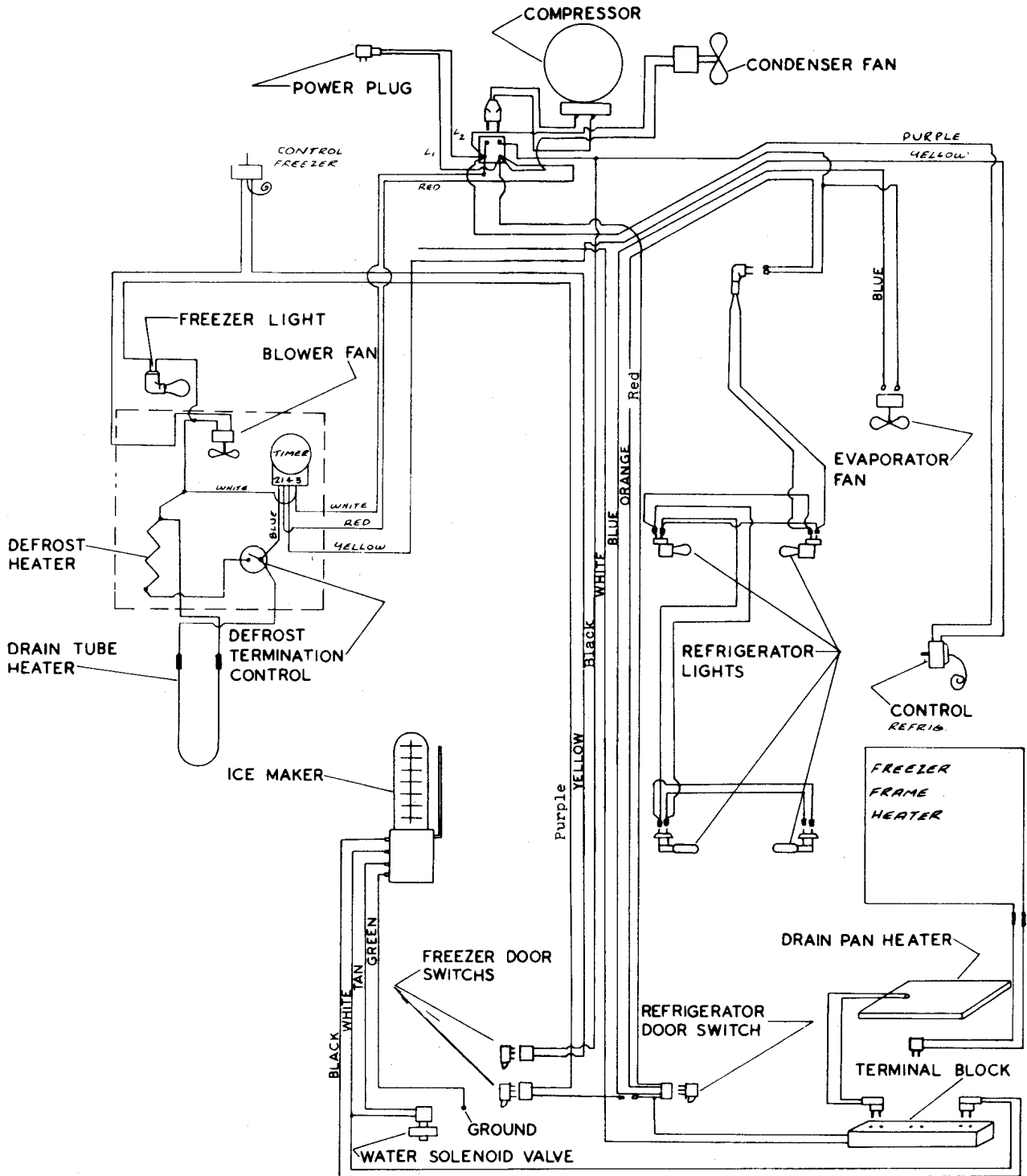

3211

WIRING DIAGRAM

AFTER SERIAL NO. M393733/P397233

SCHEMATIC

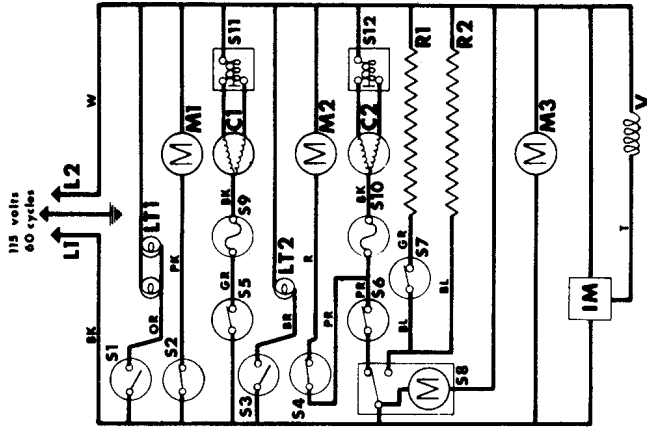

LEGEND

- BK - Black
 - BL - Blue
 - BR - Brown
 - GR - Green
 - OR - Orange
 - PK - Pink
 - PR - Purple
 - RE - Red
 - TN - Tan
 - W - White
 - Y - Yellow
- C1 - Refrigerator Compressor
 - C2 - Freezer Compressor
 - IM - Icemaker
 - L1 - Line 1
 - L2 - Line 2
 - LT1 - Refrigerator Light
 - LT2 - Freezer Light
 - M1 - Refrigerator Fan Motor
 - M2 - Freezer Fan Motor
 - M3 - Condenser Fan Motor
 - R1 - Defrost Heater
 - R2 - Drain Tube Heater
 - S1 - Refrigerator Door Switch - Light
 - S2 - Refrigerator Door Switch - Fan
 - S3 - Freezer Door Switch - Light
 - S4 - Freezer Door Switch - Fan
 - S5 - Refrigerator Fan
 - S6 - Refrigerator Thermostatic Control
 - S7 - Freezer Thermostatic Control
 - S8 - Defrost Timer
 - S9 - Refrigerator Overload Protector
 - S10 - Freezer Overload Protector
 - S11 - Refrigerator Compressor Starting Relay
 - S12 - Freezer Compressor Starting Relay
 - V - Icemaker Water Valve
- 3211 3-75-068-1

WIRING DIAGRAM

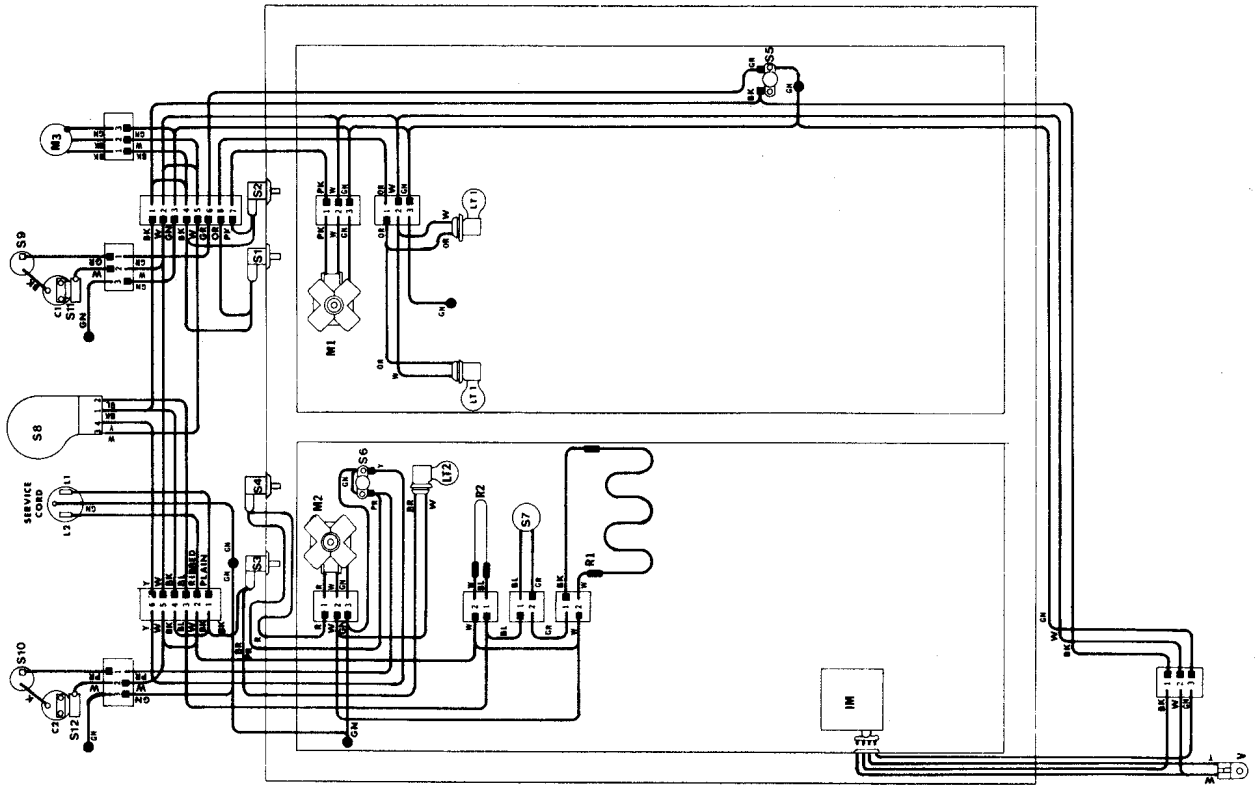

3211RFD WIRING DIAGRAM AFTER SERIAL NO. 227972 TO M393733/P397233

SCHEMATIC

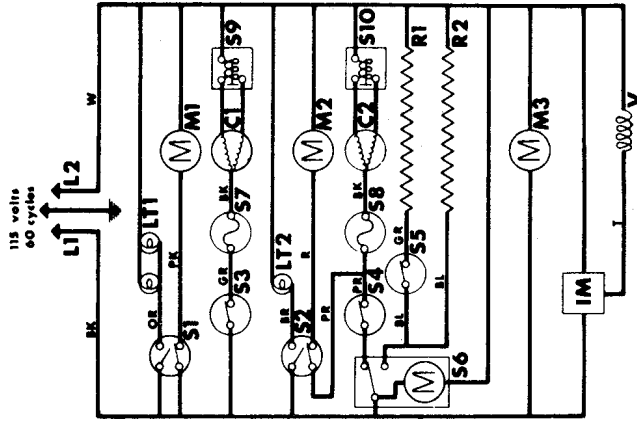

LEGEND

- C1 - Refrigerator compressor
- C2 - Freezer compressor
- IM - Icemaker
- L1 - Line 1
- L2 - Line 2
- LT1 - Refrigerator light
- LT2 - Freezer light
- M1 - Refrigerator fan motor
- M2 - Freezer fan motor
- M3 - Condenser fan motor
- R1 - Defrost heater
- R2 - Drain tube heater
- S1 - Refrigerator door switch
- S2 - Freezer door switch
- S3 - Refrigerator thermostat control
- S4 - Freezer thermostat control
- S5 - Defrost terminator
- S6 - Defrost timer
- S7 - Refrigerator overload protector
- S8 - Freezer overload protector
- S9 - Refrigerator compressor starting relay
- S10 - Icemaker water valve
- V -

3211 RFD
3-75-068-0 r.A

WIRING DIAGRAM

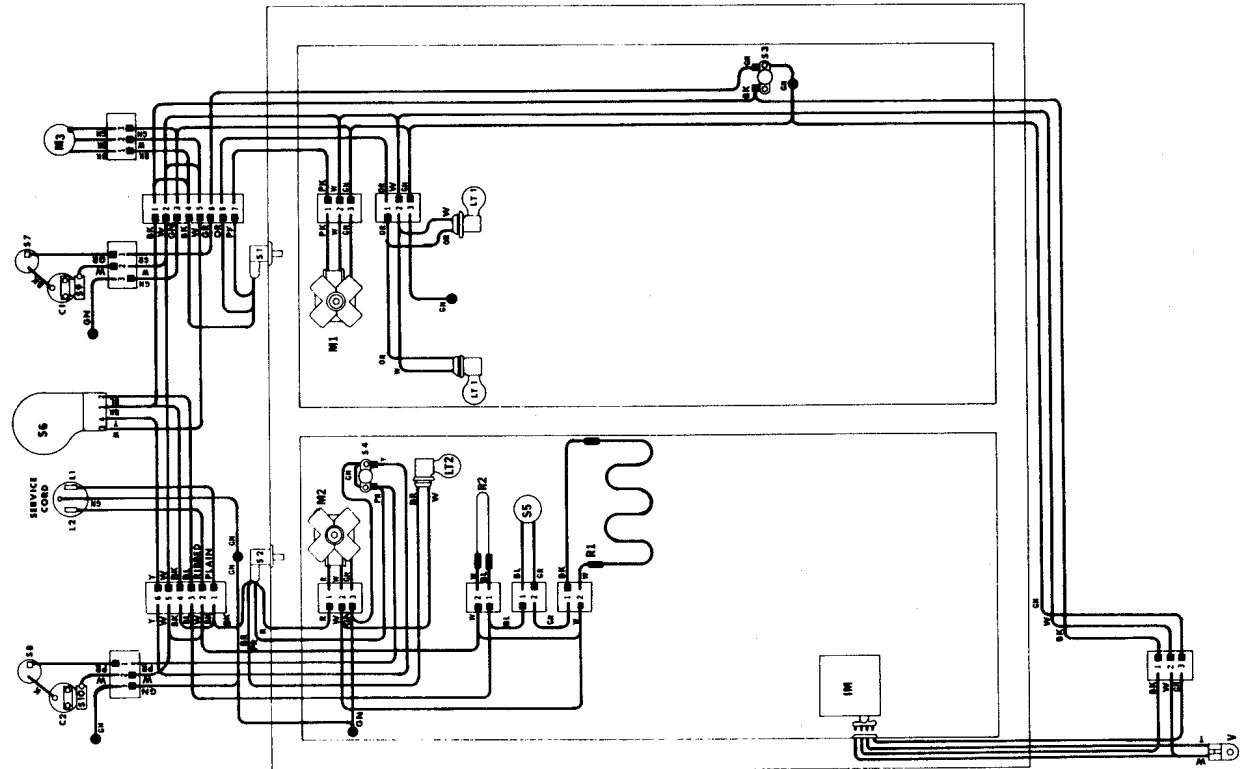

3211RFD WIRING DIAGRAM PRIOR TO SERIAL NO. 227972

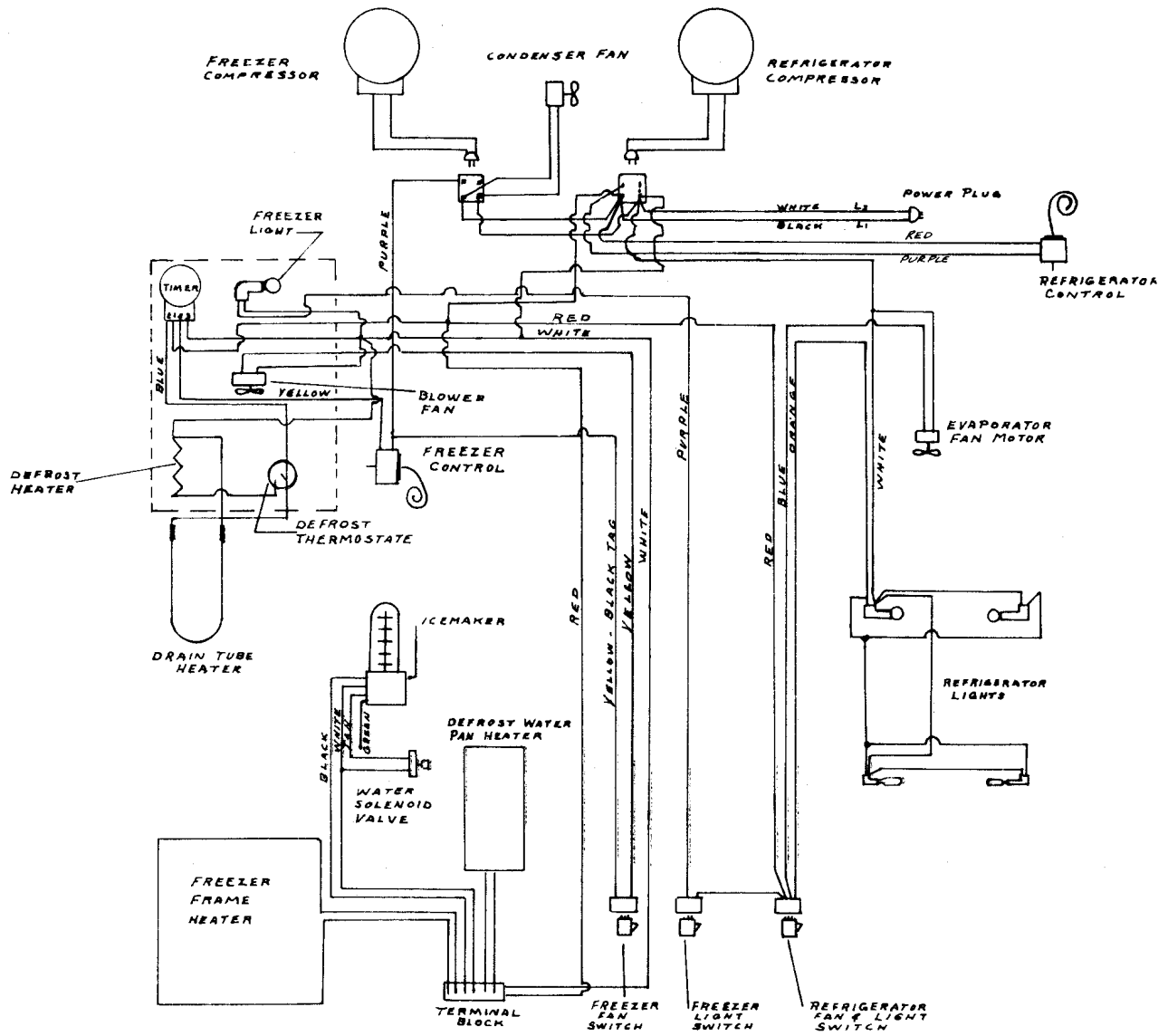

211 - 241 - 251
WIRING DIAGRAM
 AFTER SERIAL NO. M393733/P397233

SCHEMATIC

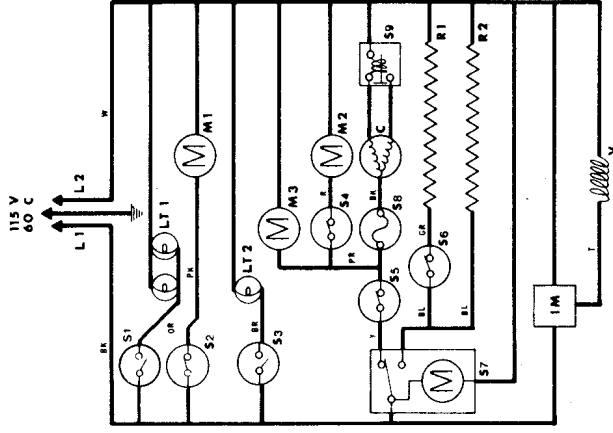

LEGEND

- | | | | | |
|-----|-------------------------------------|-----|-----|-----|
| C | - Compressor | 211 | 241 | 251 |
| IM | - Ice-maker | | | |
| L1 | - Line 1 | | | |
| L2 | - Line 2 | | | |
| LT1 | - Refrigerator Light | | | |
| M1 | - Refrigerator Fan Motor | | | |
| M2 | - Freezer Fan Motor | | | |
| M3 | - Condenser Fan Motor | | | |
| R1 | - Defrost Heater | | | |
| R2 | - Defrost Thermostat | | | |
| S1 | - Refrigerator Door Switch - Light | | | |
| S2 | - Refrigerator Door Switch - Fan | | | |
| S3 | - Freezer Door Switch - Light | | | |
| S4 | - Freezer Door Switch - Fan | | | |
| S5 | - Refrigerator Thermostatic Control | | | |
| S6 | - Defrost Timer | | | |
| S7 | - Compressor Overload Protector | | | |
| S8 | - Compressor Starting Relay | | | |
| V | - Ice-maker Water Valve | | | |

WIRING DIAGRAM

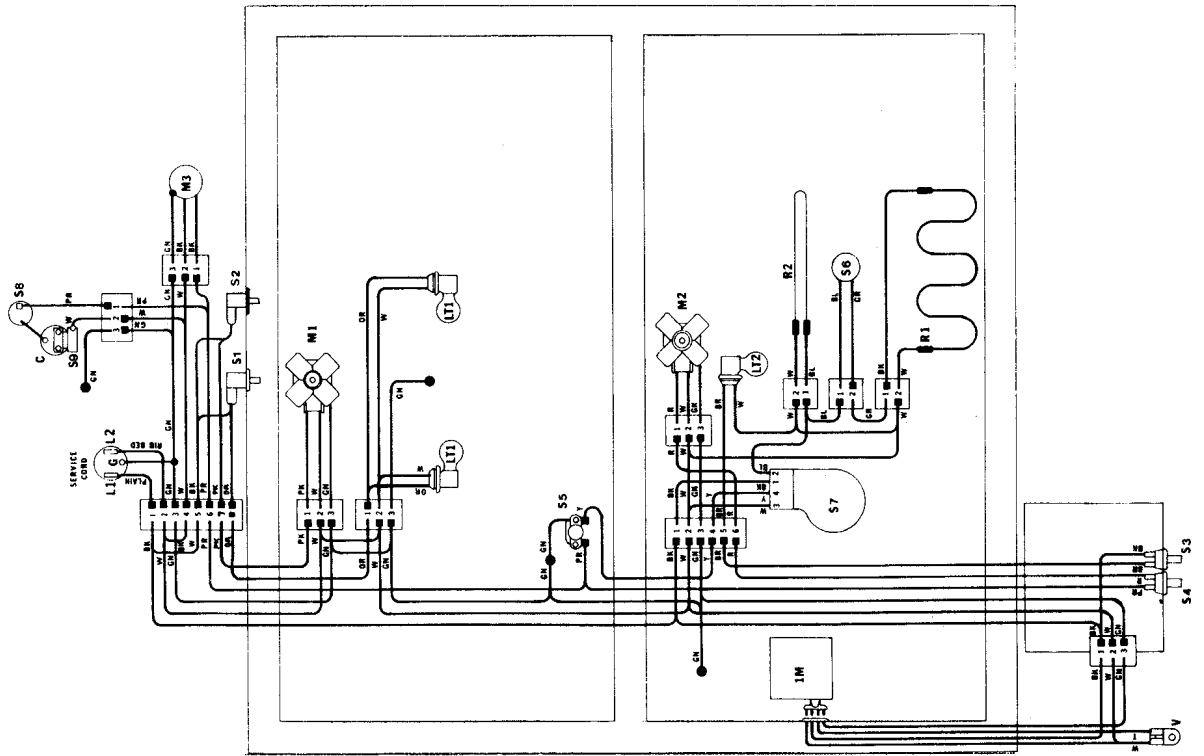

**211RFD · 241RFD · 251RFD
WIRING DIAGRAM
AFTER SERIAL NO. 227972 TO M393733/P397233**

SCHEMATIC

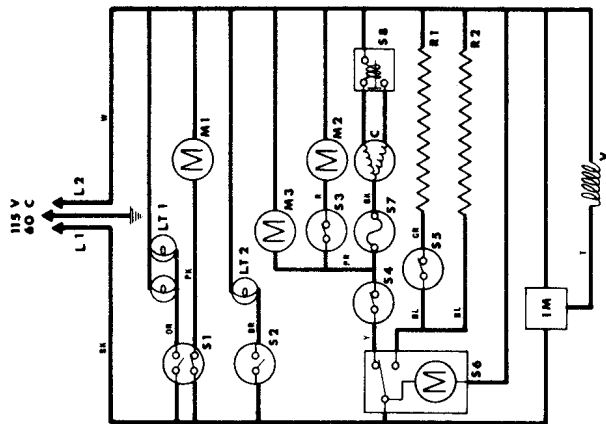

LEGEND

- | | | | |
|-----|-----------------------------------|-----|----------|
| C | - Compressor | BK | - Black |
| IM | - Icemaker | BL | - Blue |
| L1 | - Line 1 | BR | - Brown |
| L2 | - Line 2 | GR | - Gray |
| LT1 | - Refrigerator light | GRN | - Green |
| LT2 | - Freezer light | OR | - Orange |
| M1 | - Refrigerator fan motor | PK | - Pink |
| M2 | - Freezer fan motor | PR | - Purple |
| M3 | - Condenser fan motor | R | - Red |
| R1 | - Drain tube heater | T | - Tan |
| R2 | - Refrigerator door switch | W | - White |
| R3 | - Freezer door switch - light | Y | - Yellow |
| S1 | - Freezer door switch - fan | | |
| S2 | - Refrigerator thermostat control | | |
| S3 | - Defrost terminator | | |
| S4 | - Compressor overload protector | | |
| S5 | - Compressor starting relay | | |
| S6 | - Icemaker water valve | | |
| S7 | | | |
| S8 | | | |
| V | | | |

211RFD, 241RFD, 251RFD 3-75-064-O R. A

WIRING DIAGRAM

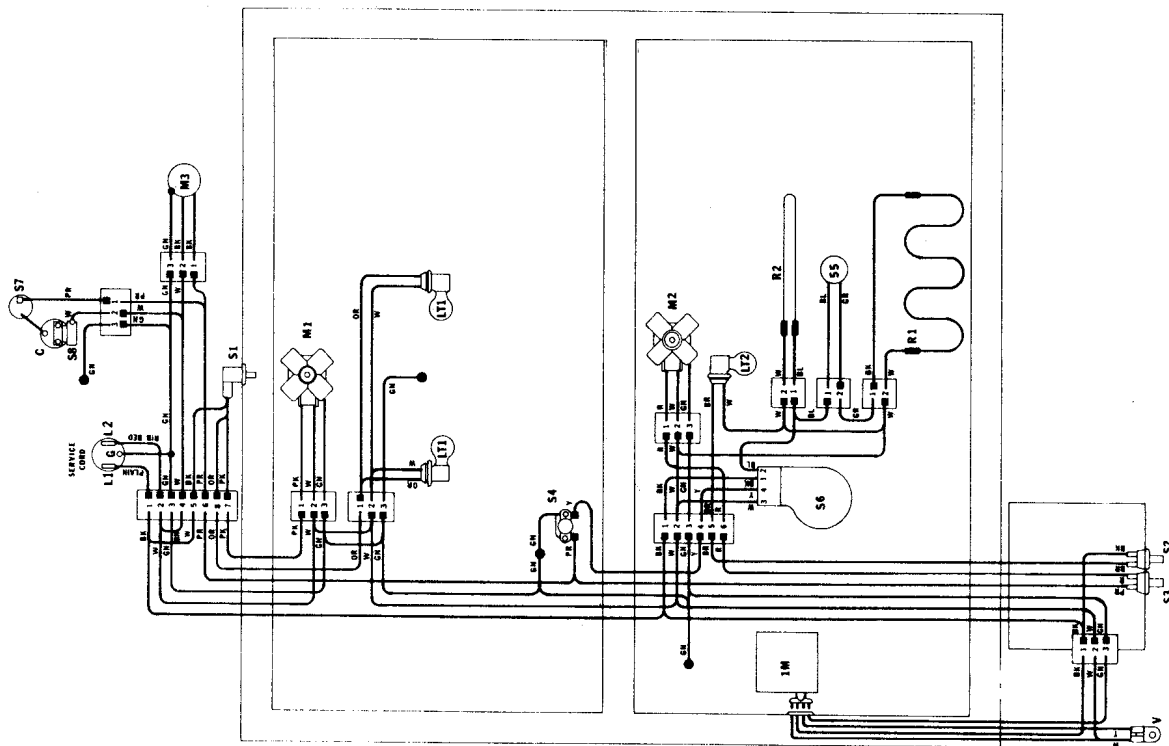

**241RFD - 251RFD - 211RFD
WIRING DIAGRAM
PRIOR TO SERIAL NO. 227972**

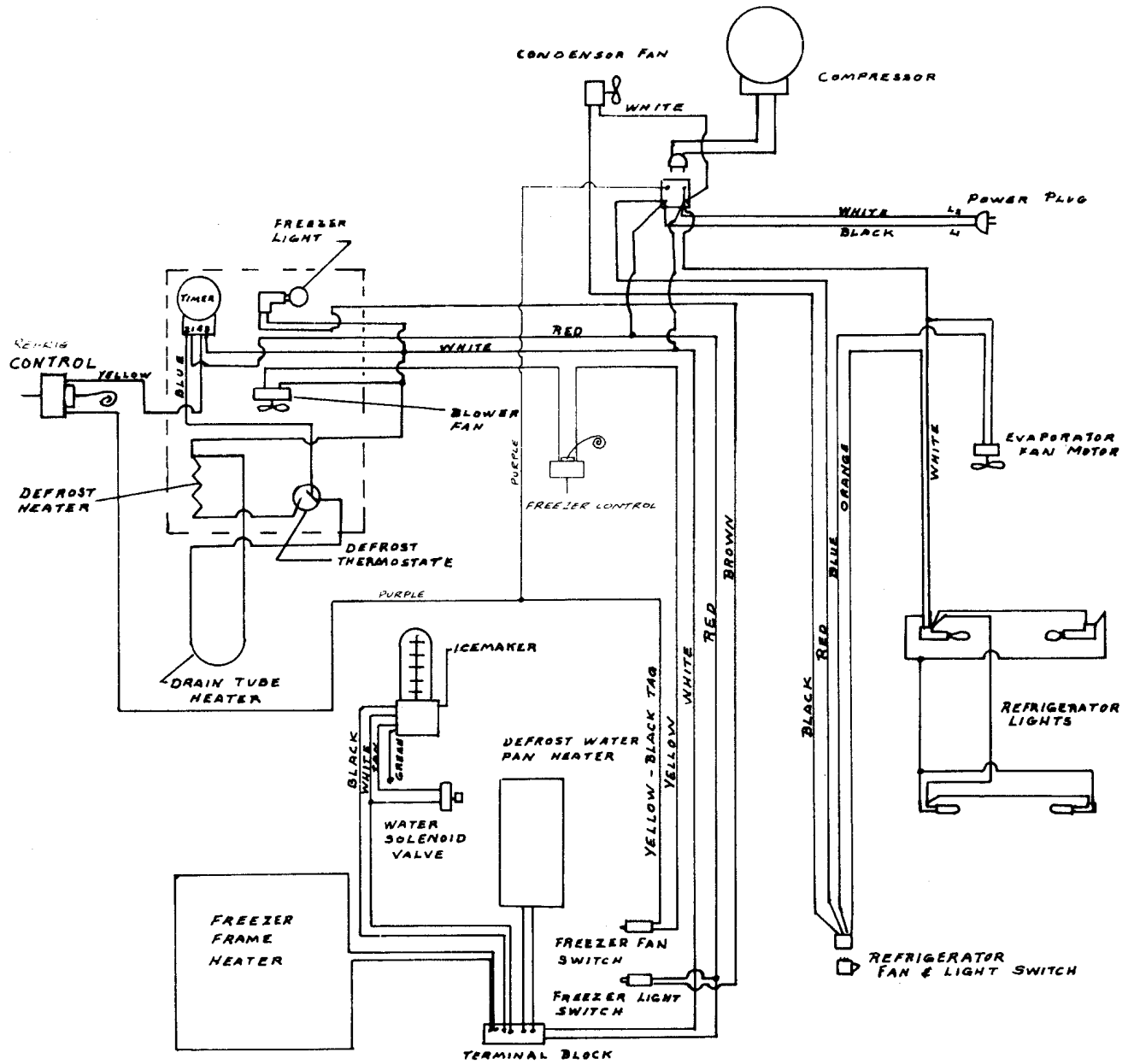

SCHEMATIC

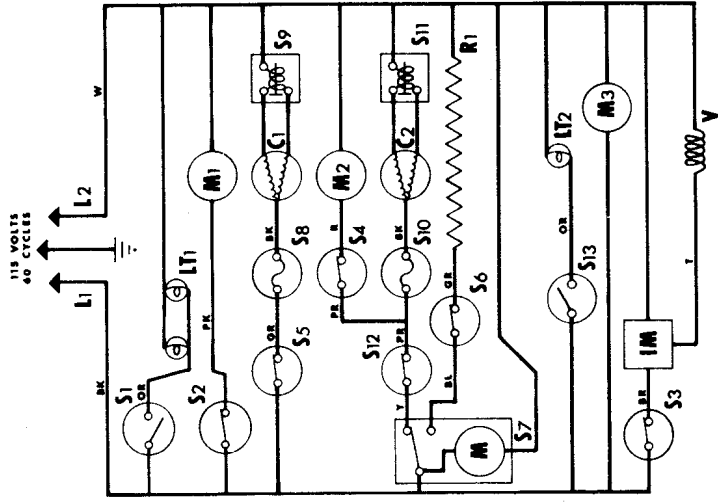

2711 & 2811 WIRING DIAGRAM AFTER SERIAL NO. 455971 TO PRESENT

LEGEND

- Refrigerator Compressor
 - Freezer Compressor
 - Icemaker
 - Line 1
 - Line 2
 - Refrigerator Light
 - Freezer Light
 - Refrigerator Fan Motor
 - Freezer Fan Motor
 - Condenser Fan Motor
 - Defrost Heater
 - Refrigerator Door Switch - Light
 - Refrigerator Door Switch - Fan
 - Freezer Door Switch - Icemaker
 - Freezer Door Switch - Fan
 - Refrigerator Thermostatic Control
 - Defrost Terminator
 - Defrost Timer
 - Refrigerator Overload Protector
 - Refrigerator Compressor Starting Relay
 - Freezer Overload Protector
 - Freezer Compressor Starting Relay
 - Freezer Thermostatic Control
 - Freezer Door Switch
 - Icemaker Water Valve
- BK - Black
 BL - Blue
 BR - Brown
 GR - Gray
 GN - Green
 OR - Orange
 PK - Pink
 PR - Purple
 R - Red
 T - Tan
 W - White
 Y - Yellow
- C1 - Refrigerator Compressor
 C2 - Freezer Compressor
 IM - Icemaker
 L1 - Line 1
 L2 - Line 2
 LT1 - Refrigerator Light
 LT2 - Freezer Light
 M1 - Refrigerator Fan Motor
 M2 - Freezer Fan Motor
 M3 - Condenser Fan Motor
 R1 - Defrost Heater
 S1 - Refrigerator Door Switch - Light
 S2 - Refrigerator Door Switch - Fan
 S3 - Freezer Door Switch - Icemaker
 S4 - Freezer Door Switch - Fan
 S5 - Refrigerator Thermostatic Control
 S6 - Defrost Terminator
 S7 - Defrost Timer
 S8 - Refrigerator Overload Protector
 S9 - Refrigerator Compressor Starting Relay
 S10 - Freezer Overload Protector
 S11 - Freezer Compressor Starting Relay
 S12 - Freezer Thermostatic Control
 S13 - Freezer Door Switch
 V - Icemaker Water Valve
- 2711, 2811 3-79-138-2 Revision C

WIRING DIAGRAM

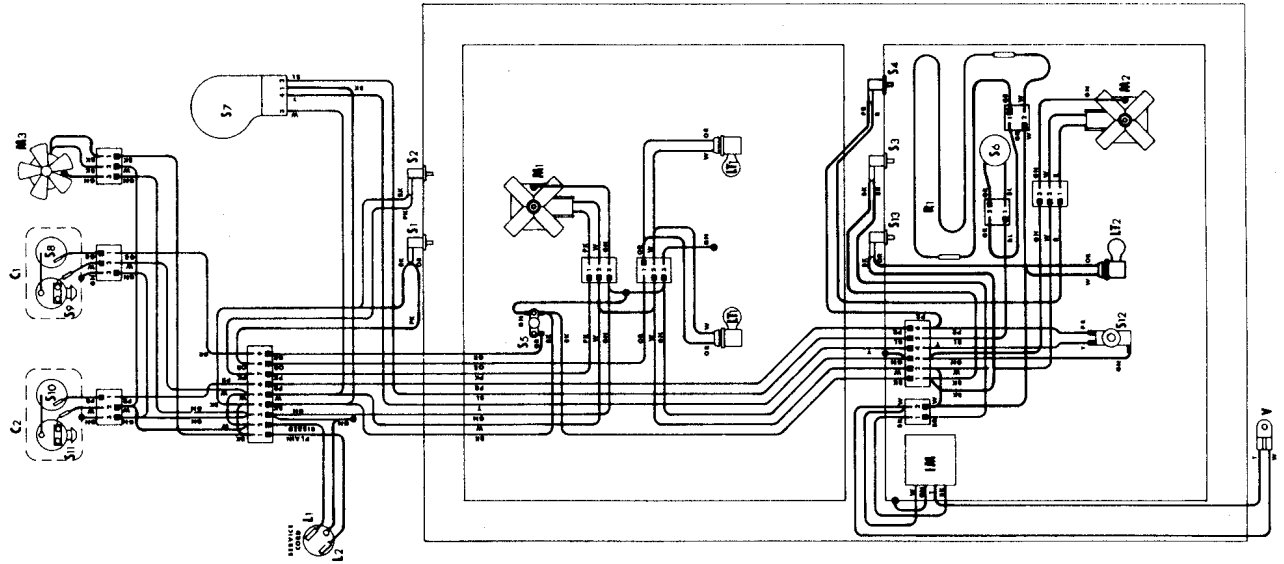

2711
*** WIRING DIAGRAM**
AFTER SERIAL NO. M393733/P397233TO 455970

SCHEMATIC

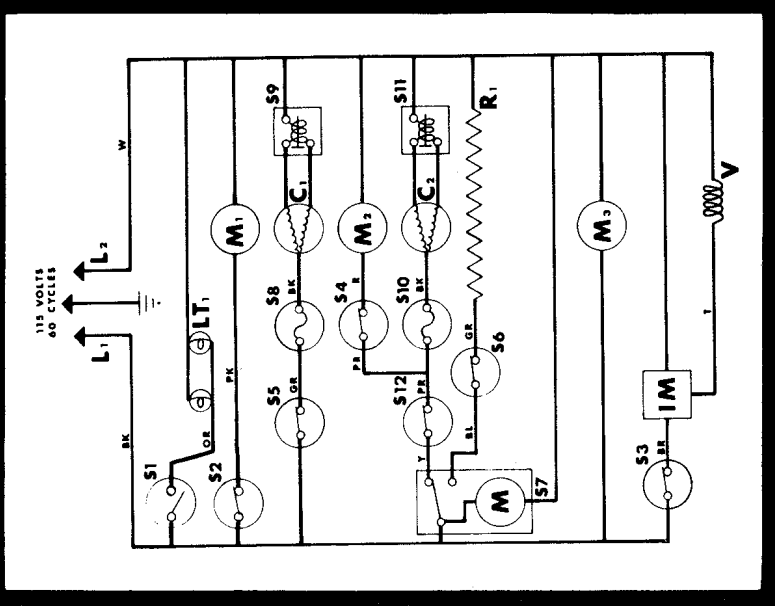

LEGEND

- | | |
|-----|--|
| C1 | - Refrigerator Compressor |
| C2 | - Freezer Compressor |
| IM | - Ice-maker |
| L1 | - Line 1 |
| L2 | - Line 2 |
| LT1 | - Refrigerator Light |
| M1 | - Refrigerator Fan Motor |
| M2 | - Freezer Fan Motor |
| M3 | - Condenser Fan Motor |
| R1 | - Defrost Heater |
| S1 | - Refrigerator Door Switch - Light |
| S2 | - Refrigerator Door Switch - Fan |
| S3 | - Freezer Door Switch - Ice-maker |
| S4 | - Freezer Door Switch - Fan |
| S5 | - Refrigerator Thermostatic Control |
| S6 | - Defrost Terminator |
| S7 | - Defrost Timer |
| S8 | - Refrigerator Overload Protector |
| S9 | - Refrigerator Compressor Starting Relay |
| S10 | - Freezer Overload Protector |
| S11 | - Freezer Compressor Starting Relay |
| S12 | - Freezer Thermostatic Control |
| V | - Ice-maker Water Valve |

2711 3-75-138-1

WIRING DIAGRAM

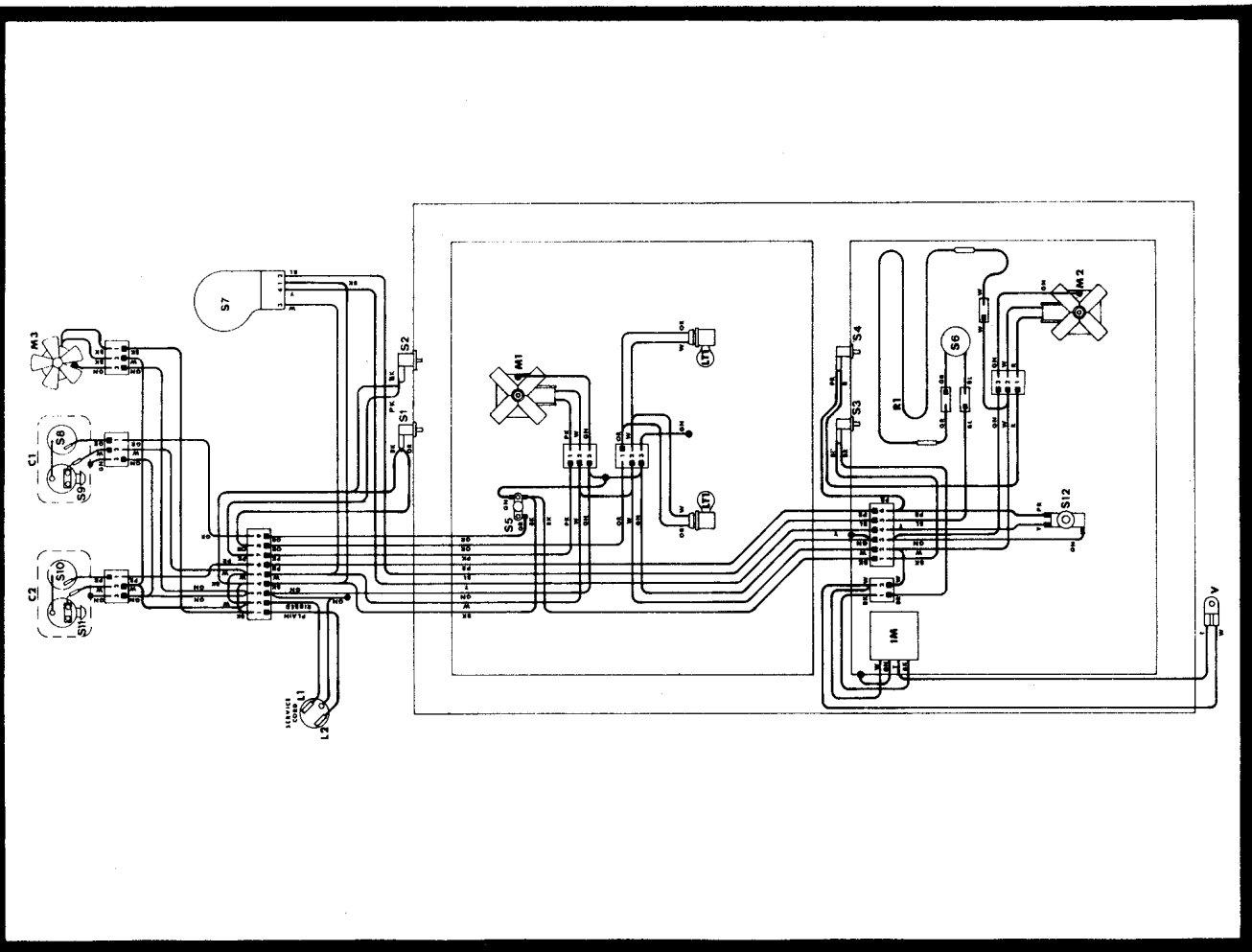

*NOTE: From M393733 to M455970 No Freezer Light

2711
WIRING DIAGRAM
 FROM SERIAL NO. 368247 TO M393733/P397233

SCHEMATIC

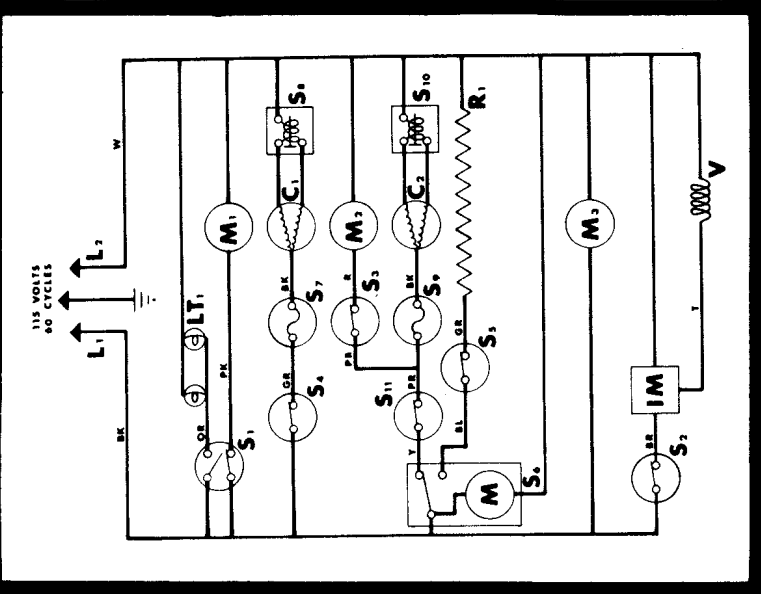

LEGEND

- C1 - Refrigerator Compressor
 - C2 - Freezer Compressor
 - IM - Icemaker
 - L1 - Light 1
 - L2 - Light 2
 - L3 - Light 3
 - L7 - Refrigerator Light
 - M1 - Refrigerator Fan Motor
 - M2 - Freezer Fan Motor
 - M3 - Condenser Fan Motor
 - M - Defrost Heater
 - S1 - Defrost Heater Door Switch
 - S2 - Freezer Door Switch - Icemaker
 - S3 - Freezer Door Switch - Fan
 - S4 - Refrigerator Thermostatic Control
 - S5 - Defrost Terminator
 - S6 - Defrost Timer
 - S7 - Refrigerator Overload Protector
 - S8 - Refrigerator Compressor Starting Relay
 - S9 - Freezer Overload Protector
 - S10 - Freezer Compressor Starting Relay
 - S11 - Freezer Thermostatic Control
 - V - Icemaker Water Valve
- BK - Black
 - BL - Blue
 - BR - Brown
 - CR - Green
 - GN - Gray
 - OR - Orange
 - PX - Pink
 - PR - Purple
 - R - Red
 - WH - White
 - Y - Yellow
- 2711 3-75-138-0

WIRING DIAGRAM

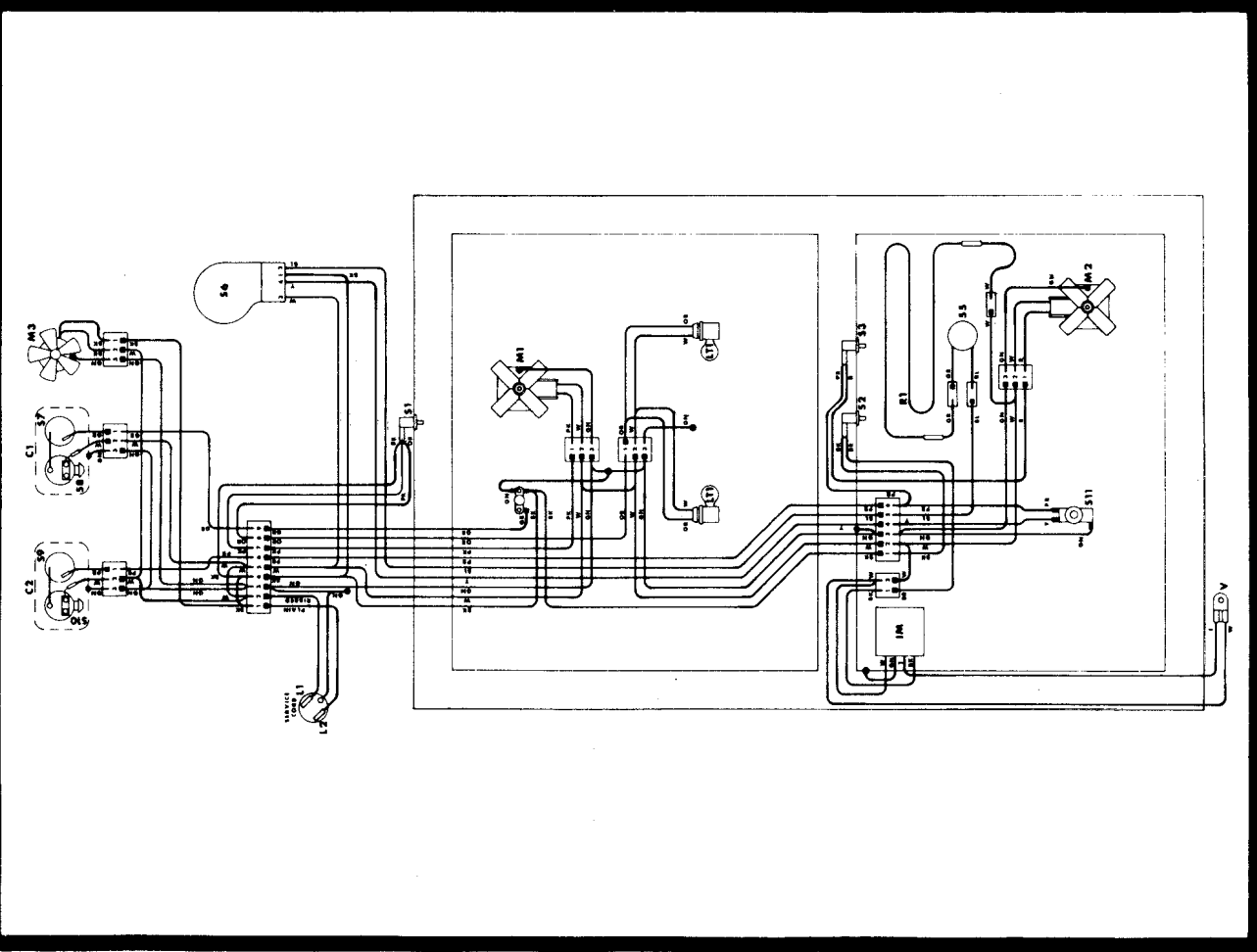

2811
WIRING DIAGRAM
AFTER SERIAL NO. P583741 TO CURRENT PHOENIX PRODUCTION

SCHEMATIC

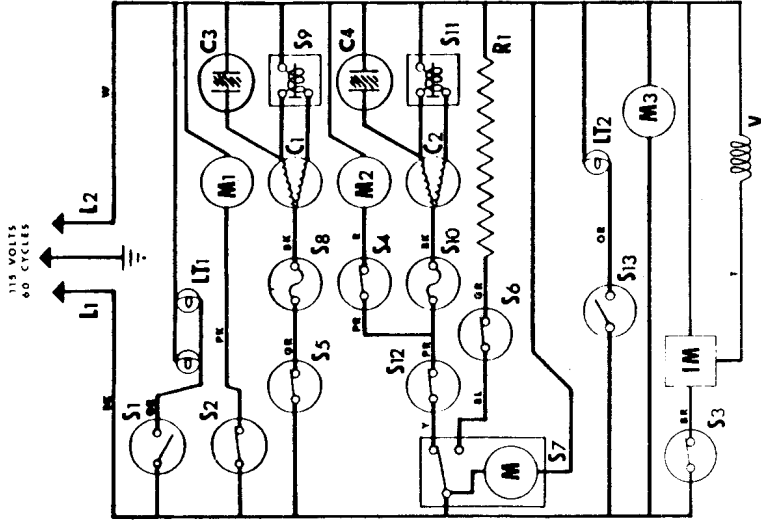

LEGEND

- | | |
|--|-------------|
| — REFRIGERATOR COMPRESSOR | BK — BLACK |
| — FREEZER COMPRESSOR | BL — BLUE |
| — REFRIGERATOR RUNNING CAPACITOR | BR — BROWN |
| — FREEZER RUNNING CAPACITOR | GR — GRAY |
| — ICEMAKER | GN — GREEN |
| — LINE 1 | OR — ORANGE |
| — LINE 2 | PK — PINK |
| — REFRIGERATOR LIGHT | PR — PURPLE |
| — FREEZER LIGHT | R — RED |
| — REFRIGERATOR FAN MOTOR | TR — TAN |
| — FREEZER FAN MOTOR | W — WHITE |
| — CONDENSER FAN MOTOR | Y — YELLOW |
| — DEFROST HEATER | |
| — REFRIGERATOR DOOR SWITCH — LIGHT | |
| — REFRIGERATOR DOOR SWITCH — FAN | |
| — FREEZER DOOR SWITCH — FAN | |
| — FREEZER DOOR SWITCH — ICEMAKER | |
| — REFRIGERATOR THERMOSTATIC CONTROL | |
| — DEFROST TERMINATOR | |
| — DEFROST TIMER | |
| — REFRIGERATOR OVERLOAD PROTECTOR | |
| — REFRIGERATOR COMPRESSOR STARTING RELAY | |
| — FREEZER OVERLOAD PROTECTOR | |
| — FREEZER COMPRESSOR STARTING RELAY | |
| — FREEZER THERMOSTATIC CONTROL | |
| — FREEZER DOOR SWITCH — LIGHT | |
| — ICEMAKER WATER VALVE | |

3-75-138-3

2811

WIRING DIAGRAM

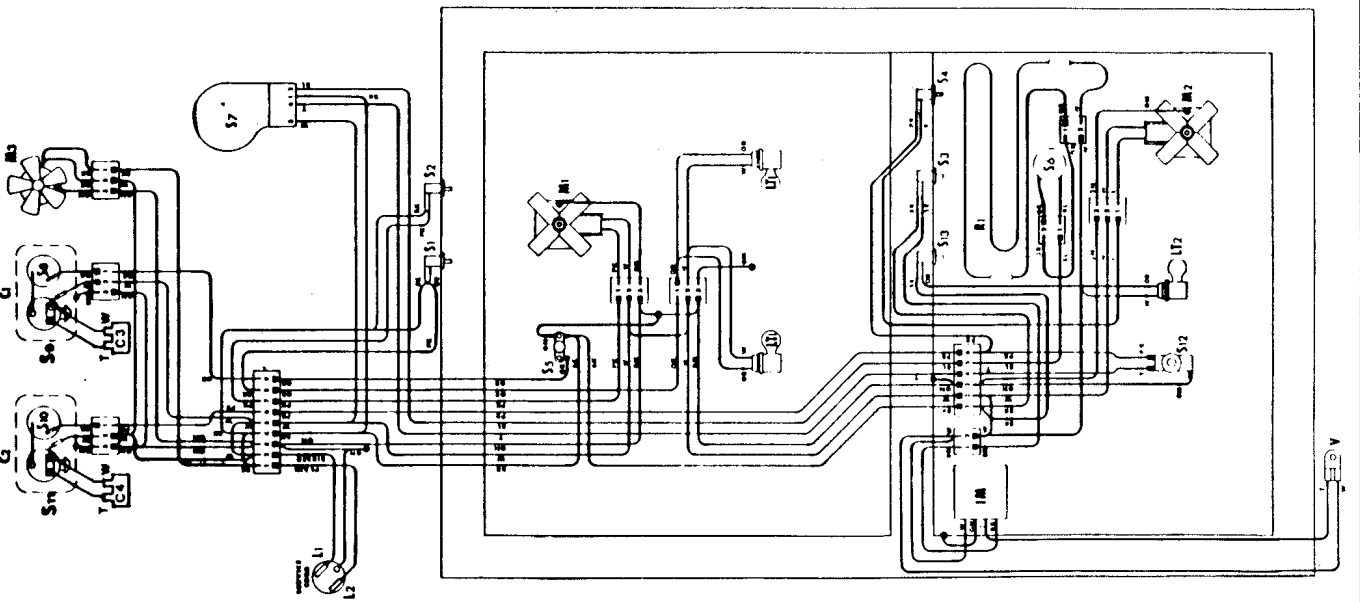

2511RFD WIRING DIAGRAM AFTER SERIAL NO. M393733/P397233 TO M464680

SCHEMATIC

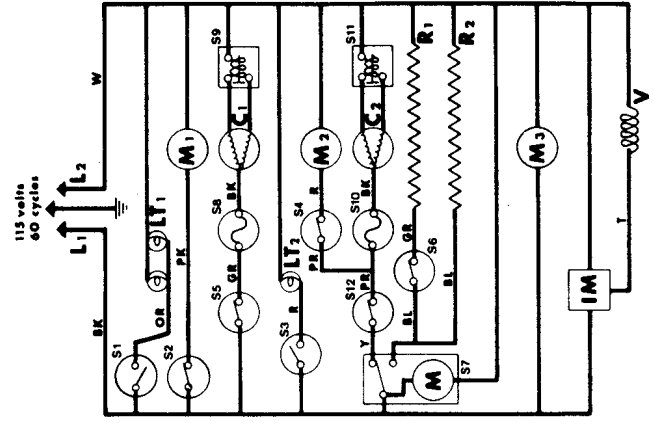

LEGEND

- | | |
|--|---|
| <ul style="list-style-type: none"> C1 - Refrigerator Compressor C2 - Freezer Compressor IM - Icemaker L1 - Line 1 L2 - Line 2 LT1 - Refrigerator Light LT2 - Freezer Light M1 - Refrigerator Fan Motor M2 - Freezer Fan Motor R1 - High Speed Heater R2 - Defrost Heater S1 - Refrigerator Door Switch - Light S2 - Refrigerator Door Switch - Fan S3 - Freezer Door Switch - Light S4 - Freezer Door Switch - Fan S5 - Refrigerator Thermostatic Control S6 - Defrost Timer S7 - Defrost Terminator S8 - Refrigerator Overload Protector S9 - Refrigerator Compressor Starting Relay S10 - Freezer Overload Protector S11 - Freezer Compressor Starting Relay S12 - Freezer Thermostatic Control V - Icemaker Meter Valve | <ul style="list-style-type: none"> BK - Black BL - Blue BR - Brown GR - Gray GN - Green OR - Orange PK - Pink PR - Purple R - Red T - White Y - Yellow |
|--|---|

2511

3-75-067-1

WIRING DIAGRAM

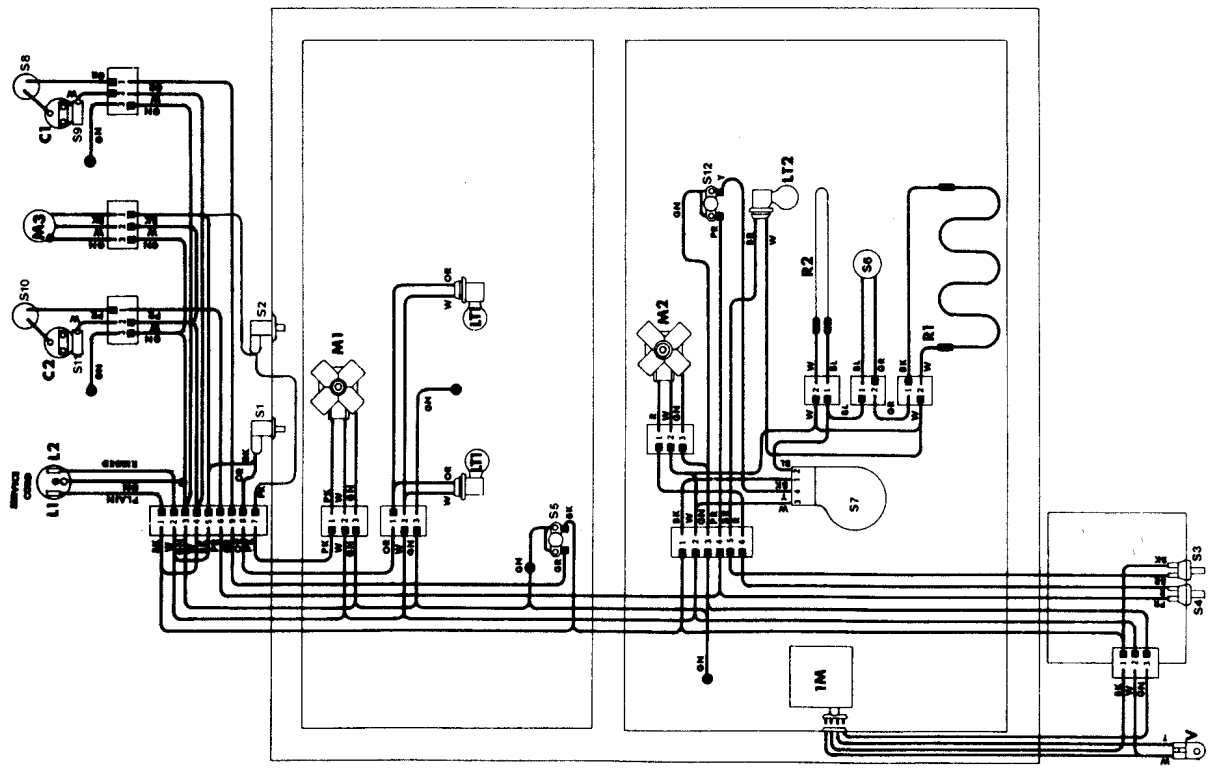

**2411RFD - 2511RFD
WIRING DIAGRAM
AFTER SERIAL NO. 227972 TO M393733/P397233**

SCHEMATIC

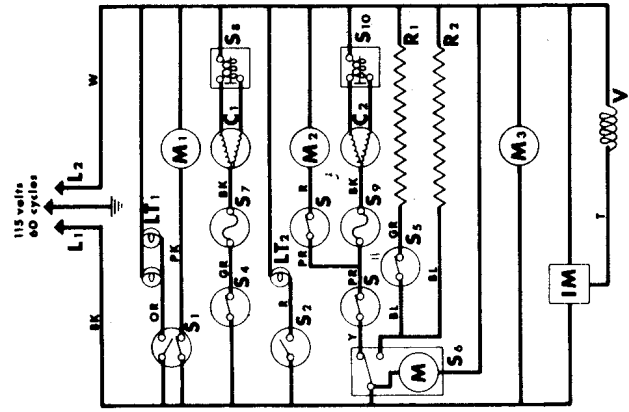

LEGEND

- C1 - Refrigerator Compressor
 - C2 - Freezer Compressor
 - IM - Ice Maker
 - L1 - Line 1
 - L2 - Line 2
 - LT1 - Line Generator Light
 - LT2 - Freezer Light
 - M1 - Refrigerator Fan Motor
 - M2 - Freezer Fan Motor
 - R1 - Defrost Heater
 - R2 - Drain Tube Heater
 - S1 - Refrigerator Door Switch
 - S2 - Freezer Door Switch - Light
 - S3 - Freezer Door Switch - Fan
 - S4 - Refrigerator Thermostatic Control
 - S5 - Defrost Timer
 - S6 - Refrigerator Overload Protector
 - S7 - Refrigerator Compressor Starting Relay
 - S8 - Refrigerator Overload Protector
 - S9 - Freezer Overload Protector
 - S10 - Freezer Compressor Starting Relay
 - S11 - Freezer Thermostatic Control
 - V - Ice Maker Water Valve
- BK - Black
 - BL - Blue
 - BR - Brown
 - GR - Green
 - OR - Orange
 - PK - Pink
 - PR - Purple
 - R - Red
 - T - Tan
 - W - White
 - Y - Yellow

3-75-067-0 R.A

2411RFD, 2511RFD

WIRING DIAGRAM

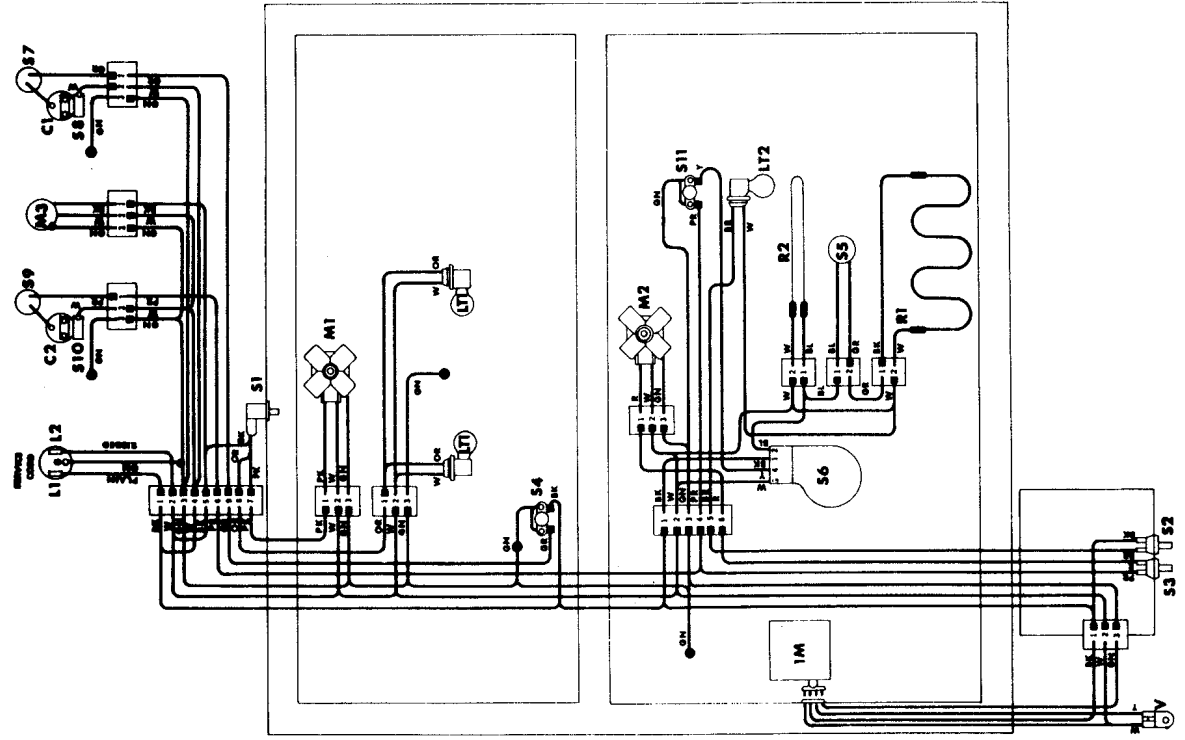

**2411RFD - 2511RFD
WIRING DIAGRAM
PRIOR TO SERIAL NO. 227972**

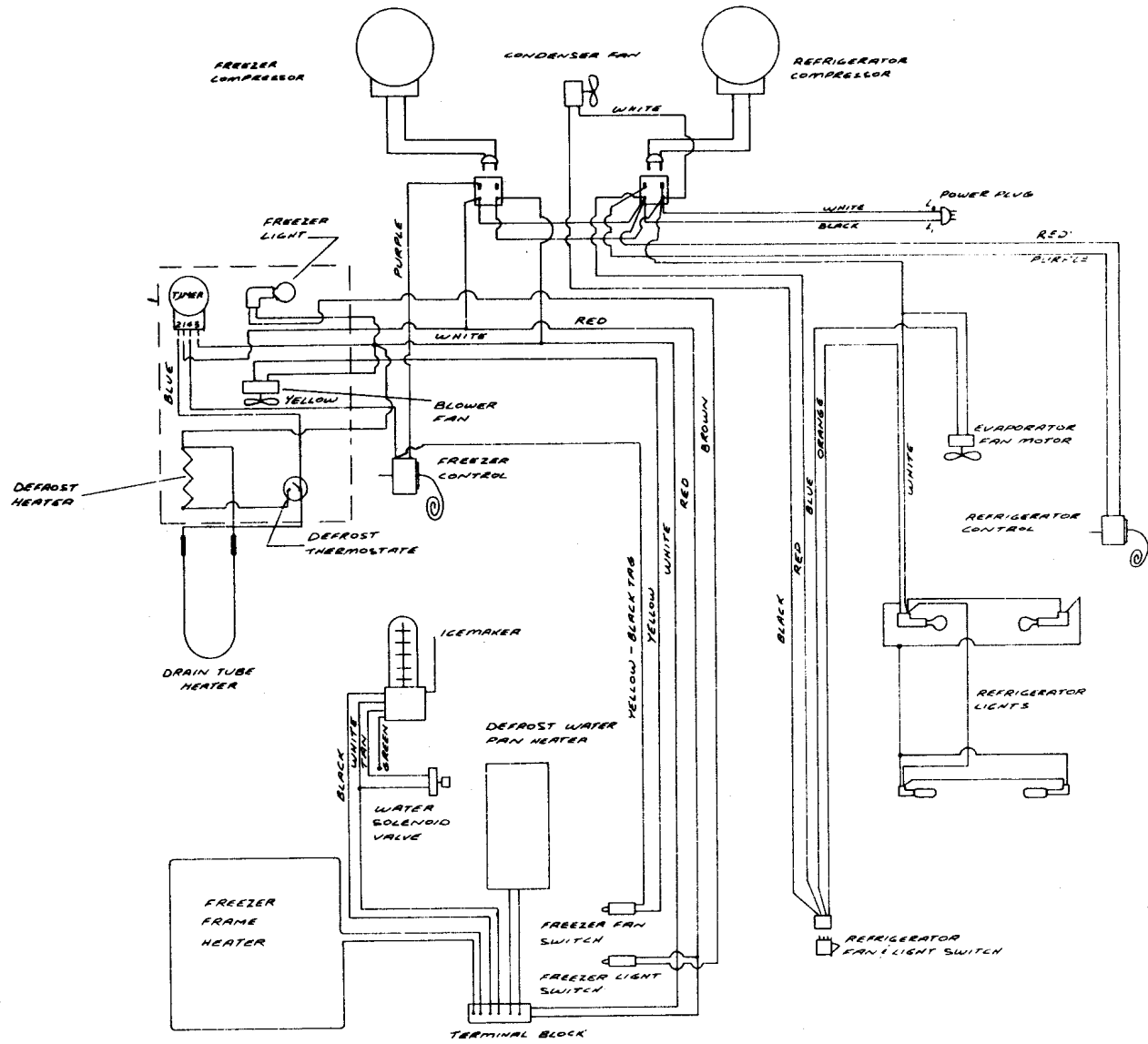

**201R
WIRING DIAGRAM
PRIOR TO SERIAL NO. 227972**

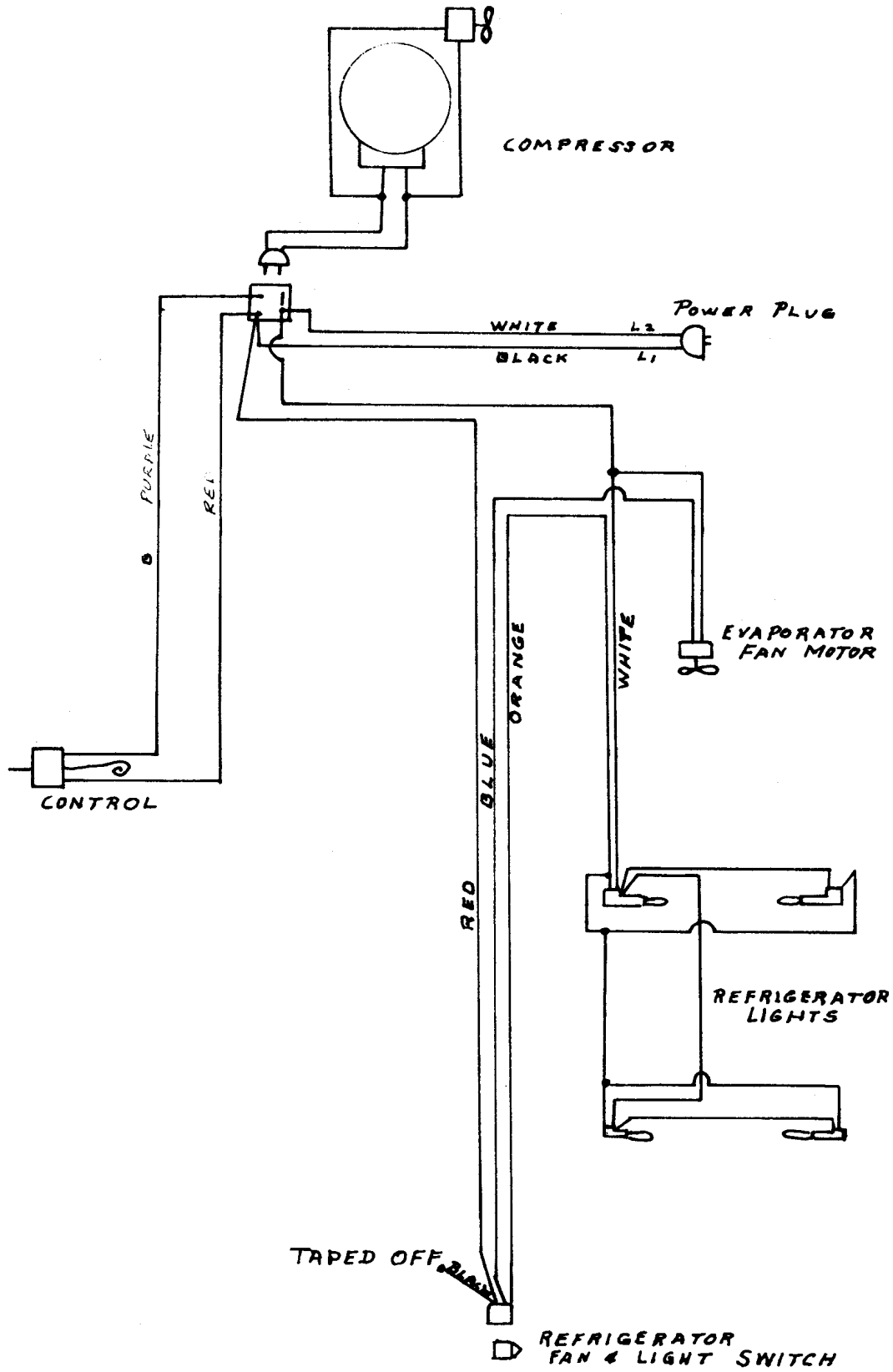

**201FD - 215FD
WIRING DIAGRAM
AFTER SERIAL NO. 227972**

SCHEMATIC

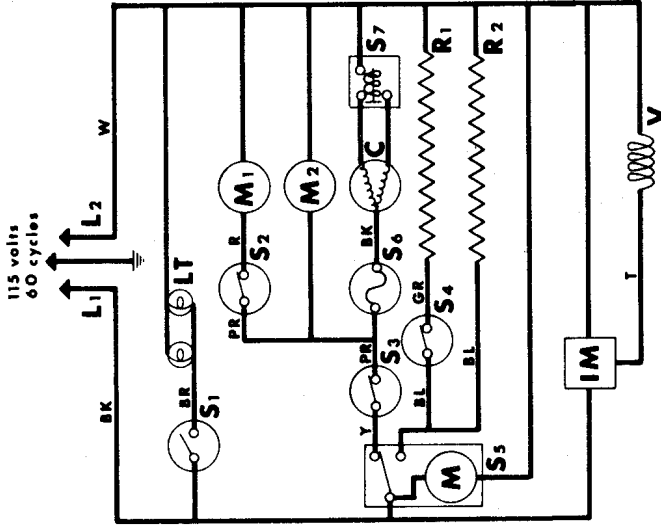

LEGEND

- C - Compressor
 - IM - Icemaker
 - L1 - Line 1
 - L2 - Line 2
 - LT - Light
 - M1 - Evaporator fan motor
 - M2 - Condenser fan motor
 - R1 - Defrost heater
 - R2 - Drain tube heater
 - S1 - Door switch - light
 - S2 - Door switch - fan
 - S3 - Door switch - fan
 - S4 - Thermostatic control
 - S5 - Defrost timer
 - S6 - Defrost terminator
 - S7 - Compressor overload protector
 - V - Valve
- 201 FD, 215 FD 3-75-063-0**

WIRING DIAGRAM

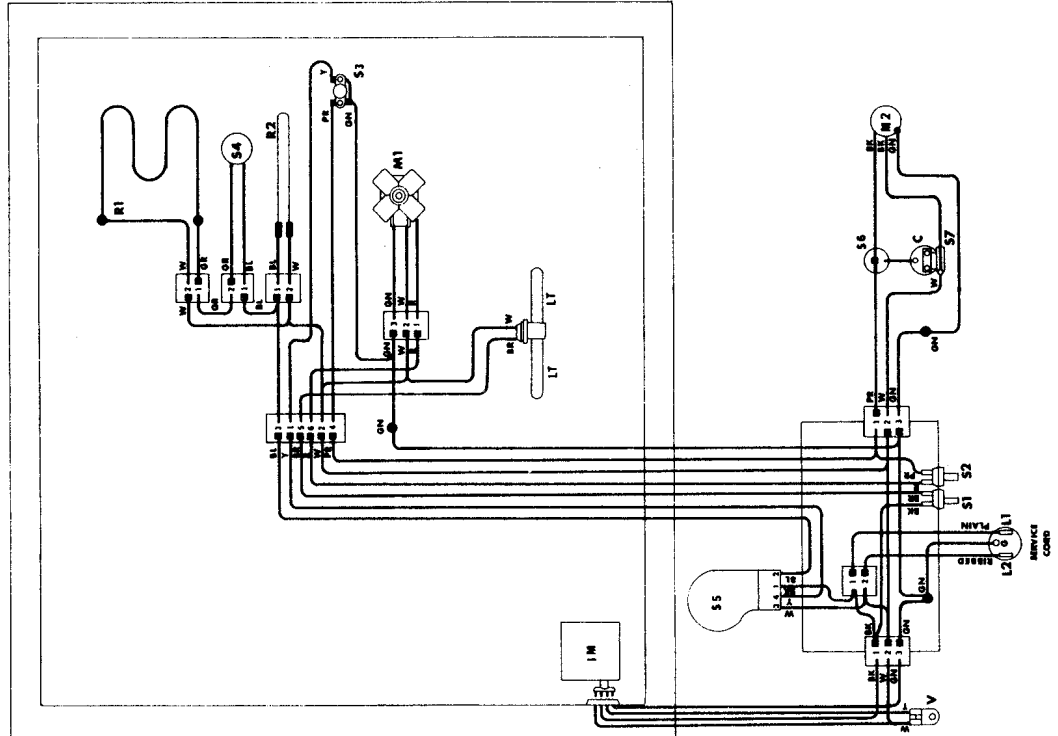

**201FD
WIRING DIAGRAM
PRIOR TO SERIAL NO. 227972**

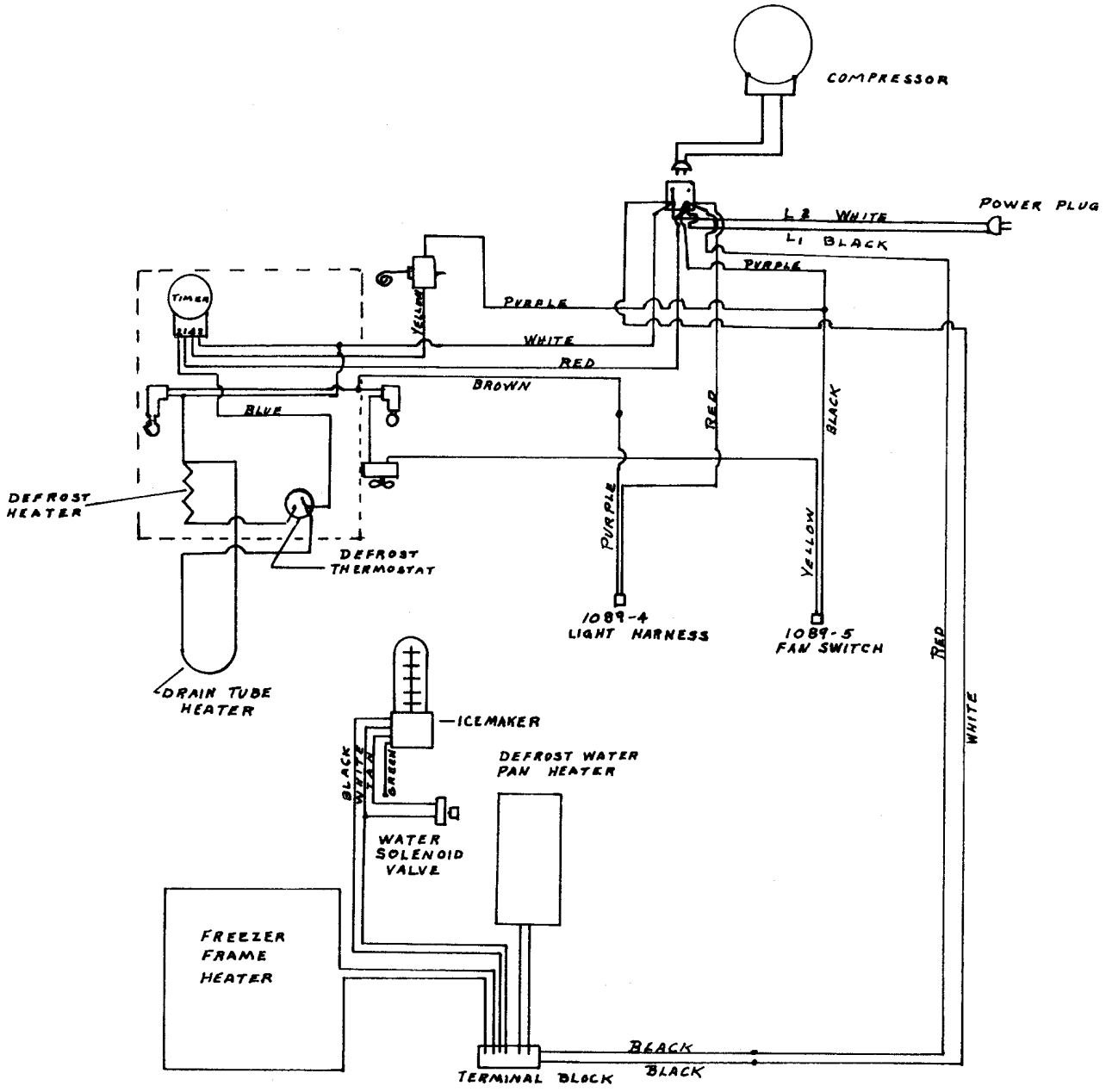

**2011 ICE
WIRING DIAGRAM
AFTER SERIAL NO. 393403**

SCHEMATIC

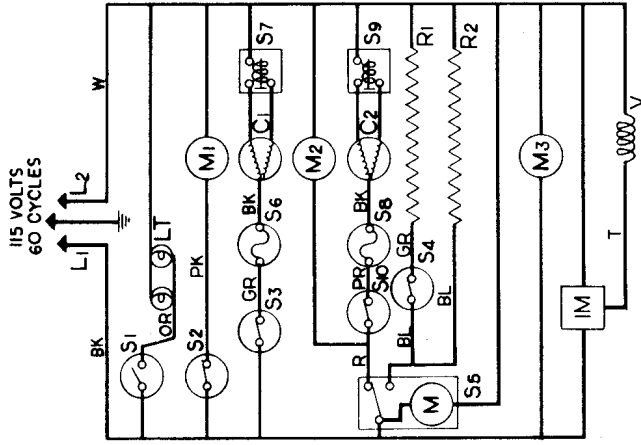

LEGEND

- Refrigerator Compressor
 - Freezer Compressor
 - Icemaker
 - Line 1
 - Line 2
 - Refrigerator Light
 - Refrigerator Fan Motor
 - Freezer Fan Motor
 - Condenser Fan Motor
 - Defrost Heater
 - Drain Tube Heater
 - Refrigerator Door Switch - Light
 - Refrigerator Door Switch - Fan
 - Refrigerator Thermostatic Control
 - Defrost Terminator
 - Defrost Timer
 - Refrigerator Overload Protector
 - Refrigerator Compressor Starting Relay
 - Freezer Overload Protector
 - Freezer Compressor Starting Relay
 - Freezer Thermostatic Control
 - Icemaker Water Valve
- BK - Black
 - BL - Blue
 - GR - Gray
 - GN - Green
 - OR - Orange
 - PK - Pink
 - PR - Purple
 - R - Red
 - T - Tan
 - W - White

2011 ICE 375-1510

WIRING DIAGRAM

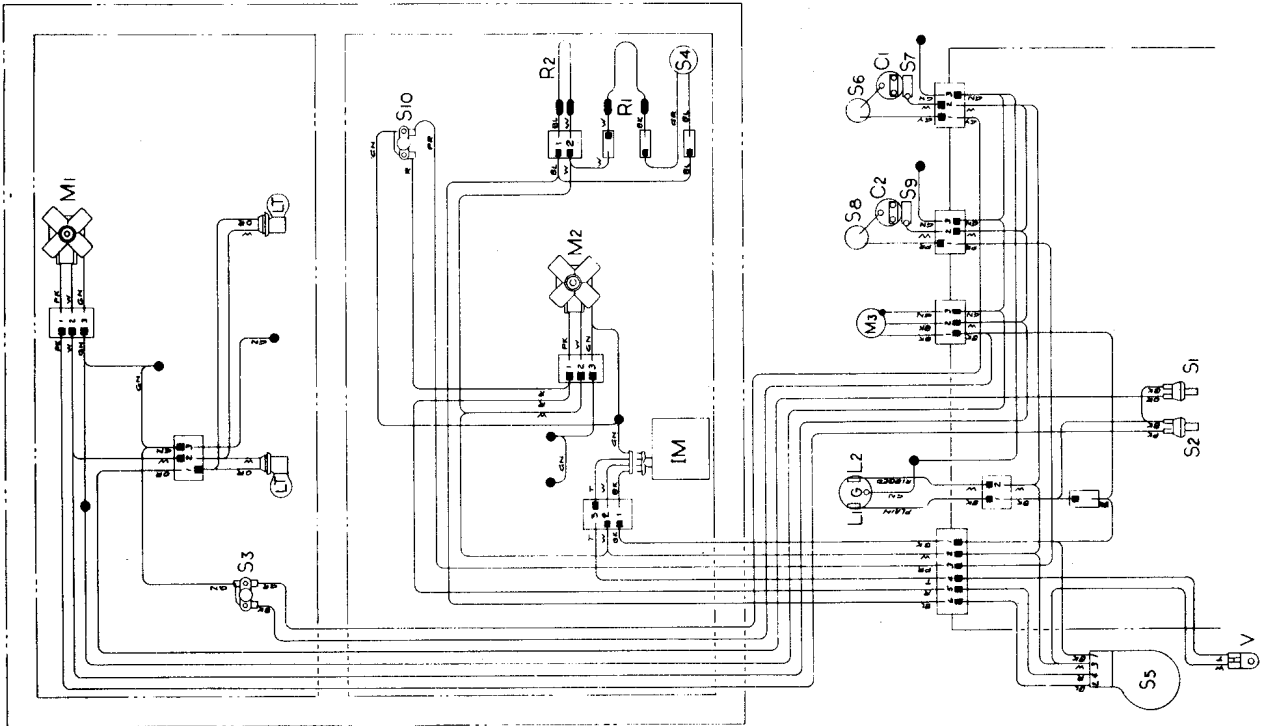

249R - 249RP
WIRING DIAGRAM
 AFTER SERIAL NO. 227972

WIRING DIAGRAM

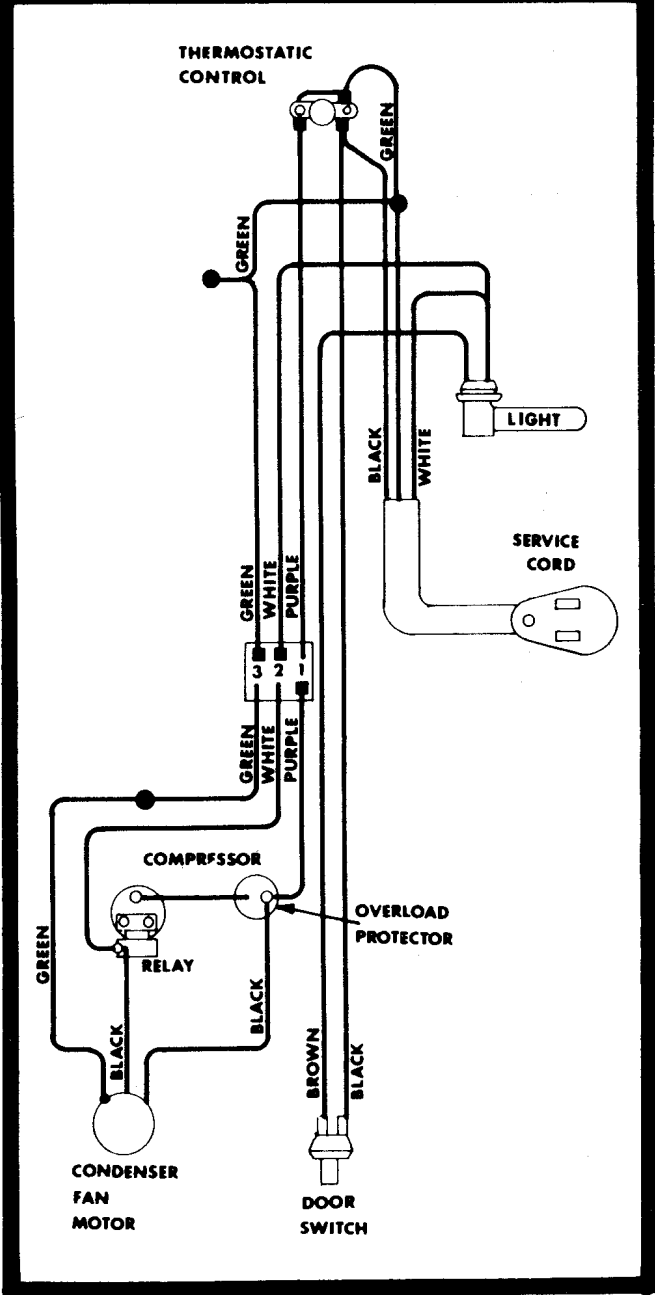

SCHEMATIC

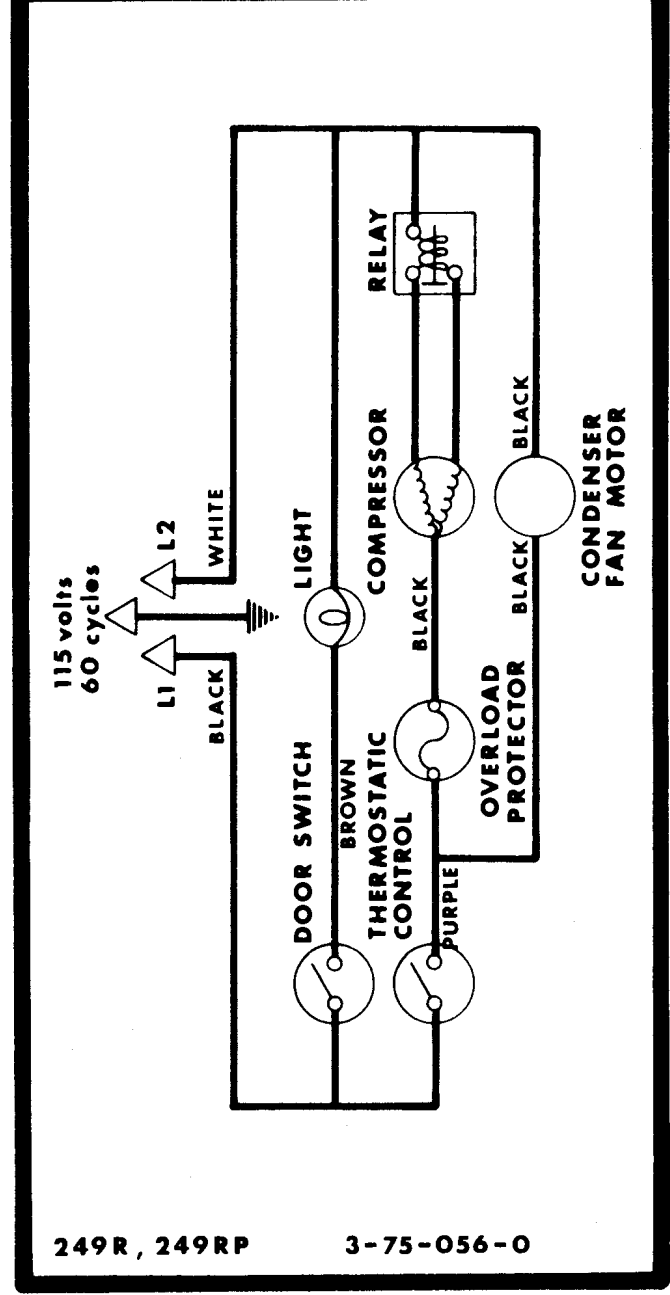

249R, 249RP 3-75-056-0

BEGINNING WITH SERIAL NUMBER 662466

**WIRING DIAGRAM
MODEL 249FF**

WARNING

This wiring information is provided for use by qualified service personnel only. Disconnect appliance from electrical supply before beginning service. Be sure all grounding devices are connected when service is completed. Failure to observe the above warnings may result in severe electrical shock.

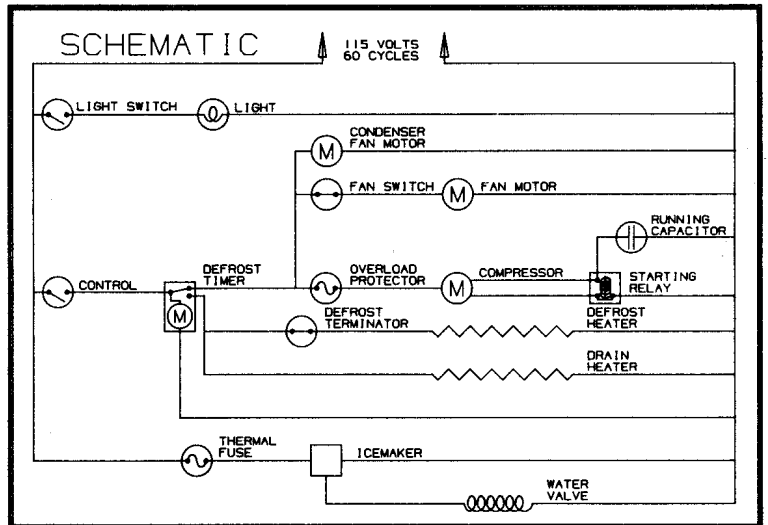
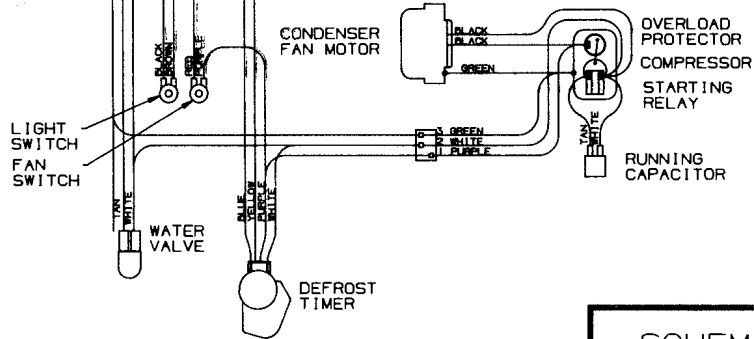
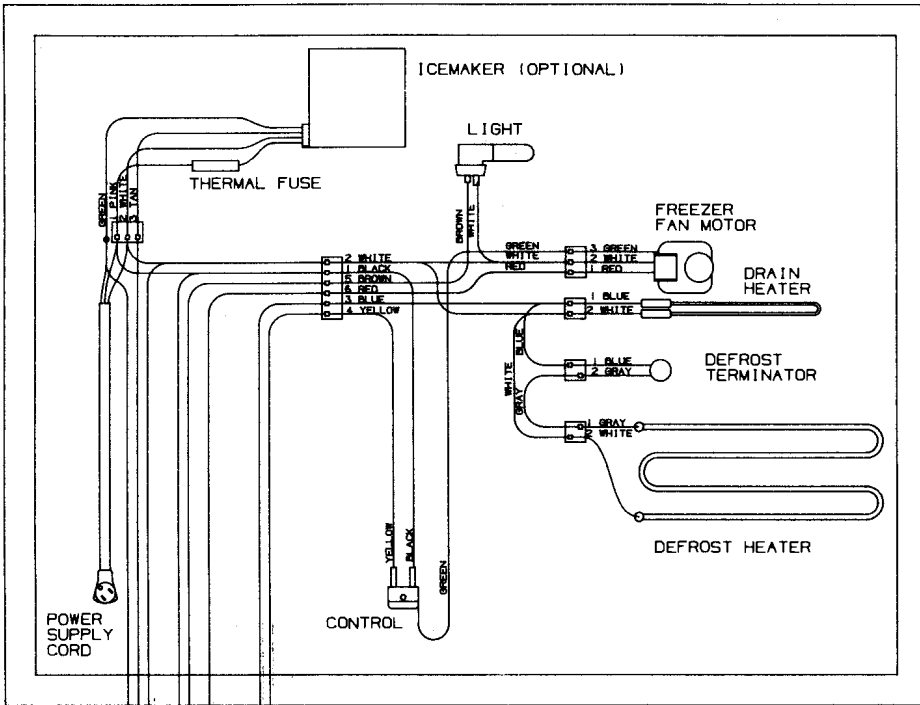

**244RFD - 249FF
WIRING DIAGRAM
AFTER SERIAL NO. 227972
UP TO 662466**

SCHEMATIC

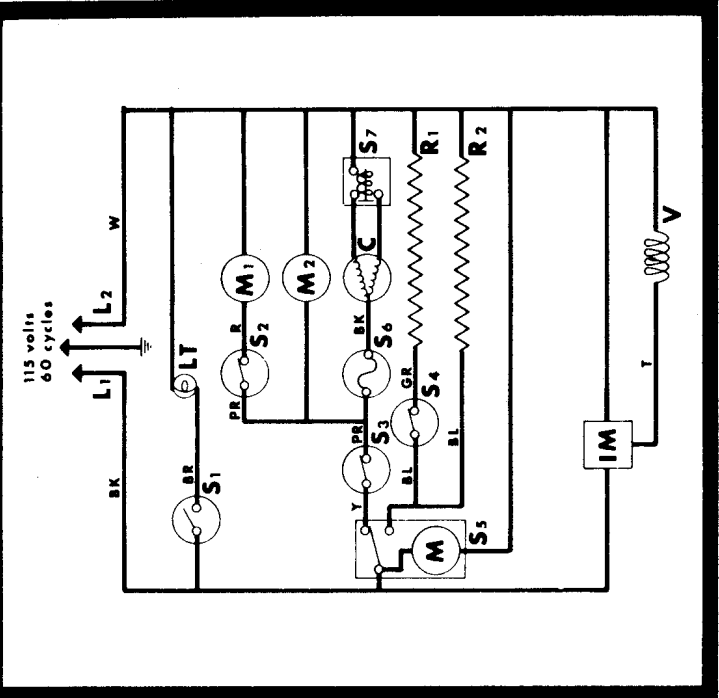

LEGEND

- C - Compressor
 - IM - Icemaker
 - L1 - Line I
 - L2 - Line II
 - LT - Light
 - M1 - Evaporator Fan Motor
 - M2 - Condenser Fan Motor
 - R1 - Defrost Heater
 - R2 - Drain Tube Heater
 - S1 - Door Switch -Light
 - S2 - Door Switch -Fan
 - S3 - Thermostatic Control
 - S4 - Defrost Terminator
 - S5 - Defrost Timer
 - S6 - Compressor Overload Protector
 - S7 - Compressor Starting Relay
 - V - Valve
- BK - Black
 - BL - Blue
 - BR - Brown
 - GR - Gray
 - GN - Green
 - PR - Purple
 - R - Red
 - T - Tan
 - W - White
 - Y - Yellow

244RFD, 249FF 3-75-057-0

WIRING DIAGRAM

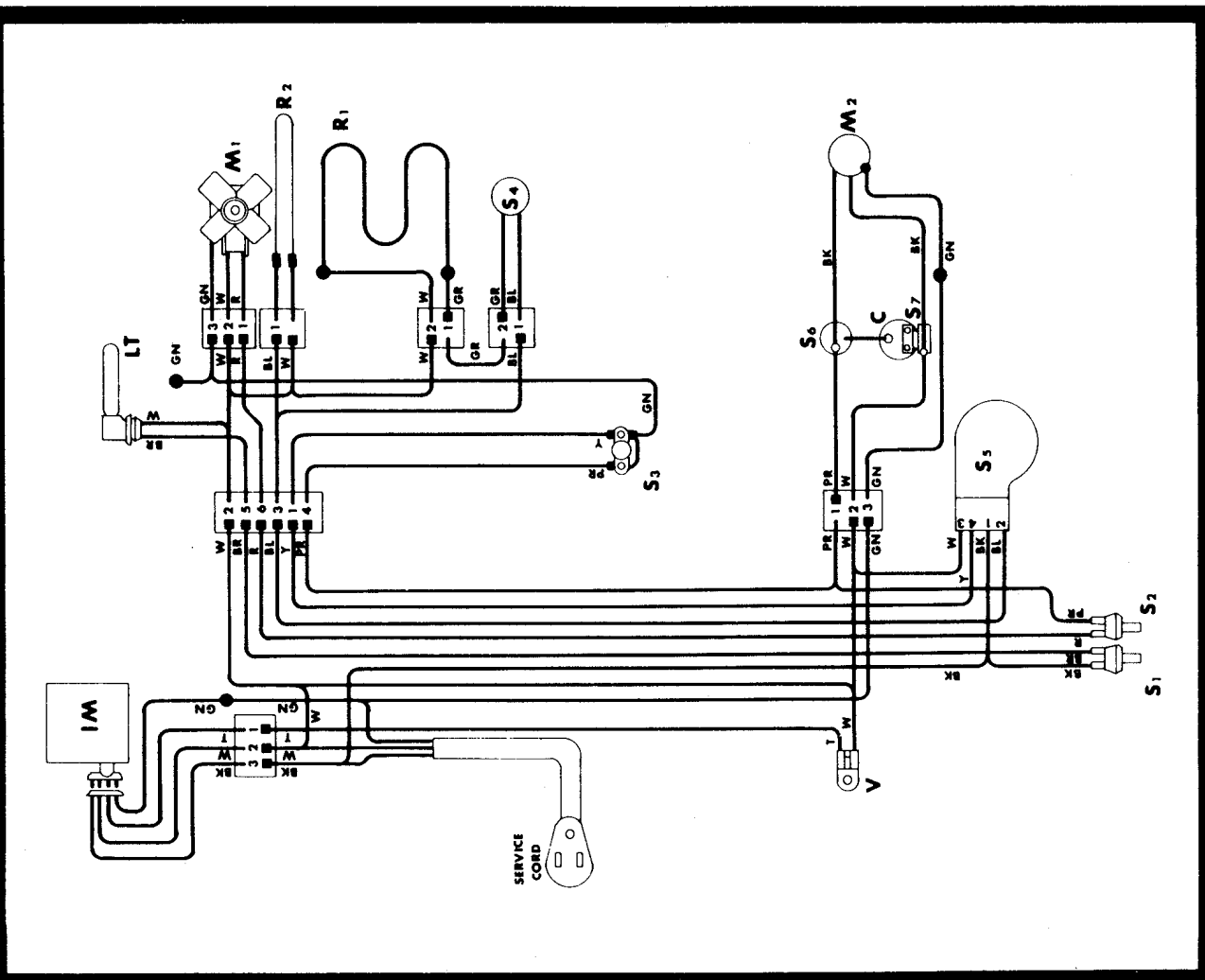

BEGINNING WITH SERIAL NUMBER 662066

**WIRING DIAGRAM
MODEL 245 RFD**

⚠ WARNING

This wiring information is provided for use by qualified service personnel only. Disconnect appliance from electrical supply before beginning service. Be sure all grounding devices are connected when service is completed. Failure to observe the above warnings may result in severe electrical shock.

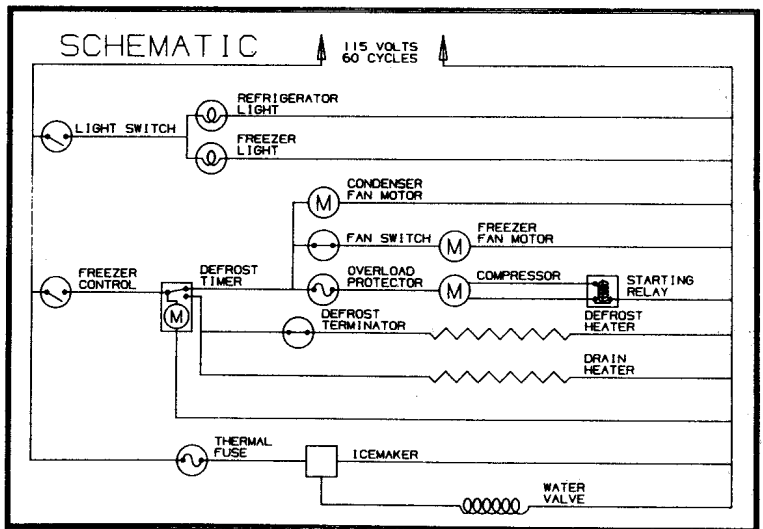
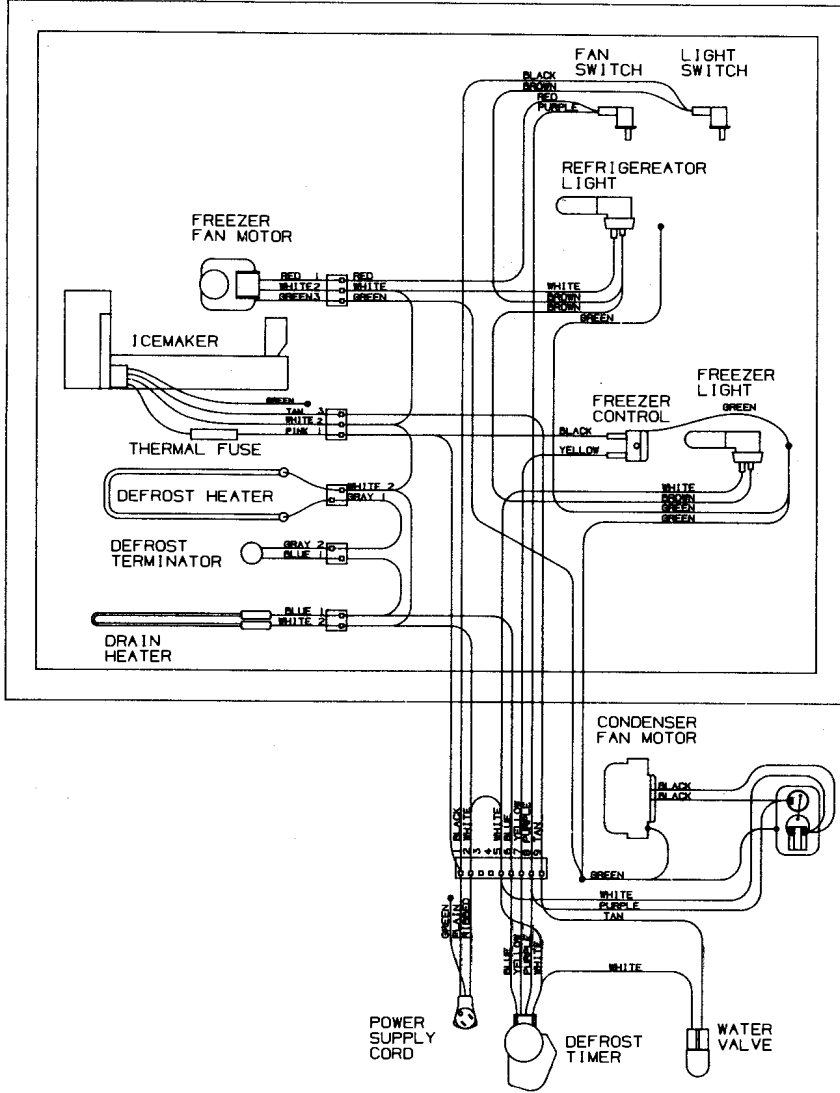

PART NUMBER 3752260 REV B

245
WIRING DIAGRAM
 AFTER SERIAL NO. 464681
 UP TO 662066

SCHEMATIC

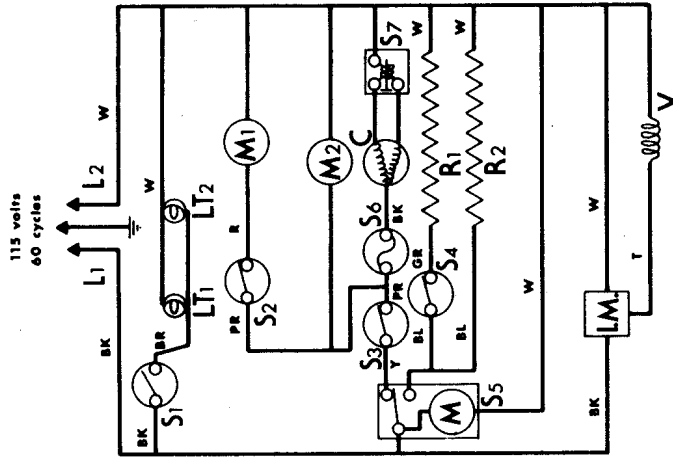

LEGEND

- | | |
|-----|-----------------------------|
| C | - Compressor |
| IM | - Ice Maker |
| L1 | - Line 1 |
| L2 | - Line 2 |
| LT1 | - Refrigerator Light |
| LT2 | - Freezer Light |
| M1 | - Freezer Fan Motor |
| M2 | - Condenser Fan Motor |
| R1 | - Defrost Heater |
| R2 | - Drain Tube Heater |
| S1 | - Door Switch - Light |
| S2 | - Door Switch - Fan |
| S3 | - Thermostat |
| S4 | - Defrost Terminator |
| S5 | - Defrost Timer |
| S6 | - Compressor Overload |
| S7 | - Compressor Starting Relay |
| S8 | - Valve |

245 RFD 3-75-160-0

WIRING DIAGRAM

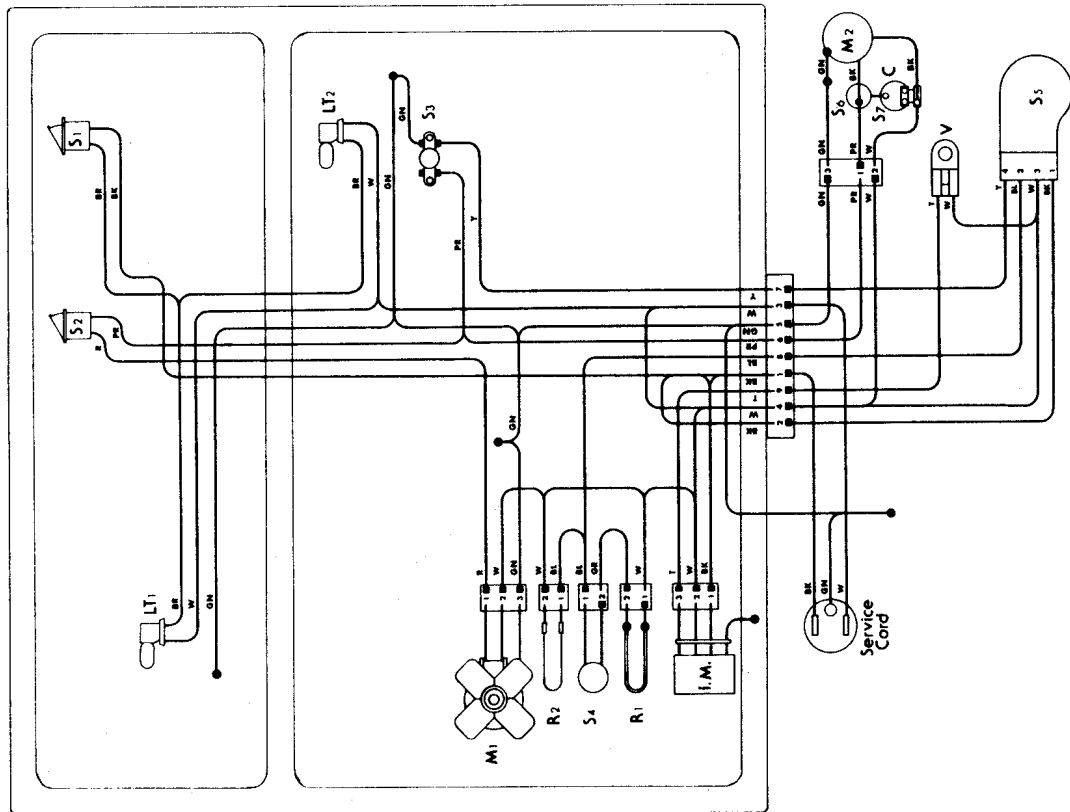

BEGINNING WITH SERIAL NUMBER 659116

**WIRING DIAGRAM
MODEL 801**

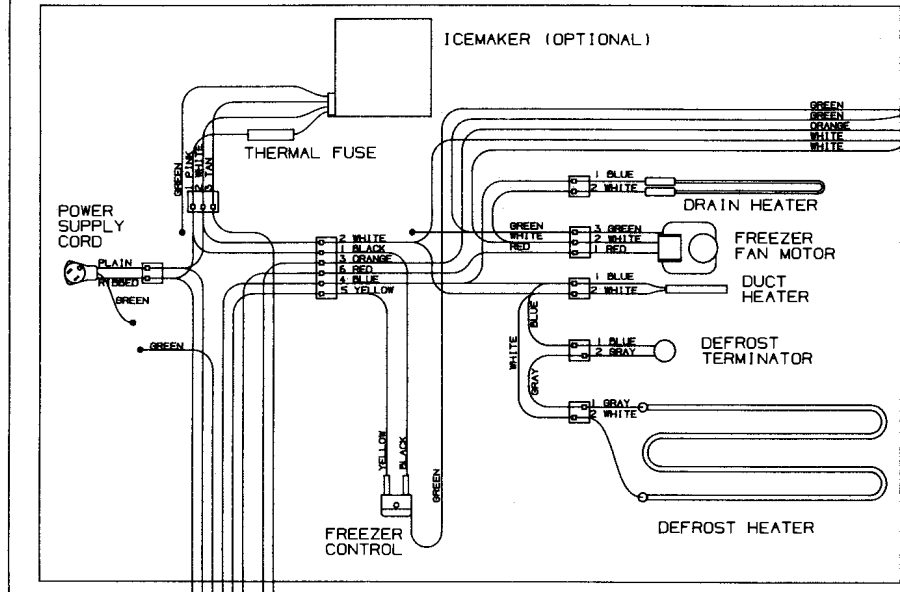

⚠ WARNING

This wiring information is provided for use by qualified service personnel only. Disconnect appliance from electrical supply before beginning service. Be sure all grounding devices are connected when service is completed. Failure to observe the above warnings may result in severe electrical shock.

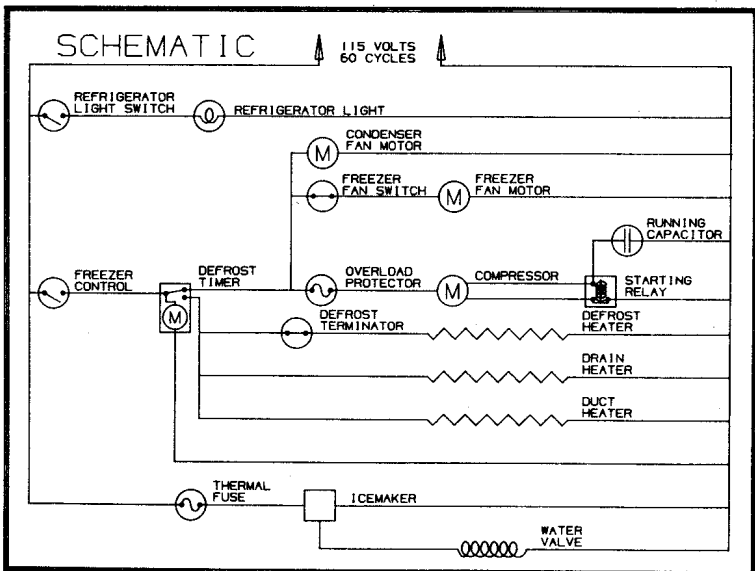
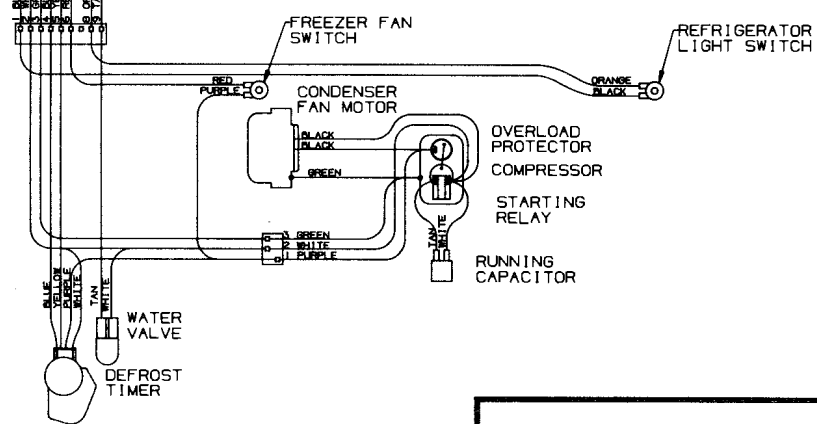

PART NUMBER 3752280 REV B

**22IM
WIRING DIAGRAM
AFTER SERIAL NO. 509241**

SCHEMATIC

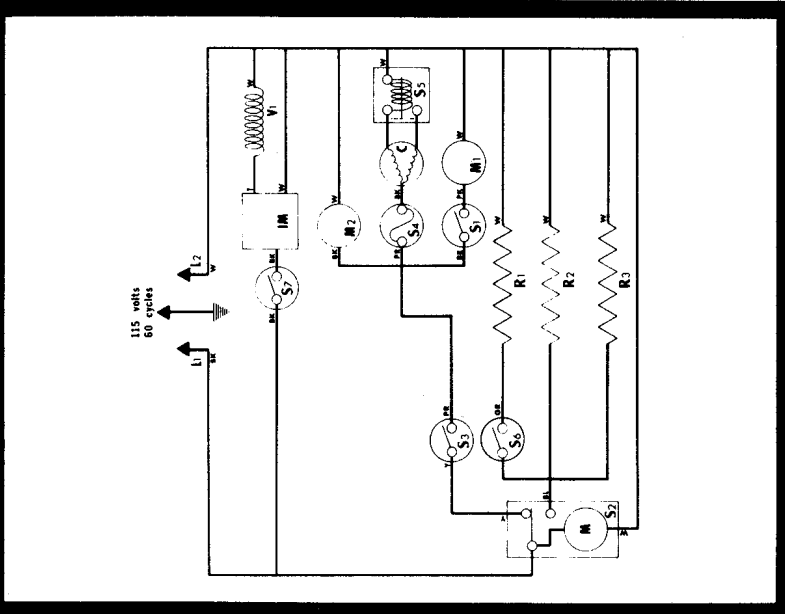

LEGEND

- C - Compressor
 - IM - Icemaker
 - L1 - Line 1
 - L2 - Line 2
 - M1 - Evaporator Fan Motor
 - M2 - Condenser Fan Motor
 - R1 - Defrost Heater
 - R2 - Drain Tube Heater
 - R3 - Fan Through Heater
 - S1 - Fan Door Switch
 - S2 - Defrost Timer
 - S3 - Thermostatic Control
 - S4 - Compressor Overload Protector
 - S5 - Compressor Starting Relay
 - S6 - Defrost Terminator
 - S7 - Icemaker Door Switch
 - V1 - Icemaker Water Valve
- 22 I.M. 3-75-084-1**

WIRING DIAGRAM

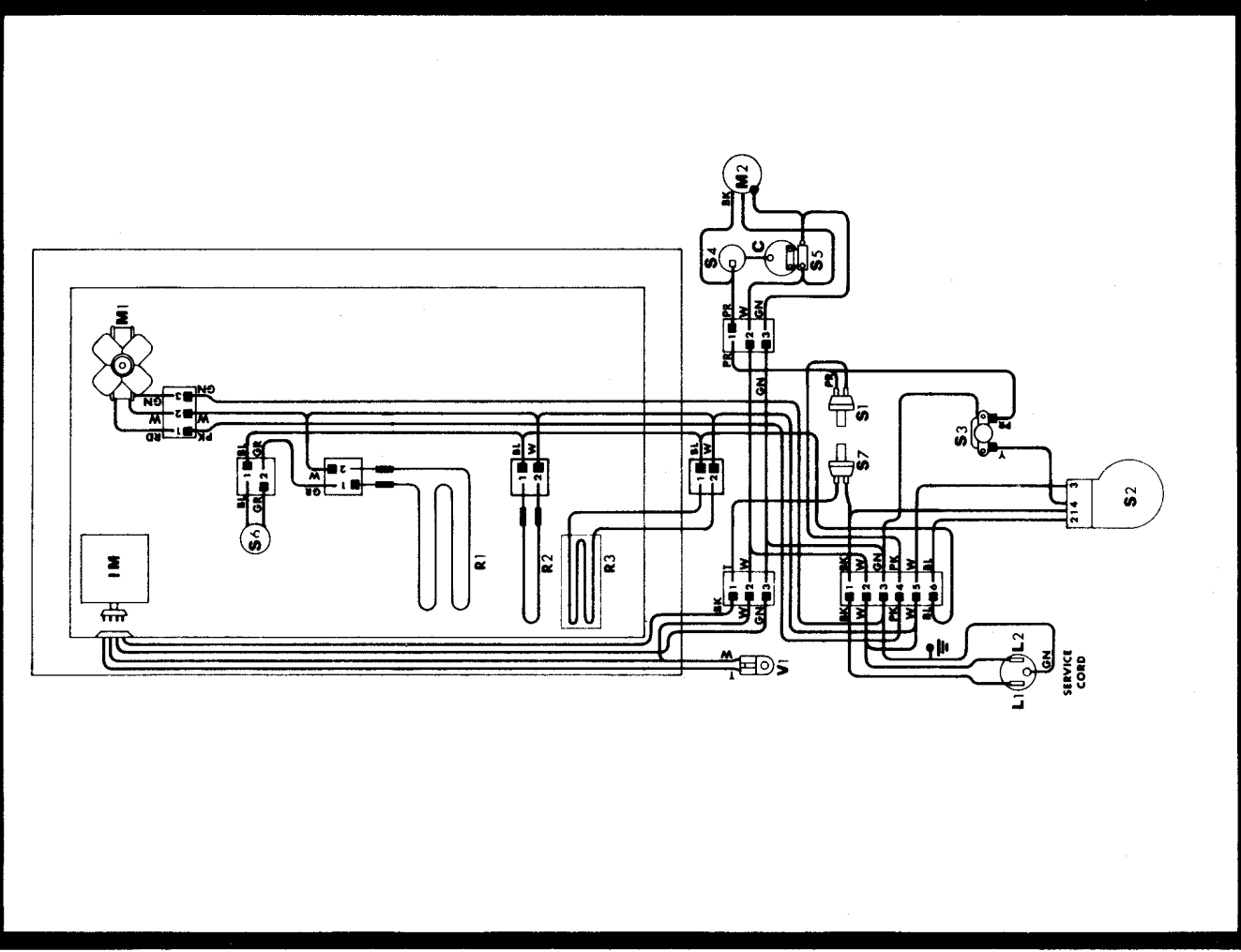

22 IM WIRING DIAGRAM AFTER SERIAL NO. 271942 TO 509240

SCHEMATIC

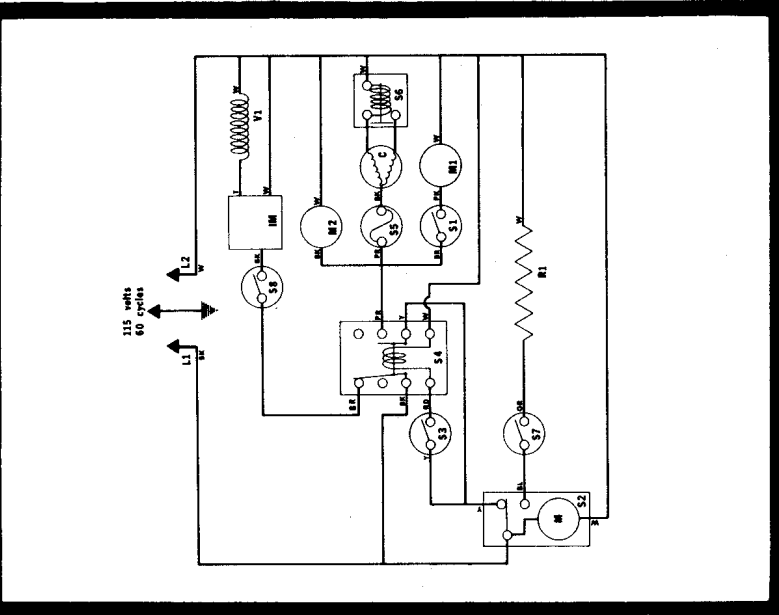

LEGEND

- | | |
|------------------------------------|-------------|
| C - Compressor | BK - Black |
| IM - Icemaker | BL - Blue |
| L1 - Line 1 | BR - Brown |
| L2 - Line 2 | GR - Gray |
| M1 - Evaporator Fan Motor | GN - Green |
| M2 - Condenser Fan Motor | OR - Orange |
| R1 - Defrost Heater | PK - Pink |
| S1 - Fan Door Switch | PR - Purple |
| S2 - Defrost Timer | R - Red |
| S3 - Thermostat Control | T - Tan |
| S4 - IM - Compressor Relay | W - White |
| S5 - Compressor Overload Protector | Y - Yellow |
| S6 - Compressor Starting Relay | |
| S7 - Defrost Terminator | |
| S8 - Icemaker Door Switch | |
| V1 - Icemaker Water Valve | |
- 22 IM**
3-75-084-O

WIRING DIAGRAM

