

# **KitchenAid**

TECHNICAL EDUCATION

## **Over-The-Range Microwave Oven**



Model: KHMS175M

## **FORWARD**

This KitchenAid Job Aid, "Over-The-Range Microwave Oven," (Part No. 4317357), provides the technician with information on the installation, operation, and service of the Over-The-Range Microwave Oven. It is to be used as a training Job Aid and Service Manual.

The Wiring Diagrams and Strip Circuits used in this Job Aid are typical and should be used for training purposes only. Always use the Wiring Diagram supplied with the product when servicing the unit.

## **GOALS AND OBJECTIVES**

The goal of this Job Aid is to provide detailed information that will enable the service technician to properly diagnose malfunctions and repair the Over-The-Range Microwave Oven.

The objectives of this Job Aid are to:

- Understand and follow proper safety precautions.
- Successfully troubleshoot and diagnose malfunctions.
- Successfully perform necessary repairs.
- Successfully return the Microwave Oven to its proper operational status.

WHIRLPOOL CORPORATION assumes no responsibility for any repairs made on our products by anyone other than Authorized Service Technicians.

# TABLE OF CONTENTS

	Page
<b>GENERAL</b> .....	1-1
Warning To Service Technicians .....	1-1
Precautions To Be Observed Before And During Servicing To Avoid Possible Exposure To Excessive Microwave Energy .....	1-2
R.F. Leakage Test .....	1-3
Precautions To Be Observed When Troubleshooting .....	1-4
Model & Serial Number Designations .....	1-5
Model & Serial Number Label And Tech Sheet Locations .....	1-6
Specifications .....	1-7
KitchenAid Microwave Oven Warranty .....	1-9
<b>INSTALLATION INFORMATION</b> .....	2-1
Adjusting The Exhaust Airflow .....	2-1
Removing & Reinstalling The Microwave Oven .....	2-2
<b>THEORY OF OPERATION</b> .....	3-1
Microwave Operation .....	3-1
<b>COMPONENT ACCESS</b> .....	4-1
Component Locations .....	4-1
Removing The Cabinet .....	4-2
Removing The Bottom Cover & Hood Lamp Socket .....	4-3
Removing Cavity Thermostat 1 & The Humidity Sensor .....	4-4
Removing The Stirrer Motor .....	4-6
Removing Cavity Thermostats 2 & 3 .....	4-8
Removing The Hood Exhaust Fan Motor .....	4-10
Removing The Cavity Lamp & Socket .....	4-11
Removing The Control Panel Assembly, The Power Supply & Display Boards, And The Keyboard .....	4-12
Removing An Inline Fuse .....	4-14
Removing The AC Line Filter Capacitor .....	4-15
Removing The Cooling Fan Motor, The Exhaust Fan Thermostat, And The Line Fuseholder .....	4-16
Removing The Motor Capacitor, The Magnetron Thermostat, & The 40 W Inverter Board .....	4-18
Removing The 1100 W Inverter Board .....	4-20
Removing The Magnetron .....	4-22
Removing The Primary & Secondary Interlock Switches, And The Monitor Switch .....	4-24
Removing The Turntable Motor .....	4-26
Removing The Oven Door And The Inner Panel .....	4-27

<b>COMPONENT TESTING</b> .....	5-1
Door Switches .....	5-1
Touch Panel Continuity .....	5-2
Stirrer & Turntable Motors .....	5-3
AC Line Filter Capacitor .....	5-3
Humidity Sensor .....	5-4
Cavity Thermostats 1, 2, & 3 .....	5-4
Line Fuse & Exhaust Fan Thermostat .....	5-5
Motor Capacitor .....	5-5
Cooling Fan Motor .....	5-6
Hood Exhaust Fan Motor .....	5-6
Magnetron .....	5-7
Magnetron Thermostat .....	5-7
Inverters .....	5-8
 <b>DIAGNOSIS &amp; TROUBLESHOOTING</b> .....	 6-1
Power Output Measurement .....	6-1
Failure Codes .....	6-1
Display And Power Board Callouts .....	6-2
Primary, Secondary, & Monitor Switch Checks .....	6-3
Touch Panel & Microcomputer Board Test .....	6-4
 <b>WIRING DIAGRAMS &amp; STRIP CIRCUITS</b> .....	 7-1
Schematic Diagram .....	7-1
Wiring Diagram .....	7-2
Strip Circuits .....	7-3

# GENERAL

## WARNING TO SERVICE TECHNICIANS

To avoid possible exposure to microwave radiation or energy, visually check the oven for damage to the door and door seal before operating any oven. Use a microwave survey meter to check the amount of leakage before servicing. In the event the R.F. leakage exceeds  $4 \text{ mw/cm}^2$  at 5 cm, appropriate repair must be made before continuing to service the unit. Check interlock function by operating the door latch. The oven cook cycle should cut off before the door can be opened.

The door and latching assembly contains the radio frequency energy within the oven. The door is protected by three safety interlock switches. Do not attempt to defeat them.

**Under no circumstances should you try to operate the oven with the door open.**

- Proper operation of microwave ovens requires that the magnetron be properly assembled to the waveguide and cavity. Never operate the magnetron unless it is properly installed.
- Be sure the "RF" seal is not damaged and is assembled around the magnetron dome properly when installing the magnetron.
- Routine service safety procedures should be exercised at all times.
- Untrained personnel should not attempt service without a thorough review of test procedures and safety information contained in this Job Aid.

KitchenAid microwave ovens have a monitoring system designed to assure proper operation of the safety interlock systems.

The monitor switch will immediately cause the oven fuse to blow if the door is opened and the primary door interlock switch and/or the secondary interlock switch contacts fail in a closed position.

**CAUTION: Replace a blown fuse with a 20 ampere class H fuse only.**

Test the upper and lower door interlock switches, cook relay, and monitor switch (middle switch) for proper operation as described in the component test procedures, before replacing the blown oven fuse.

**Do not attempt to repair sticking contacts of any interlock switch, safety switch, or Cook (Latch) relay. The components must be replaced.**

Any indication of sticking contacts during component tests requires replacement of that component to assure reliability of the safety interlock system.

**If the fuse is blown, the Monitor switch, and the Primary, and Secondary interlock switches must be replaced. Be sure they are properly connected.**

# **PRECAUTIONS TO BE OBSERVED BEFORE AND DURING SERVICING TO AVOID POSSIBLE EXPOSURE TO EXCESSIVE MICROWAVE ENERGY**

- A. Do not operate or allow the oven to be operated with the door open.
- B. Make the following safety checks on all ovens to be serviced before activating the magnetron or other microwave source, and make repairs as necessary:
  - 1) Interlock Operation
  - 2) Proper Door Closing
  - 3) Seal and Sealing Surfaces (Arcing, Wear, and Other Damage)
  - 4) Damage to or Loosening of Hinges and Latches
  - 5) Evidence of Dropping or Abuse
- C. Before turning on the microwave power for any service test or inspection within the microwave generating components, check the magnetron, wave guide or transmission line, and cavity for proper alignment, integrity, and connections.
- D. Any defective or misadjusted components in the interlock, monitor, door seal, and microwave generation and transmission systems shall be repaired, replaced, or adjusted, using procedures described in this Job Aid, before the oven is released to the owner.
- E. A microwave leakage check to verify compliance with the Federal Performance Standard should be performed on each oven prior to release to the owner.
- F. Do not attempt to operate the oven if the door glass is broken.

# R.F. LEAKAGE TEST

## EQUIPMENT

- Electromagnetic energy leakage monitor (NARDA 8100B, HOLADAY H 1501 ).
- 275 ±15 ML glass beaker.

## TEST

On every service call, checks for microwave energy emission must be made according to the following manner.

1. Remove the cooking rack from the oven cavity, if the microwave oven is so equipped.
2. Place a 275 ±15 ML (9.3 oz.) glass of water in the center of the oven bottom.
3. Select "HIGH" cook power, turn the microwave oven on, and test for R.F. leakage at the following locations:
  - a) Around the cabinet at the front.
  - b) Around the door.
  - c) Across the console panel.
  - d) Horizontally across the door.
  - e) Vertically across the door.
  - f) Diagonally across the door.
  - g) Across the air vents.
  - h) Across the rear air vent.
  - i) All lockseams.
  - j) Weld at bottom.
  - k) Bottom plate.
  - l) Oven feet.
4. The scan speed is one inch per second.

When checking for R.F. leakage, use an approved R.F. measuring device to assure less than 4 mw/cm<sup>2</sup> emission at 5 cm distance with a maximum scan rate of 2.54 cm/second, in compliance with U.S. Government Department of Health, Education and Welfare 21CFR1030, Performance Standard for Microwave Ovens.

A properly operating door and seal assembly will normally register small emissions, but they must be no greater than 4 mw/cm<sup>2</sup> to allow for measurement uncertainty.

**NOTE:** Enter leakage readings in space BEFORE and AFTER on the service document.

All microwave ovens exceeding the emission level of 4 mw/cm<sup>2</sup> must be reported to Dept. of Service for Microwave Ovens immediately and the owner should be told not to use the microwave oven until it has been repaired completely.

If a microwave oven is found to operate with the door open, report to Dept. of Service, the manufacturer and CDRH\* immediately. Also tell the owner not to use the oven.

The monitor switch acts as the final safety switch protecting the customer from microwave radiation. If the monitor switch operated to blow the fuse when the interlocks failed, you must replace all interlock switches with new ones, because the contacts of those interlock switches may be melted and welded together.

If safety interlock/monitor switch replacement, or adjustment, is required, you must reconnect the circuit, and perform a continuity check on the monitor circuit.

All repairs must be performed in such a manner that microwave energy emissions are minimal.

Address for CDRH is:

**Office of Compliance (HFZ-312) Center for  
Devices and Radiological Health  
1390 Piccard Drive  
Rockville, MD 20850**

\* CDRH: Center for Devices and Radiological Health, Food and Drug Administration.

# PRECAUTIONS TO BE OBSERVED WHEN TROUBLESHOOTING

The microwave oven is a high voltage, high current appliance. It is free from danger during ordinary use, but extreme care should be taken during repair.

## CAUTION

Service technicians should remove their watches whenever working close to or replacing the magnetron.

## DANGER

### HIGH VOLTAGE AND HIGH TEMPERATURE (HOT/LIVE) OF THE INVERTER POWER SUPPLY

The high voltage inverter power supply circuit supplies very high voltage and very high current for the magnetron tube. Though it is free from danger in ordinary use, extreme care should be taken during repair. The current is extremely large, and so danger exists because of its high current and high voltages.

The aluminum heat sink is also energized with high voltage (HOT), so do not touch it when the AC input terminal is connected to the power line. One of the IGBT switching power devices (collector) is directly connected to the aluminum heat sink.

The aluminum heat sink may be HOT from heat energy; therefore, extreme care should be taken during servicing and replacing.

## WARNING

### INVERTER POWER SUPPLY GROUNDING

Check the high voltage inverter power supply circuit grounding. This high voltage inverter power supply circuit board must have a proper chassis ground by the grounding bracket to the chassis ground; otherwise, this H.V. inverter circuit board will expose very high voltage, and cause extreme DANGER. Be sure to have proper grounding by the grounding plate and screws.

## WARNING

### DISCHARGING HIGH VOLTAGE CAPACITORS

For about 30 seconds after the oven is turned off, an electric charge remains in the high voltage capacitors in the inverter power supply circuit board.

When replacing or checking parts, remove the power plug from the outlet. Use a screwdriver with an insulated handle, and short the inverter output of the magnetron filament terminals to discharge it. Be sure to touch the chassis ground side first, and then touch the output terminals.

## WARNING

There is high voltage present, with high current capabilities in the circuits of the primary and secondary windings, the choke coil, and the heat sink of the inverter. It is extremely dangerous to work on or near these circuits with the microwave oven energized. DO NOT measure the voltage in the high voltage circuit, including the filament voltage of the magnetron.

## WARNING

Never touch any circuit wiring with your hand, or with an insulated tool during operation.

## WARNING

Never insert a wire, nail, or any other metal object through the lamp holes on the cavity, or any other holes or gaps. Doing so may act as an antenna, and cause microwave leakage.

## WARNING

Before touching any oven components or wiring, always unplug the oven from its power source, and discharge the capacitors in the high voltage inverter.



# MODEL & SERIAL NUMBER DESIGNATIONS

## MODEL NUMBER

<b>MODEL NUMBER</b>		<b>K</b>	<b>HM</b>	<b>S</b>	<b>17</b>	<b>5</b>	<b>M</b>	<b>WH</b>	<b>0</b>
<b>PRODUCT GROUP</b>	K = KITCHENAID BRAND								
<b>PRODUCT IDENTIFICATION</b>	CM = COUNTERTOP MICROWAVE HM = MICROWAVE HOOD								
<b>MERCHANDISING SCHEME</b>	S = STANDARD C = MICRO-CONVECTION								
<b>CAPACITY / SIZE / SERIES / CONFIGURATION</b>	08 = 0.8 CU FT 10 = 1.0 CU FT 13 = 1.3 CU FT 14 = 1.4 CU FT 17 = 1.7 CU FT								
<b>FEATURES</b>	2 = PLUS FEATURES 5 = DELUXE FEATURES 6 = MICRO-CONVECTION 7 = MICRO-CONVECTION WITH SENSOR								
<b>YEAR OF INTRODUCTION</b>	M = 2003								
<b>COLOR CODE</b>	WH = WHITE, BL = BLACK, BT = BISCUIT, SS = STAINLESS STEEL								
<b>ENGINEERING CHANGE (0, 1, 2, ETC.)</b>									

## SERIAL NUMBER

<b>SERIAL NUMBER</b>	<b>TR</b>	<b>P</b>	<b>40</b>	<b>10007</b>
<b>MANUFACTURING SITE</b>	TR = Oxford, MS / Shunde			
<b>YEAR OF PRODUCTION</b>	P = 2003			
<b>WEEK OF PRODUCTION</b>	40TH WEEK			
<b>PRODUCT SEQUENCE NUMBER</b>				

# MODEL & SERIAL NUMBER LABEL AND TECH SHEET LOCATIONS

The Model/Serial Number label and Tech Sheet locations are shown below.



**Model & Serial  
Number Label Location**



**Tech Sheet  
Location  
(Behind Grille)**

# SPECIFICATIONS

MODEL	KHMS175M
<b>Colors</b>	White, Black, Biscuit , Stainless
<b>CONTROL SYSTEM</b>	Sensor
Type	Electronic
Limits	99 Min. 99 Sec.
Scale	Linear (Digital)
Display	2 Line Display with Multicolor Progress Bar 5+2 Digit - Blue-Green Fluorescent - Callouts In Display
In-Use Reprogramming	Yes
More/Less Function	Yes - Hidden "Cook Power" Button
Sales Demonstration Mode	Yes - Hidden
Keypad Disable / Child Lockout Mode	Yes - Press "Off/Cancel" Key for 5 Seconds
<b>Cook Power</b>	Yes
Type	Electronic
Range	0% - 100%
Scale	Digital
Levels	Ten
<b>Exhaust Fan</b>	
Number of Speeds	5
Manual Off	Yes
Auto Off	No
Automatic Turn On @	60°C, 140°F
Cooktop Light	Halogen
Settings	3 levels HIGH, NIGHT & LOW
Wattage	(2) 10 Watt Halogen
Light Cover	Glass
Light "ON" When Cook Cycle Complete	Yes
Stoppable Turntable Function / Button	Yes
Technical Error Indication	"F-" With Error Number
<b>OVEN INTERIOR FEATURES</b>	
Size (inches)	22 7/8" W x 9 1/2" H x 14 1/2" D
Cooking Power	1100 Watts (IEC-705 Rating)
Turntable	Yes, Sunken Flush
Glass turntable diameter	12"
Browning Pan	Yes
Ventilation	Axial blower
Cooling Fan	Automatic - On if oven is operating, Off if door open
Rack	Yes
Light	Automatic - Turns on when oven door is open or oven is operating. 10 Watt Halogen

<b>MODEL</b>	<b>KHMS175M</b>
<b>DOOR FEATURES</b>	
Handle/Latch	Yes/Pull to open
Seals	Two Stage (Capacitive and Reflective)
<b>MICROWAVE SYSTEM</b>	
Distribution	Top Feed with Stirrer
Magnetron	Inverter Type
<b>SAFETY FEATURES</b>	
Interlock	Three Door/Latch Operated Primary, secondary and monitor
Thermal Protectors	Three - 1 Magnetron, 1 Oven Cavity, 1 Hood
<b>VENTILATION SYSTEM</b>	
Type	Convertible Recirculation or Exhaust Vertical/Horizontal
Duct Outlet Size	3 1/4"H x 10"W
Recirculation CFM Out	130
Exhaust CFM Out	175
Touch Control	5 Speed
Auto ON - High Speed	YES: 60°C, 140°F
Noise Level Recirculation (Acc. to IEC 704)	67dBA
Shipped	Recirculation mode
<b>EXTERIOR FEATURES</b>	
Power Cord Length	3 Feet
<b>OTHER SPECIFICATIONS</b>	
Electrical	120V, Single Phase, 60 Hz 1500 Watts, For Use With 15 - 20 Amp Circuit
Domestic Use Only	Yes
Agency Approvals	FCC, DHHS, CDRH, UL
Approx. Net Weight - Lb	63
<b>APPROVED ACCESSORIES</b>	
Crisp Pan	Yes
Exhaust Damper Assembly	Yes (1 Set)
Hardware for Installation	Yes (1 Set)
<b>LITERATURE</b>	
Use & Care Guide	Yes (Browning Pan instructions included)
Warranty	In Use & Care Guide-1 Yr. Full, 2-5 Yr. Ltd. Mag. Tube
Tech Sheet	8185202
Job Aid	4317357

# KITCHENAID MICROWAVE OVEN WARRANTY

LENGTH OF WARRANTY:	KITCHENAID WILL PAY FOR:	KITCHENAID WILL NOT PAY FOR:
<p><b>ONE-YEAR FULL WARRANTY</b> From Date of Purchase.</p>	<p>Replacement parts and repair labor costs to correct defects in materials or workmanship. Service must be provided by a KitchenAid-designated servicing company.</p>	<p>A. Service calls to:</p> <ol style="list-style-type: none"> <li>1. Correct the installation of the microwave oven.</li> <li>2. Instruct you how to use the microwave oven.</li> <li>3. Replace house fuses or correct house wiring.</li> <li>4. Replace owner-accessible light bulbs.</li> </ol> <p>B. Repairs when microwave oven is used in other than normal single-family household use.</p>
<p><b>LIMITED FOUR-YEAR WARRANTY</b> Second through fifth year from Date of Purchase.</p>	<p>Replacement magnetron tube on microwave ovens if defective in materials or workmanship.</p>	<p>C. Pickup and delivery. The microwave is designed to be repaired in the home.</p> <p>D. Damage to the microwave oven resulting from accident, alteration, misuse, abuse, fire, flood, acts of God, or use of products not approved by KitchenAid.</p> <p>E. Any labor costs during the limited warranty.</p> <p>F. Repairs to parts or systems resulting from unauthorized modifications made to the appliance.</p> <p>G. Replacement parts or repair labor costs for units operated outside the United States.</p>

**KITCHENAID OR KITCHENAID CANADA DO NOT ASSUME ANY RESPONSIBILITY FOR INCIDENTAL OR CONSEQUENTIAL DAMAGES.** Some states or provinces do not allow the exclusion or limitation of incidental or consequential damages, so this exclusion or limitation may not apply to you. This warranty gives you special legal rights, and you may also have other rights which vary from state-to-state or province-to-province.

**Outside the United States and Canada, a different warranty may apply. For details, please contact your authorized KitchenAid dealer.**

If you need service first see the "Troubleshooting" section of the Use and Care Guide. After checking "Troubleshooting," additional help can be found by checking the "Assistance or Service" section, or by calling our Customer Interaction Center telephone numbers, listed below, from anywhere in the U.S.A. or Canada.

KitchenAid: **1-800-422-1230**  
Canadian Residents call: **1-800-807-6777**

— NOTES —

# INSTALLATION INFORMATION

## ADJUSTING THE EXHAUST AIRFLOW

1. Remove the screw from the damper plate on top of the microwave cabinet, and remove the plate from under the cabinet flanges.

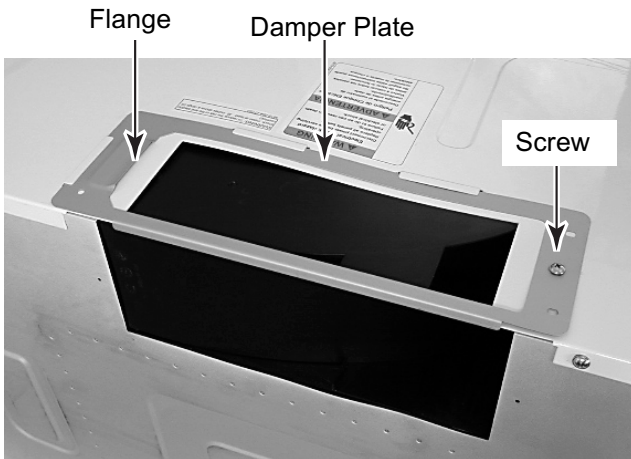

2. Slide the air deflector out of the cabinet.



3. Refer to the following illustrations and determine how you would like to direct the exhaust air out of the microwave oven.  
**NOTE:** All microwave ovens are shipped with the venting in the "recirculating" mode.

### Recirculating Air

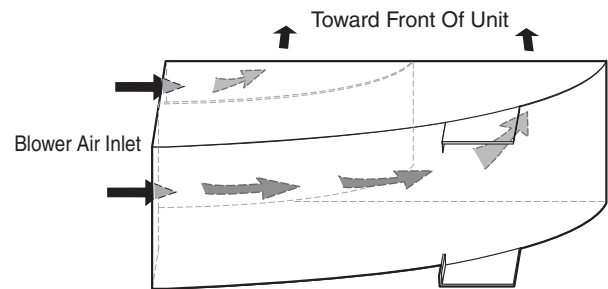

### Rear Venting

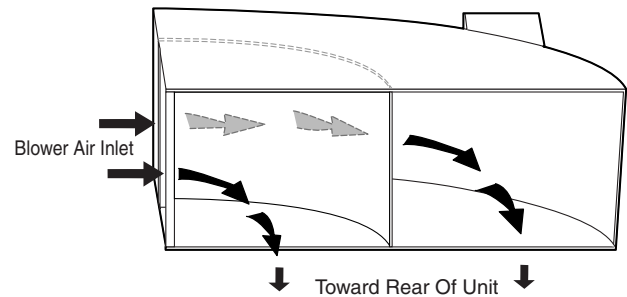

### Top Venting

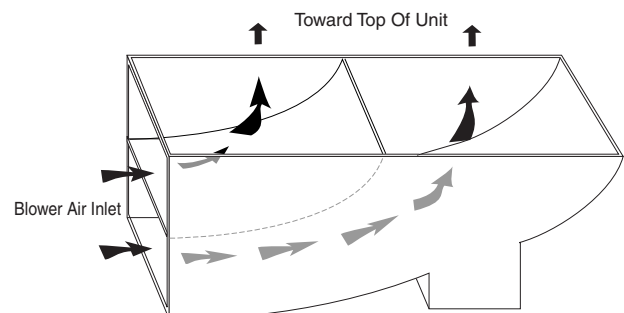

4. Rotate the air deflector so that the vanes face in the desired direction, and slide the air deflector back into the cabinet as far as it will go, then reinstall the damper plate.

# REMOVING & REINSTALLING THE MICROWAVE OVEN

To remove the microwave oven:

1. Unplug the microwave oven or disconnect the power.
2. Open the microwave oven door.
3. Pull the top of the air grille forward to release the clips, then lift the grille, and remove the bottom tabs from the cabinet slots.

Pull Top Of Air Grille Forward

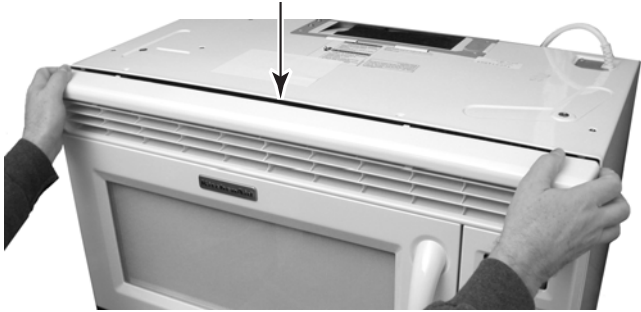

4. Remove the turntable and roller assembly.
5. Tape the door closed.

**CAUTION: Use two people to support the microwave oven when you remove it from its mounting location.**

6. Remove the two bolts that secure the microwave oven to the upper cabinet.
7. Hold the microwave oven in place with one hand, and pull the latching arm forward to release the latch from the rear mounting plate clip.

Pull Latching Arm

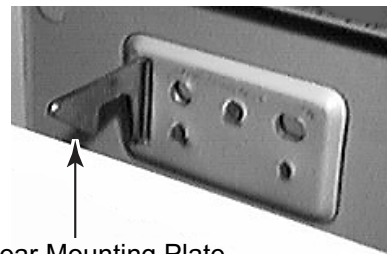
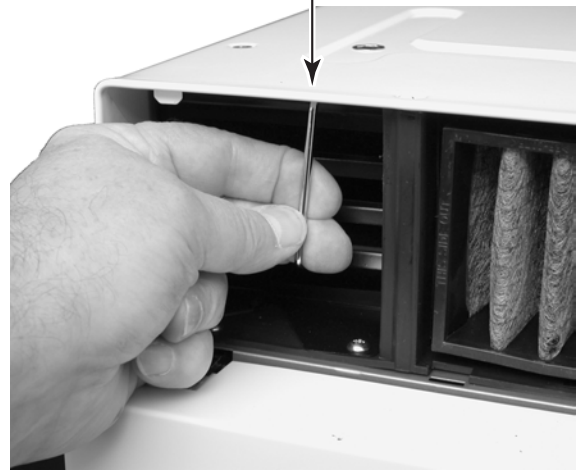

Clip On Rear Mounting Plate

Latch Engaged

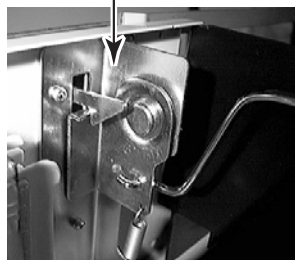

Latch Released





8. Rotate the microwave oven downward, and lift the oven to unhook it from the bottom of the mounting plate. Set the oven on a protected surface.

Mounting Plate Hook

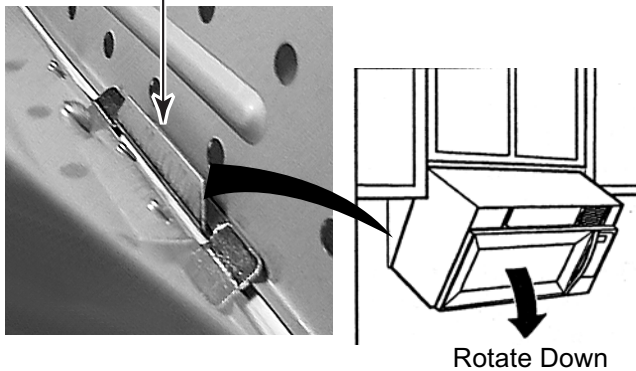

To reinstall the microwave oven:

1. Carefully lift the microwave oven and hang it on the mounting plate hooks.
2. Rotate the front of the microwave oven cabinet downward and insert the power supply cord through the hole in the bottom of the cabinet.
3. Rotate the microwave oven towards the cabinet and push the oven against the mounting plate until the clip snaps into the cabinet.
4. Install the two bolts that secure the microwave oven to the upper cabinet.
5. Install the air grille.
6. Remove the tape from the door and replace the turntable and roller assembly.
7. Plug in the microwave oven.

— NOTES —

# THEORY OF OPERATION

## MICROWAVE OPERATION

Traditional microwave technology is only able to generate microwave energy at full power. In order to reduce the power when cooking, defrosting, or reheating food, the microwave cycles on and off, intermittently heating the food at full power, so that the food is still heated with full power, but for less time. This makes it difficult to achieve slow, or simmer-type cooking.

A microwave operates at full power whenever the magnetron is on. Reducing the power level only reduces the time that the magnetron is on.

50% Power Cycling On & Off  
(Old Technology)

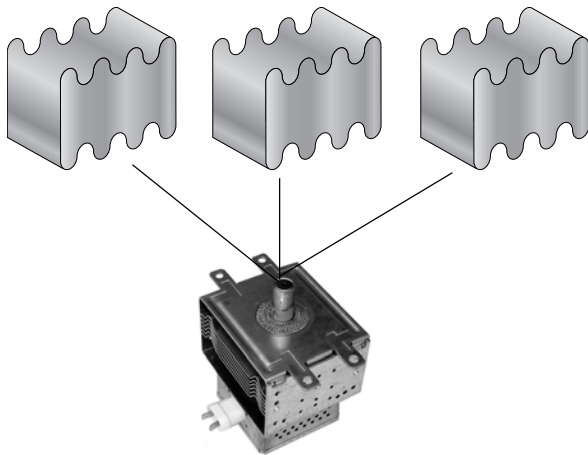

**Old Technology**

Power Level	Magnetron On	Magnetron Off
0	0 Seconds	24 Seconds
1	4 Seconds	20 Seconds
2	6 Seconds	18 Seconds
3	8 Seconds	16 Seconds
4	11 Seconds	13 Seconds
5	13 Seconds	11 Seconds
6	16 Seconds	8 Seconds
7	18 Seconds	6 Seconds
8	20 Seconds	4 Seconds
9	22 Seconds	2 Seconds
10	24 Seconds	0 Seconds

Newest developed technology has the ability to control the level of microwave energy. When cooking, defrosting, or reheating at reduced power levels, the food receives constant energy that is evenly dispensed, producing true slow, or simmer-type cooking.

50% Power On Continuously  
(New Technology)

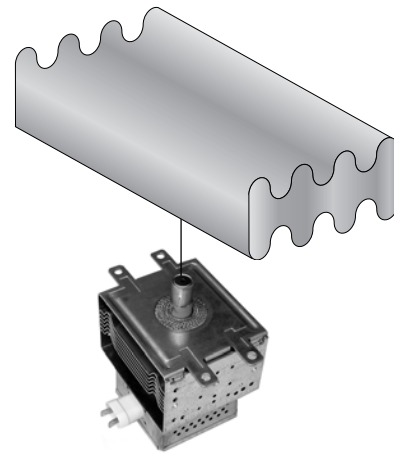

**New Technology**

Power Level	Magnetron On	Magnetron Off
0	0 Seconds	24 Seconds
1	24 Seconds	0 Seconds
2	24 Seconds	0 Seconds
3	24 Seconds	0 Seconds
4	24 Seconds	0 Seconds
5	24 Seconds	0 Seconds
6	24 Seconds	0 Seconds
7	24 Seconds	0 Seconds
8	24 Seconds	0 Seconds
9	24 Seconds	0 Seconds
10	24 Seconds	0 Seconds

The power for the new Over-The-Range Microwave Oven is produced by 40 Watt and 1100 Watt inverters.

The 40 Watt inverter provides 12 volts DC to operate the cooling fan and cavity lights.

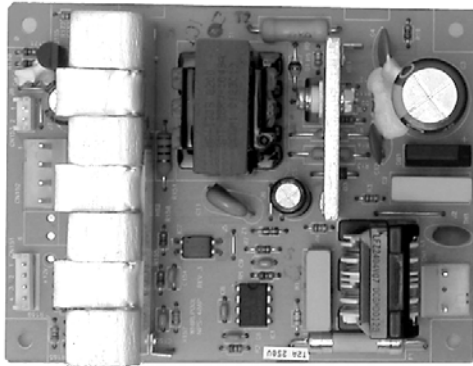

**40 W INVERTER**

(Supplies 12 VDC To Cooling Fan & Cavity Lights)

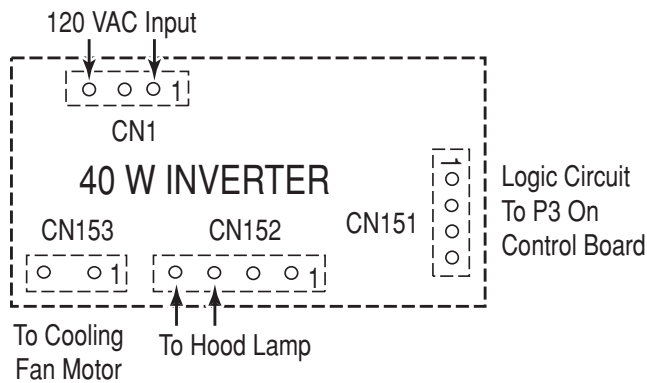

**40 W INVERTER CONNECTORS**

The 1100 Watt inverter replaces the high voltage transformer, capacitor, and diode to provide the necessary power to operate the magnetron.



**1100 W INVERTER**

(Replaces The High Voltage Transformer, Capacitor, & Diode)

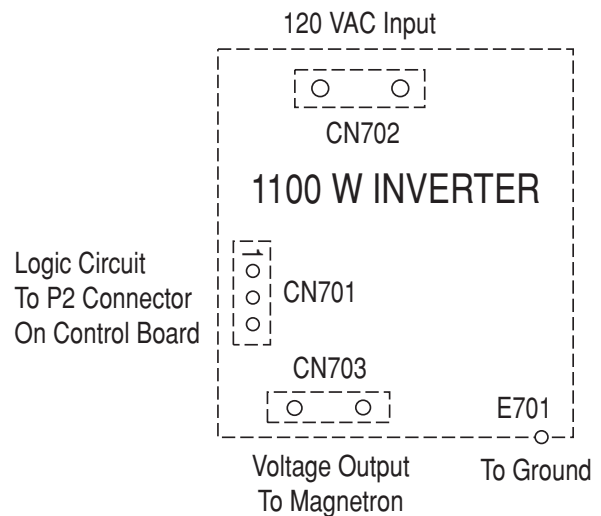

**1100 W INVERTER CONNECTORS**

# COMPONENT ACCESS

This section instructs you on how to service each component inside the Over-The-Range Microwave Oven. The components and their locations are shown below.

## COMPONENT LOCATIONS

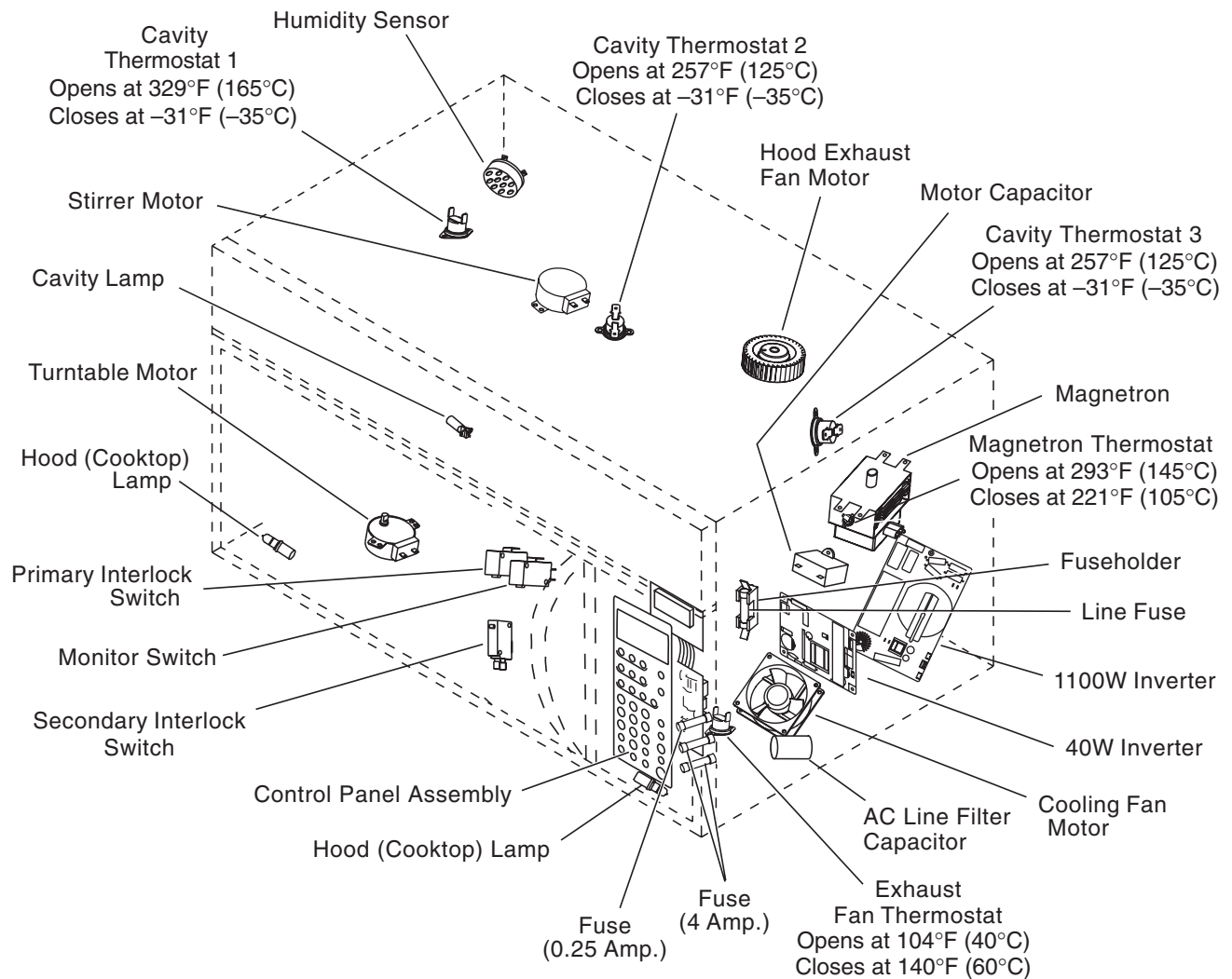

## REMOVING THE CABINET

### ⚠ WARNING



**Electrical Shock Hazard**  
Disconnect power before servicing.  
Replace all parts and panels before operating.  
Failure to do so can result in death or electrical shock.

1. Unplug microwave oven or disconnect power.
2. Remove the microwave oven from its mounting location (see page 2-2 for the procedure).
3. Tip the oven on its rear panel and remove the two cabinet bottom screws (one on each side) from the bottom cover, then tip the unit to its upright position.

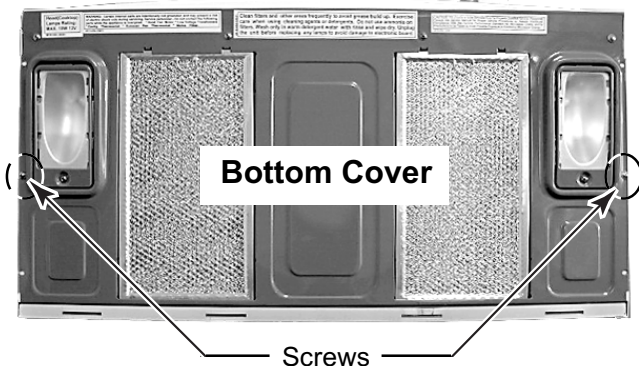

4. Remove the eight screws from the back of the unit.

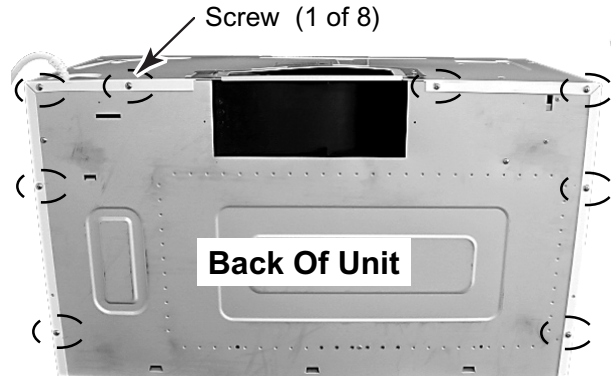

5. Remove the power cord cover screw and remove the cord cover.
6. Remove the six flat-head screws from the top of the cabinet.
7. Remove the air duct by pulling it out the back of the unit.
8. Pull the air filter forward and remove it.



9. Pull the cabinet back so that the two slots on each side unhook from the tabs of the front panel, and remove the cabinet from the oven.

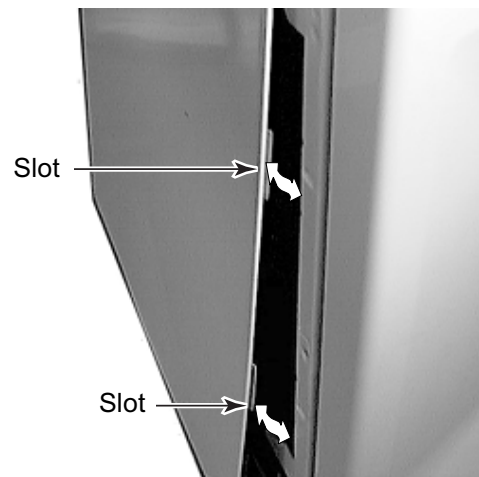

# REMOVING THE BOTTOM COVER & HOOD LAMP SOCKET

## ⚠ WARNING



**Electrical Shock Hazard**  
**Disconnect power before servicing.**  
**Replace all parts and panels before operating.**  
**Failure to do so can result in death or electrical shock.**

1. Unplug microwave oven or disconnect power.

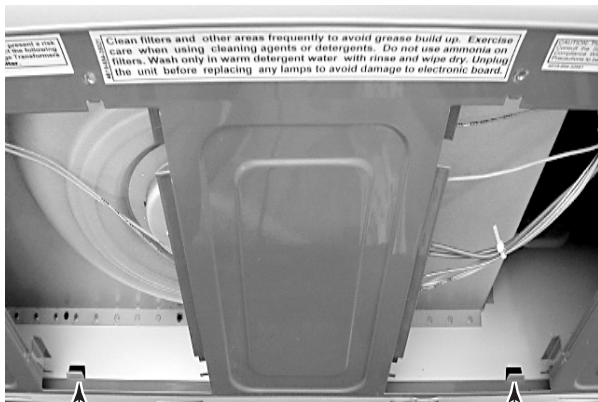

Lift The Rear Edge Of  
The Bottom Cover  
Away From Tabs

Light Shield    Lamp Socket

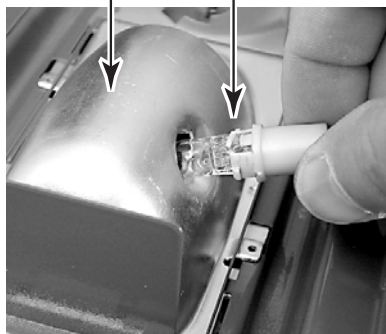

2. Remove the six screws from the bottom cover and lower the top edge of the cover.

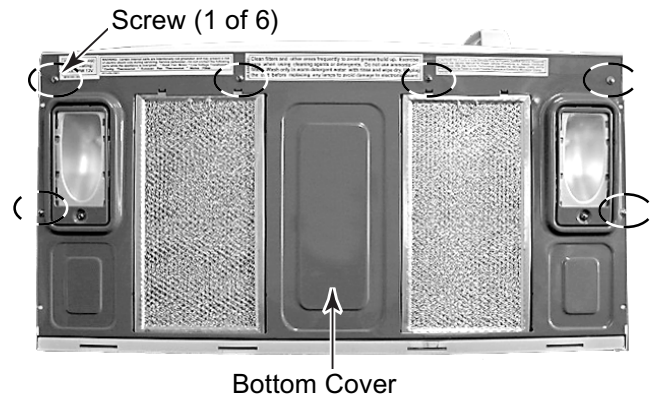

3. Disconnect the turntable motor connector and the lamp connector.
4. Lift the rear edge of the bottom cover away from the two tabs and lower the cover.
5. **To remove a hood lamp socket and lamp:**

- a) Twist the socket and align the two tabs with the hole slots, then pull the socket out of the light shield hole.
- b) Pull the pins of the lamp out of the socket holes.

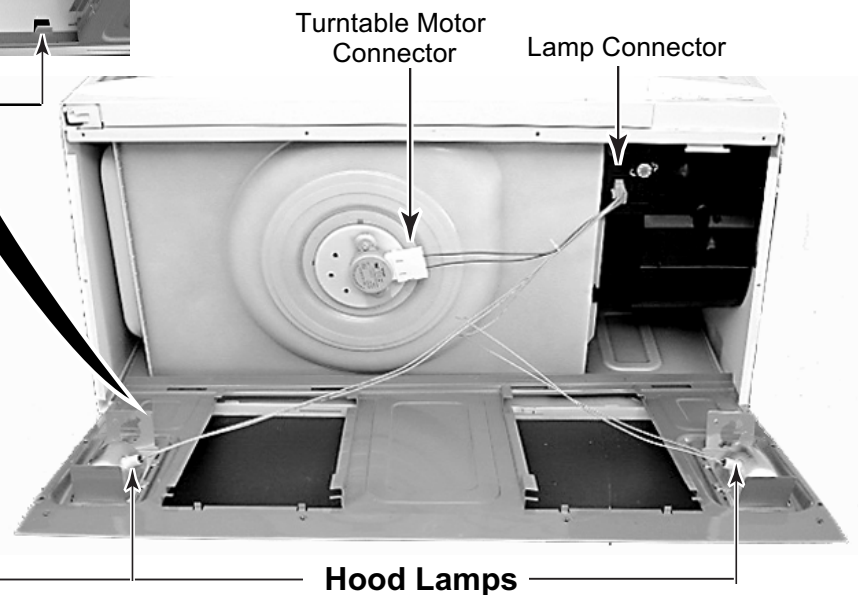

# REMOVING CAVITY THERMOSTAT 1 & THE HUMIDITY SENSOR

## ⚠ WARNING



### Electrical Shock Hazard

Disconnect power before servicing.

Replace all parts and panels before operating.

Failure to do so can result in death or electrical shock.

1. Unplug microwave oven or disconnect power.
2. Remove the cabinet (see page 4-2 for the procedure).

Cavity Thermostat 1 & Humidity Sensor

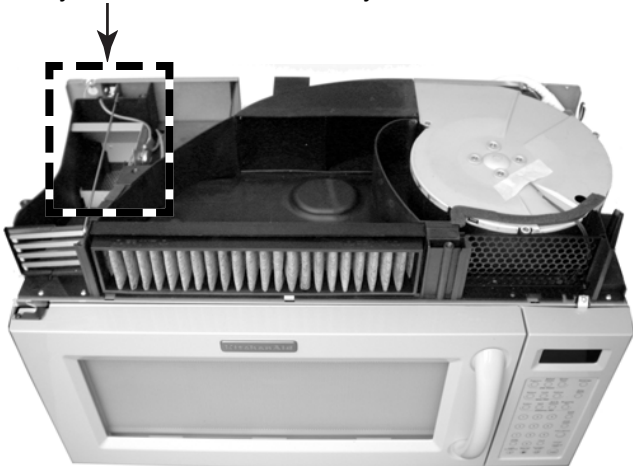

3. **To remove cavity thermostat 1:**
  - a) Disconnect the wires from the thermostat terminals.

- b) Press down on the locking tab in the holder and rotate the thermostat counterclockwise until it is free of the catches, then lift it from the holder.

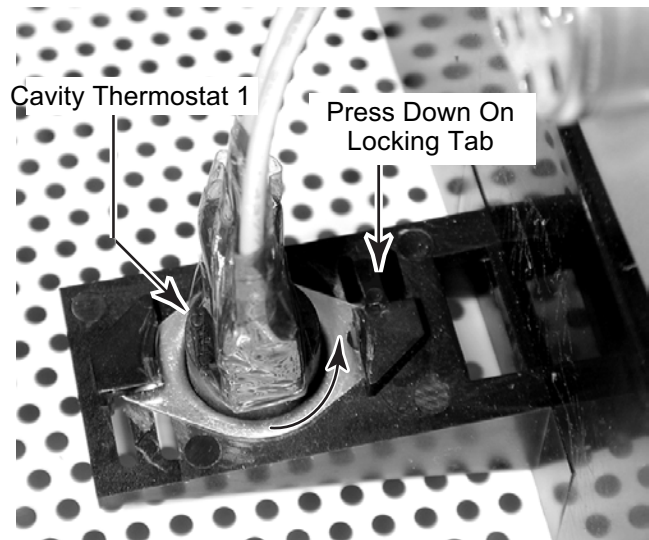

4. **To remove the humidity sensor:**

- a) Remove the top screw from the control panel, then lift the panel, unhook the side latching tabs, and tilt the top forward.

Control Panel Screw





- b) Disconnect the 3-wire (red, white, & black) sensor connector from display board connector P5.

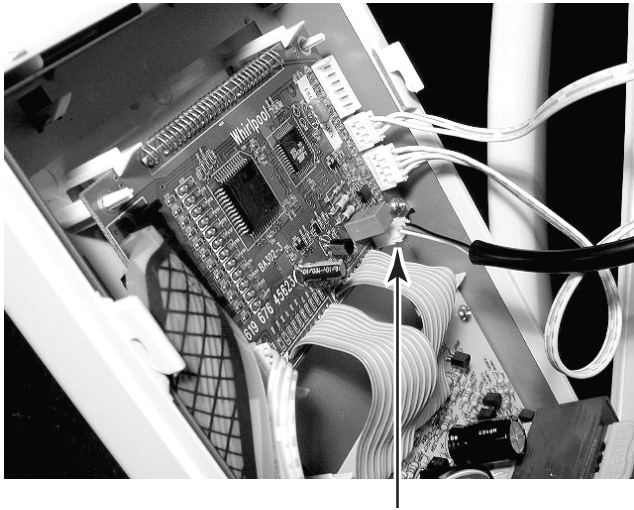

Humidity Sensor Connector (P5)

- c) Remove the two top cover screws from the rear panel.

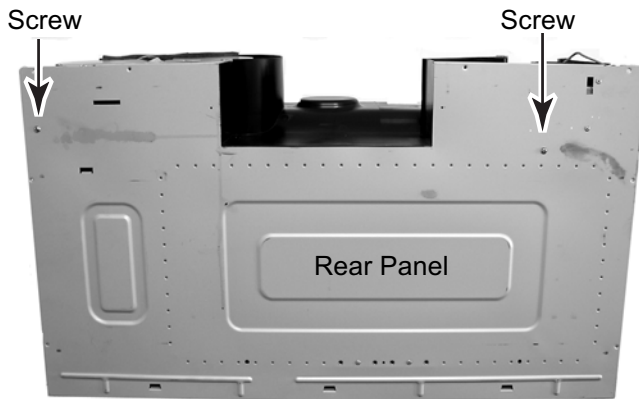

- d) Remove the three top cover screws from the front corners.

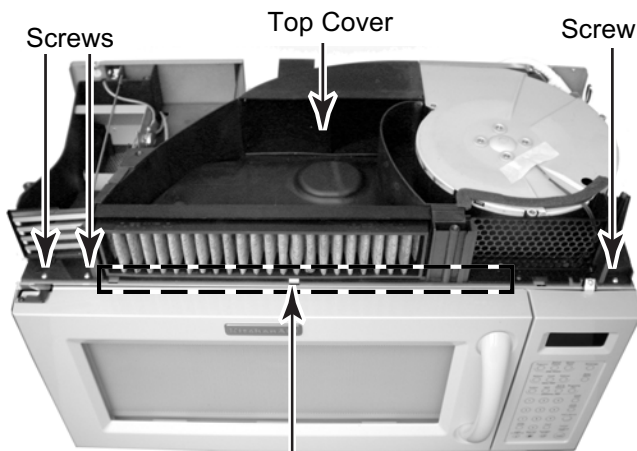

4 Front Top Cover Locking Tabs

- e) Remove the two screws and ground wire from the sensor and remove the sensor from the bracket.
- f) Slide the top cover to the left and unhook the four front locking tabs in the cover with the slots in the chassis, (see the lower left photo).
- g) Lift the top cover and pull the sensor cable through the access hole, and remove the sensor.

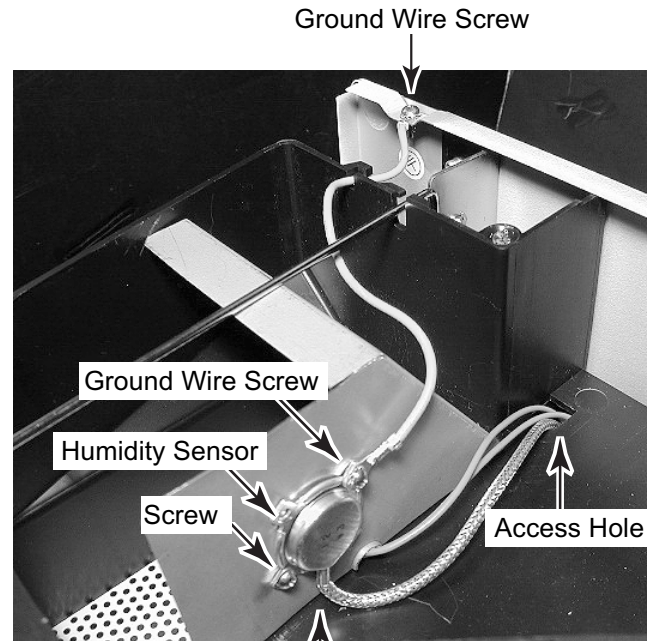

Position Humidity Sensor Cable Here

**REASSEMBLY NOTE:** When you reinstall the humidity sensor on the bracket, be sure to position the cable facing down, as shown in the photo.

**⚠ WARNING**

**Electrical Shock Hazard**

**Connect green ground wire to ground screw.**

**Failure to do so can result in death or electrical shock.**

## REMOVING THE STIRRER MOTOR

### ⚠ WARNING



#### Electrical Shock Hazard

Disconnect power before servicing.

Replace all parts and panels before operating.

Failure to do so can result in death or electrical shock.

1. Unplug microwave oven or disconnect power.
2. Remove the cabinet (see page 4-2 for the procedure).
3. Remove the three front and two rear top cover screws (see steps 4c and 4d on page 4-5).
4. Remove the humidity sensor ground wire screw from the rear panel.

Ground Wire Screw

Rear Panel

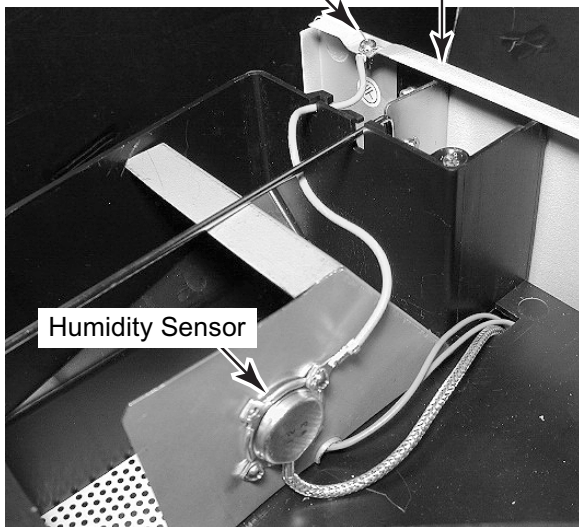

Humidity Sensor

5. Slide the top cover to the left and unhook the four front locking tabs in the cover with the slots in the chassis, (see photo in step 4d on page 4-5 for the tab locations).

6. Lift the left end of the top cover and prop it up so you can access the stirrer motor.

Stirrer Motor

Wires

Screw (1 of 2)

Raise & Prop Up Top Cover

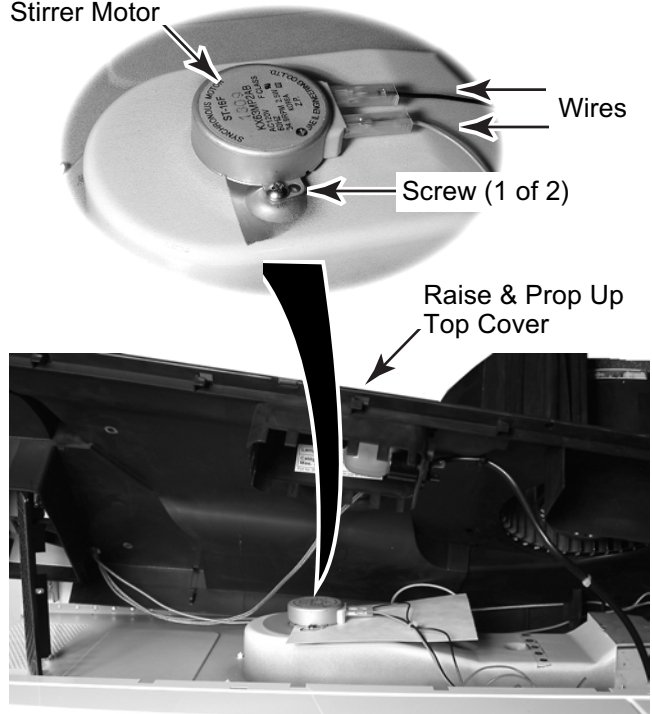

7. Remove the screws from the motor and disconnect the wire connectors from the motor terminals.
8. Open the microwave oven door.
9. Use a putty knife and pry the stirrer motor cover with the plastic nails and bushings off the top of the oven cavity.

Stirrer Motor Cover



10. Carefully pull the mica cover off the stirrer motor opening and remove the stirrer fan. **NOTE:** The cover is held in place with Selastic adhesive.
11. Use a piece of sandpaper and clean the adhesive and other debris from around the stirrer motor opening.

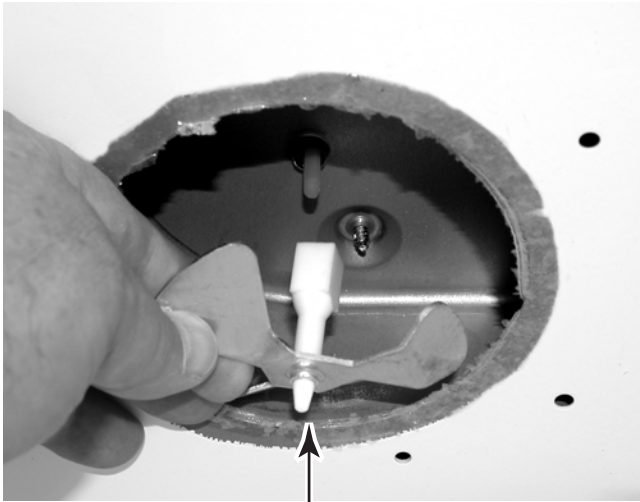

Stirrer Fan On Motor Shaft

Clean Around Opening

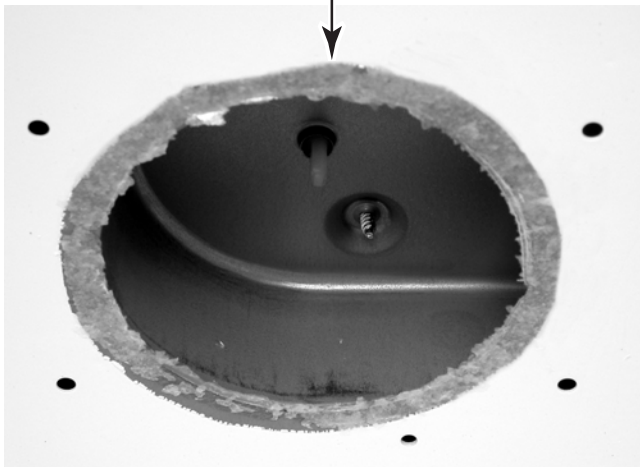

12. Install the new stirrer motor to the unit with the two screws you removed earlier, and connect the wires to the terminals.
13. Apply a 1/8" bead of Selastic around the unpainted area of the stirrer motor opening. Make sure that the bead goes completely around the opening with no breaks, so that a complete seal is made between the cover and the top of the oven cavity.
14. Install the stirrer fan onto the stirrer motor shaft as far as it will go.
15. Place the mica cover over the stirrer motor opening and align the four holes with those in the oven cavity. Press the cover firmly onto the adhesive, and install the four bushings and plastic nails in the holes.

## ⚠ WARNING



### Electrical Shock Hazard

Connect green ground wire to ground screw.

Failure to do so can result in death or electrical shock.

## REMOVING CAVITY THERMOSTATS 2 & 3

### ⚠ WARNING



#### Electrical Shock Hazard

Disconnect power before servicing.

Replace all parts and panels before operating.

Failure to do so can result in death or electrical shock.

1. Unplug microwave oven or disconnect power.
2. Remove the cabinet (see page 4-2 for the procedure).
3. Remove the three front and two rear top cover screws (see steps 4c and 4d on page 4-5).
4. Remove the humidity sensor ground wire screw from the rear panel (see step 4 on page 4-6).
5. Slide the top cover to the left and unhook the four front locking tabs in the cover with the slots in the chassis, (see photo in step 4d on page 4-5 for the tab locations).

6. Lift the front of the top cover so you can access cavity thermostats 2 and 3, and prop it up.

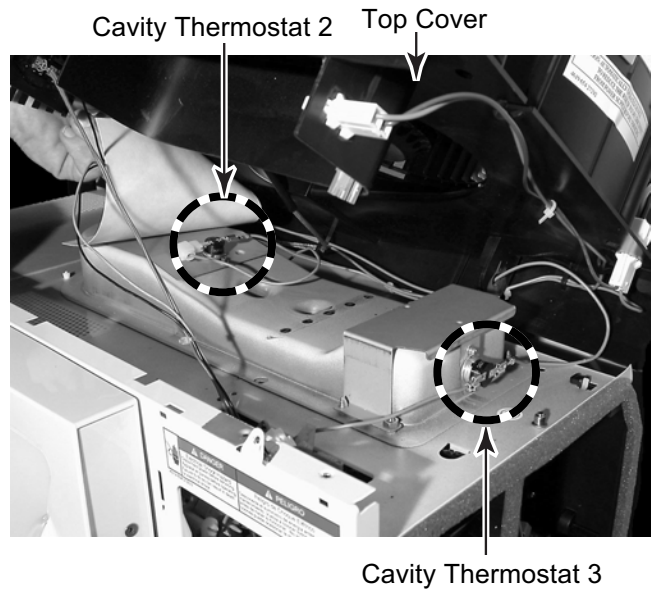

7. **To remove cavity thermostat 2:**
  - a) Fold back the paper insulator.
  - b) Remove the wires from the terminals.
  - c) Remove the two mounting screws.

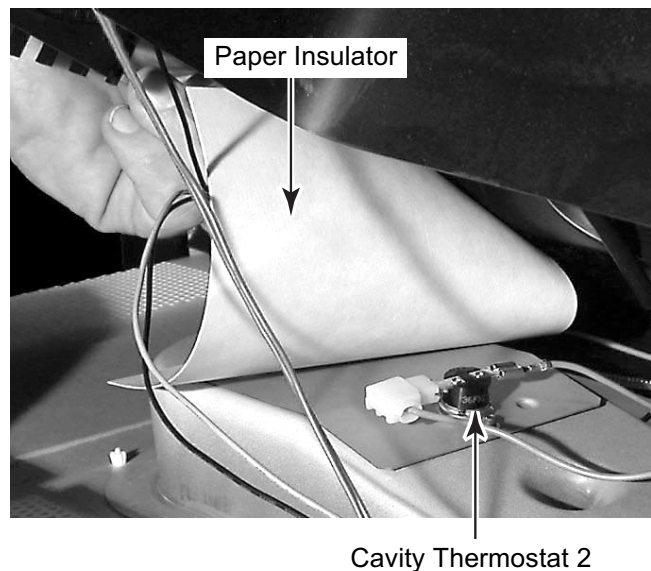

8. **To remove cavity thermostat 3:**
- a) Remove the wires from the terminals.
  - b) Remove the two mounting screws.

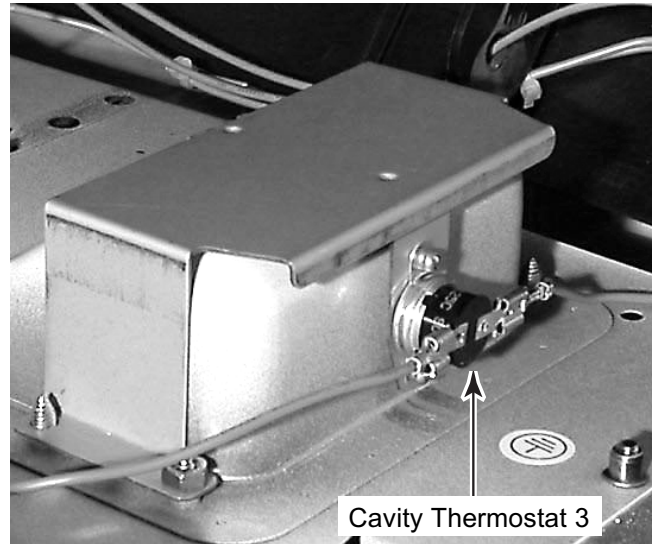

# REMOVING THE HOOD EXHAUST FAN MOTOR

## ⚠ WARNING



### Electrical Shock Hazard

Disconnect power before servicing.

Replace all parts and panels before operating.

Failure to do so can result in death or electrical shock.

1. Unplug microwave oven or disconnect power.
2. Remove the cabinet (see page 4-2 for the procedure).

Hood Exhaust Fan Motor



3. From the right side of the unit, disconnect the 3-wire (red, white & black) hood exhaust fan motor connector from the main harness connector.

Hood Exhaust Fan Motor Connector

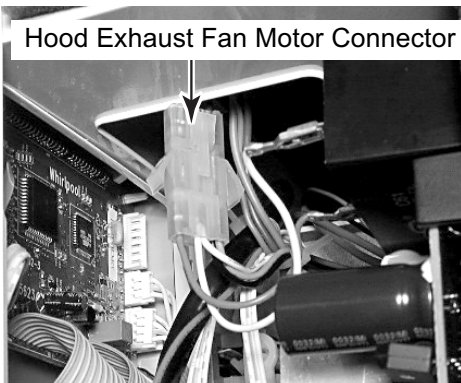

4. Remove the four hood exhaust fan motor cover screws.
5. Remove the four hood exhaust fan motor mounting screws and cup washers.

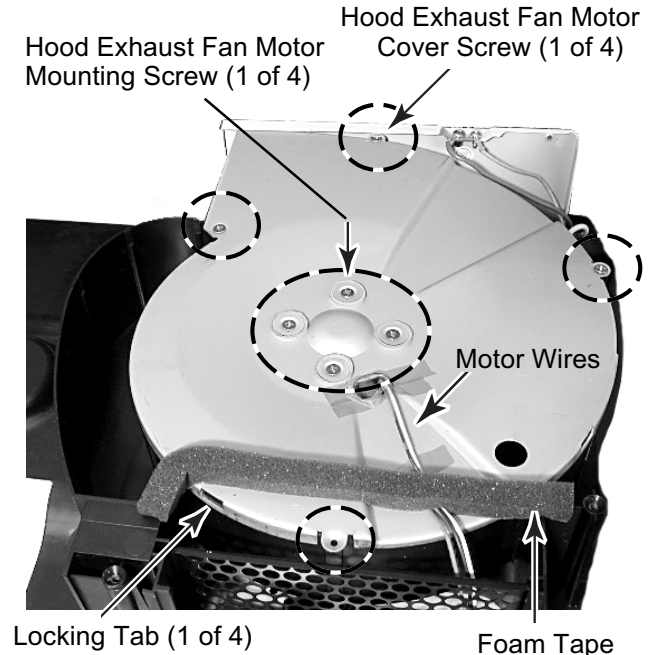

6. Carefully remove the tape from over the motor wires, then press in on the four locking tabs, and lift the cover off the hood exhaust fan motor.
7. Remove the hood exhaust fan motor.

Hood Exhaust Fan Motor



## REMOVING THE CAVITY LAMP & SOCKET

### ⚠ WARNING



#### Electrical Shock Hazard

Disconnect power before servicing.

Replace all parts and panels before operating.

Failure to do so can result in death or electrical shock.

1. Unplug microwave oven or disconnect power.
2. Open the microwave oven door.
3. Pull the top of the air grille forward to release the clips, then lift the grille, and remove the bottom tabs from the cabinet slots.

Pull Top Of Air Grille Forward



4. Lift the front of the cavity lamp cover slightly and pull it out of the slot in the top cover.

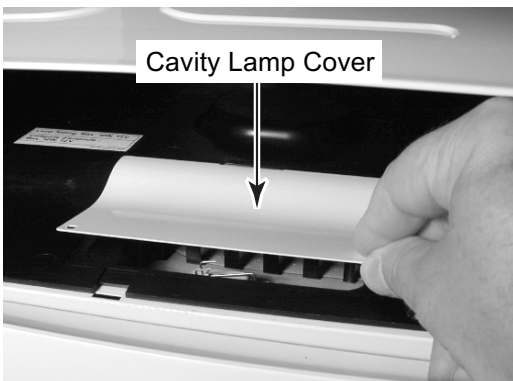

5. Unscrew the bulb from the cavity lamp socket.
6. To remove the cavity lamp socket, twist the socket to the left (counterclockwise) to unlock it, and push it out of the mounting hole.

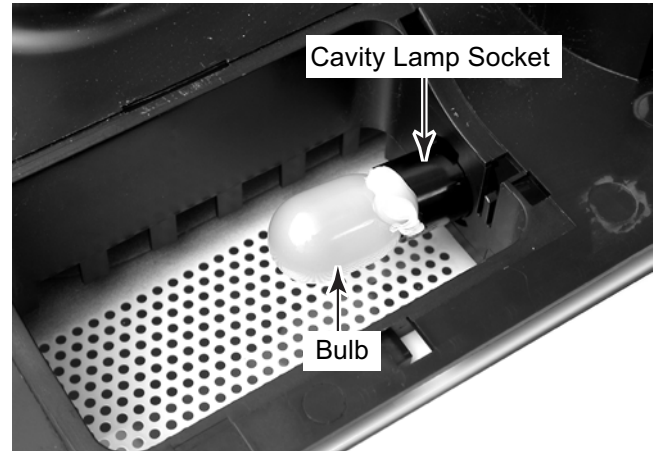

7. Disconnect the wires from the socket terminals.

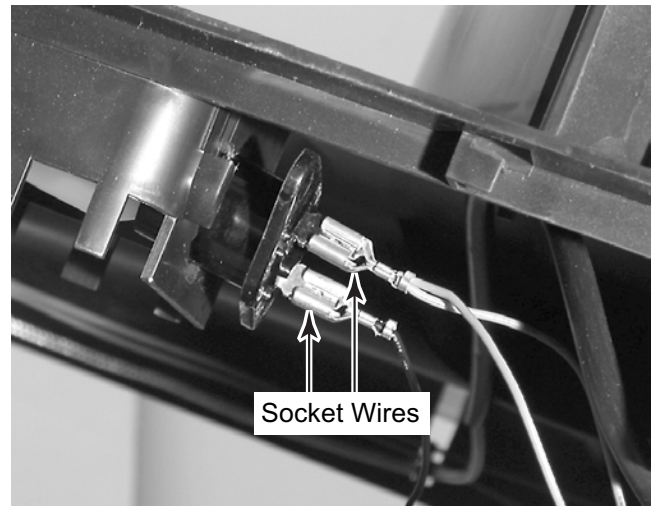

# REMOVING THE CONTROL PANEL ASSEMBLY, THE POWER SUPPLY & DISPLAY BOARDS, AND THE KEYBOARD

## ⚠️ WARNING



### Electrical Shock Hazard

Disconnect power before servicing.

Replace all parts and panels before operating.

Failure to do so can result in death or electrical shock.

1. Unplug microwave oven or disconnect power.
2. Remove the air grille from the unit (see page 4-11 for the procedure).
3. **To remove the control panel assembly:**
  - a) Remove the top screw from the control panel, then lift the panel, unhook the side latching tabs, and tilt the top forward as far as the wires will allow.

Control Panel Screw



- b) Disconnect wire connectors P2, P3, P5, P12, and P14 from the display and power supply boards.
- c) Disconnect the wires from the relay terminals.
- d) Remove the green ground wire from the control panel bracket.
- e) Unhook the hinge from the slot and remove the control panel assembly from the unit.
- f) Lay the control panel assembly on a padded surface.

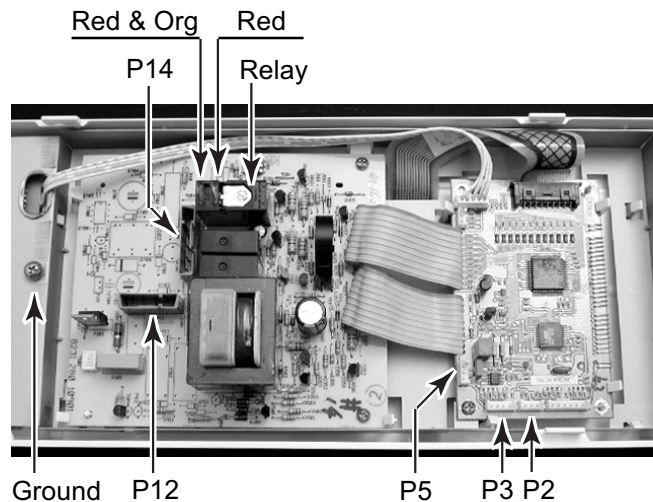

## ⚠️ WARNING



### Electrical Shock Hazard

Connect green ground wire to ground screw.

Failure to do so can result in death or electrical shock.



4. **To remove the power supply & display boards:**

- a) Disconnect wire connector P7 from the display board.
- b) Lift the locking arm by the two end tabs and remove the two ribbon cables from connector P6.
- c) Remove the screw from the display board and unclip it from the locking arms.
- d) Remove the two screws from the power supply board and unclip it from the locking arms.
- e) Remove the power supply and display boards from the control panel.

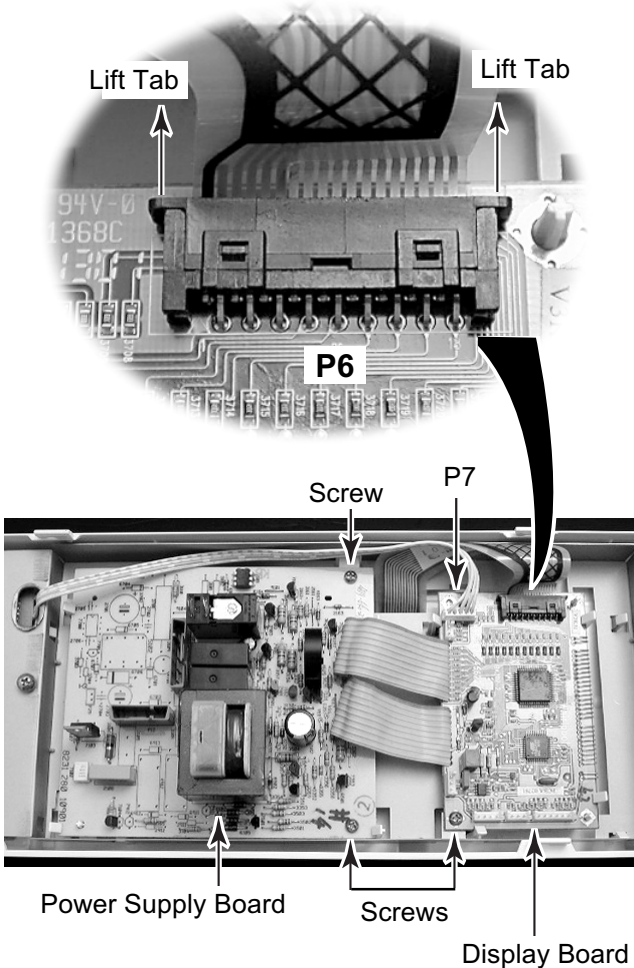

5. **To remove the keyboard:**

- a) Unclip the bracket and remove it from the panel.

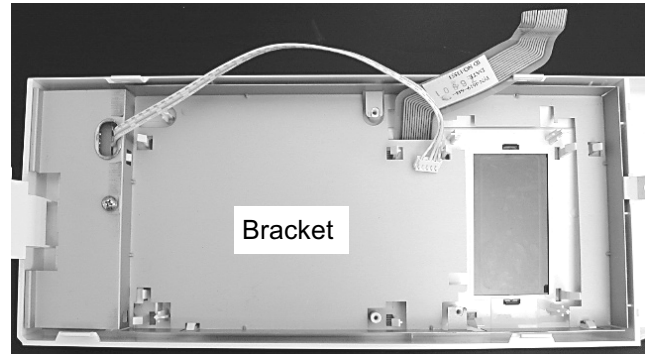

- b) Remove the two screws from the keyboard and unclip it from the panel.
- c) To replace the display window on the control panel, unclip the two tabs.

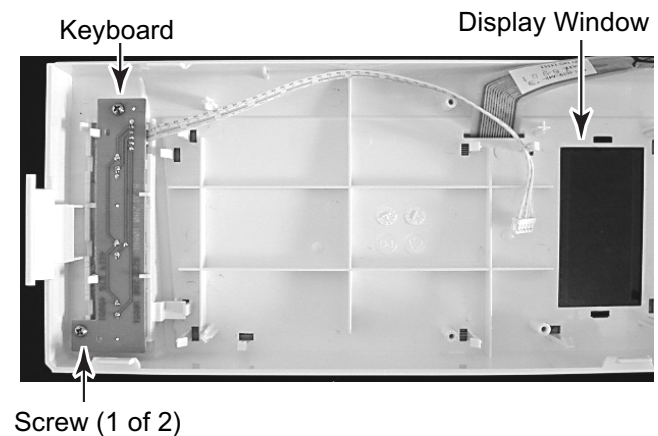

## REMOVING AN INLINE FUSE

### ⚠ WARNING



**Electrical Shock Hazard**  
**Disconnect power before servicing.**  
**Replace all parts and panels before operating.**  
**Failure to do so can result in death or electrical shock.**

1. Unplug microwave oven or disconnect power.
2. Remove the air grille (see page 4-11 for the procedure).
3. Open the microwave oven door.
4. Remove the control panel assembly (see page 4-12 for the procedure).
5. Determine which of the three inline fuses you need to remove.

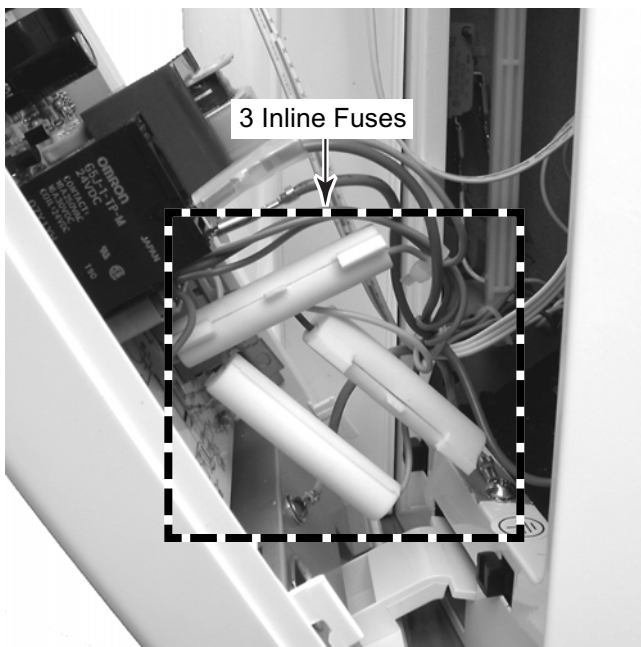

6. Unsnap the two tabs from the locking arms on the fuseholder for the inline fuse you are removing.

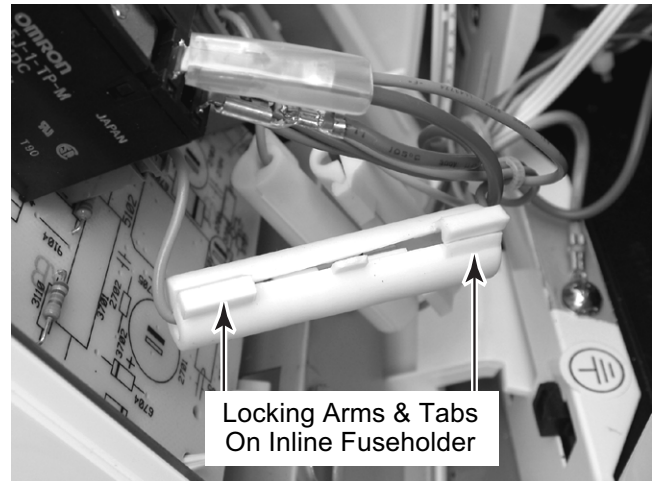

7. Open the fuseholder, slide the ends of the wire connectors off the ends of the fuse, and remove the fuse.

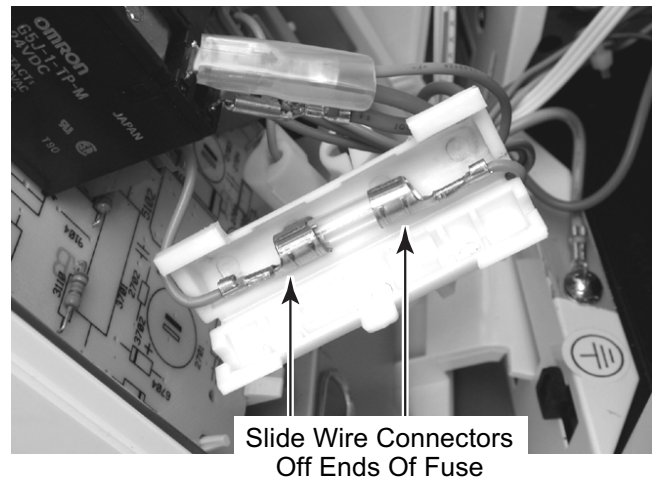

## REMOVING THE AC LINE FILTER CAPACITOR

### **⚠ WARNING**



**Electrical Shock Hazard**  
**Disconnect power before servicing.**  
**Replace all parts and panels before operating.**  
**Failure to do so can result in death or electrical shock.**

1. Unplug microwave oven or disconnect power.
2. Remove the air grille from the unit (see page 4-11 for the procedure).
3. Remove the control panel assembly (see page 4-12 for the procedure).
4. **Discharge the 1100 W inverter** (perform steps 3 and 4 on page 4-20).
5. Remove the AC line filter capacitor from the cooling fan motor and cut the wires from the capacitor leads.

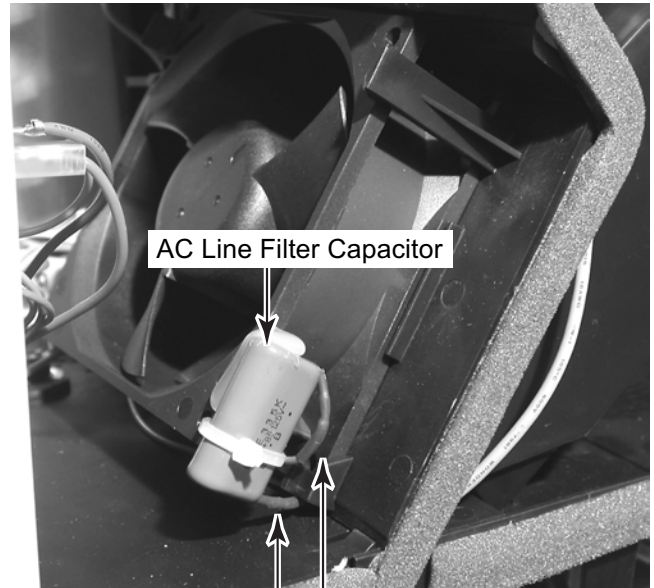

Cut Both Wires

6. Splice the wires coming from the new capacitor to the cut harness wires, and twist a pair of wire nuts over the ends of the cut wires.
7. Use a large bead of Selastic and adhere the capacitor to the fan.

# REMOVING THE COOLING FAN MOTOR, THE EXHAUST FAN THERMOSTAT, AND THE LINE FUSEHOLDER

## ⚠ WARNING



**Electrical Shock Hazard**  
**Disconnect power before servicing.**  
**Replace all parts and panels before operating.**  
**Failure to do so can result in death or electrical shock.**

1. Unplug microwave oven or disconnect power.
2. Remove the air grille from the unit (see page 4-11 for the procedure).
3. Remove the control panel assembly (see page 4-12 for the procedure).

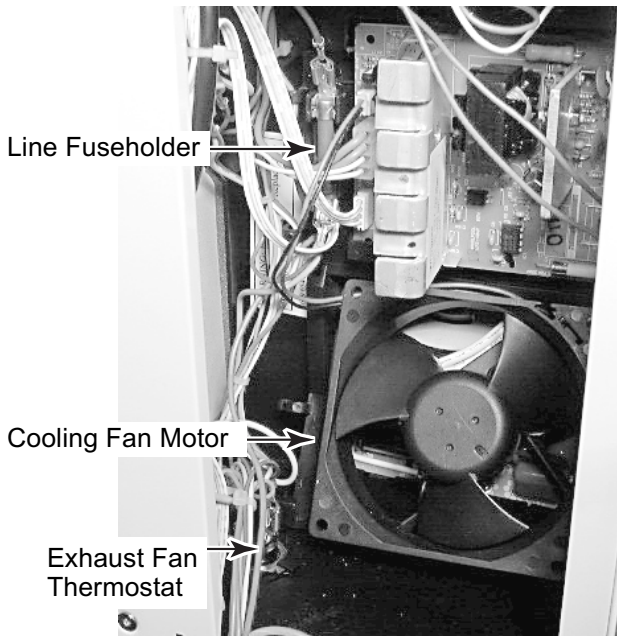

Located Behind Control Panel

4. To remove the cooling fan motor:
  - a) Press out on the top side locking tabs, lift the fan, and pull it forward to remove it.
  - b) Disconnect the 2-wire fan motor connector from connector CN153 on the 40 W inverter board.

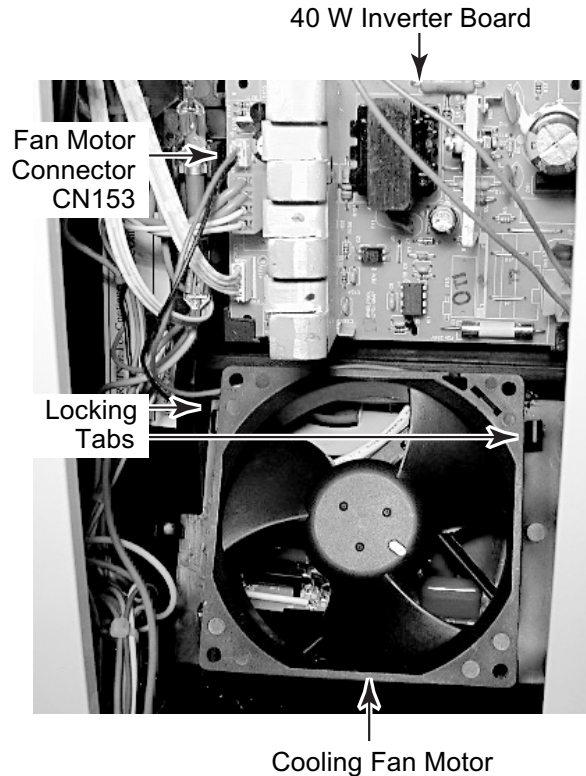

**REASSEMBLY NOTE:** When you reinstall the cooling fan motor, be sure to seat the bottom corners in the panel slots.

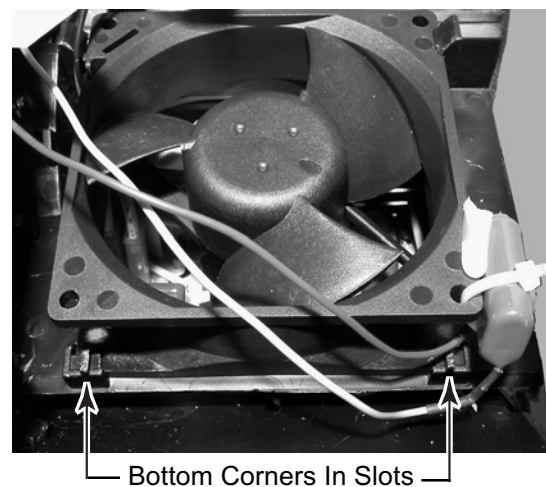

5. **To remove the exhaust fan thermostat:**

- a) Remove the cooling fan motor to make accessing the thermostat easier (see step 4 for the procedure).
- b) Disconnect the wire connectors from the thermostat terminals.
- c) Press down on the locking tab with a screwdriver blade, turn the thermostat so the flange is over the top of the tab, and lift the thermostat body out of the mounting hole.

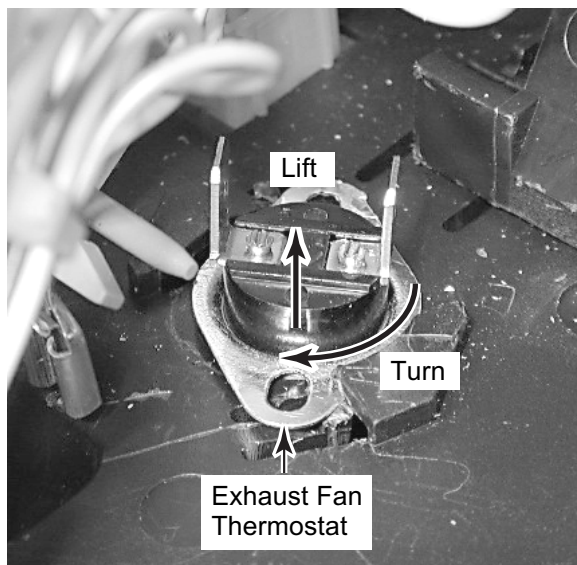
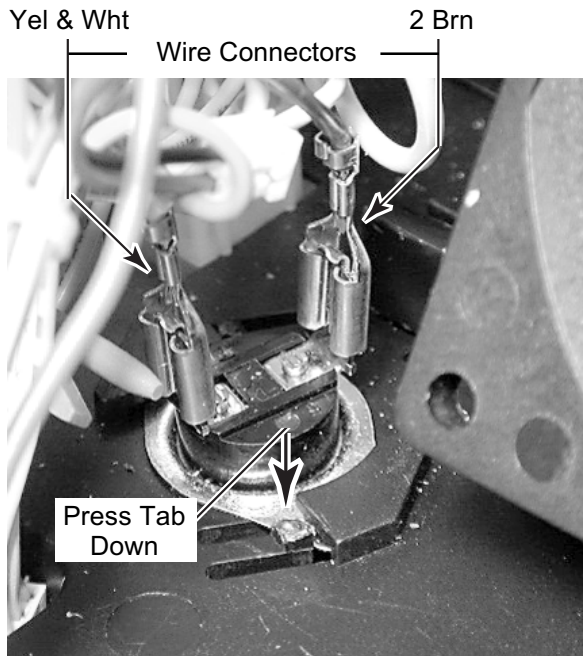

6. **To remove the line fuseholder:**

- a) Disconnect the wire connectors from the fuseholder terminals.
- b) Remove the fuse from the fuseholder.

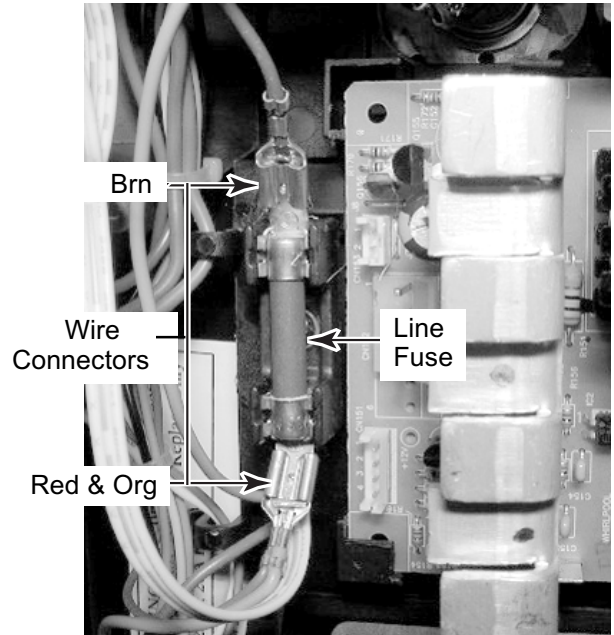

- c) Remove the screw from the fuseholder.

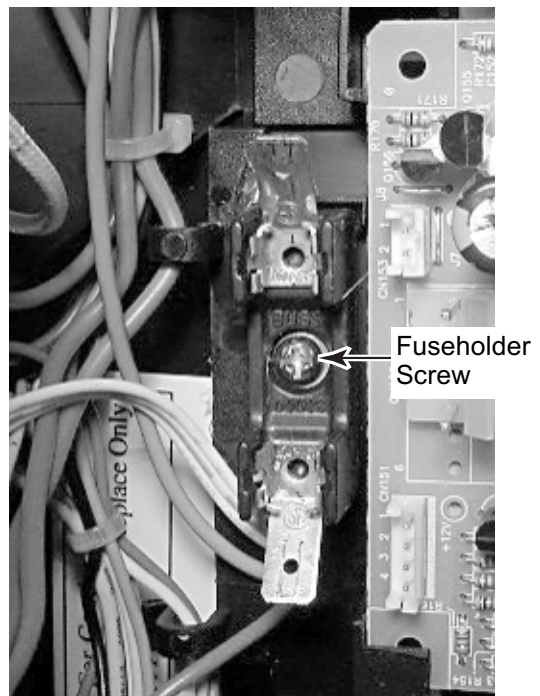

# REMOVING THE MOTOR CAPACITOR, THE MAGNETRON THERMOSTAT, & THE 40 W INVERTER BOARD

## ⚠ WARNING



**Electrical Shock Hazard**  
**Disconnect power before servicing.**  
**Replace all parts and panels before operating.**  
**Failure to do so can result in death or electrical shock.**

1. Unplug microwave oven or disconnect power.
2. Remove the air grille from the unit (see page 4-11 for the procedure).
3. Remove the control panel assembly (see page 4-12 for the procedure).

Magnetron Thermostat      Motor Capacitor

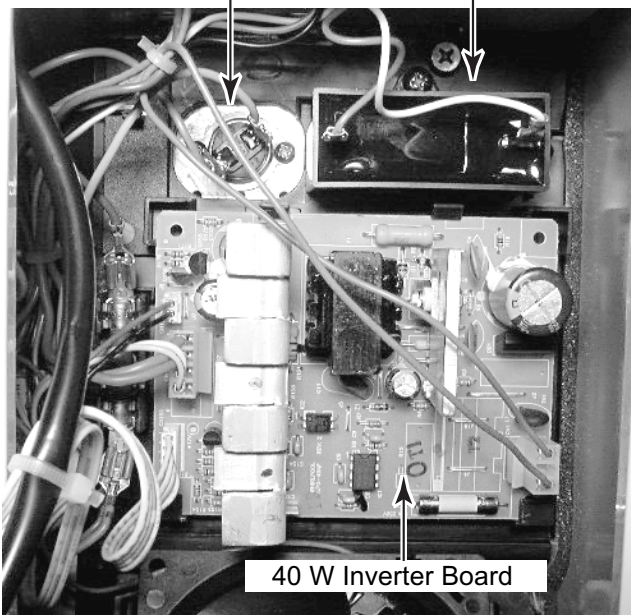

Located Behind Control Panel

4. To remove the motor capacitor, remove the phillips screw and disconnect the wire connectors from the terminals.

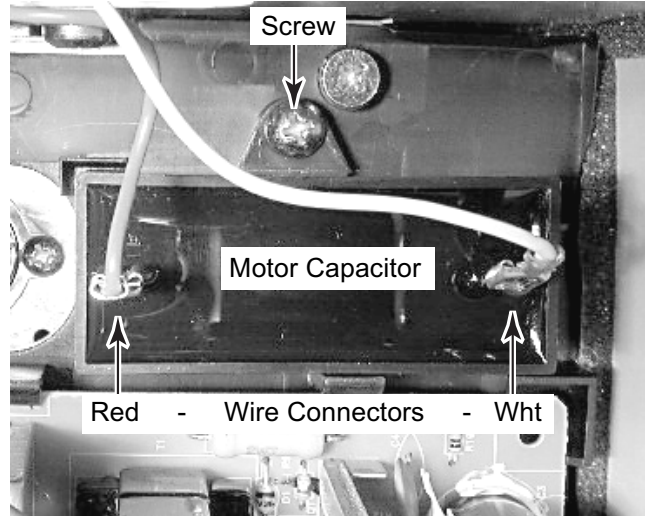

5. To remove the magnetron thermostat, remove the two phillips screws and disconnect the wire connectors from the terminals.

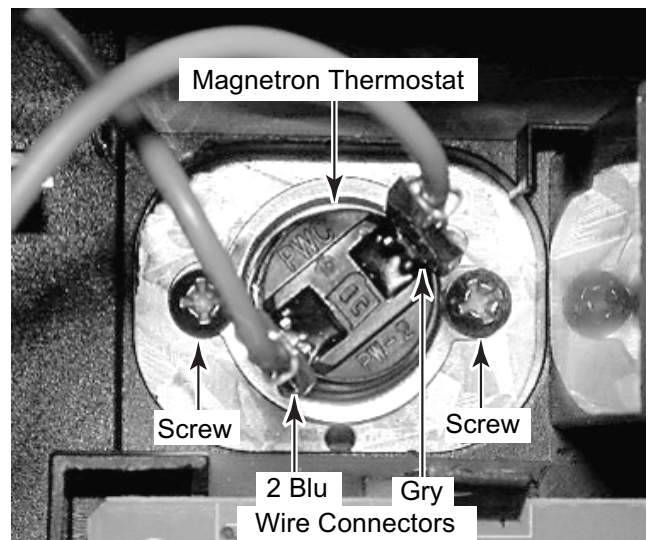

6. **To remove the 40 W inverter board:**  
a) Disconnect the wire connectors from:

CN1  
CN151  
CN152  
CN153

- b) Raise the two top locking arms and remove the inverter board.

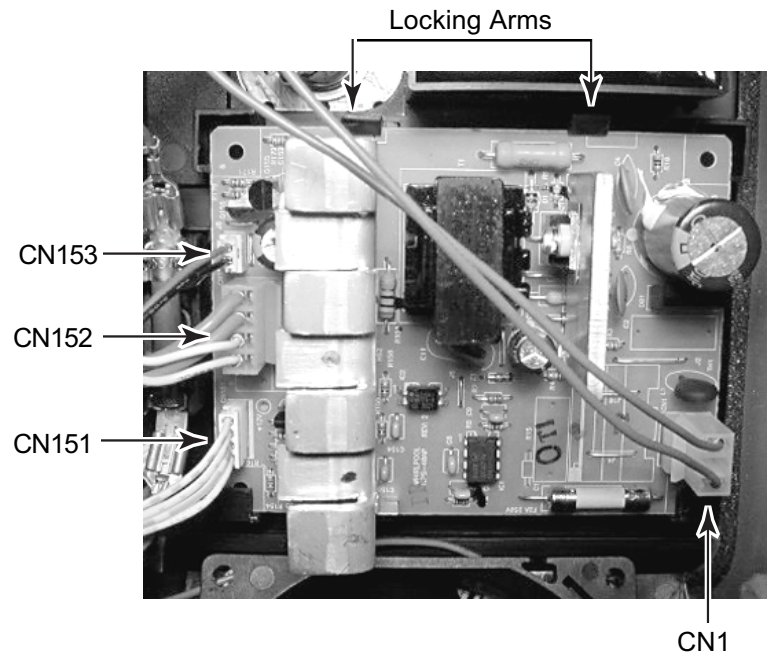

## REMOVING THE 1100 W INVERTER BOARD

### ⚠ WARNING



#### Electrical Shock Hazard

Disconnect power before servicing.

Replace all parts and panels before operating.

Failure to do so can result in death or electrical shock.

1. Unplug microwave oven or disconnect power.
2. Remove the control panel assembly (see page 4-12 for the procedure).
3. Remove the cooling fan motor (see page 4-16 for the procedure).

**NOTE:** Make sure to read the “Warnings” on page 1-4 before you continue.

4. Hold a 20,000 $\Omega$  (red-black-orange) 2-Watt resistor by the body with a pair of long nosed pliers, and touch the leads to the two discharge points on the 1100 W inverter. **Be careful not to touch the bare resistor leads during this procedure.**

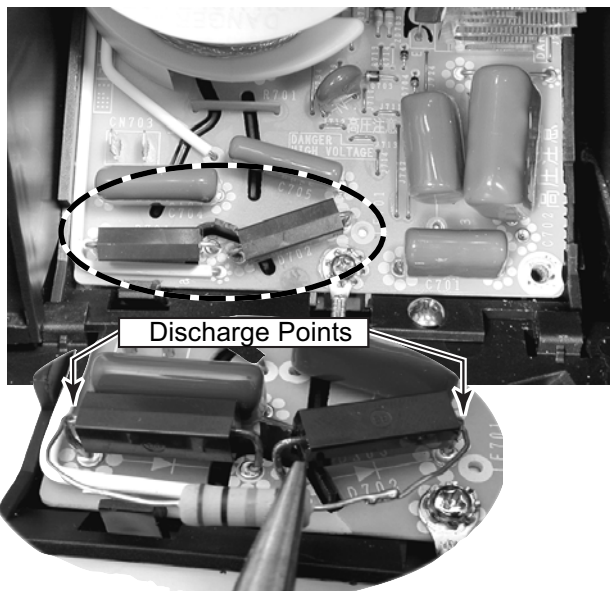

5. Remove the 40 W Inverter Board (see page 4-19 for the procedure).
6. Remove the exhaust fan thermostat (see page 4-17 for the procedure).
7. Disconnect the red and white wires from the motor capacitor, the blue and gray wires from the magnetron thermostat, and the brown, red, and orange wires from the line fuseholder terminals.
8. Remove the two screws from the front mounting panel.

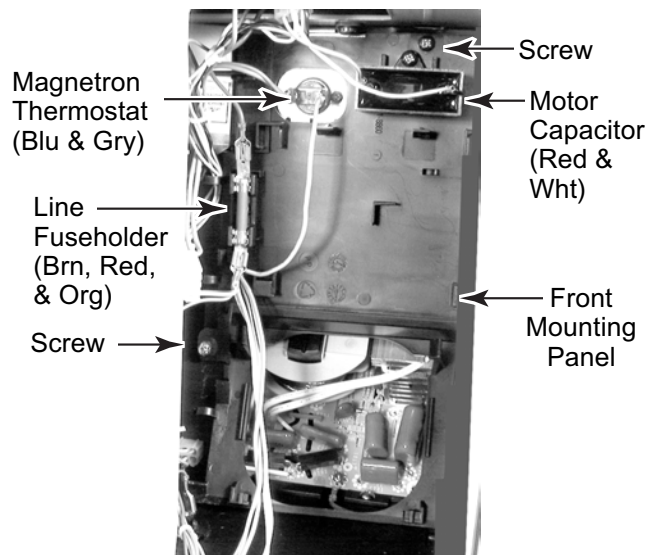

9. Pull the front mounting panel out the front of the unit, then remove the wires from the side of the panel.

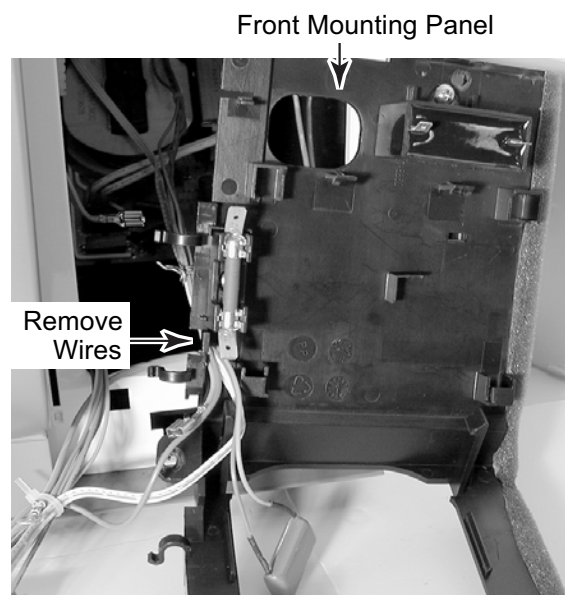



10. Disconnect the two magnetron wires from the 1100 W inverter (CN703) and remove them from the cover.
11. Lift the cover off the 1100 W inverter and remove it from the unit.

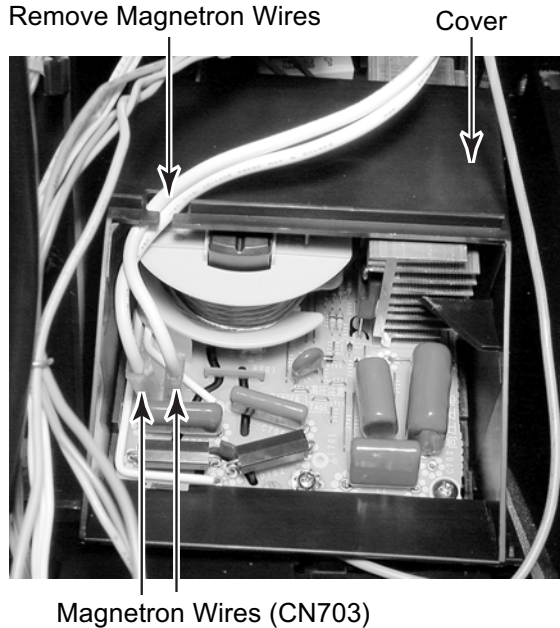

12. Remove the top and bottom mounting screws from the 1100 W inverter holder. Slide the holder to the right so the slot is over the tab at the bottom, and remove the holder and inverter.

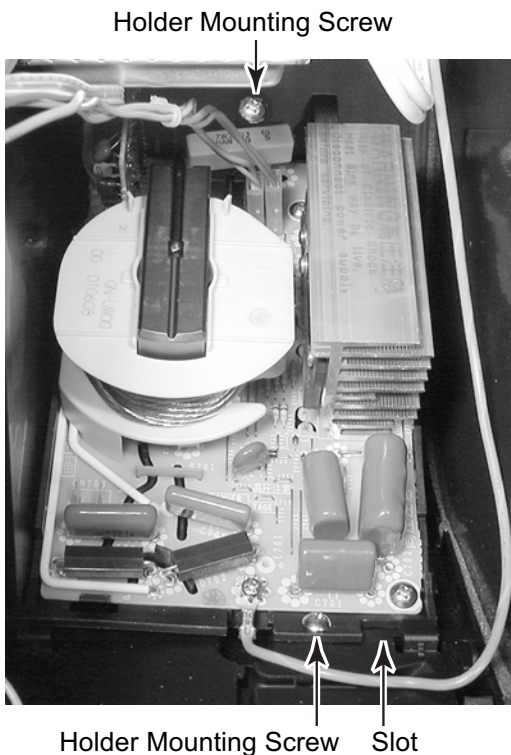

13. Remove the 2 red and 2 gray wires from the inverter terminals at CN702.
14. **Release the locking arm on the 3-wire cable at CN701** and disconnect it.
15. Remove the mounting screw from the board and unsnap the 1100 W inverter from the holder.

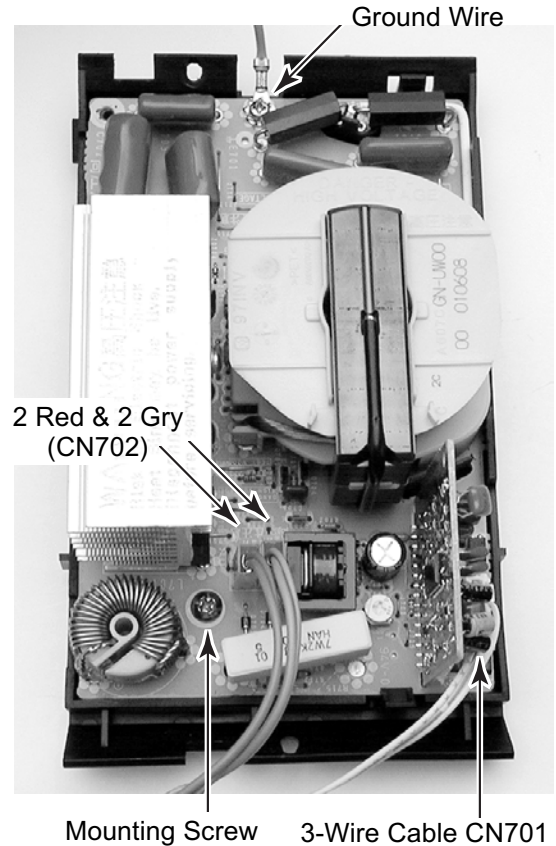

16. Remove the screw and nut from the green ground wire and remove the wire from the 1100 W inverter.

⚠ WARNING

Electrical Shock Hazard

Connect green ground wire to ground screw.

Failure to do so can result in death or electrical shock.

## REMOVING THE MAGNETRON

### ⚠ WARNING



#### Electrical Shock Hazard

**Disconnect power before servicing.**

**Replace all parts and panels before operating.**

**Failure to do so can result in death or electrical shock.**

1. Unplug microwave oven or disconnect power.
2. Remove the air grille from the unit (see page 4-11 for the procedure).
3. Remove the cabinet (see page 4-2 for the procedure).
4. Remove the control panel assembly (see page 4-12 for the procedure).

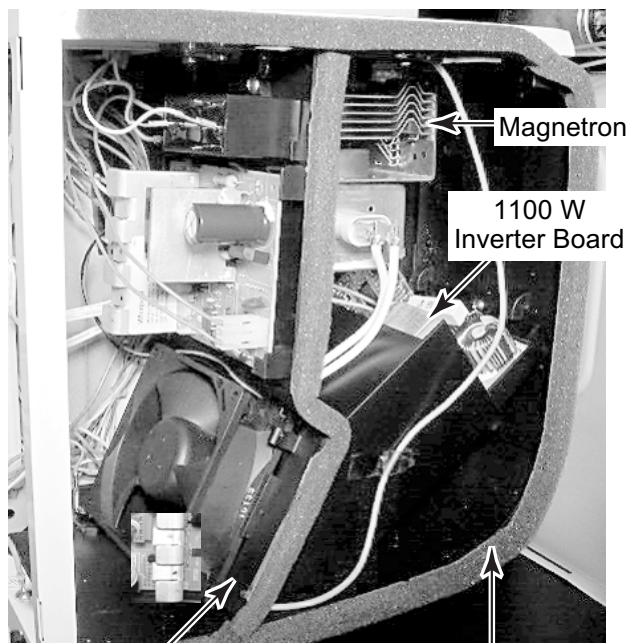

Front Mounting Panel

Rear Mounting Panel

5. Discharge the 1100 Watt inverter as follows. **NOTE:** Make sure that the screwdriver touches ground before touching the magnetron terminals.
  - a) Use a plastic handle screwdriver and touch the metal tip to the case of the magnetron.
  - b) Touch the screwdriver shaft against either of the two magnetron terminals for approximately 5 seconds.

Touch The Screwdriver Tip  
To The Magnetron Case



Touch The Screwdriver Shaft  
To Either Magnetron Terminal

6. Remove the screw from the front mounting panel.

Front Mounting Panel Screw

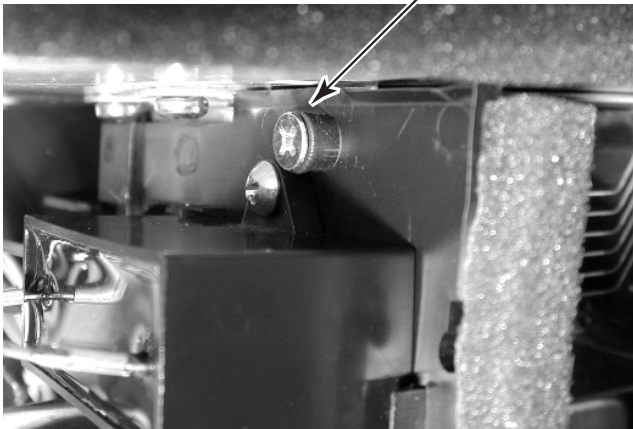

7. Bend the metal tab back, then slide the two rear mounting panel tabs toward the right side, and lower them through the cutouts in the chassis.

Rear Mounting Panel Tabs

Bend Metal Tab Back

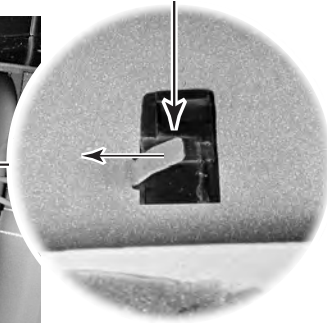
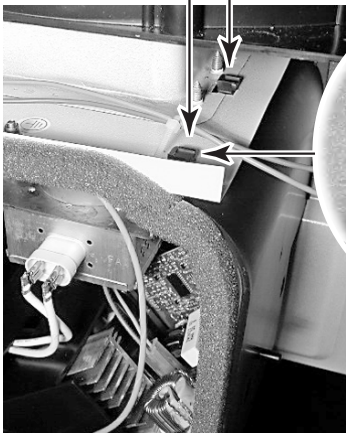

Lower The Rear Panel

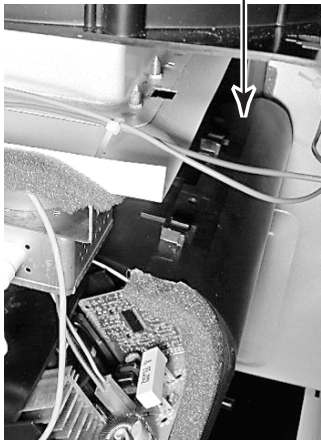

8. Disconnect the two filament wires from the magnetron terminals.
9. Remove the four mounting screws from the magnetron. **NOTE:** Pull the front mounting panel forward so you can access the two front screws.

**REASSEMBLY NOTE:** When you reinstall the magnetron, insert the alignment pins into their holes at the back of the magnetron.

Magnetron Screw (1 of 4)

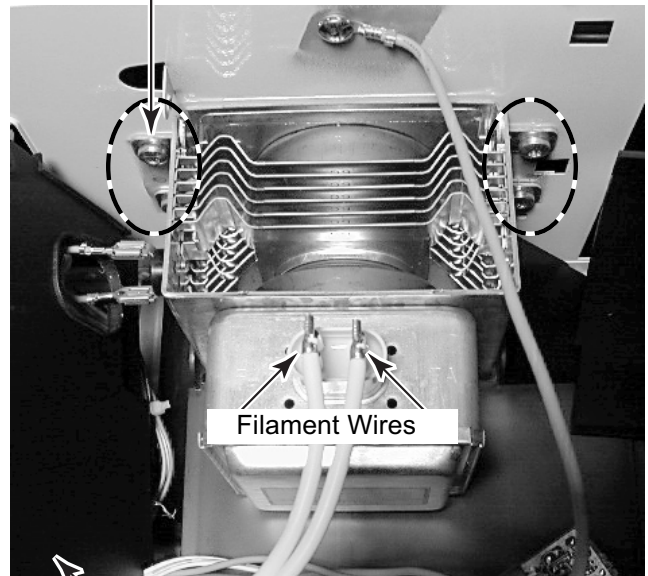

Filament Wires

Front Panel

# REMOVING THE PRIMARY & SECONDARY INTERLOCK SWITCHES AND THE MONITOR SWITCH

## ⚠ WARNING



### Electrical Shock Hazard

**Disconnect power before servicing.  
Replace all parts and panels before operating.  
Failure to do so can result in death or electrical shock.**

1. Unplug microwave oven or disconnect power.
2. Remove the air grille (see page 4-11 for the procedure).
3. Open the microwave oven door.
4. Remove the control panel assembly (see page 4-12 for the procedure).

### 5. To remove the secondary interlock switch or the monitor switch:

- a) Unsnap the linking rod and remove it.
- b) Carefully bend the two locking arms back and pull the switch off the two pins.
- c) Remove the wire connectors from the switch terminals.

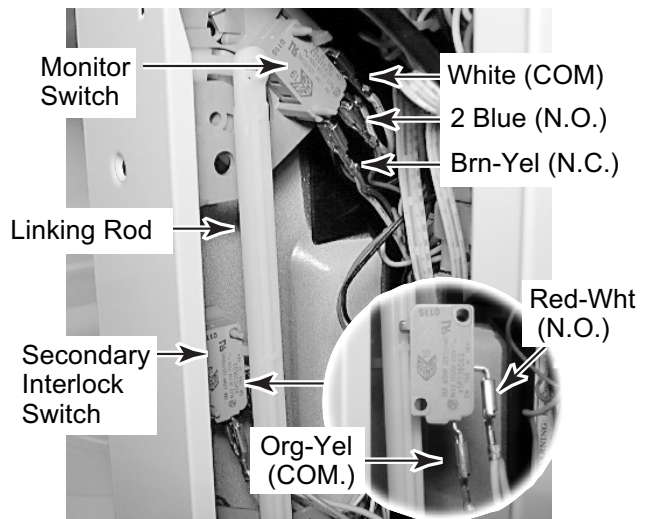

### 6. To remove the primary interlock switch:

- a) Grip the top and bottom of the linking rod with your fingers and carefully pull back on the switches so that they spring to their fully retracted position.

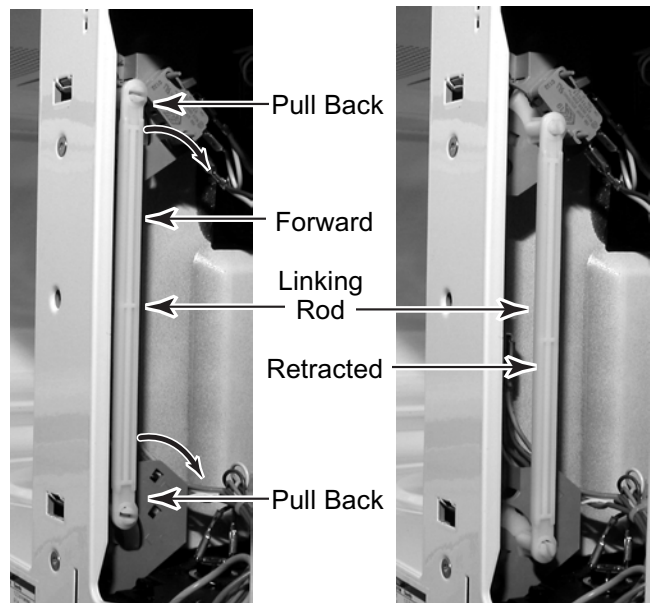

- b) Use a T10 torx screwdriver and remove the two screws from the interlock switch assembly.
- c) Pull the switch assembly away from the front chassis and position it so that you can access the primary interlock switch.

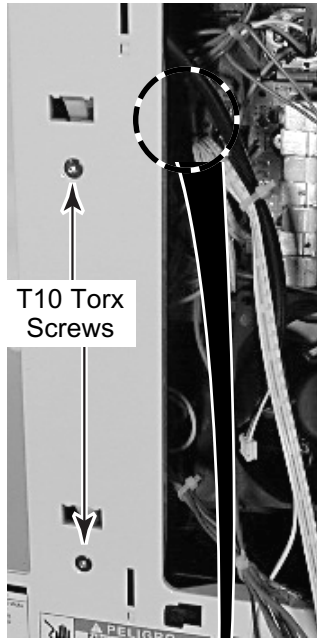

Primary Interlock Switch

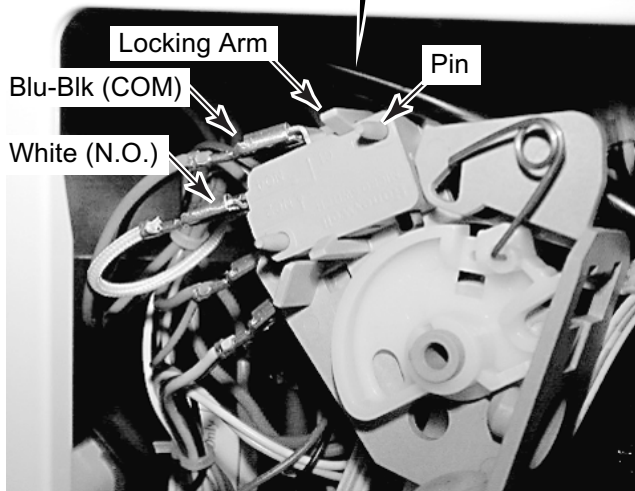

- d) Carefully unhook the two locking arms and pull the switch off the two pins.
- e) Remove the wire connectors from the switch terminals.

## REASSEMBLY NOTES:

1. When reinstalling the switch assembly after performing step 6, be sure to hook the plastic tabs, at the top and bottom of the switch holder, into the slotted metal retainers in the chassis, as shown below. Make sure that the metal retainers are not bent up so that the tabs will not fit into them. Otherwise, the switches may not operate properly.

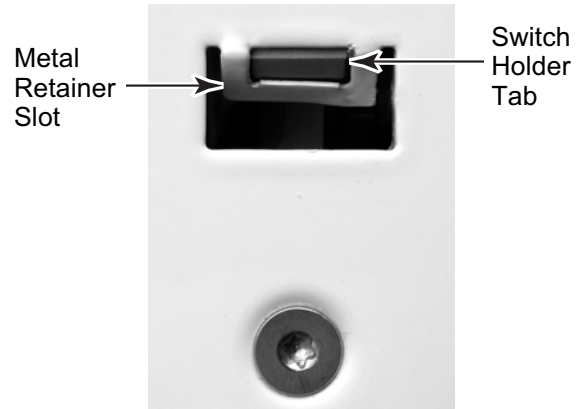

2. After installing the switch assembly, rotate the linking rod and two switches to their **forward** position (see the photos in step 6a). Close and open the door several times to make sure that the switches operate normally. If not, check step 1 above for proper installation, as well as the forward position of the switches.

# REMOVING THE TURNTABLE MOTOR

## ⚠ WARNING



### Electrical Shock Hazard

Disconnect power before servicing.

Replace all parts and panels before operating.

Failure to do so can result in death or electrical shock.

1. Unplug microwave oven or disconnect power.

2. Remove the cabinet (see page 4-2 for the procedure).
3. Open the microwave oven door and remove the spindle from the turntable motor shaft.

Turntable Spindle

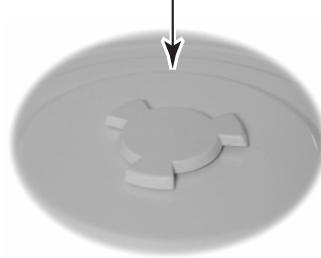

(Inside Oven Cavity)

4. Remove the bottom cover from the microwave oven (see page 4-3 for the procedure).
5. Remove the screws from the turntable motor and remove it.

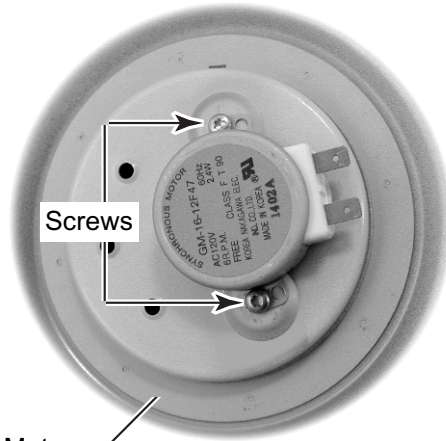

Turntable Motor

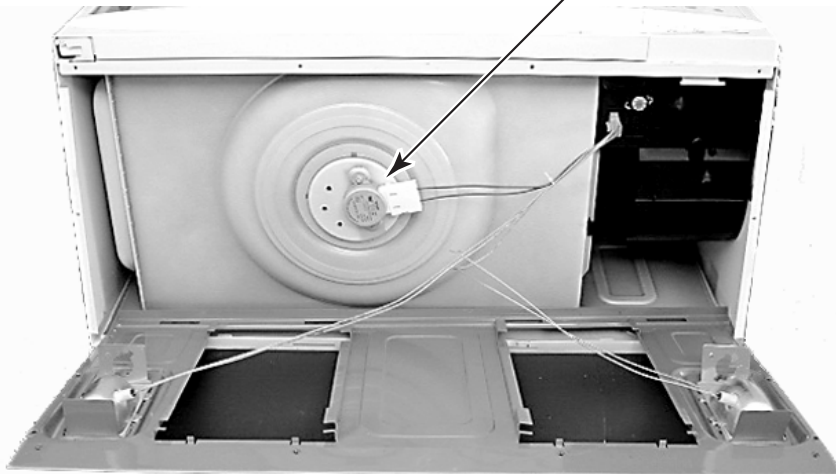

# REMOVING THE OVEN DOOR AND THE INNER PANEL

## ⚠ WARNING



**Electrical Shock Hazard**  
**Disconnect power before servicing.**  
**Replace all parts and panels before operating.**  
**Failure to do so can result in death or electrical shock.**

1. Unplug microwave oven or disconnect power.
2. Open the microwave oven door.
3. Pry the choke cover away from the top door pin, and remove the top pin from the pivot bracket. Lift the door off the bottom bracket, and remove it.

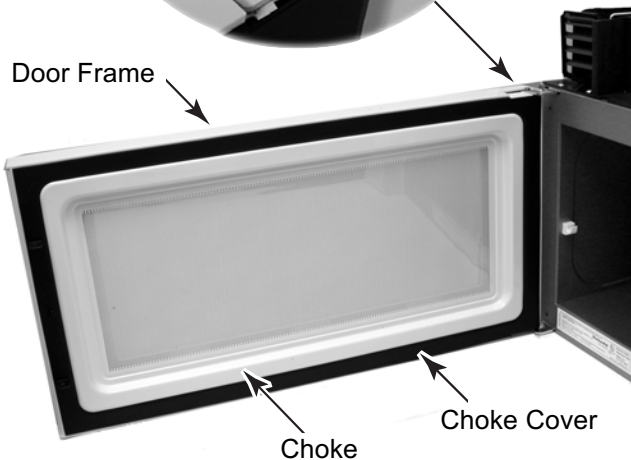
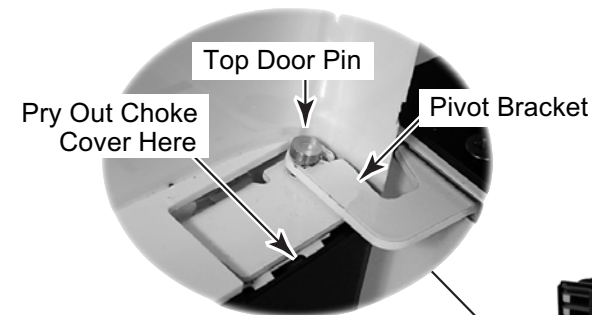

4. Place the oven door front side down on a padded surface.
5. Remove the choke screws from the door frame.

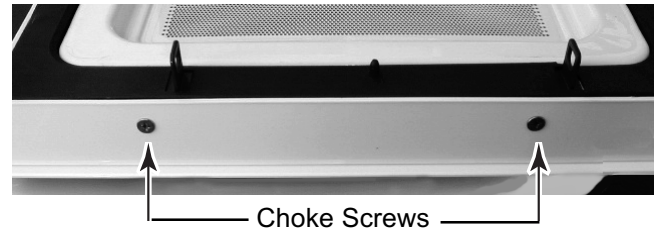

6. Starting at the top right corner, (see the round inset photo in the left column), pry the choke cover out with a putty knife, and unsnap it from the choke. Only remove the top, bottom and right sides of the choke cover at this time. You will remove the handle end of the choke cover later.

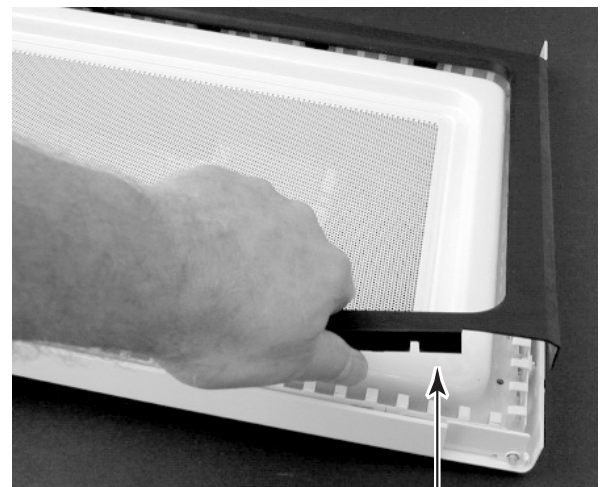

**Continued on the next page.**

- Starting at the top edge of the door near the center and working clockwise, use a putty knife, and pry the latching tabs of the choke out of the door frame slots. Lift the choke as you release the tabs so they do not snap back into the slots. **NOTE:** When you reach the handle side of door, pull both the choke and the choke cover away from the door frame, and then separate the two components.

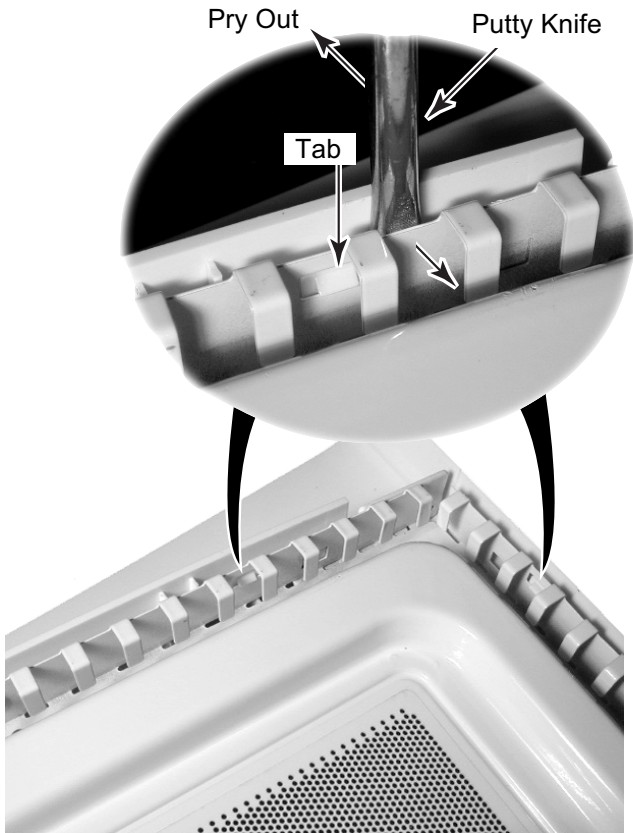

#### DOOR COMPONENTS

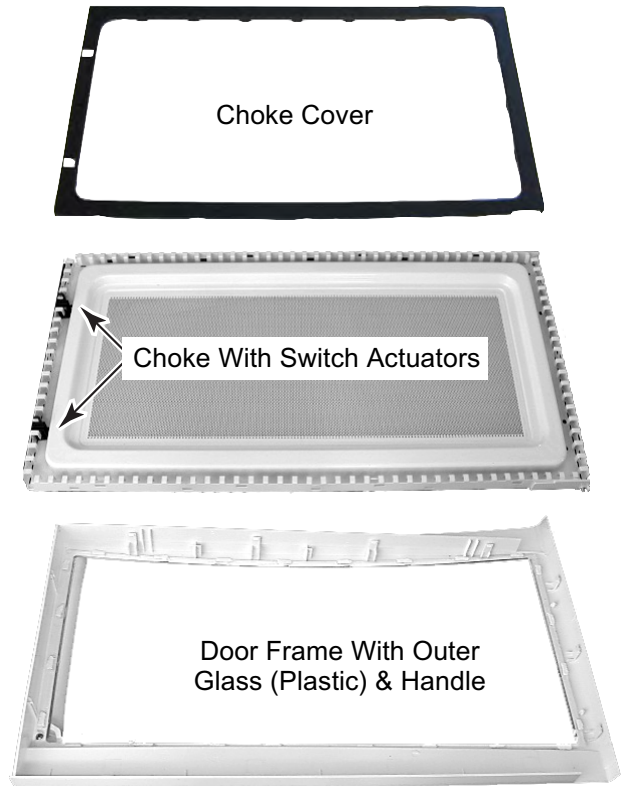

**REASSEMBLY NOTE:** When you reinstall the door on the oven, insert the top pin into the pivot bracket and press down on the pin until it snaps into place.

- To remove the door switch actuators from the choke, remove the screw from each actuator.

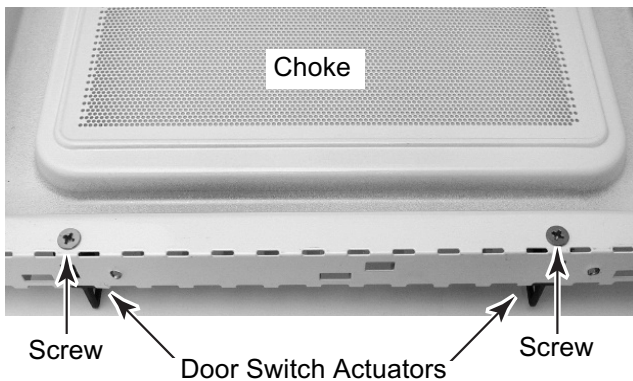



# COMPONENT TESTING

Discharge the 1100 W inverter before conducting any of the following tests (perform steps 1 through 4 on page 4-20).

All operational checks using microwave energy must be done with the microwave oven loaded with a minimum of 275 ml (9.3 oz.) of water in a microwave safe container.

Conduct a microwave energy test after performing any tests or repairs to the microwave.

Check that all wire leads are in the correct position before operating the microwave oven.

Grasp wire connectors when removing the wire leads from microwave parts.

	<b>⚠ WARNING</b>
	<b>Electrical Shock Hazard</b> <b>Disconnect power before servicing.</b> <b>Replace all parts and panels before operating.</b> <b>Failure to do so can result in death or electrical shock.</b>

## DOOR SWITCHES

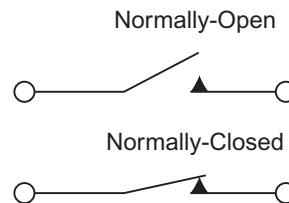
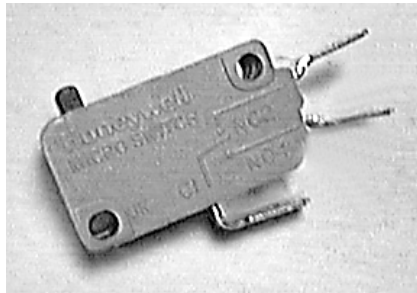

Refer to page 4-24 for the procedure for servicing the door switches.

1. Unplug microwave oven or disconnect power.
2. Disconnect the wires from the switch terminals.
3. Set the ohmmeter to the R x 1 scale.
4. Touch the ohmmeter test leads to the terminals of the **primary** or **secondary** interlock switch (normally-open). The meter should indicate an open circuit (infinite).

5. Touch the ohmmeter test leads to the terminals of the **monitor** switch (normally-closed). The meter should indicate a closed circuit (0  $\Omega$ ).

**NOTE:** Pressing the actuator button should result in opposite readings (normally-open should read closed, and normally-closed should read open).



# ⚠ WARNING

## Electrical Shock Hazard

**Disconnect power before servicing.**

**Replace all parts and panels before operating.**

**Failure to do so can result in death or electrical shock.**

### TOUCH PANEL CONTINUITY

To test the touch panel, perform the following steps:

1. Unplug microwave oven or disconnect power.
2. Disconnect the ribbon cable from the control board connector P7.

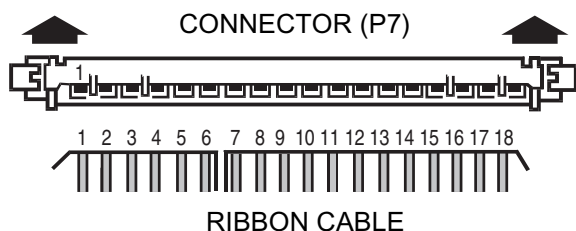

3. Set the ohmmeter to the R x 1 scale.
4. Use a pair of alligator clips and clip them to the ribbon contact numbers shown along the top and side of the indicated keyboard matrix, shown below.

For example:

- a) Install alligator clips over contacts 5 and 17 of the ribbon cable.
- b) Touch the alligator clips with the test leads.
- c) Press the BEVERAGE keypad. The meter should indicate a resistance of approximately 200 Ω.

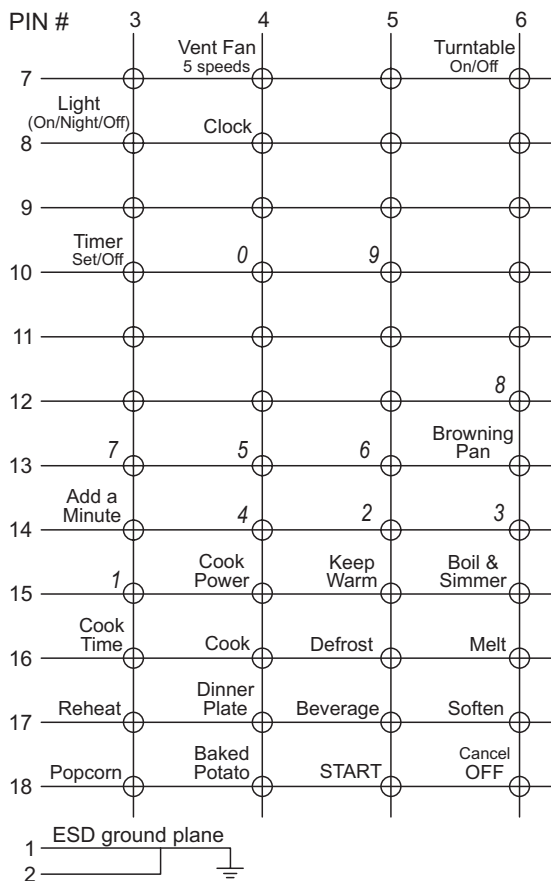



## ⚠ WARNING

### Electrical Shock Hazard

Disconnect power before servicing.

Replace all parts and panels before operating.

Failure to do so can result in death or electrical shock.

### STIRRER & TURNTABLE MOTORS

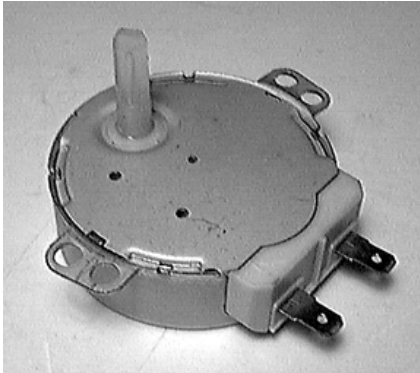

Refer to pages 4-6 and 4-26 for the procedures for servicing the stirrer and turntable motors.

1. Unplug microwave oven or disconnect power.
2. Disconnect the wire connectors from the motor under test.
3. Set the ohmmeter to the R x 1K scale.
4. Touch the ohmmeter test leads to the stirrer motor terminals. The meter should indicate between 3300 and 4200  $\Omega$ .
5. Touch the ohmmeter test leads to the turntable motor terminals. The meter should indicate between 2700 and 3800  $\Omega$ .

### AC LINE FILTER CAPACITOR



Refer to page 4-15 for the procedure for servicing the AC line filter capacitor.

1. Unplug microwave oven or disconnect power.
2. **Discharge the 1100 W inverter** (perform steps 2 through 4 on page 4-20).
3. Set the ohmmeter to the R x 1000 scale.
4. Touch the ohmmeter test leads to the bare wires near the capacitor body (you may have to pull the insulation back slightly). The meter should briefly indicate approximately 10K ohms, and then gradually return towards infinity.



## ⚠ WARNING

### Electrical Shock Hazard

Disconnect power before servicing.

Replace all parts and panels before operating.

Failure to do so can result in death or electrical shock.

### HUMIDITY SENSOR

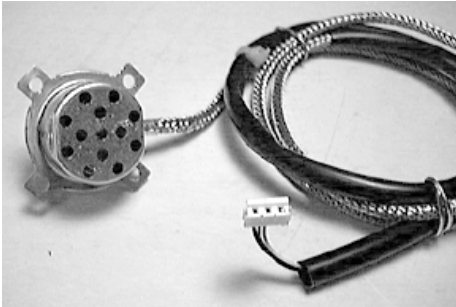

Refer to page 4-4 for the procedure for servicing the humidity sensor.

1. Unplug microwave oven or disconnect power.
2. Disconnect the 3-wire connector from the control board.
3. Set the ohmmeter to the R x 1K scale.
4. Touch the ohmmeter test leads to the indicated wire terminals of the 3-wire connector. The meter should indicate as follows:

Black to white = approximately 2800  $\Omega$   
@ 77°F/25°C.

White to red = approximately 2800  $\Omega$   
@ 77°F/25°C.

### CAVITY THERMOSTATS 1, 2, & 3

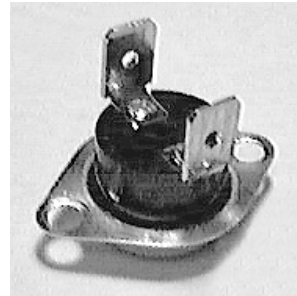

Refer to pages 4-4 and 4-8 for the procedures for servicing the cavity thermostats.

1. Unplug microwave oven or disconnect power.
2. Disconnect the wires from the terminals.
3. Set the ohmmeter to the R x 1 scale.
4. Touch the ohmmeter test leads to the terminals. The meter should indicate a closed circuit (0  $\Omega$ ).

**NOTE:** Thermostat 1 opens @ 329°F / 165°C.  
Thermostats 2 and 3 open @ 257°F / 125°C. If the thermostat is defective, the ohmmeter will indicate an infinite circuit.



## ⚠ WARNING

### Electrical Shock Hazard

Disconnect power before servicing.

Replace all parts and panels before operating.

Failure to do so can result in death or electrical shock.

### LINE FUSE & EXHAUST FAN THERMOSTAT

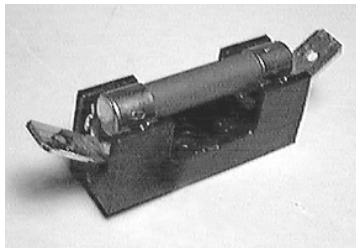

Line Fuse

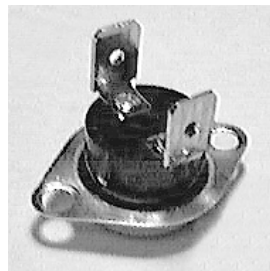

Exhaust Fan Thermostat

Refer to page 4-16 for the procedures for servicing the line fuse and the exhaust fan thermostat.

1. Unplug microwave oven or disconnect power.
2. Set the ohmmeter to the R x 1 scale.
3. **To test the line fuse**, touch the ohmmeter test leads to the ends of the fuse. The meter should indicate a closed circuit (0  $\Omega$ ).
4. **To test the exhaust fan thermostat:**
  - a) Disconnect the wires from the terminals.
  - b) Touch the ohmmeter test leads to the terminals. The meter should indicate an open circuit (infinite). **NOTE:** The thermostat closes @ 140°F / 60°C, and will reset (open) @ 104°F / 40°C.

### MOTOR CAPACITOR



Refer to page 4-18 for the procedure for servicing the motor capacitor.

1. Unplug microwave oven or disconnect power.
2. **Discharge the 1100 W inverter** (perform steps 2 through 4 on page 4-20).
3. Disconnect the wires from the terminals.
4. Set the ohmmeter to the R x 10K scale.
5. Touch the ohmmeter test leads to the capacitor terminals. The meter should indicate several thousand ohms and gradually return to infinity.



## ⚠ WARNING

### Electrical Shock Hazard

**Disconnect power before servicing.**

**Replace all parts and panels before operating.**

**Failure to do so can result in death or electrical shock.**

### COOLING FAN MOTOR (12 VDC)

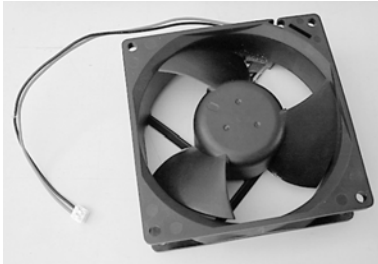

Refer to page 4-16 for the procedure for servicing the cooling fan motor.

1. Unplug microwave oven or disconnect power.
2. Disconnect the wire connectors from the cooling fan motor terminals.
3. Set the ohmmeter to the R x 1 scale.
4. Touch the ohmmeter test leads to the motor terminals. The meter should indicate between 17 and 28  $\Omega$ .
5. An additional test for the cooling fan motor is as follows (see the photo below):
  - a) Connect a battery connector to a fresh 9 volt battery.
  - b) Connect the red wire from the battery connector to the red wire in the fan connector, and the black wire to the black wire in the fan connector.

Cooling Fan Motor

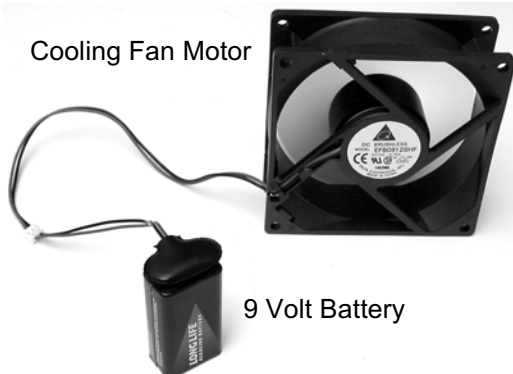

9 Volt Battery

### HOOD EXHAUST FAN MOTOR (120 VAC)



Refer to page 4-10 for the procedure for servicing the hood exhaust fan motor.

1. Unplug microwave oven or disconnect power.
2. Disconnect the hood exhaust fan motor connector from the main harness connector.
3. Set the ohmmeter to the R x 1 scale.
4. Touch the ohmmeter test leads to the motor terminals. The meter should indicate as follows:

White to black = 30 to 60  $\Omega$ .

Red to black = 40 to 80  $\Omega$ .



## ⚠ WARNING

### Electrical Shock Hazard

Disconnect power before servicing.

Replace all parts and panels before operating.

Failure to do so can result in death or electrical shock.

### MAGNETRON

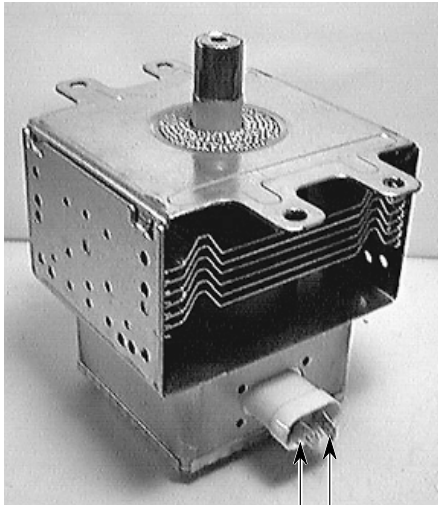

Filament Terminals

Refer to page 4-22 for the procedure for servicing the magnetron.

1. Unplug microwave oven or disconnect power.
2. **Discharge the 1100 W inverter** (perform step 5 on page 4-22).
3. Disconnect the wire connectors from the filament terminals.
4. Set the ohmmeter to the R x 1 scale.
5. Touch the ohmmeter test leads to the filament terminals. The meter should indicate less than 1  $\Omega$ .
6. Touch one ohmmeter test lead to the chassis and the other to each of the filament terminals. The meter should indicate an open circuit (infinite).

### MAGNETRON THERMOSTAT (N.C.)



Refer to page 4-18 for the procedure for servicing the magnetron thermostat.

1. Unplug microwave oven or disconnect power.
2. Disconnect the wires from the magnetron thermostat terminals.
3. Set the ohmmeter to the R x 1 scale.
4. Touch the ohmmeter test leads to the terminals. The meter will indicate a closed circuit (0  $\Omega$ ) at room temperature. **NOTE:** The thermostat opens @ 293°F / 145°C and resets (closes) @ 221°F / 105°C.

## ⚠ WARNING



### Electrical Shock Hazard

Power is present during the following tests.

## INVERTERS

### MEASURING OVEN INPUT CURRENT

1. Remove the screw from the power cord retaining plate and remove the plate.
2. Pull the power cord out of the cabinet and separate the wires.
3. Connect an ammeter clamp around the white power cord wire.

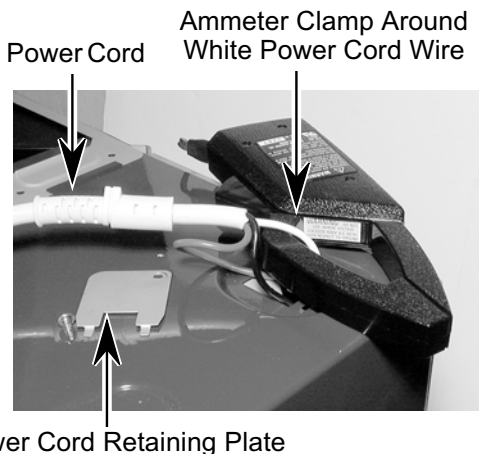

4. Turn the microwave oven On.
5. Check the ammeter for a 15A reading.
  - If the ammeter indicates more than 0.5 amps, check the magnetron and its wiring.
  - If the ammeter indicates less than 0.5 amps, it indicates that there is no input to the 1100 W inverter. Check for the following:
    - No AC voltage supply or control signal. Check the control power supply board at the relay terminals for 120 VAC (see the photos at the top of the next column).

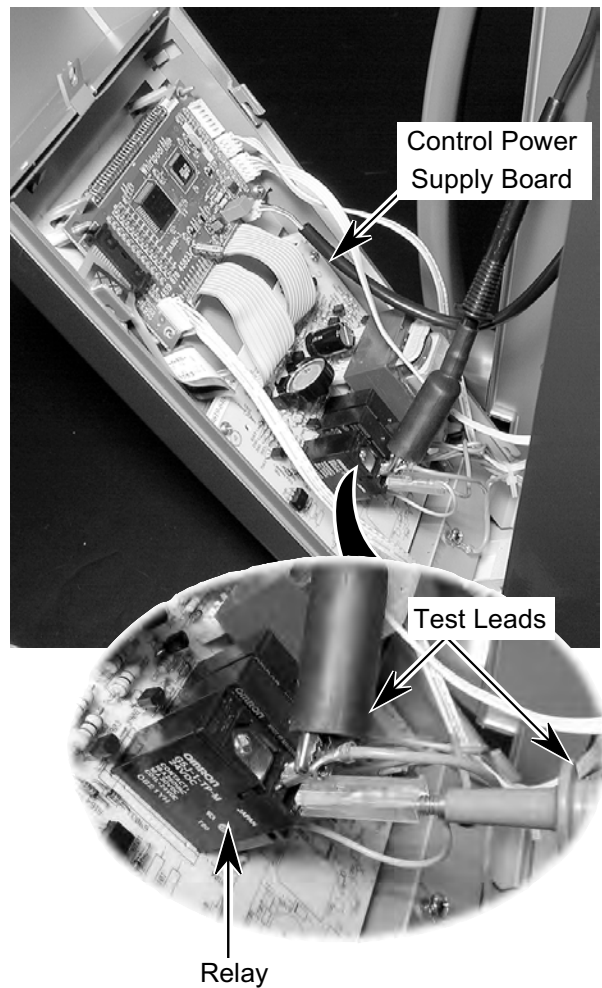

## ⚠ WARNING



### Electrical Shock Hazard

**Disconnect power before servicing.**

**Replace all parts and panels before operating.**

**Failure to do so can result in death or electrical shock.**

### 1100 W INVERTER

Refer to page 4-20 for the procedure for servicing the 1100 W inverter.

**IMPORTANT: HIGH VOLTAGE—DO NOT MEASURE!**



**NOTE:** Refer to the “Warnings” on page 1-4. Do not attempt to repair, or make any adjustments to the inverter board.

**Check Wiring**

1. Unplug microwave oven or disconnect power.
2. **Discharge the 1100 W inverter** (perform steps 2 through 4 on page 4-20).
3. Visually inspect inverter board connectors CN701, CN702, CN703, and E701. Check for signs of failure due to loose wiring, unseated connectors, and discoloration due to overheating.

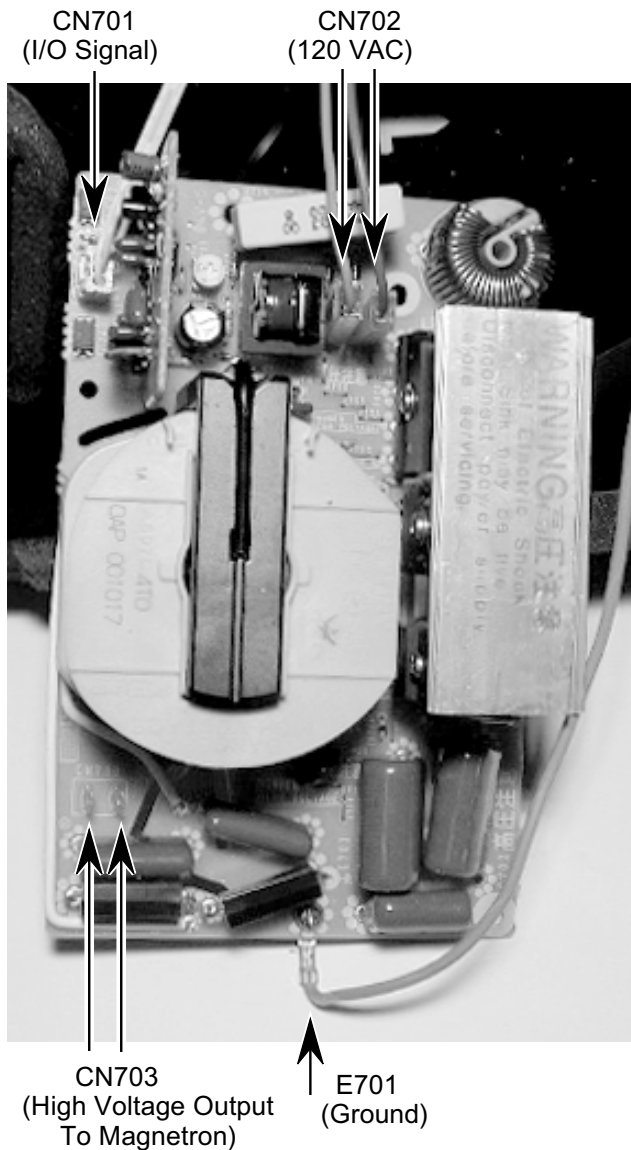

**⚠ WARNING**



**Electrical Shock Hazard**

**Disconnect power before servicing.**

**Replace all parts and panels before operating.**

**Failure to do so can result in death or electrical shock.**

**40 W INVERTER**

Refer to page 4-18 for the procedure for servicing the 40 W inverter.

**Check Wiring**

1. Unplug microwave oven or disconnect power.
2. Visually inspect inverter board connectors CN1, CN151, CN152, and CN153. Check for signs of failure due to loose wiring, unseated connectors, and discoloration due to overheating.

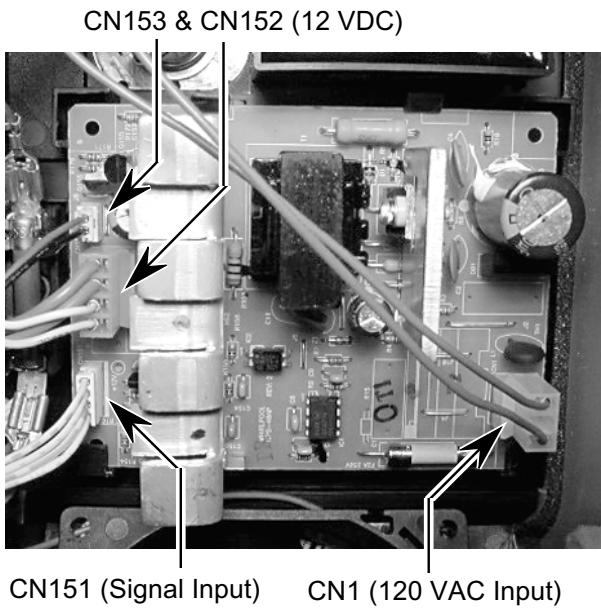

**Continued on the next page.**

# ⚠ WARNING



## Electrical Shock Hazard

Power is present during the following tests.

### Check DC Output Voltage

1. Unplug microwave oven or disconnect power.
2. Tilt the control panel back so you can access the 40 W inverter board.
3. Set the voltmeter to measure 12 volts DC.

**NOTE:** The 40 W inverter output voltages that will be tested in the following steps are shown in the chart below.

Connector	Test Points	Output Voltage
CN152	Pins 1 & 2	12 volts DC
	Pins 3 & 4	
CN153*	Pins 1 & 2	12 volts DC

\* Test in "Demo Mode."

4. Connect power to the microwave oven.
5. Open the oven door.
6. Touch the voltmeter test probes to pins **1** and **2** of connector **CN152** (refer to the photo on the previous page). The meter should indicate 12 volts DC.
7. Close the oven door.
8. Press the LIGHT keypad on the control panel and set the lights to full intensity. **NOTE:** Do not press the LIGHT keypad during the measurement.
9. Touch the voltmeter test probes to pins **3** and **4** of connector **CN152**. The meter should indicate 12 volts DC.
10. Press and release the CANCEL/OFF keypad.
11. Press and hold the TIMER keypad until a small "d" appears on the display, (after approximately 5 seconds), then release the keypad.
12. Turn the microwave oven on.
13. Touch the voltmeter test probes to pins **1** and **2** of connector **CN153**. The meter should indicate 12 volts DC.
14. Press and release the CANCEL/OFF keypad.
15. Press and hold the TIMER keypad until the small "d" disappears from the display and release the keypad.

# DIAGNOSIS & TROUBLESHOOTING

## POWER OUTPUT MEASUREMENT

The power output of the magnetron can be measured using the following test. Before you perform the test:

- Make sure that the microwave oven cavity is clean and cool.
  - Check the line voltage at the microwave oven and note the reading.
1. Fill a glass beaker with 32 oz. (1000 ml) of tap water.
  2. Stir the water with a thermometer and record the temperature. The temperature should be between 50° and 75°F (10° and 24°C).
  3. Place the beaker of water in the center of the microwave oven cavity.
  4. Operate the microwave oven on high power for 1 minute.
  5. Remove the beaker of water and stir it with the thermometer for about 20 seconds.
  6. Record the temperature of the water.
  7. Subtract the temperature of the water you recorded in step 2 from the water temperature in step 6. The normal rise in temperature range is shown in the following chart.

Voltage (VAC Under Load)	Temperature Rise	
	°C	°F
120	12 - 15	22 - 26
108	10 - 12	19 - 21

## FAILURE CODES

Display	Likely Failure Condition	Recommended Repair Procedure
Flashing colon “:”	Power Failure	After a power failure, the colon “:” will be flashing. Press any key to end this indication. The colon will then be steady when in standby.
<b>-F2-</b>	Keyboard Failure	<ol style="list-style-type: none"> <li>1. Unplug microwave oven or disconnect power.</li> <li>2. Replace membrane switch.</li> <li>3. Plug in microwave oven or reconnect power.</li> <li>4. If problem persists, go to step 5.</li> <li>5. Unplug microwave oven or disconnect power.</li> <li>6. Replace control system assembly.</li> </ol>
<b>-F3H-</b>	Humidity Sensor Failure	<ol style="list-style-type: none"> <li>1. Unplug microwave oven or disconnect power.</li> <li>2. Connect a new sensor to the board (at P5).</li> <li>3. Plug in microwave oven or reconnect power.</li> <li>4. If no failure code appears when starting sensor function: <ul style="list-style-type: none"> <li>– Unplug microwave oven or disconnect power.</li> <li>– Replace sensor.</li> </ul> </li> <li>5. Otherwise: <ul style="list-style-type: none"> <li>– Unplug microwave oven or disconnect power.</li> <li>– Replace control system assembly.</li> </ul> </li> </ol>
<b>-F3T</b>	Temperature Sensor Failure	<ol style="list-style-type: none"> <li>1. Check that the oven temperature is not below 41°F (5°C) or above 140°F (60°C).</li> <li>2. If problem persists: <ul style="list-style-type: none"> <li>– Unplug microwave oven or disconnect power.</li> <li>– Replace control system assembly.</li> </ul> </li> </ol>
<b>-F7-</b>	Power to Magnetron Interrupted	<ol style="list-style-type: none"> <li>1. Unplug the oven for at least 40 seconds. Check to see if this solves the problem. (Possible reason: Overtemperature protection for the magnetron operated earlier.)</li> <li>2. Unplug microwave oven or disconnect power.</li> <li>3. Check the resistance of the magnetron thermostat. It should be close to 0 ohms.</li> <li>4. Check the magnetron.</li> <li>5. Check wiring to the 1100 W inverter and control system.</li> <li>6. Check operation of all interlock switches.</li> <li>7. If switches operate correctly, <ul style="list-style-type: none"> <li>– Unplug microwave oven or disconnect power.</li> <li>– Replace 1100 W inverter.</li> </ul> </li> <li>8. If problem persists, replace control system assembly.</li> </ol>

**NOTE:** If lights work, but cooling fan does not, 40W inverter may have failed.

# DISPLAY AND POWER BOARD CALLOUTS

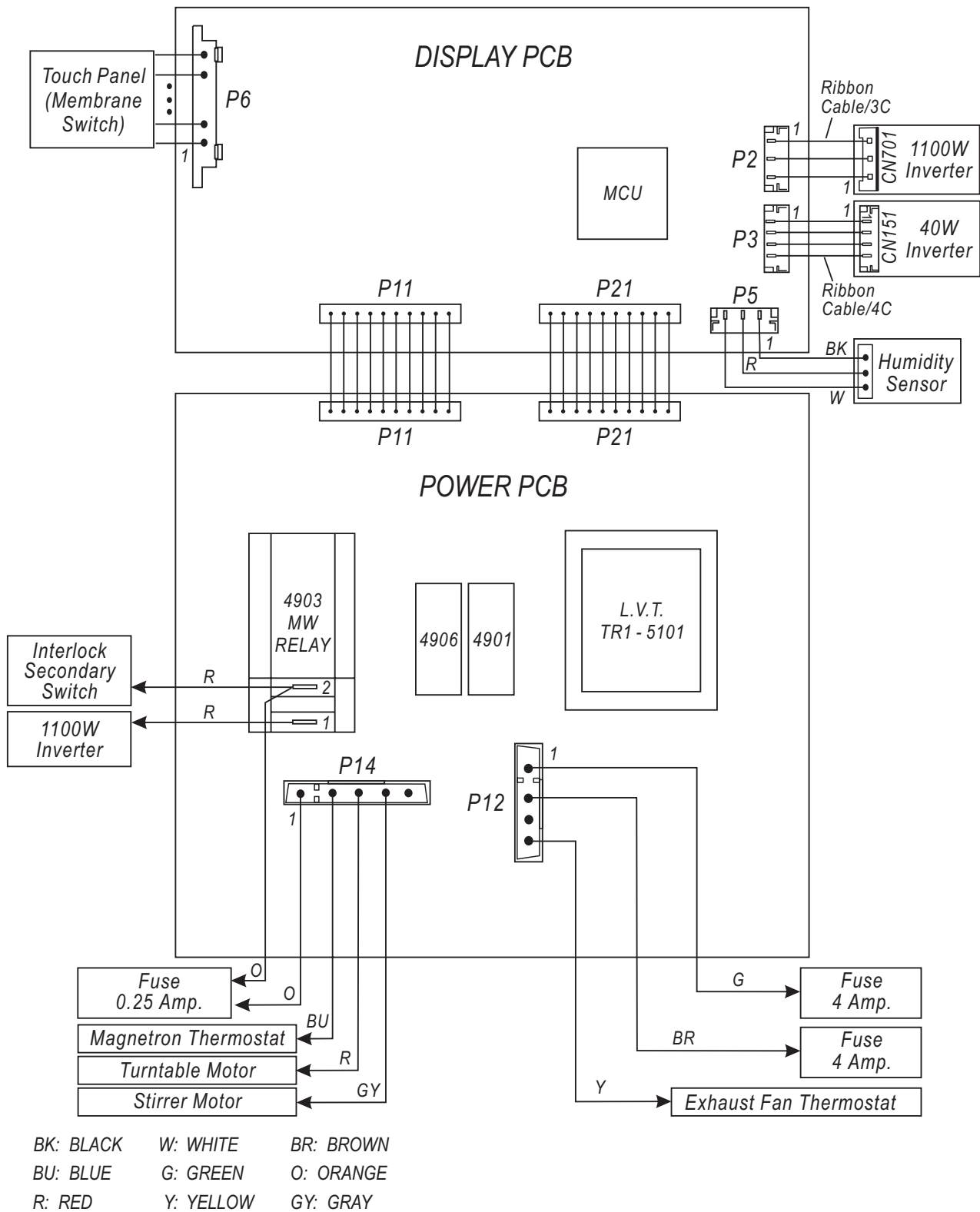

# PRIMARY, SECONDARY, & MONITOR SWITCH CHECKS

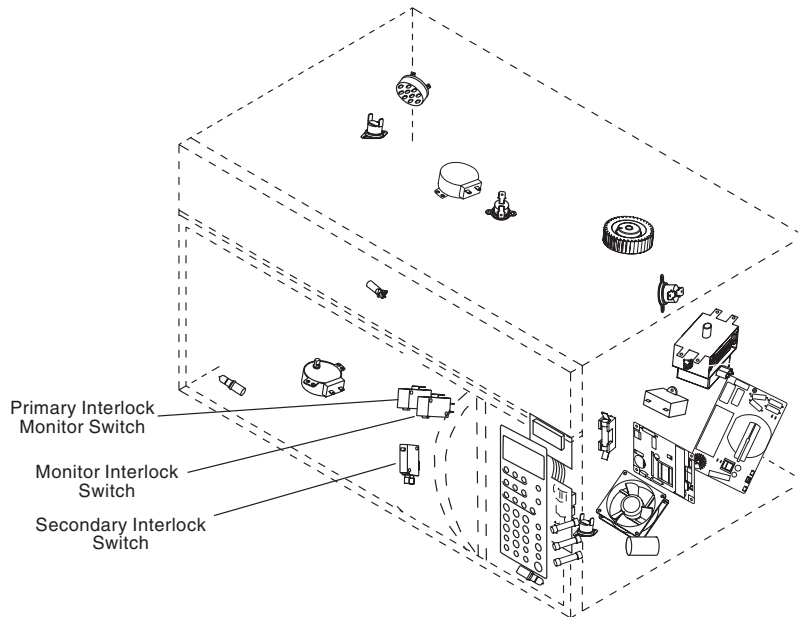

Switch	Check By	Door Open	Door Closed
Primary Interlock	<ol style="list-style-type: none"> <li>1. Unplug microwave oven or disconnect power.</li> <li>2. Disconnect the wires at the Primary Interlock Switch.</li> <li>3. Check from the common terminal (Blue/Black wires) to the normally open terminal (White wire).</li> </ol>	-	+
Secondary Interlock	<ol style="list-style-type: none"> <li>1. Unplug microwave oven or disconnect power.</li> <li>2. Disconnect the wires at the Secondary Interlock Switch.</li> <li>3. Check from the common terminal (Orange/Yellow wires) to the normally open terminal (White/Red wires).</li> </ol>	-	+
Monitor	<ol style="list-style-type: none"> <li>1. Unplug microwave oven or disconnect power.</li> <li>2. Disconnect the wires at the Monitor Switch.</li> <li>3. Check from the common terminal (White/Blue wires) to the normally closed terminal (Yellow/Brown wires).</li> </ol>	+	-

(+) Continuity (-) No Continuity

**NOTE:** These diagrams are not intended to show a complete circuit. They represent the position of the switches during “Door Open” and “Door Closed” (continuity checks only).

## DOOR CLOSED

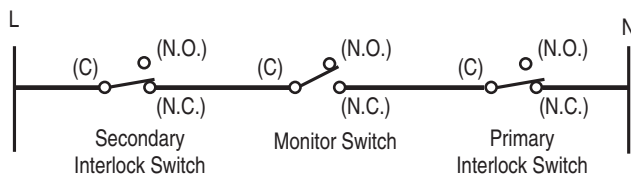

## DOOR OPEN

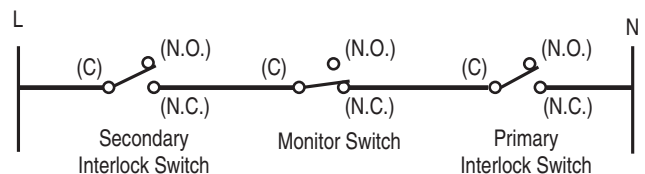

# TOUCH PANEL & MICROCOMPUTER BOARD TEST

The microwave oven has a self-diagnostic test that can be accessed through the touch panel keypad. To perform the test:

1. Be sure power is connected to the microwave oven and that the door is closed.

**NOTE:** You will have to access the touch panel and the power cord plug in the next step. If you cannot access them both, have another person available to help you with the step.

2. Perform the following sequence to enter the touch panel “self-test” mode:
  - a) Press and **hold** the CANCEL/OFF keypad.
  - b) Open the oven door.
  - c) Unplug the power cord plug for 2 seconds and then plug it back in.
  - d) Release the CANCEL/OFF keypad and close the door.
3. Press each touch panel keypad, as shown in the Key Table to the right. As you do, the number “8” should appear in the display position shown in the chart, to indicate that the circuits are complete, and that the relays are working properly.

**NOTE:** If you should press the CANCEL/OFF keypad during any of the tests, you will exit the test mode. Perform step 2 to reenter the test mode.



Key Name	Function	Display Position*
Popcorn	–	1
Baked Potato	–	2
Dinner Plate	–	3
Beverage	–	5
Reheat	–	1
Cook	Humidity Sensor	◆
Defrost	–	3
Keep Warm	–	5
Soften	–	1
Melt	–	2
Broil & Simmer	–	3
Browning Pan	–	4
1	Relay 4901	1
2	Hood Light	2
3	Relay 4903	3
Cook Time	–	5
4	–	1
5	–	2
6	Relay 4906	3
Cook Power	–	5
7	–	1
8	–	2
9	Hood Fan Triac	3
Add a Minute	–	5
Timer Set/Off	–	1
0	–	2
Clock	Buzzer	3
Light On/Night/Off	–	1
Vent Fan 5 Speeds	–	2
Turntable On/Off	–	3
Start	–	5
Cancel OFF	Exit Test Mode	–

\* “8” will appear in the display position indicated in the table. Display position 1 is farthest to the left. Display position 5 is farthest to the right.

- ◆ Eight seconds after pressing COOK, “Hmxxx” will appear in the display (xxx = humidity reading).

# WIRING DIAGRAMS & STRIP CIRCUITS

## SCHEMATIC DIAGRAM

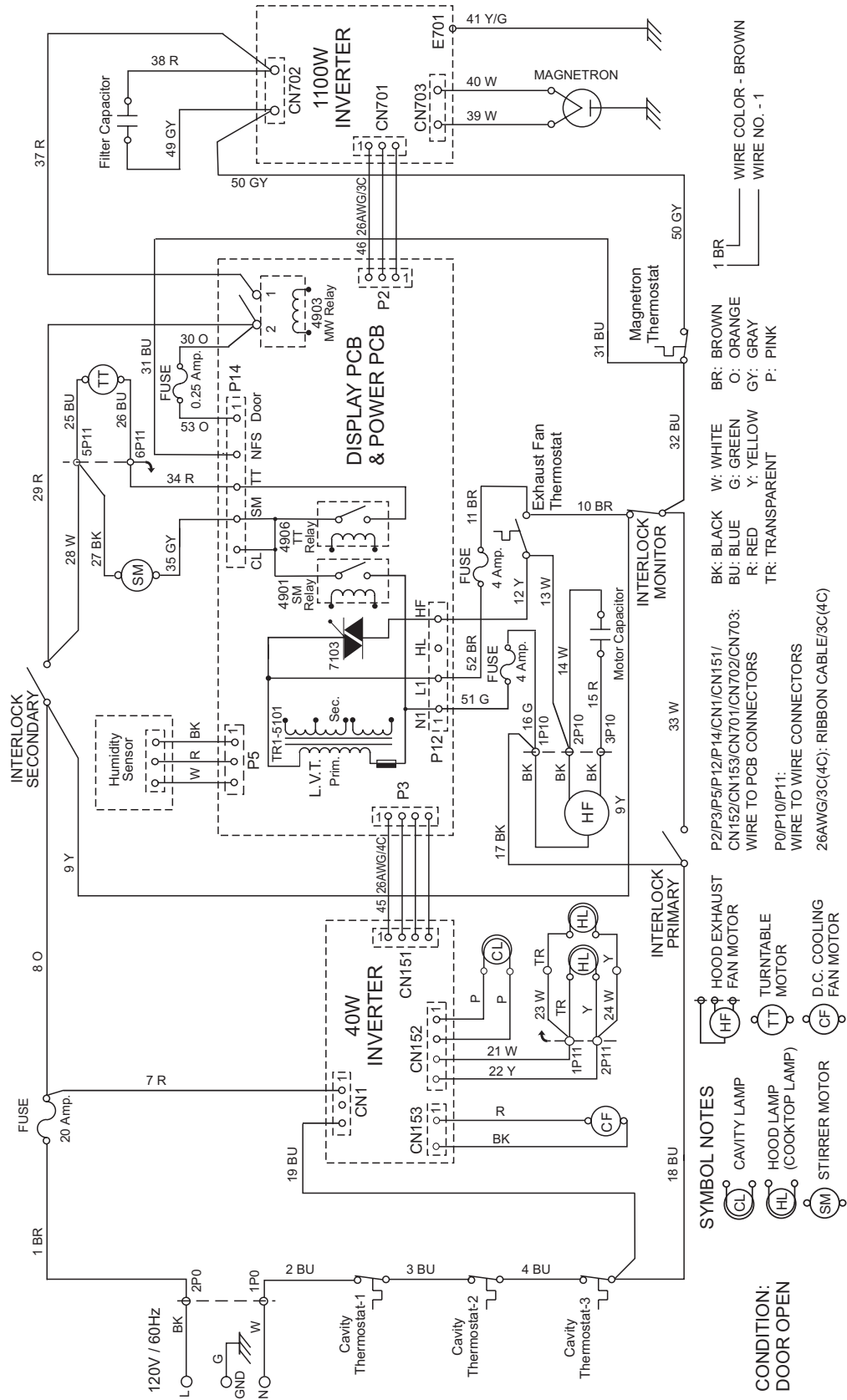

# WIRING DIAGRAM

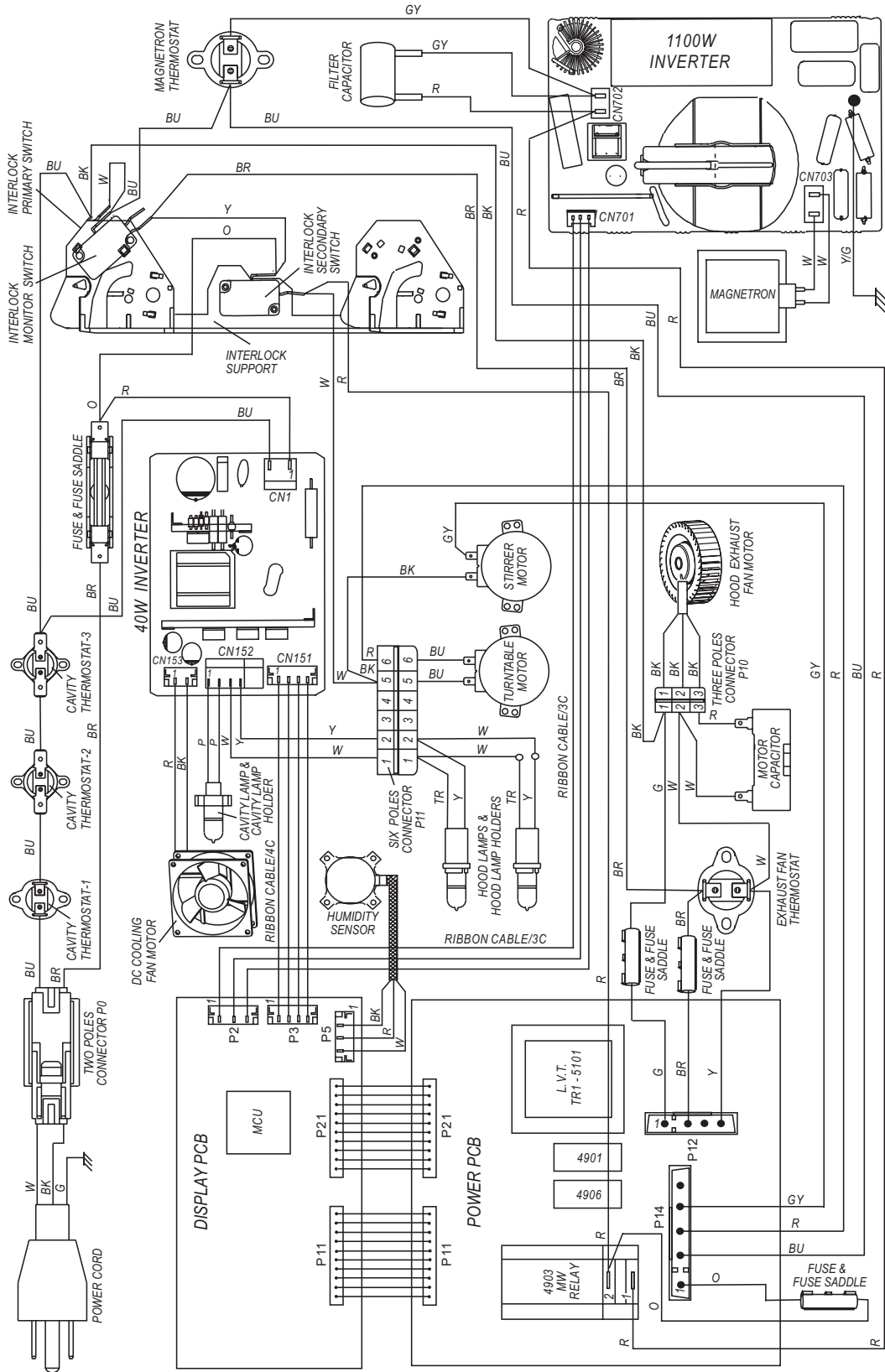

BK: BLACK    W: WHITE    BR: BROWN  
 BU: BLUE    G: GREEN    O: ORANGE  
 R: RED    Y: YELLOW    GY: GRAY  
 TR: TRANSPARENT



# STRIP CIRCUITS

## MICROWAVE COOKING

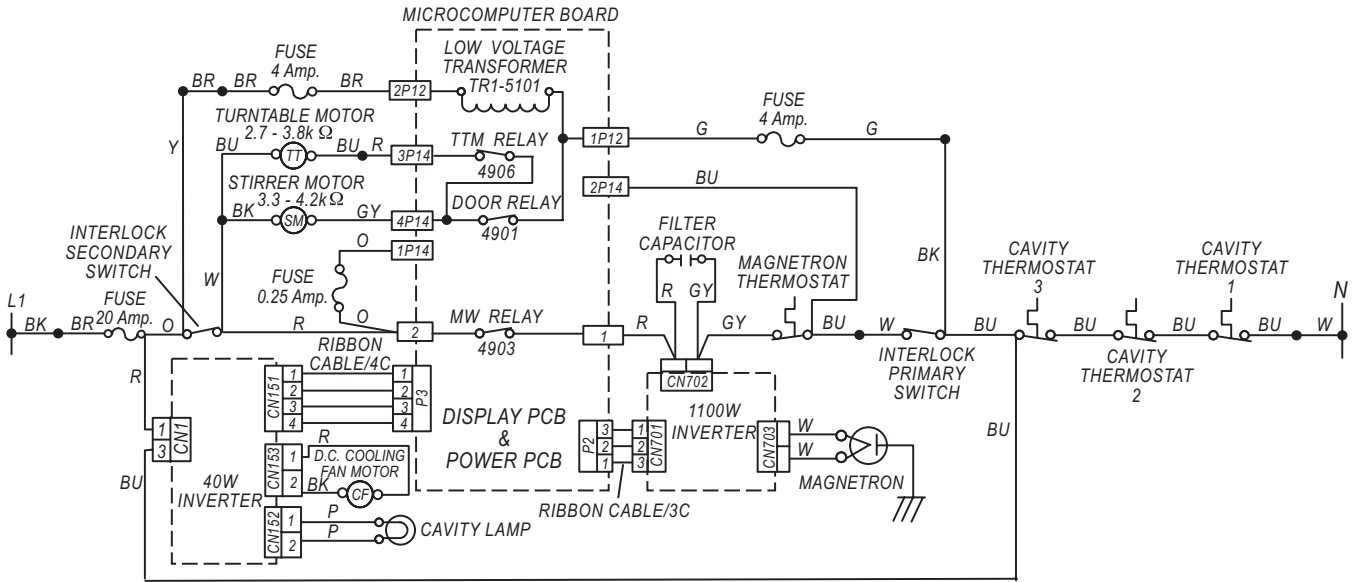

## BLOWER FAN ON AUTOMATIC

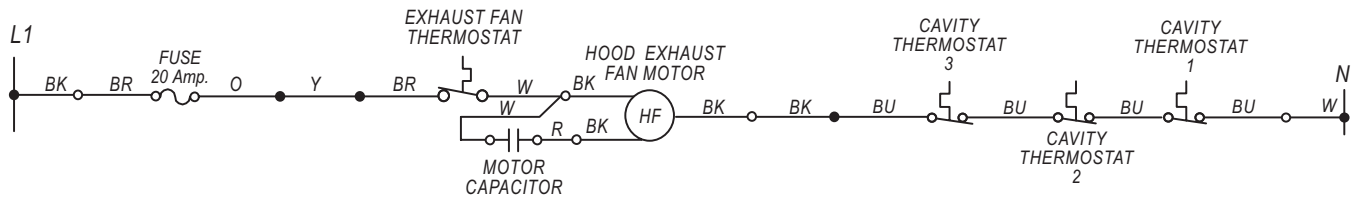

## BLOWER FAN ON VARIABLE

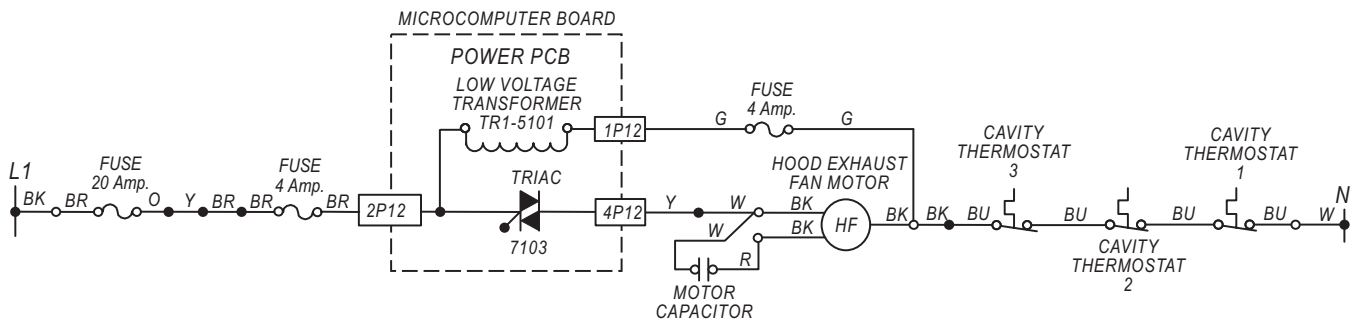

## MICROWAVE TIME-OF-DAY DISPLAYED

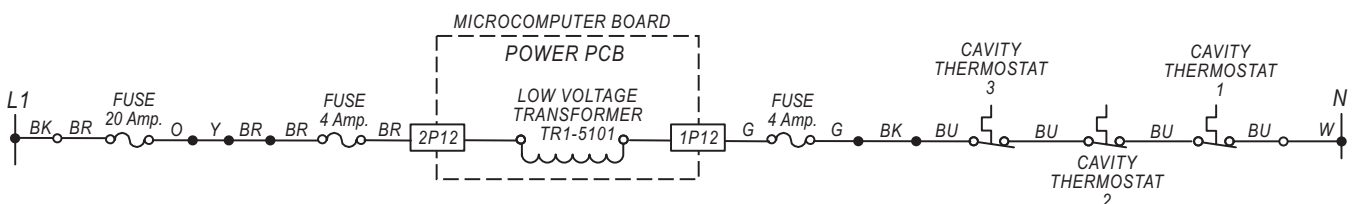

## DOOR OPEN - CAVITY LAMP ON

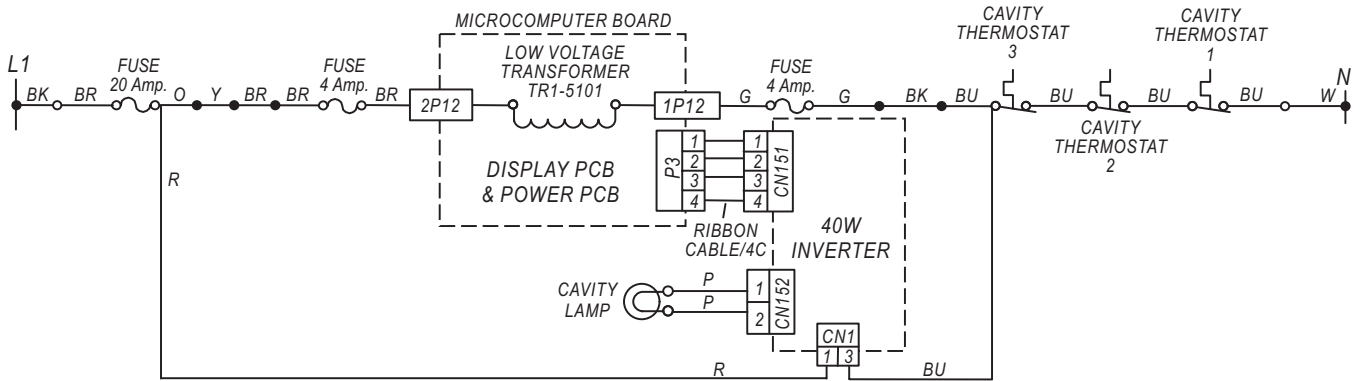

## COOKTOP LAMP ON (VARIABLE LIGHT)

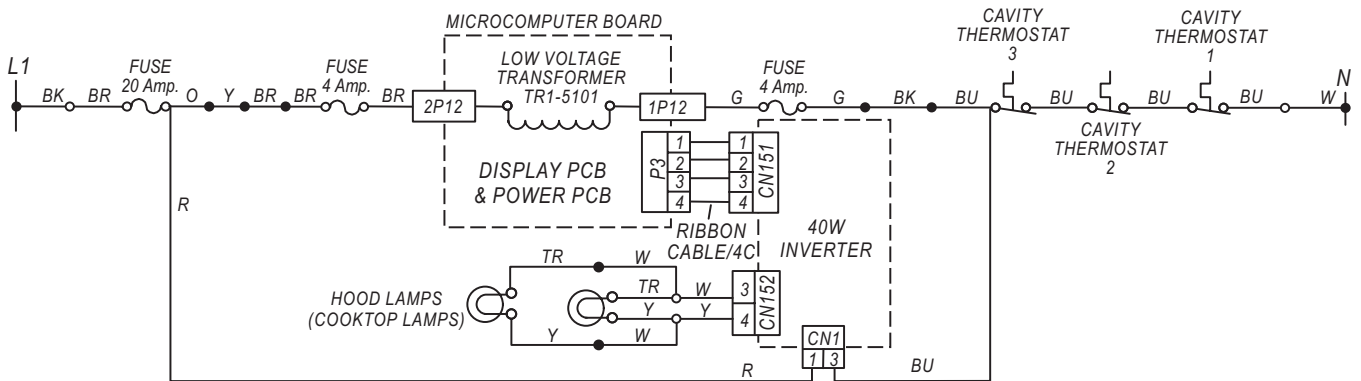

# **PRODUCT SPECIFICATIONS AND WARRANTY INFORMATION SOURCES**

***IN THE UNITED STATES:***

**FOR PRODUCT SPECIFICATIONS AND WARRANTY INFORMATION CALL:**

FOR WHIRLPOOL PRODUCTS: 1-800-253-1301  
FOR KITCHENAID PRODUCTS: 1-800-422-1230  
FOR ROPER PRODUCTS: 1-800-447-6737

**FOR TECHNICAL ASSISTANCE WHILE AT THE CUSTOMER'S HOME CALL:**

THE TECHNICAL ASSISTANCE LINE: 1-800-253-2870

**HAVE YOUR STORE NUMBER READY TO IDENTIFY YOU AS AN  
AUTHORIZED SERVICER**

**FOR LITERATURE ORDERS:**

PHONE: 1-800-851-4605

**FOR TECHNICAL INFORMATION AND SERVICE POINTERS:**

[www.servicematters.com](http://www.servicematters.com)

---

***IN CANADA:***

**FOR PRODUCT SPECIFICATIONS AND WARRANTY INFORMATION CALL:**

1-800-461-5681

**FOR TECHNICAL ASSISTANCE WHILE AT THE CUSTOMER'S HOME CALL:**

THE TECHNICAL ASSISTANCE LINE: 1-800-488-4791

**HAVE YOUR STORE NUMBER READY TO IDENTIFY YOU AS AN  
AUTHORIZED SERVICER**

**KitchenAid®**  
FOR THE WAY IT'S MADE.®

