

KitchenAid

TECHNICAL EDUCATION

27" & 30" ELECTRIC BUILT-IN MICROWAVE/OVEN COMBINATION



MODELS: KEMS378S & KEMS308S

JOB AID 4317410

FORWARD

This KitchenAid Job Aid “27” & 30” Electric Built-In Microwave/Oven Combination” (Part No. 4317410), provides the In-Home Service Professional with information on the installation, operation, and service of the 27” & 30” Electric Built-In Microwave/Oven Combination. For specific information on the model being serviced, refer to the “Use and Care Guide,” or “Tech Sheet” provided with the oven.

The Wiring Diagram and Strip Circuits used in this Job Aid are typical and should be used for training purposes only. Always use the Wiring Diagram supplied with the product when servicing the oven.

GOALS AND OBJECTIVES

The goal of this Job Aid is to provide information that will enable the In-Home Service Professional to properly diagnose malfunctions and repair the 27” & 30” Electric Built-In Microwave/Oven Combination.

The objectives of this Job Aid are to:

- Understand and follow proper safety precautions.
- Successfully troubleshoot and diagnose malfunctions.
- Successfully perform necessary repairs.
- Successfully return the oven to its proper operational status.

WHIRLPOOL CORPORATION assumes no responsibility for any repairs made on our products by anyone other than authorized In-Home Service Professionals.

TABLE OF CONTENTS

Page

GENERAL	1-1
Oven Safety	1-1
Model & Serial Number Designations	1-3
Model & Serial Number Label And Tech Sheet Locations.....	1-4
Specifications	1-5
INSTALLATION INFORMATION	2-1
Installation Requirements	2-1
Installation Instructions	2-4
PRODUCT OPERATION	3-1
COMPONENT ACCESS	4-1
Component Locations	4-1
<i>Upper Oven Components</i>	4-1
Removing The User Interface And The Oven & Microwave Control Board Assemblies.....	4-2
Removing The Humidity Sensor And The Cavity Thermostat.....	4-3
Removing The Control Power And The Microwave Light Transformers	4-4
Removing The Convection Thermoactuator And The WIDE Interface Board	4-5
Removing The Monitor Fuse And The Microwave Appliance Manager	4-6
Removing The Microwave Door Interlock Switches And The Cavity Light.....	4-7
Removing The Magnetron Thermostat And The Magnetron.....	4-9
Removing The Main L1 Filter, Main L2 Filter, And Grill Thermostat.....	4-11
Removing The Magnetron Fan Motor & The Inverter	4-13
Removing The Convection Thermistor And Grill Element.....	4-16
Removing The Lower Oven Appliance Manager.....	4-18
Removing The Line Fuse Holder & Lower Oven Light Transformer	4-20
Removing The AC Terminal Block.....	4-21
Removing The Convection Thermostat, Ring Element, And Fan Motor	4-22
Removing The Turntable Motor.....	4-24
<i>Lower Oven Components</i>	4-27
Removing The Door Latch Assembly.....	4-28
Removing The Broil Element And The Oven Temperature Sensor	4-30
Removing The Convection Ring Element And The Convection Fan Motor	4-32
Removing A Halogen Light Assembly And The Meat Probe Jack	4-34
Removing The Blower Assembly, Blower Seed Resistor, And Oven Shutdown Thermal Cutoff.....	4-36
Removing The Hidden Bake Element.....	4-38
Removing The Oven Door Glass And Handle.....	4-40
Removing The Oven Door Gasket.....	4-42

	Page
COMPONENT TESTING	5-1
UPPER OVEN COMPONENTS	5-1
Humidity Sensor	5-1
Cavity Thermostat	5-1
Microwave Light Transformer	5-2
Convection Thermoactuator	5-2
Monitor Fuse	5-3
Microwave Door Interlock Switches	5-3
Magnetron Thermostat	5-4
Magnetron	5-4
Main L1 & L2 Filters	5-5
Grill & Convection Thermostats	5-5
Magnetron Fan Motor	5-6
Microwave Inverter Board	5-6
Grill Element	5-7
Lower Oven Light Transformer	5-7
Microwave Convection Ring Element	5-8
Microwave Convection Fan Motor	5-8
Turntable Motor	5-9
Measure Oven Input Current	5-9
LOWER OVEN COMPONENTS	5-10
Door Latch Assembly	5-10
Broil Element	5-11
Oven Temperature Sensor	5-11
Convection Ring Element	5-12
Convection Fan Motor	5-12
Meat Probe Jack	5-13
Blower Motor	5-13
Blower Speed Resistor	5-14
Oven Shutdown Thermal Cutoff (TCO)	5-14
Hidden Bake Element	5-15
DIAGNOSTICS & TROUBLESHOOTING	6-1
Diagnostics	6-1
Failure/Error Display Codes	6-2
Fahrenheit To Celsius Conversion	6-7
Adjust Oven Temperature Calibration	6-7
Programming The Cavity Size	6-7
Keypads	6-7
MW Power Output Test	6-8
Relay Logic - Microwave Oven	6-8
Relay Logic - Lower Oven	6-8
WIRING DIAGRAM & STRIP CIRCUITS	7-1
Wiring Diagram	7-1
Strip Circuits	7-2

GENERAL OVEN SAFETY

Your safety and the safety of others are very important.

We have provided many important safety messages in this manual and on the appliance. Always read and obey all safety messages.



This is the safety alert symbol.

This symbol alerts you to potential hazards that can kill or hurt you and others.

All safety messages will follow the safety alert symbol and either the word “DANGER” or “WARNING.” These words mean:

! DANGER

You can be killed or seriously injured if you don't immediately follow instructions.

! WARNING

You can be killed or seriously injured if you don't follow instructions.

All safety messages will tell you what the potential hazard is, tell you how to reduce the chance of injury, and tell you what can happen if the instructions are not followed.

PRECAUTIONS TO BE OBSERVED BEFORE AND DURING SERVICING TO AVOID POSSIBLE EXPOSURE TO EXCESSIVE MICROWAVE ENERGY

- a.** Do not operate or allow the oven to be operated with the door open.
- b.** Make the following safety checks on all ovens to be serviced before activating the magnetron or other microwave source, and make repairs as necessary:
 - 1. Interlock Operation
 - 2. Proper Door Closing
 - 3. Seal and Sealing Surfaces (Arcing, Wear and Other Damage)
 - 4. Damage to or Loosening of Hinges and Latches
 - 5. Evidence of Dropping or Abuse
- c.** Before turning on microwave power for any service test or inspection within the microwave generating compartments, check the magnetron, waveguide or transmission line and cavity for proper alignment, integrity and connections.
- d.** Any defective or misadjusted components in the interlock, monitor, door seal, and microwave generation, and transmission systems shall be repaired, replaced, or adjusted by procedures described in service manual before the oven is released to the owner.
- e.** A microwave leakage check to verify compliance with the Federal performance standard should be performed on each oven prior to release to the owner.
- f.** Do not attempt to operate the oven if the door glass is broken.

MODEL & SERIAL NUMBER DESIGNATIONS

MODEL NUMBER	K	EM	S	30	8	S	SS	0
PRODUCT GROUP K = KITCHENAID								
PRODUCT IDENTIFICATION EB = ELECTRIC BUILT-IN OVEN EH = ELECTRIC BUILT-IN HI SPEED COMBO EM = ELECTRIC BUILT-IN MICRO COMBO EW = ELECTRIC WARMING OVEN/DRAWER GB = GAS BUILT-IN OVEN GM = GAS BUILT-IN MICRO COMBO OVEN								
MERCHANDISING SCHEME A = ARCHITECT C = FLUSH LOOK D = DRAWER I = IMPERIAL N = INTERNATIONAL COLLECTION EUROPEAN S = SUPERBA V = VBL PRO LINE SERIES								
CAPACITY / SIZE / SERIES / CONFIGURATION <i>1ST POSITION</i> <i>2ND POSITION</i> 1 = SINGLE OVEN 4 = 24" WIDE 2 = DOUBLE OVEN 6 = 36" WIDE 3 = COMBO OVEN 7 = 27" WIDE 5 = MINI OVEN 0 = 30" WIDE 6 = COMBO W/MINI OVEN								
FEATURE CODE 0 = STANDARD FEATURES 1 = STANDARD FEATURES / ELEC COOK 2 = INDOOR / OUTDOOR FEATURES 5 = DELUXE FEATURES 6 = DELUXE FEATURES / ELEC. CLOCK 7 = DELUXE FEATURES / THERMAL CONVECTION 8 = DOUBLE THERMAL CONVECTION 9 = MULTI-MODE								
YEAR OF INTRODUCTION S = 2006								
COLOR CODE BL = BLACK SS = STAINLESS STEEL BT = BISCUIT WH = WHITE								
ENGINEERING CHANGE (0, 1, 2, ETC.)								

SERIAL NUMBER	X	T	41	01002
DIVISION RESPONSIBILITY X = OXFORD				
YEAR OF PRODUCTION T = 2006				
WEEK OF PRODUCTION 41 = 41ST WEEK				
PRODUCT SEQUENCE NUMBER				

MODEL & SERIAL NUMBER LABEL AND TECH SHEET LOCATIONS

The Model/Serial Number label and Tech Sheet locations are shown below.

**Tech Sheet Location
(Under Top Cover)**

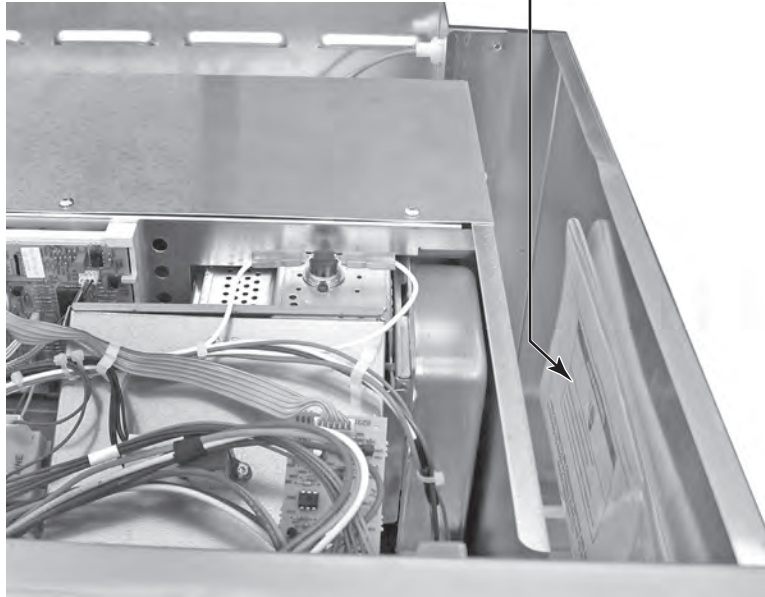

**Model & Serial Number
Label Location**

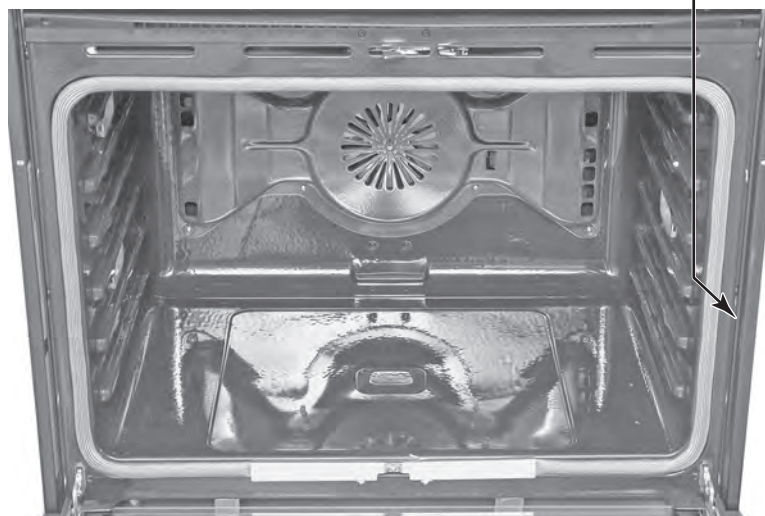

SPECIFICATIONS

Model Number	KEMS378SBL, BT, SS, WH	KEMS308SBL, BT,SS,WH
Model Description	MW/BI Combo	MW/BI Combo
Size - Configuration	27"	30"
Feature Level/Series	Superba	Superba
Predecessor Model (Model This Model Replaces)	KEMC377KBL/KEMC378KBL/ KEHC379JBL	KEMC307KBL/KEMC308KBL/ KEHC309JBL
Dimensions		
Exterior Dimensions		
Overall Height	42"	42"
Overall Width	26-3/4"	29-3/4"
Overall Depth (Includes Hdw/Handle)	26"	26"
Depth w/Door Open 90°	43-3/4"	43-3/4"
Door Swing	15-3/8"	15-3/8"
Cutout Dimensions		
Cutout Height (Measure or Min/Max)	41-1/4"	41-1/4"
Cutout Width (Measure or Min/Max)	25-1/2"	28-1/2"
Cutout Depth (Measure or Min/Max)	23-1/4"	23-1/4"
Other Dimensions		
Conduit Size (Length/Diameter)	57" / 1/2"	57" / 1/2"
Ratings		
Electric Voltage/Phase/Frequency (Hz)	208V / 240V / 2-3 / 60	208V / 240V / 2-3 / 60
Total Connected Load in kW		
240 Volts	11.35	11.21
208 Volts	9.24	9.10
240/120V AC	11.42	11.42
Circuit Amps	40	40
Upper/Microwave Oven		
Distribution Type	Lateral Feed w/o Stirrer	Lateral Feed w/o Stirrer
Magnetron Type	Inverter	Inverter
Temperature Sensor	Yes	Yes
Microwave Timer	Yes	Yes
Timer Limits (Min:Sec)	99:99	99:99
Timer Control Type	Electronic	Electronic
Timer Scale	Linear (Digital)	Linear (Digital)
MW Cavity Material	Stainless	Stainless

Model Number	KEMS378SBL, BT, SS, WH	KEMS308SBL, BT,SS,WH
Interior		
Lower/Main Oven		
Cleaning System	Self Cleaning	Self Cleaning
Main Oven Liner Finish	Blue Porcelain	Blue Porcelain
Main Oven Dimensions		
Main Oven Volume (cu ft)	3.6	4.1
Main Oven Height	16"	16"
Main Oven Width	22"	25"
Main Oven Depth	17-5/8"	17-5/8"
Oven Light #/Location	3 Side Halogen	3 Side Halogen
Main Electric Oven		
Main Hidden Bake Element	Yes	Yes
Main Oven Electric Element Output		
Bake (w@240/208)	2000 Watt	2000 Watt
Broil Inner Element (w@240/208)	1800 Watt	1800 Watt
Broil Outer Element (w@240/208)	1450 Watt	1450 Watt
Convection (w@240/208)	1600 Watt	1600 Watt
Accessories		
Baking Rack	Yes	Yes
Convection Grid	Yes	Yes
Broiler Pan & Grid Part/Comment	8303973BU/4457277	8303973BU/4457277
Roasting Rack Part/Comment	3181534	3181534
Teflon Coated Crisp Pan Kit	Yes	Yes
Steam Vessel	Yes	Yes
Miscellaneous		
Product Literature		
Installation Instructions Part #	8304337	8304377
Service Manual Part #	4317410	4317410
Tech Sheet Part #	8304098 (E) 8304417 (F)	8304098 (E) 8304417 (F)
Use & Care Guide Microwave Part #	8304369	8304369
Use & Care Guide Oven Part #	8304358	8304358
Agency Approvals	UL, CUL	UL, CUL
Installation Hardware	Yes	Yes
Warranty		
Limited	12 Mo.	12 Mo.
Extended		
Electronic Controls	60 Mo. Parts Only	60 Mo. Parts Only
Electrical Elements	60 Mo. Parts Only	60 Mo. Parts Only
Magnetron	60 Mo. Parts Only	60 Mo. Parts Only
Stainless Steel Liner/Door (Microwave)	120 Mo. Parts Only	120 Mo. Parts Only

INSTALLATION INFORMATION

INSTALLATION REQUIREMENTS

TOOLS AND PARTS

Gather the required tools and parts before starting installation. Read and follow the instructions provided with any tools listed here.

Tools needed

- Phillips screwdriver
- Measuring tape
- Hand or electric drill (for wall cabinet installations)
- 1" (25 mm) drill bit (for wall cabinet installations)
- Level

Parts needed

- UL listed or CSA approved conduit connector
- UL listed wire connectors

Parts supplied

- # 8-14 x 1" screws - single oven (2), double oven (4)
- Bottom vent (supplied on some models)
- Two # 8-18 x 3/8" screws - bottom vent (supplied on some models)

Check local codes. Check existing electrical supply. See "Electrical Requirements," page 2-2. It is recommended that all electrical connections be made by a licensed, qualified electrical installer.

LOCATION REQUIREMENTS

Make sure you have everything needed for correct installation. It is the responsibility of the installer to comply with the installation clearances specified in these instructions.

IMPORTANT: Observe all governing codes and ordinances.

- Cabinet opening dimensions that are shown must be used. Given dimensions provide minimum clearance with oven.

- Recessed installation area must provide complete enclosure around the recessed portion of the oven.
- Grounded electrical supply is required. See "Electrical Requirements," page 2-2.
- Electrical supply junction box should be located 3" (7.6 cm) maximum below the support surface when the oven is installed in a wall cabinet. A 1" (2.5 cm) minimum diameter hole should have been drilled in the right rear or left rear corner of the support surface to pass the appliance cable through to the junction box.
- Oven support surface must be solid, level and flush with bottom of cabinet cutout. Floor must be able to support a total weight (microwave and built-in oven) of 238 lbs (108 kg).

Product Dimensions

27" (68.6 cm) and 30" (76.2 cm) Ovens

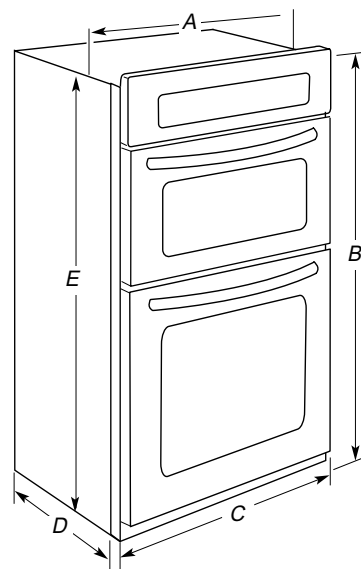

27" (68.6 cm) models

- A. 25-5/16" (64.3 cm) recessed width
- B. 42-5/16" (107.5 cm) overall height
- C. 26-3/4" (67.9 cm) overall width
- D. 23" (58.4 cm) max. recessed depth
- E. 40-3/4" (103.5 cm) recessed height

30" (76.2 cm) models

- A. 28-5/16" (71.9 cm) recessed width
- B. 42-5/16" (107.5 cm) overall height
- C. 29-3/4" (75.6 cm) overall width
- D. 23" (58.4 cm) max. recessed depth
- E. 40-3/4" (103.5 cm) recessed height

Cabinet Dimensions

27" (68.6 cm) and 30" (76.2 cm) Ovens

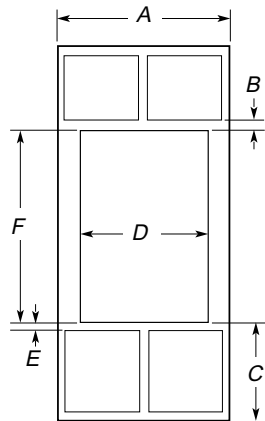

27" (68.6 cm) models

- A. 27" (68.6 cm) min. cabinet width
- B. 1" (2.5 cm) top of cutout to bottom of upper cabinet door
- C. 19-1/4" (48.9 cm) bottom of cutout to floor
- D. 25-1/2" (64.8 cm) cutout width
- E. 1-1/2" (3.8 cm) min. bottom of cutout to top of cabinet door
- F. 41-1/4" (104.8 cm) cutout height

30" (76.2 cm) models

- A. 30" (76.2 cm) min. cabinet width
- B. 1" (2.5 cm) top of cutout to bottom of upper cabinet door
- C. 19-1/4" (48.9 cm) bottom of cutout to floor
- D. 28-1/2" (72.4 cm) cutout width
- E. 1-1/2" (3.8 cm) min. bottom of cutout to top of cabinet door
- F. 41-1/4" (104.8 cm) cutout height

Cabinet Side View

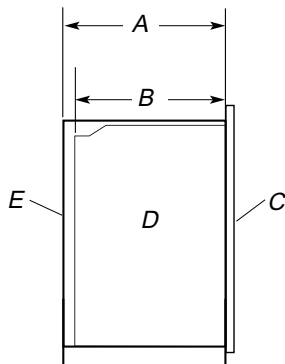

- A. 23-1/4" (59.1 cm) min. cutout depth
- B. 23" (58.4 cm) recessed oven depth
- C. Oven front
- D. Recessed oven
- E. Cabinet

ELECTRICAL REQUIREMENTS

If codes permit and a separate ground wire is used, it is recommended that a qualified electrical installer determine that the ground path and wire gauge are in accordance with local codes.

It is not recommended to ground to a gas pipe. Check with a qualified electrical installer if you are not sure the oven is properly grounded.

It is not recommended to have a fuse in the neutral or ground circuit.

This oven must be connected to a grounded metal, permanent wiring system.

Be sure that the electrical connection and wire size are adequate and in conformance with the National Electrical Code, ANSI/NFPA 70-latest edition or CSA Standards C22.1-94, Canadian Electrical Code, Part 1 and C22.2 No. O-M91-latest edition, and all local codes and ordinances.

A copy of the above code standards can be obtained from:

National Fire Protection Association
One Batterymarch Park
Quincy, MA 02269

CSA International
8501 East Pleasant Valley Road
Cleveland, OH 44131-5575

Electrical Connection

To properly install your oven, you must determine the type of electrical connection you will be using and follow the instructions provided for it here.

- Oven must be connected to the proper electrical voltage and frequency as specified on the model/serial number rating plate. The model/serial number rating plate is located at the bottom of the right-hand mounting rail. See the following illustration.

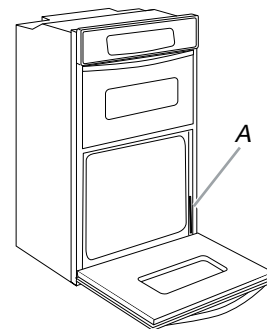

A. Model/serial number plate

- Models rated from 7.3 to 9.6 kW at 240 volts (5.5 to 7.2 kW at 208 volts) require a separate 40-amp circuit. Models rated at 7.2 kW and below at 240 volts (5.4 kW and below at 208 volts) require a separate 30-amp circuit.
 - A time-delay fuse or circuit breaker is recommended.
 - Connect directly to the fused disconnect (or circuit breaker box) through flexible, armored or nonmetallic sheathed, copper cable (with grounding wire). See “Make Electrical Connection,” page 2-5.
 - Flexible cable from the oven should be connected directly to the junction box.
 - Fuse both sides of the line.
 - Do not cut the conduit. The length of conduit provided is for serviceability of the oven.
 - A UL listed or CSA approved conduit connector must be provided.
 - If the house has aluminum wiring follow the procedure below:
 1. Connect a section of solid copper wire to the pigtail leads.
 2. Connect the aluminum wiring to the added section of copper wire using special connectors and/or tools designed and UL listed for joining copper to aluminum.
- Follow the electrical connector manufacturer’s recommended procedure. Aluminum/copper connection must conform with local codes and industry accepted wiring practices.

INSTALLATION INSTRUCTIONS

PREPARE BUILT-IN MICROWAVE/ OVEN COMBINATION

1. Decide on the final location for the oven. Locate existing wiring to avoid drilling into or severing wiring during installation.

⚠ WARNING

Excessive Weight Hazard

Use two or more people to move and install oven.

Failure to do so can result in back or other injury.

2. To avoid floor damage, set the oven onto cardboard prior to installation. Do not use handle or any portion of the front frame for lifting.
3. Remove the shipping materials and tape from the oven.
4. Remove the hardware package from inside the bag containing literature.
5. Remove and set aside racks and other parts from inside the oven.
6. Move oven and cardboard close to the oven's final location.

REMOVE OVEN DOOR

IMPORTANT: Use both hands to remove oven door.

1. Open the oven door.
2. Locate the oven door latches in both corners of the oven door, and rotate the latches forward to the unlocked position.

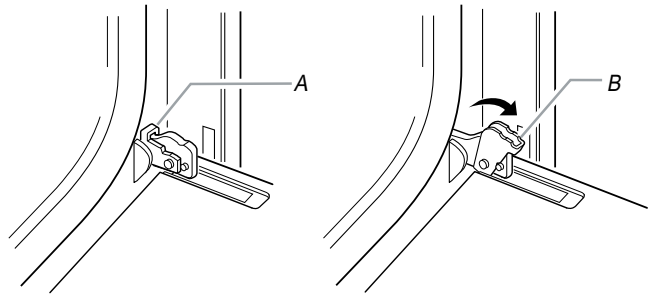

A. Oven door latch in locked position

B. Oven door latch in unlocked position

3. Grasp the edges of the oven door with both hands and close the oven door until it will no longer close. Lift and pull oven door toward you and remove. Set the oven door aside on a covered work surface.

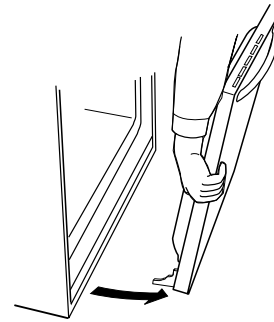

MAKE ELECTRICAL CONNECTION

! WARNING



Electrical Shock Hazard

Disconnect power before servicing.

Use 8 gauge solid copper wire.

Electrically ground oven.

Failure to follow these instructions can result in death, fire, or electrical shock.

This oven is manufactured with a neutral (white) power supply wire and a cabinet-connected green (or bare) ground wire twisted together.

1. Disconnect power.
2. Feed the flexible cable conduit from the oven through the opening in the cabinet.
3. Remove junction box cover if it is present.
4. Install a UL listed or CSA approved conduit connector to the junction box.

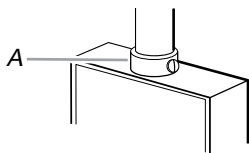

A. UL listed or CSA approved conduit connector

5. Route the flexible cable conduit from the oven to the junction box through a UL listed or CSA approved conduit connector.
6. Tighten screws on conduit connector.
7. See "Electrical Connection Options Chart" to complete installation for your type of electrical connection.

Electrical Connection Options Chart

If your home has:

Go to section:

4-wire

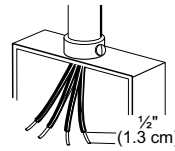

4-wire Cable from Home Power Supply

3-wire

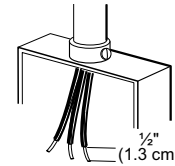

3-wire Cable from Home Power Supply

4-Wire Cable from Home Power Supply

IMPORTANT: Use the 4-wire cable from home power supply in the U.S. where local codes do not allow grounding through neutral, New Branch circuit installations (1996 NEC), mobile homes and recreational vehicles, new construction and in Canada.

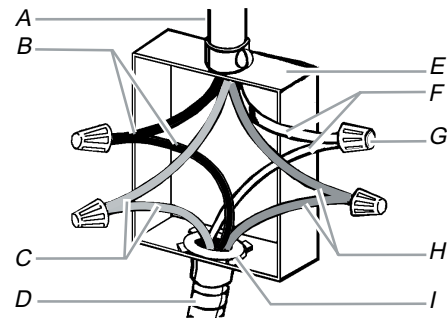

A. Cable from home power supply
B. Black wires
C. Red wires
D. 4-wire flexible cable from oven
E. Junction box

F. White wires
G. UL listed wire connectors
H. Green (or bare) ground wires
I. UL listed or CSA approved conduit connector

1. Connect the 2 black wires (B) together using a UL listed wire connector.
2. Connect the 2 red wires (C) together using a UL listed wire connector.
3. Untwist white wire from green (or bare) ground wire coming from the oven.
4. Connect the 2 white wires (F) together using a UL listed wire connector.
5. Connect the green (or bare) ground wire (H) from the oven cable to the green (or bare) ground wire (in the junction box) using a UL listed wire connector.
6. Install junction box cover.

3-Wire Cable from Home Power Supply - U.S. Only

IMPORTANT: Use the 3-wire cable from home power supply where local codes permit a 3-wire connection.

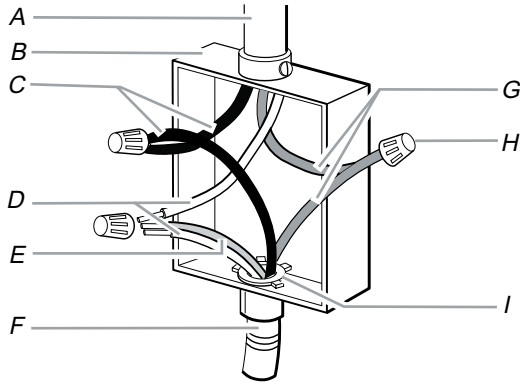

- | | |
|--|--|
| A. Cable from home power supply | F. 4-wire flexible cable from oven |
| B. Junction box | G. Red wires |
| C. Black wires | H. UL listed wire connectors |
| D. White wires | I. UL listed or CSA approved conduit connector |
| E. Green (or bare) ground wire (from oven) | |

1. Connect the 2 black wires (C) together using a UL listed wire connector.
2. Connect the 2 white wires (D) and the green (or bare) ground wire (of the oven cable) using a UL listed wire connector.
3. Connect the 2 red wires (G) together using a UL listed wire connector.
4. Install junction box cover.

INSTALL OVEN

! WARNING

Excessive Weight Hazard

Use two or more people to move and install oven.

Failure to do so can result in back or other injury.

1. Using 2 or more people, lift oven partially into cabinet cutout using the oven opening as an area to grip.

NOTE: Push against seal area of oven front frame when pushing oven into cabinet. Do not push against outside edges.

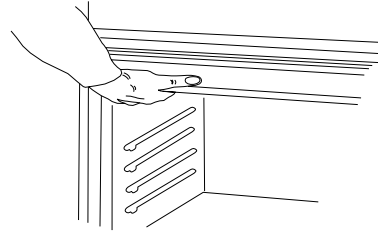

2. Push against seal area of front frame to push oven into cabinet.

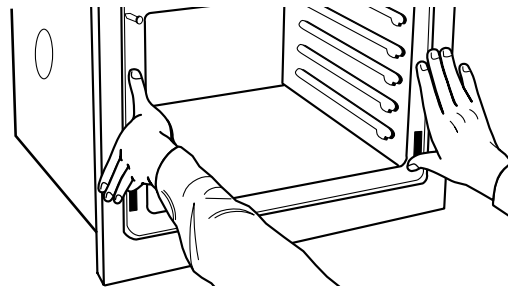

3. Push oven completely into cabinet and center oven into cabinet cutout.

- Securely fasten oven to cabinet using the #8-14 x 1" screws (2 for single oven, 4 for double oven) provided. Insert the screws through holes in mounting rails. Do not overtighten screws.

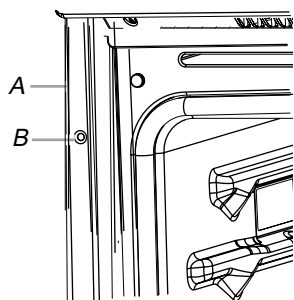

A. Mounting rail
B. Insert #8-14 x 1" screw.

- On some models, the oven vent is taped to the side of the oven.

With one #8-14 x 3/8" screw for each side of the vent, fasten vent securely to the oven.

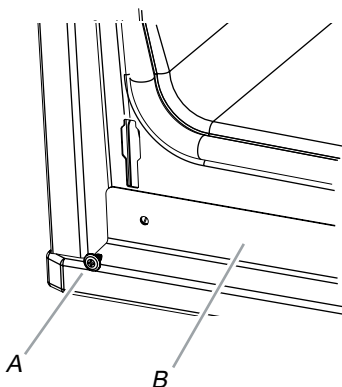

A. #8-14 x 3/8" screw
B. Oven vent

- Replace oven racks.
- Replace oven door by inserting ends of hinges into hinge slots in the oven frame.
- Push hinges in as far as they will go and open the oven door. You should feel the oven door drop into place.
- Rotate both hinge latches back to the locked position.

- Check that the door is free to open and close. If it is not, repeat the removal and installation procedures. See "Remove Oven Door," page 2-4.
- Reconnect power.
- Display panel will light briefly, and "PF" should appear in the display.
- If display panel does not light, please reference the "Assistance or Service" section of the Use and Care Guide or contact the dealer from whom you purchased your oven.

COMPLETE INSTALLATION

- Check that all parts are now installed. If there is an extra part, go back through the steps to see which step was skipped.
- Check that you have all of your tools.
- Dispose of/recycle all packaging materials.
- For oven use and cleaning, read the Use and Care Guide.

Check Operation of Lower Oven

- Turn power on.
- When "CLOCK ENTER TIME" appears in the lower oven display touch START.
- Touch BROIL.
- Touch START.

If oven does not operate, check the following:

- Household fuse is intact and tight; or circuit breaker has not tripped.
 - Electrical supply is connected.
 - See "Troubleshooting" section in the Use and Care Guide.
- When oven has been on for 5 minutes, feel for heat. If you do not feel heat or if an error code ("F" followed by a number plus "E" followed by a number) appears in the display, turn off the oven and contact a qualified technician.
 - Touch LOWER OVEN OFF.

Check Operation of Microwave Oven

1. Fill a microwave-safe container with 1 cup (250 mL) of water and place container inside microwave oven. Close door firmly.
2. Set microwave oven cook time to “2:00” minutes.
3. Touch START. The interior microwave oven light should be on, and the remaining cooking time should be displayed in the upper oven display.

If microwave does not operate, check the following:

- Household fuse is intact and tight; or circuit breaker has not tripped.
- Electrical supply is connected.
- See “Troubleshooting” section in the Use and Care Guide.
- When display reads “1:00” minute, open microwave oven door. The microwave should stop cooking. Close door firmly. The interior microwave oven light should turn off.

4. Touch START to resume preset cycle. The microwave oven should begin cooking, and the microwave oven interior light should be on.

Let microwave oven complete cooking time. A tone will sound 3 times at the end of the cooking time, and the microwave oven will shut off.

5. Open microwave oven door and slowly remove container. Water in container should be hot.

If you need Assistance or Service:

Please reference the “Assistance or Service” section of the Use and Care Guide or contact the dealer from whom you purchased your built-in and microwave ovens.

PRODUCT OPERATION

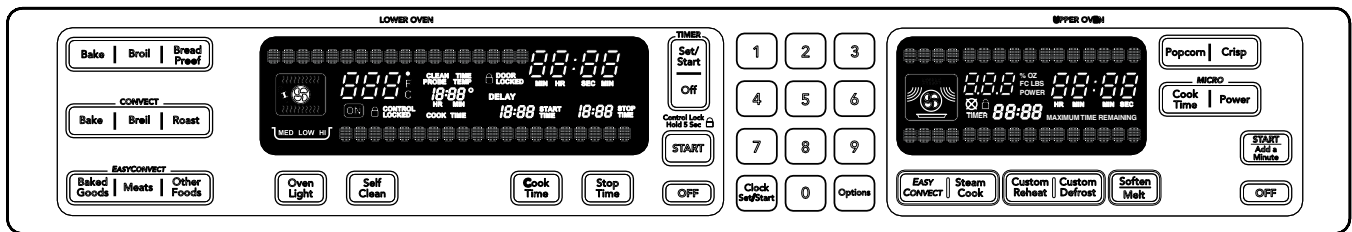
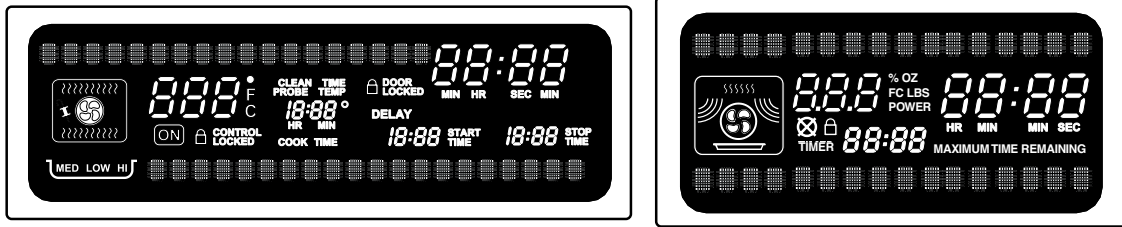

ELECTRONIC OVEN CONTROL

CONTROL LOCK

The Control Lock shuts down the control panel keys to avoid unintended use of the oven. The Control Lock will remain set after a power failure, if set before the power failure occurs.

When the control is locked, only the TIMER SET/START, TIMER OFF and OVEN LIGHT keys will function.

The Control Lock is preset unlocked, but can be locked.

To Lock Control: Touch and hold START for approximately 5 seconds, until “control locked” appears on the lower text line and a lock icon appears in the display.

To Unlock Control: Repeat to unlock and remove “control locked” and lock icon from the display.

DONENESS

Doneness may be adjusted to more done, less done, or back to normal doneness (default) for all automatic cooking functions except Popcorn, EasyConvect™, Custom Reheat (manual), Custom Defrost (manual) and Steam (manual).

To Change Doneness Setting:

During programming, before touching START, touch POWER once for MORE, twice for LESS or 3 times for NORMAL.

SABBATH MODE

The Sabbath Mode sets the oven to remain on in a bake setting until turned off. A timed Sabbath Mode can also be set to keep the oven on for only part of the Sabbath.

When the Sabbath Mode is set, only the number and start keys will function, no tones will sound, and the displays will not show messages or temperature changes. The heat sources icons will appear lit on the lower oven display throughout the Sabbath Mode.

When the Sabbath Mode is set the lower oven is disabled and no function is allowed. When the oven door is opened or closed, the oven light will not turn on or off and the heating elements will not turn on or off immediately.

If a power failure occurs when the Sabbath Mode is set, the oven will remain in Sabbath Mode but will no longer be actively cooking. The “ON” indicator will no longer be lit. Touch OFF to return to normal operating mode (non-Sabbath Mode, not cooking).

To Activate:

Before the Sabbath Mode can be regularly set, the oven must first be enabled with a one time only setup.

1. Open the oven door.
2. Touch OFF.
3. Touch the number keys 7, 8, 9, 6, in this order.
4. Touch START to activate. “SABBATH ENABLED” will appear on the display.
5. Touch OFF to clear the display.
6. Close oven door.

To Deactivate:

The oven can be disabled of the ability to set the Sabbath Mode by repeating the previous steps. See the “To Activate” section. When disabled “SABBATH DISABLED” will appear on the display. The Sabbath Mode cannot be regularly set until re-enabled.

CONVECTION BROIL

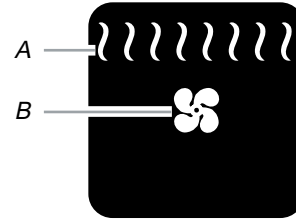

A. Broil heat
B. Convection fan

During convection broiling, the broil elements will cycle on and off in intervals to maintain oven temperature, while the fan constantly circulates the hot air.

The temperature is preset at 450°F (232°C), but can be changed to a different temperature. Cooking times will vary depending on the rack position and temperature and may need to be adjusted.

If the oven door is opened during convection broiling, fan turns off immediately when door is opened and turns on again immediately when door is closed. Broil elements will turn off approximately 30 seconds after the door is opened. They will turn on again approximately 30 seconds after the door is closed.

TEMPERATURE PROBE

⚠ WARNING

Burn Hazard Use an oven mitt to remove temperature probe. Do not touch broil element. Failure to follow these instructions can result in burns.

The temperature probe accurately measures the internal temperature of meat, poultry and casseroles with liquid and should be used in determining the doneness of meat and poultry. It should not be used during full and center broiling, convection broiling, dehydrating or proofing bread.

Always unplug and remove the temperature probe from the oven when removing food.

DEHYDRATING

(on convection models, closed door)

Dehydration is a method used to preserve food. Various factors, such as the quality of the fresh food, pretreatment techniques, the size and thickness of the food, and the climate may affect the finished product.

During dehydration, heat is used to force out moisture and air circulation is used to carry the moisture away.

Refer to a reliable book or source for complete information about dehydrating and preserving foods.

NOTE: The oven will automatically turn off after 12 hours. However, some foods may take more than 12 hours to dehydrate. If this is the case, the oven will need to be restarted.

— NOTES —

COMPONENT ACCESS

This section instructs you on how to service each component inside the KitchenAid 27" & 30" Electric Built-In Microwave/Oven Combination. The upper oven components and their locations are shown below. The lower oven component locations are shown on page 4-27.

COMPONENT LOCATIONS *Upper Oven Components*

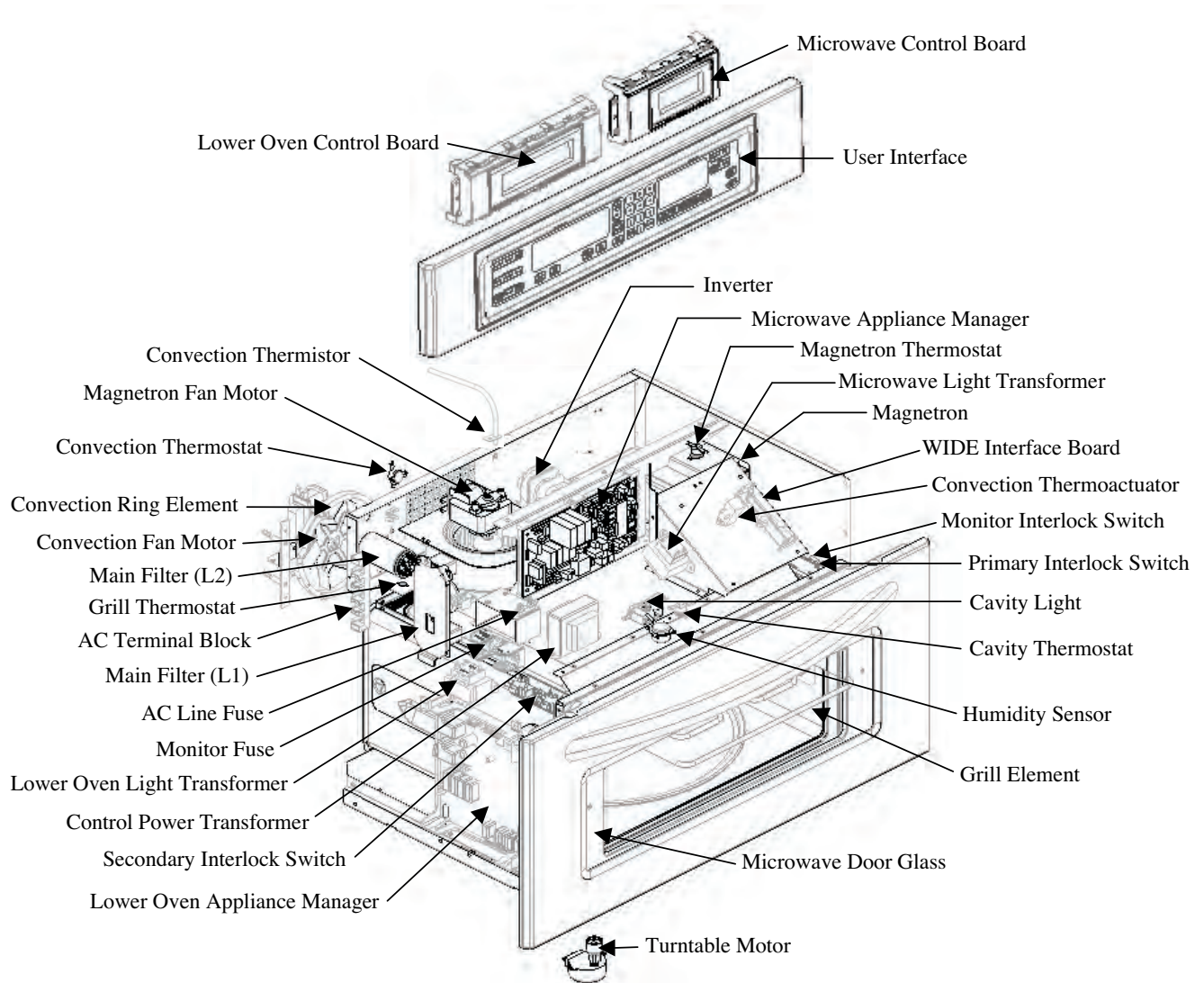

REMOVING THE USER INTERFACE AND THE OVEN & MICROWAVE CONTROL BOARD ASSEMBLIES

⚠ WARNING



Electrical Shock Hazard

Disconnect power before servicing.

Replace all parts and panels before operating.

Failure to do so can result in death or electrical shock.

1. Unplug oven or disconnect power.
2. Open the microwave oven door and remove the two flat-head screws from the bottom of the control panel frame.
3. Remove the control panel frame and close the microwave oven door.

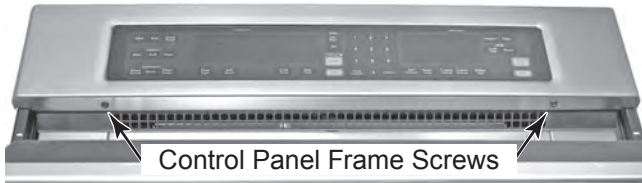

4. **To remove the user interface (UI):**
 - a) Remove the screw from the bracket on the right side of the user interface and remove the bracket.
 - b) Slide the user interface to the right, unhook it from the left bracket, and rotate the top forward and down.

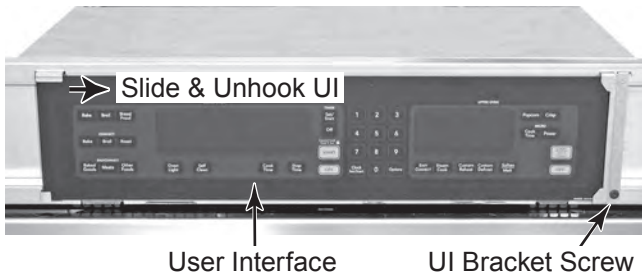

- c) Disconnect the two ribbon cable connectors from the user interface and remove the interface.

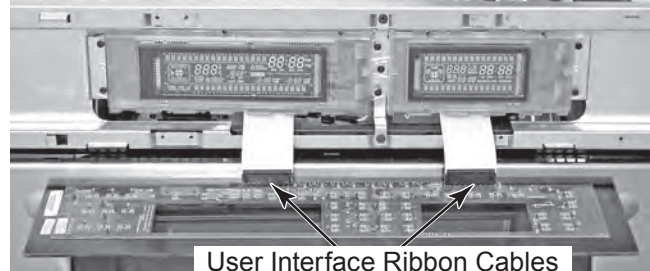

5. **To remove the oven and microwave (MW) control board assemblies:**

- a) Remove the user interface (see step 4).
- b) Remove the indicated screws from the oven or MW control board brackets.

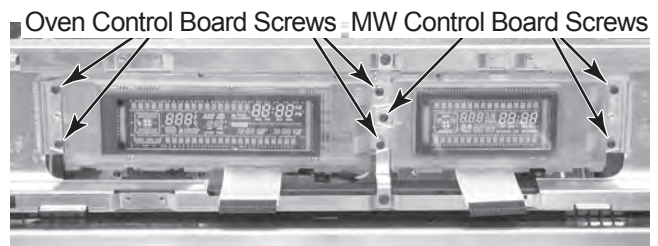

- c) Rotate the top of the MW or oven control board assembly forward and down, and disconnect the connectors from the board as follows:

- P1 (8-pin)
- P2 (5-pin)
- P40 (ribbon cable)

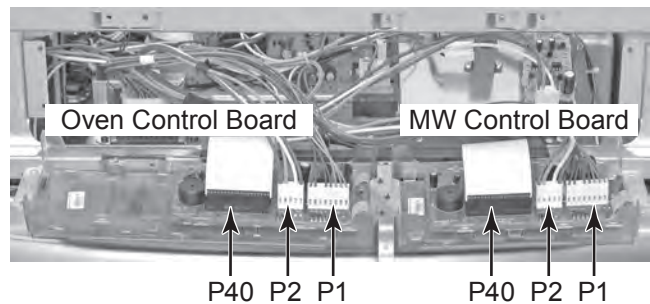

REMOVING THE HUMIDITY SENSOR AND THE CAVITY THERMOSTAT

⚠ WARNING



Electrical Shock Hazard
Disconnect power before servicing.
Replace all parts and panels before operating.
Failure to do so can result in death or electrical shock.

1. Unplug oven or disconnect power.
2. Open the microwave oven door, remove the two flat-head screws from the bottom of the control panel frame, and remove the frame.

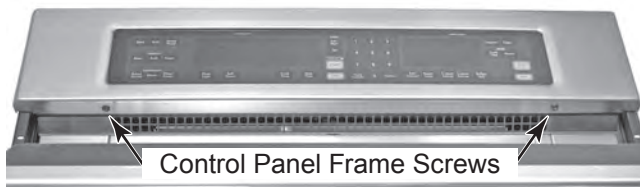

3. Remove the four screws from the front subpanel and remove the subpanel assembly.



4. Disconnect the P1 and P2 connectors from the microwave and lower oven control board connectors and set the panel assembly aside.

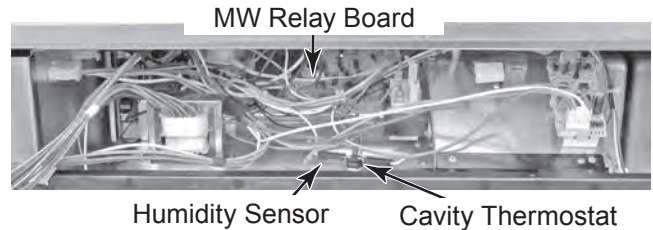
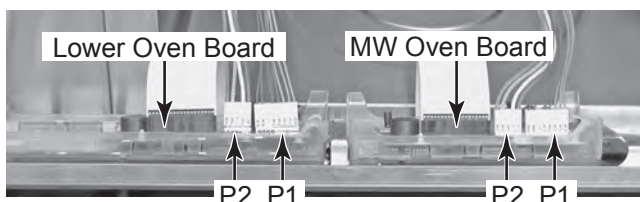

5. To remove the humidity sensor:

- a) Remove the two screws from the humidity sensor.

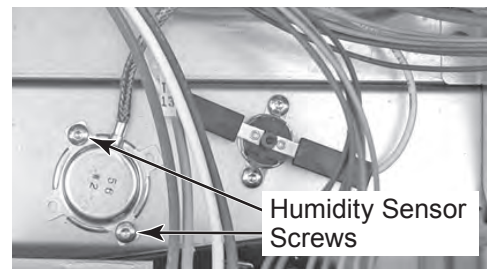

- b) Disconnect the sensor from microwave relay board connector HUM.
- c) Cut the humidity sensor cable from the harness and remove the sensor.

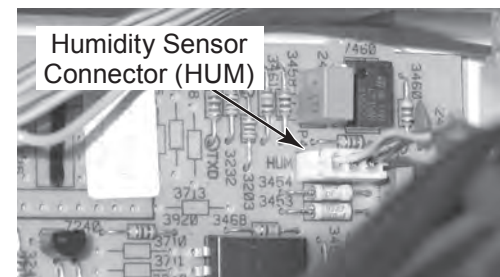

6. To remove the cavity thermostat:

- a) Remove the two screws from the cavity thermostat.
- b) Disconnect the two white wire connectors from the cavity thermostat terminals and remove the thermostat.

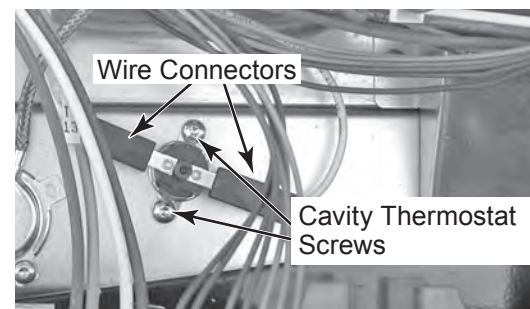

REMOVING THE CONTROL POWER AND THE MICROWAVE LIGHT TRANSFORMERS

⚠ WARNING



Electrical Shock Hazard
Disconnect power before servicing.
Replace all parts and panels before operating.
Failure to do so can result in death or electrical shock.

1. Unplug oven or disconnect power.
2. Open the microwave oven door, remove the two flat-head screws from the bottom of the control panel frame, and remove the frame.

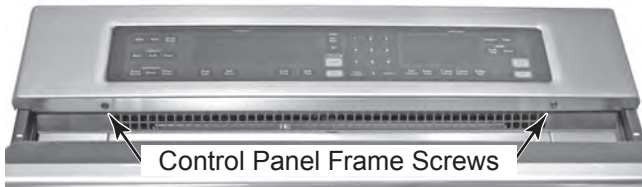

3. Remove the four screws from the front subpanel and remove the subpanel assembly.



4. Disconnect the P1 and P2 connectors from the microwave and lower oven control board connectors and set the panel assembly aside.

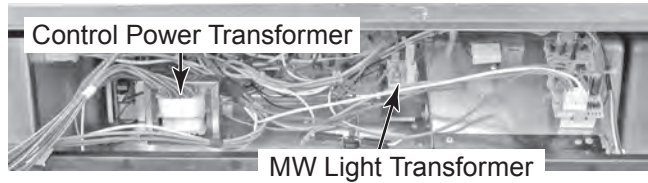
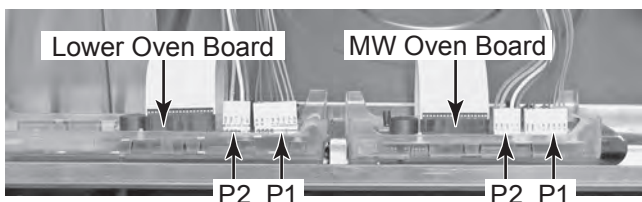

5. To remove the control power transformer:

- a) Disconnect the 2-wire transformer connector from the left side panel connector.
- b) Remove the two screws from the transformer and remove the transformer.

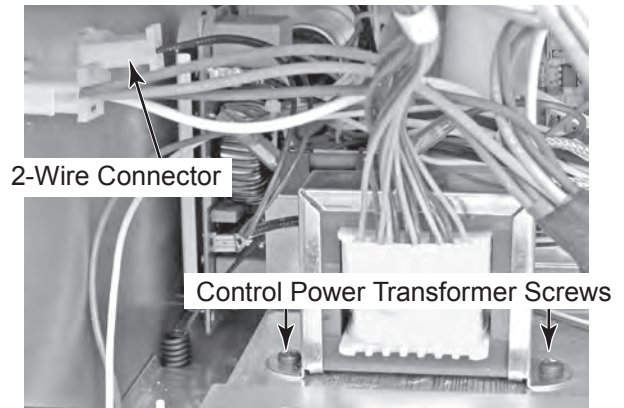

6. To remove the microwave light transformer:

- a) Disconnect the two pink wire connectors from the LOAD terminals, and the two brown wire connectors from the LINE terminals.
- b) Remove the two screws from the transformer and remove the transformer.

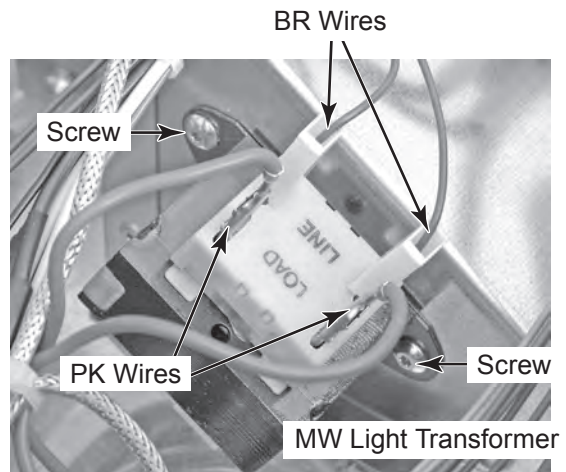

REMOVING THE CONVECTION THERMOACTUATOR AND THE WIDE INTERFACE BOARD

⚠ WARNING



Electrical Shock Hazard
Disconnect power before servicing.
Replace all parts and panels before operating.
Failure to do so can result in death or electrical shock.

1. Unplug oven or disconnect power.
2. Open the microwave oven door, remove the two flat-head screws from the bottom of the control panel frame, and remove the frame.

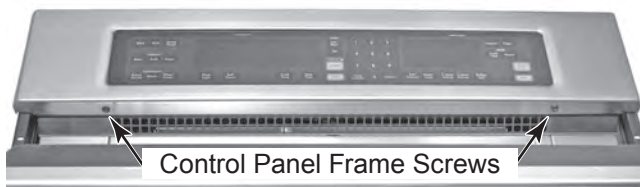

3. Remove the four screws from the front subpanel and remove the subpanel assembly.



4. Disconnect the P1 and P2 connectors from the microwave and lower oven control board connectors and set the panel assembly aside.

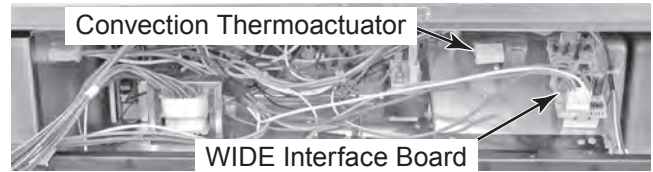
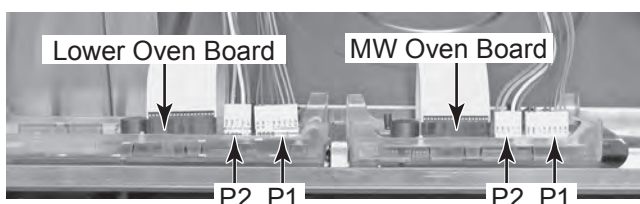

5. To remove the convection thermoactuator:
 - a) Disconnect the two wire connectors from the terminals.
 - b) Remove the two screws and remove the thermoactuator.

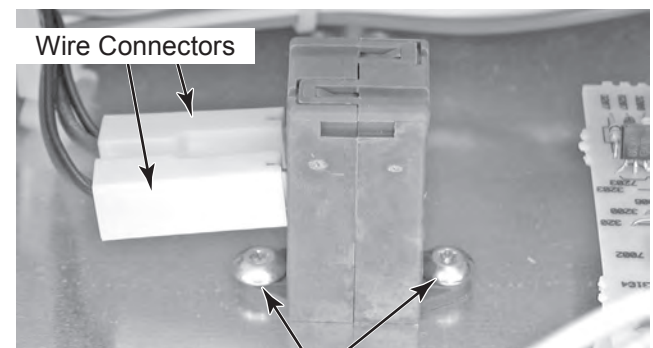

6. To remove the WIDE interface board:
 - a) Disconnect the two wire connectors at P1 and U3.
 - b) Push and unlock the tab and remove the WIDE interface board from its bracket.

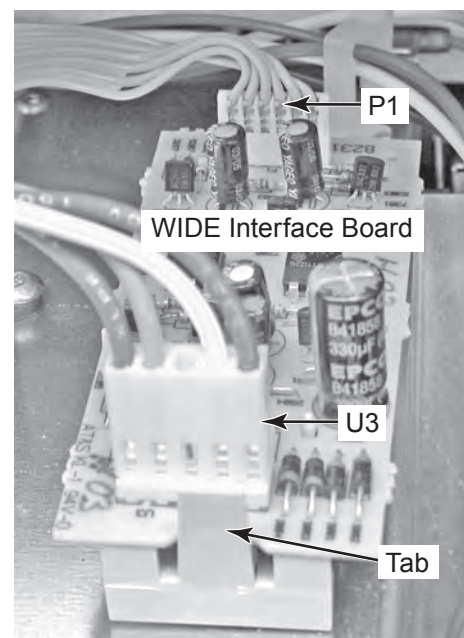

REMOVING THE MONITOR FUSE AND THE MICROWAVE APPLIANCE MANAGER

⚠ WARNING



Electrical Shock Hazard
Disconnect power before servicing.
Replace all parts and panels before operating.
Failure to do so can result in death or electrical shock.

1. Unplug oven or disconnect power.
2. Open the microwave oven door, remove the two flat-head screws from the bottom of the control panel frame, and remove the frame.

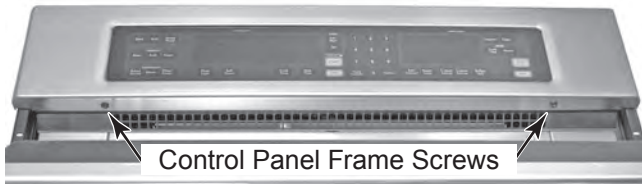

3. Remove the four screws from the front subpanel and remove the subpanel assembly.



4. Disconnect the P1 and P2 connectors from the microwave and lower oven control board connectors and set the panel assembly aside.

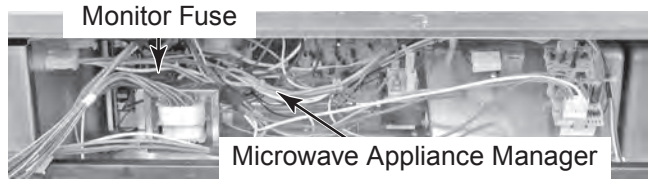
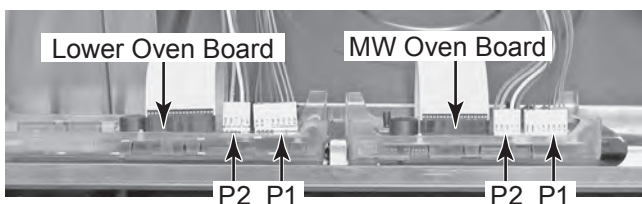

5. **To remove the monitor fuse holder:**
 - a) Remove the fuse from the fuse holder.
 - b) Disconnect the two wire connectors from the fuse holder terminals.
 - c) Remove the screw from the fuse holder and remove the fuse holder.

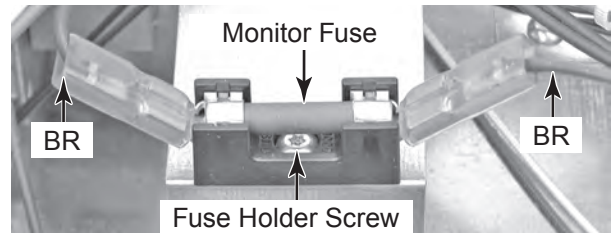

6. **To remove the microwave appliance manager:**
 - a) Remove the two screws from the left side of the board and remove the board from its holder.
 - b) Disconnect the wire connectors from the board (see below for the wiring).

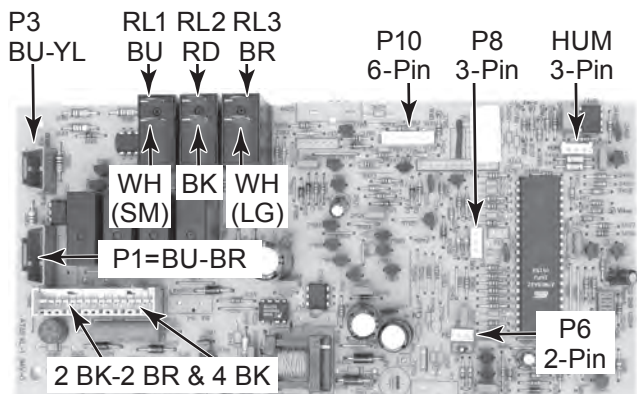
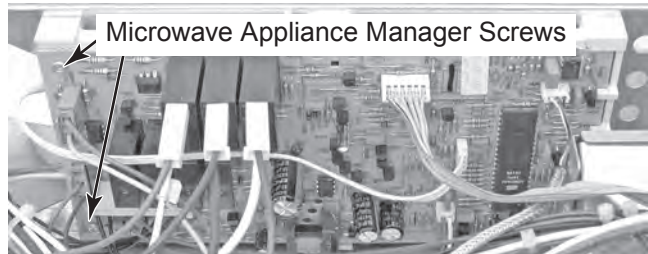

REMOVING THE MICROWAVE DOOR INTERLOCK SWITCHES AND THE CAVITY LIGHT

⚠ WARNING



Electrical Shock Hazard
Disconnect power before servicing.
Replace all parts and panels before operating.
Failure to do so can result in death or electrical shock.

1. Unplug oven or disconnect power.
2. Open the microwave oven door, remove the two flat-head screws from the bottom of the control panel frame, and remove the frame.

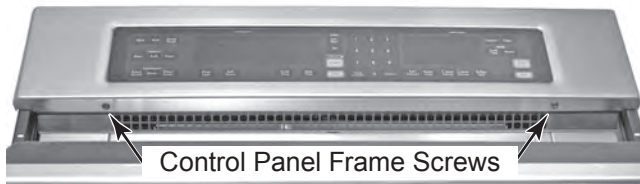

3. Remove the four screws from the front subpanel and remove the subpanel assembly.



4. Disconnect the P1 and P2 connectors from the microwave and lower oven control board connectors and set the panel assembly aside.

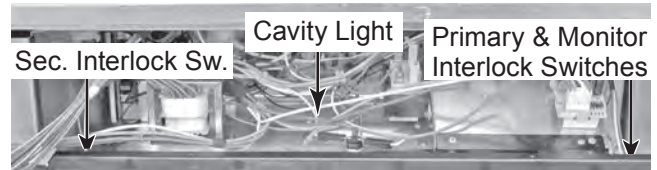
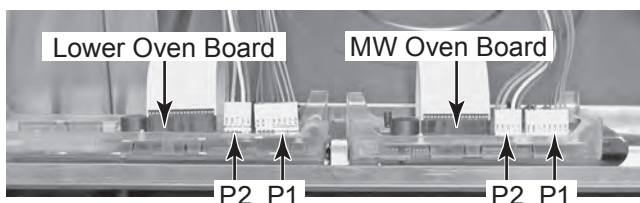

5. To remove the secondary interlock switch:

- a) Remove the two mounting bracket screws from the front of the switch holder on the left front side of the MW oven, and remove the holder.



- b) Disconnect the blue (COM) and white (N.O.) wires from the switch terminals.
- c) Raise the locking tabs and pull the switch off the pins and out of the switch holder.

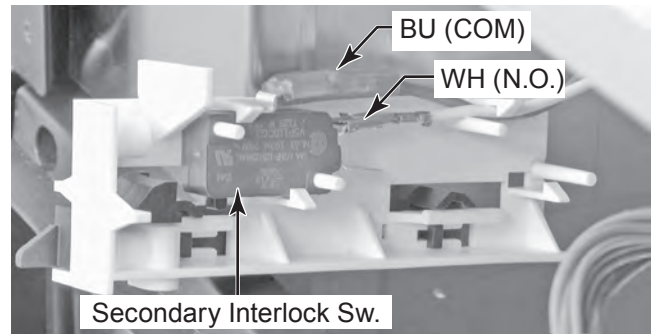

Continued on the next page.

6. **To remove the primary or monitor interlock switch:**

- a) Place the blade of a flat-blade screwdriver between the switch body and the holder. Twist the blade until the switch is free of the tabs, and remove the switch from the holder.

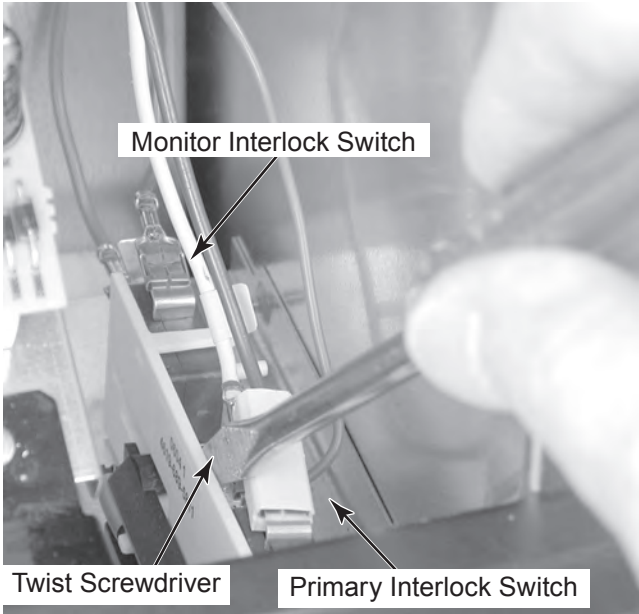

- b) *Primary (front):* Disconnect the brown (COM), white (N.O.), and blue (N.C.) wires from the switch terminals.

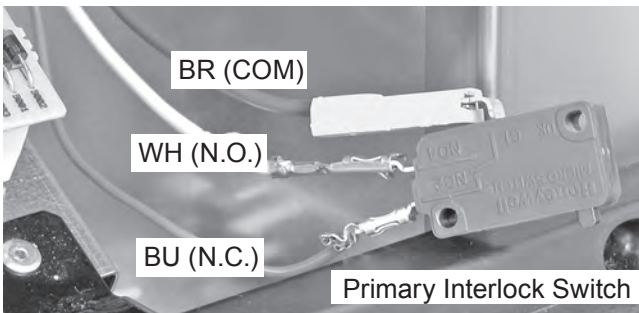

- c) *Monitor (rear):* Disconnect the red (COM) and blue (N.C.) wires from the switch terminals.

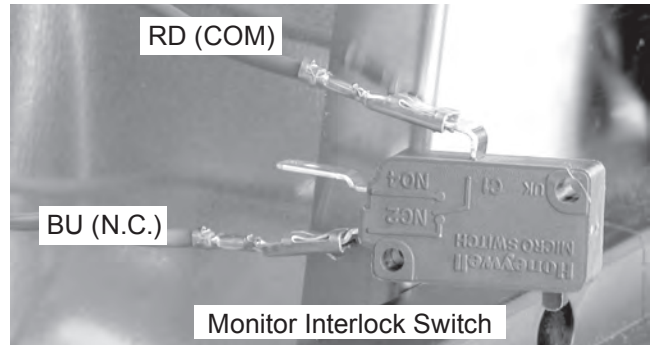

7. **To remove the cavity light:**

- a) Disconnect the two pink cavity light LOAD wires from the microwave light transformer terminals.

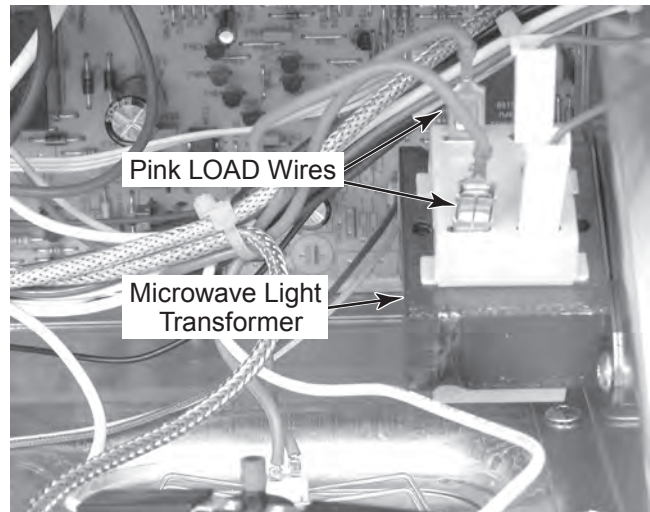

- b) Squeeze the light wire clips, remove the ends from the slot in the chassis, and lift the light and remove it from the chassis.

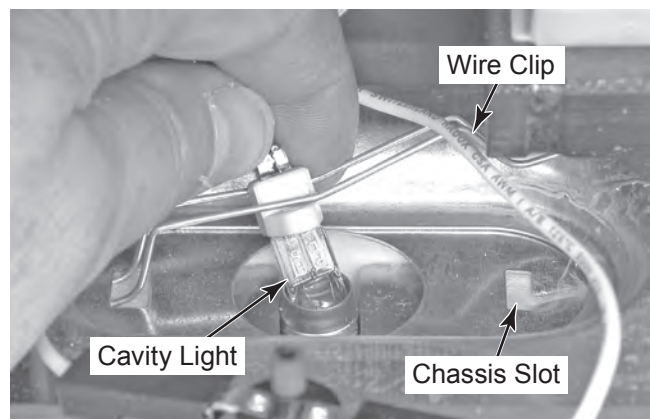

REMOVING THE MAGNETRON THERMOSTAT AND THE MAGNETRON

⚠ WARNING



Electrical Shock Hazard
Disconnect power before servicing.
Replace all parts and panels before operating.
Failure to do so can result in death or electrical shock.

1. Unplug oven or disconnect power.
2. Remove the oven from its mounting location (see “Installation Information” in Section 2) and pull it forward so that you can access the top cover.
3. Remove the four screws from the top cover and remove the cover.

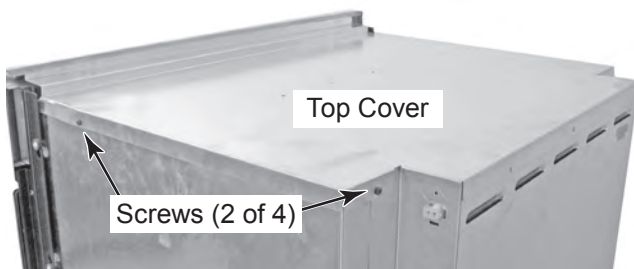

Magnetron & Magnetron Thermostat

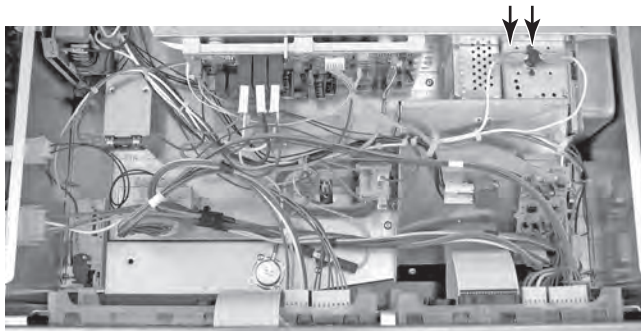

4. To remove the magnetron thermostat:
 - a) Disconnect the two wire connectors from the thermostat terminals.
 - b) Remove the two screws from the thermostat and remove the thermostat.

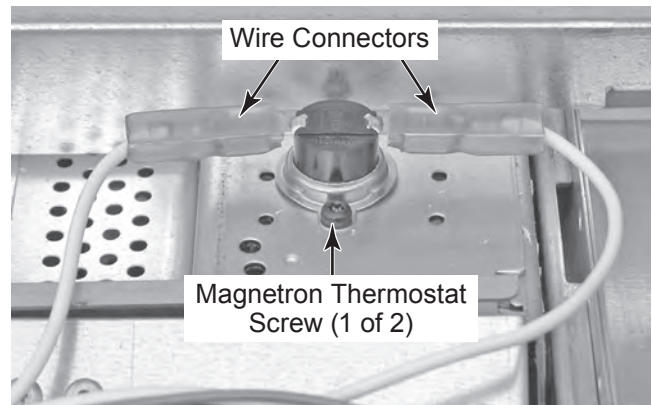

5. To remove the magnetron:
 - a) Remove the magnetron thermostat (see step 4).
 - b) Remove the eight screws from the inner cover and remove the cover.

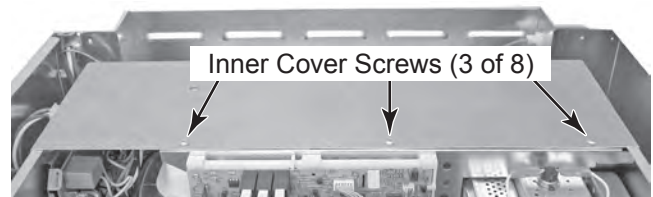

- c) Remove the right screw from the microwave appliance manager board bracket.

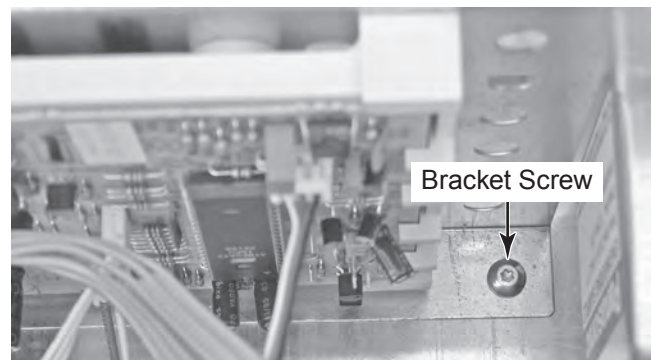

Continued on the next page.

- d) Remove the eight screws from the top right side cover and remove the cover.



- e) Remove the nine screws from the right microwave side cover and remove the cover.

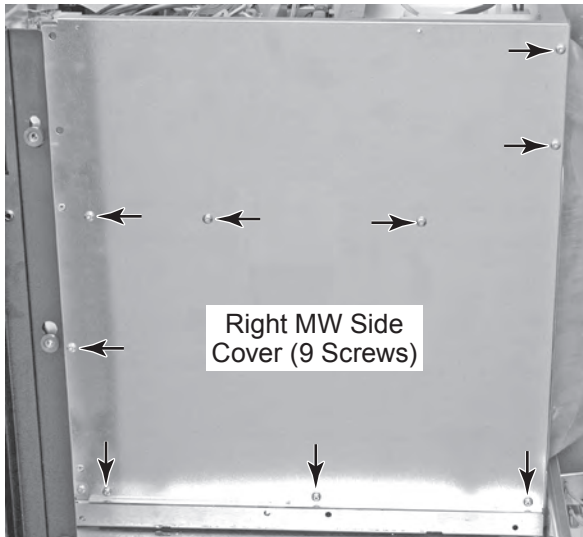

- f) **IMPORTANT:** Touch a screwdriver shaft to the two filament connectors and chassis ground.
- g) Disconnect the two red filament wires from the magnetron terminals.
- h) Remove the four screws from the magnetron, move the end of the microwave relay board bracket out of the way, and remove the magnetron.

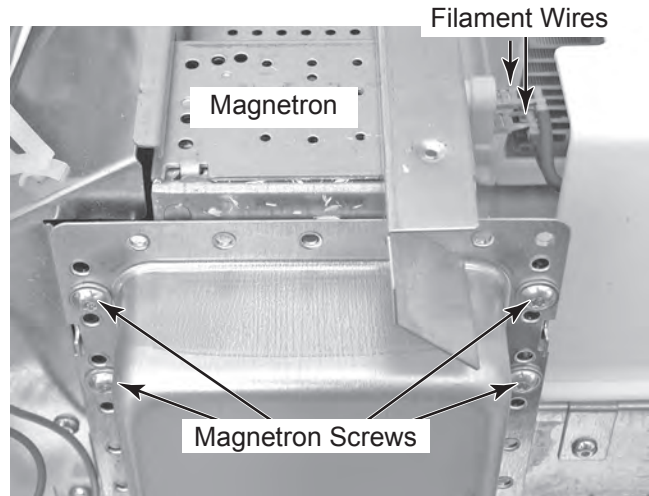

REMOVING THE MAIN L1 FILTER, MAIN L2 FILTER, AND GRILL THERMOSTAT

⚠ WARNING



Electrical Shock Hazard
Disconnect power before servicing.
Replace all parts and panels before operating.
Failure to do so can result in death or electrical shock.

1. Unplug oven or disconnect power.
2. Remove the oven from its mounting location (see “Installation Information” in Section 2) and pull it forward so that you can access the top cover.
3. Remove the four screws from the top cover and remove the cover.



4. Remove the eight screws from the inner cover and remove the cover.

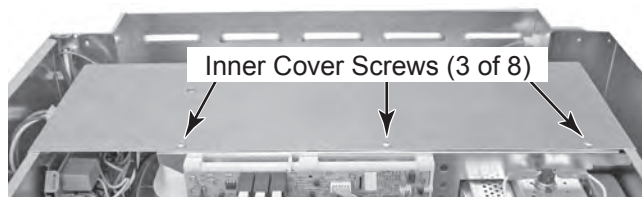

Main L2 Filter Grill Thermostat Main L1 Filter

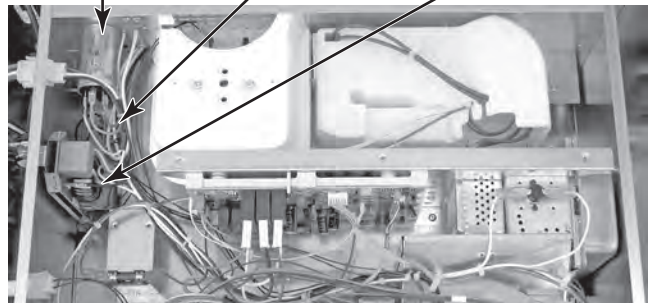

5. To remove the main L1 filter:
 - a) **IMPORTANT:** Discharge the main L2 filter by touching the leads of a 20,000 ohm resistor to the terminals and chassis ground.
 - b) Remove the filter bracket screw, unhook the top and bottom bracket tabs, and remove the bracket from the left side panel.

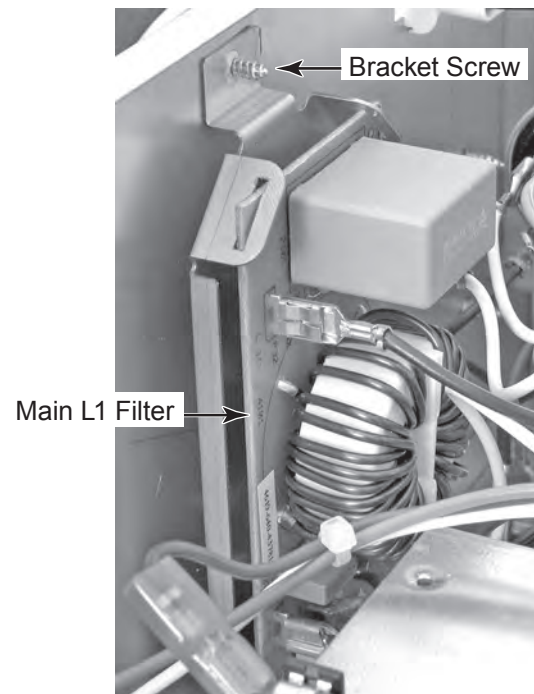

Continued on the next page.

- c) Disconnect the wires from the main L1 filter board as follows:

White at P31 (to 3-pin plug)
 Black at P32
 Brown at P33
 White at P34

- d) Remove the mounting screw and remove the board from the bracket.

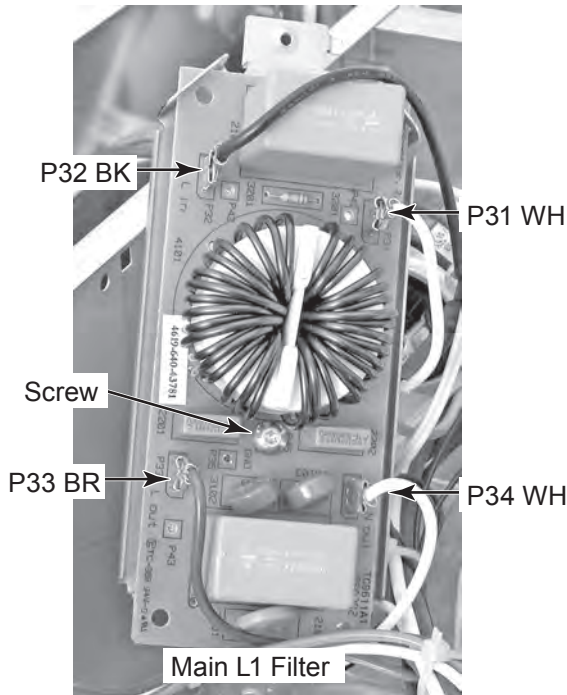

- c) Disconnect the wires from the main L2 filter terminals.

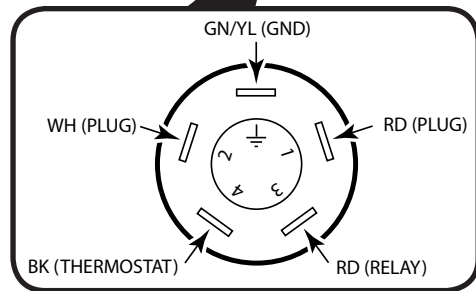
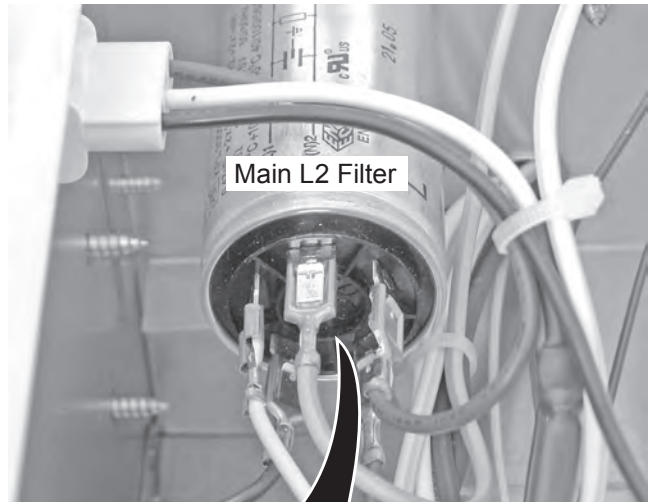

6. **To remove the main L2 filter:**

- a) **IMPORTANT:** Discharge the main L2 filter by touching the leads of a 20,000 ohm resistor to the terminals and chassis ground.
- b) Remove the nut and washer from the main L2 filter stud and remove the filter.

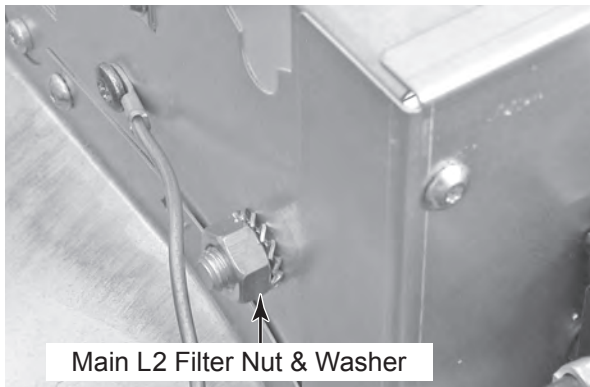

7. **To remove the grill thermostat:**

- a) **IMPORTANT:** Discharge the main L2 filter by touching the leads of a 20,000 ohm resistor to the terminals and chassis ground.
- b) Remove the main L2 filter and move it out of the way of the thermostat (see step 6 for the procedure).
- c) Disconnect the wires from the thermostat terminals.
- d) Remove the two screws from the thermostat and remove the thermostat.

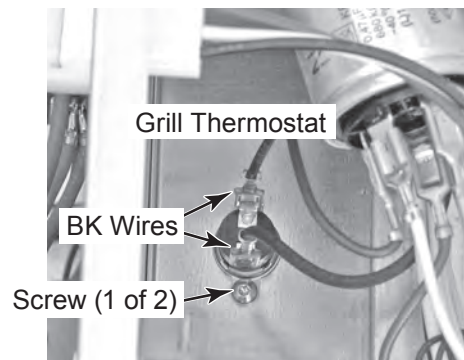

REMOVING THE MAGNETRON FAN MOTOR & THE INVERTER

⚠ WARNING



Electrical Shock Hazard
Disconnect power before servicing.
Replace all parts and panels before operating.
Failure to do so can result in death or electrical shock.

1. Unplug oven or disconnect power.
2. Remove the oven from its mounting location (see “Installation Information” in Section 2) and pull it forward so that you can access the top cover.
3. Remove the four screws from the top cover and remove the cover.

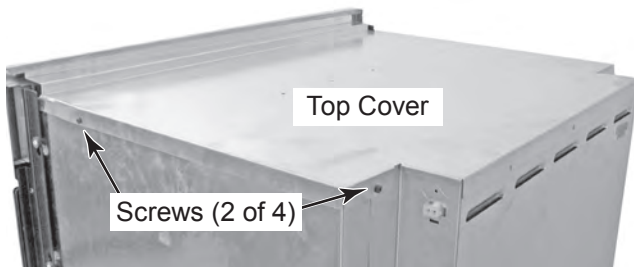

4. Remove the eight screws from the inner cover and remove the cover.

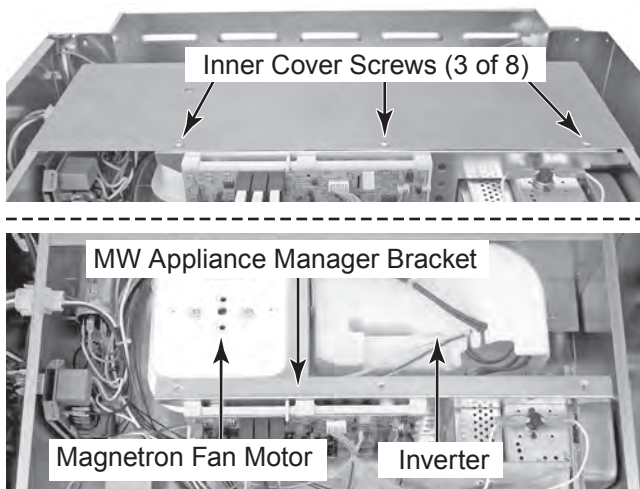

5. Remove the ten screws from the upper rear cover of the oven and remove the cover.

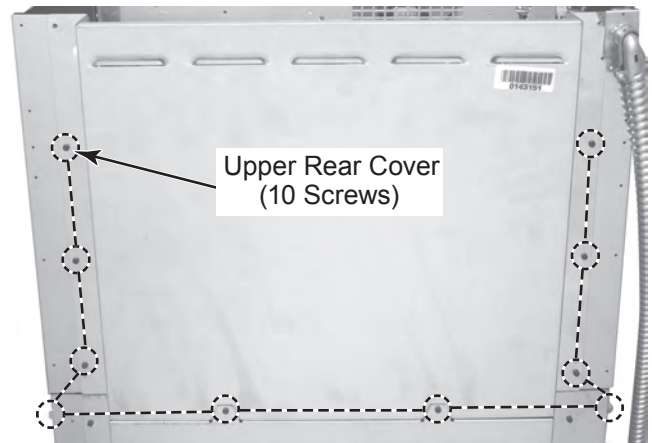

6. **To remove the magnetron fan motor:**
 - a) Remove the left screw from the appliance manager board bracket.

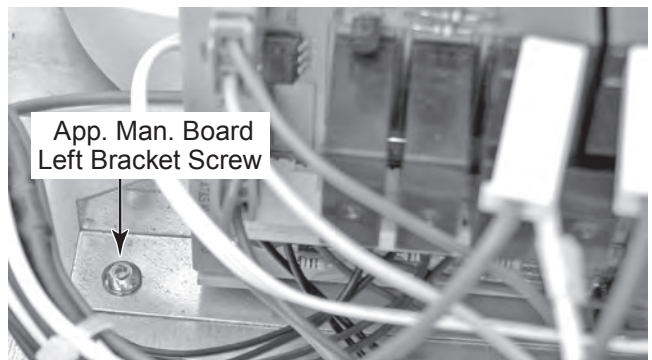

- b) Remove the magnetron fan motor housing screw from the rear of the chassis.

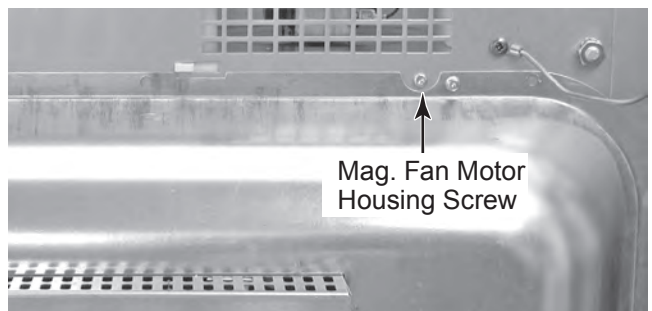

Continued on the next page.

- c) Remove the magnetron fan motor housing assembly and set it on top of the oven.
- d) Disconnect the two black wires from the magnetron fan motor terminals.

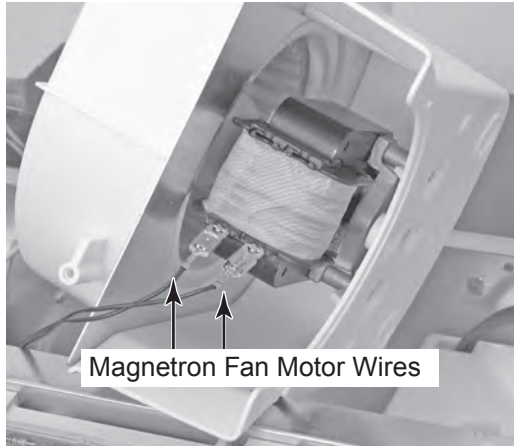

- e) Remove the three screws from the magnetron fan motor housing and separate the sections.

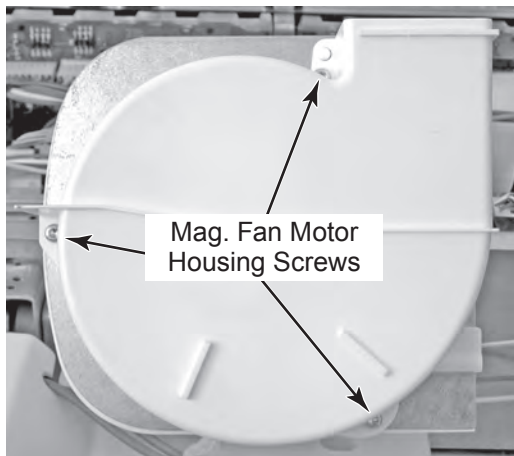

- f) Remove the magnetron fan motor screws from the housing and remove the motor from the housing.

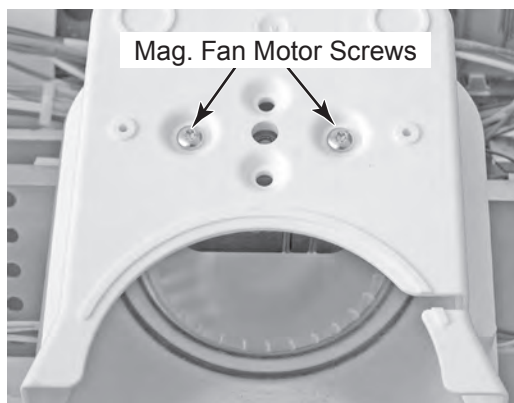

- g) Pull the blower off the magnetron fan motor shaft.

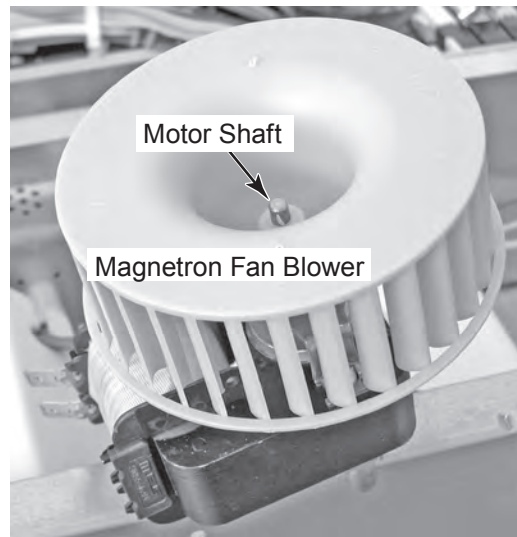

7. To remove the inverter:

- a) Remove the two top screws from the outer convection cover at the rear of the oven.



- b) Remove the two inverter housing screws from the rear of the oven.

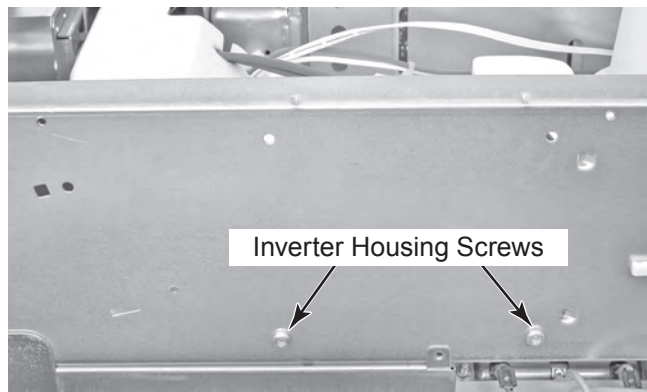

- c) **IMPORTANT:** Touch a screwdriver shaft to the two filament connectors and chassis ground.
- d) Disconnect the two filament wires from the magnetron terminals.
- e) Remove the screw from the green/yellow ground wire.

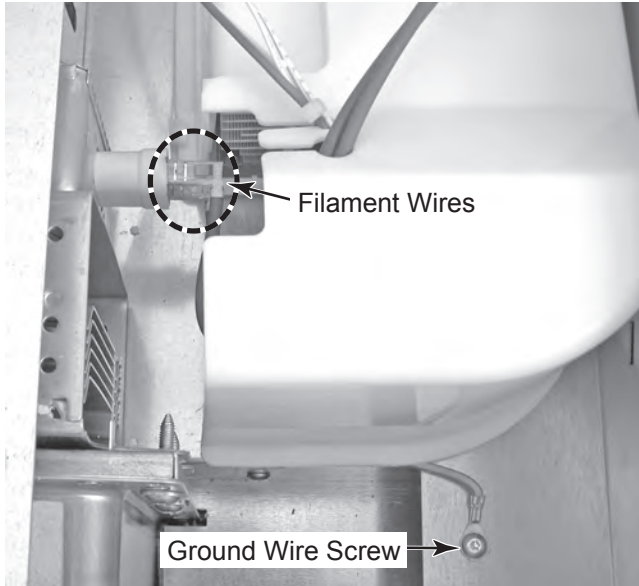

- f) Lift the inverter housing and set it on top of the oven.
- g) Remove the wires from the inverter housing.
- h) Unclip the four housing tabs and lift the top housing off the bottom half.

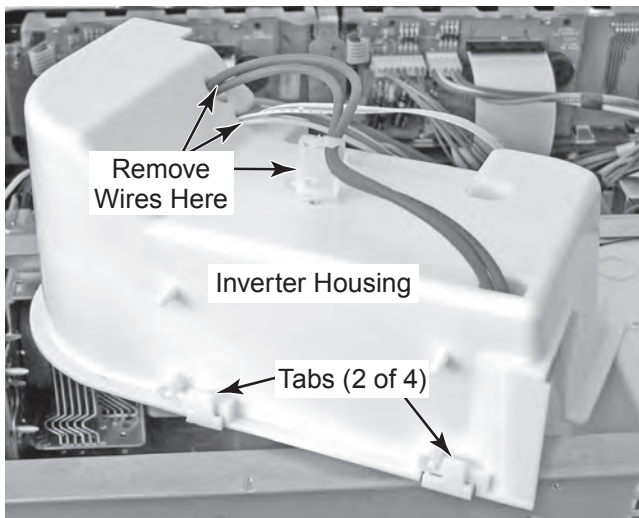

- i) Disconnect the wires from the inverter as follows:
 2 red wires from CN703
 Screw at green/yellow wire E701
 3-wire connector at CN701
 Blue and white wires at CN702

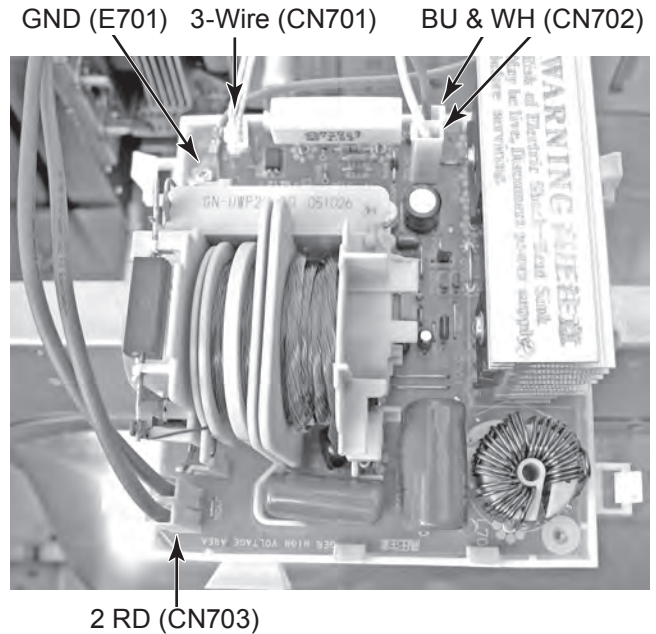

- j) Unhook the two locking tabs and remove the inverter from the lower half of the housing.

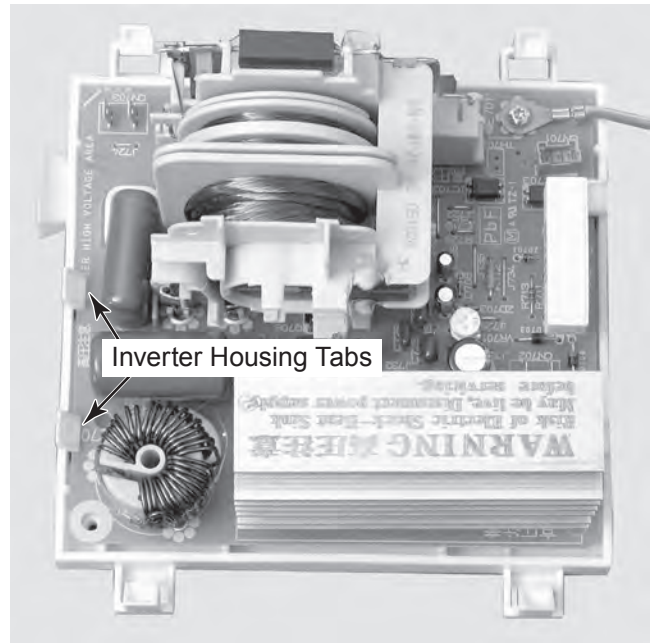

REMOVING THE CONVECTION THERMISTOR AND GRILL ELEMENT

⚠ WARNING



Electrical Shock Hazard

Disconnect power before servicing.

Replace all parts and panels before operating.

Failure to do so can result in death or electrical shock.

1. Unplug oven or disconnect power.
2. Remove the oven from its mounting location (see “Installation Information” in Section 2) and pull it forward so that you can access the top cover.
3. Remove the four screws from the top cover and remove the cover.

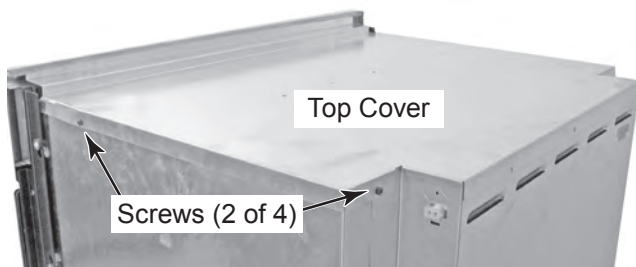

4. Remove the ten screws from the upper rear cover of the oven and remove the cover.

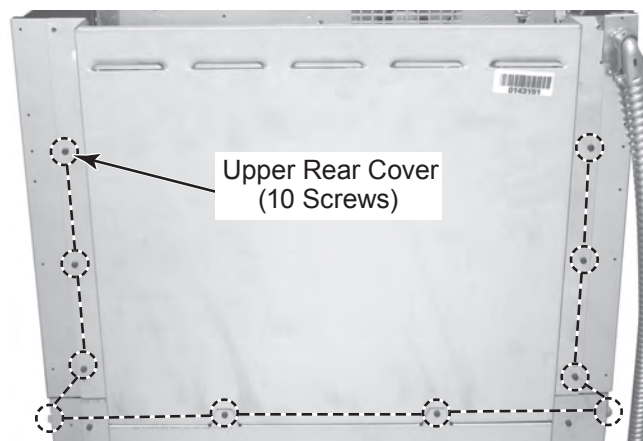

5. Remove the seven screws from the outer convection cover and remove the cover.

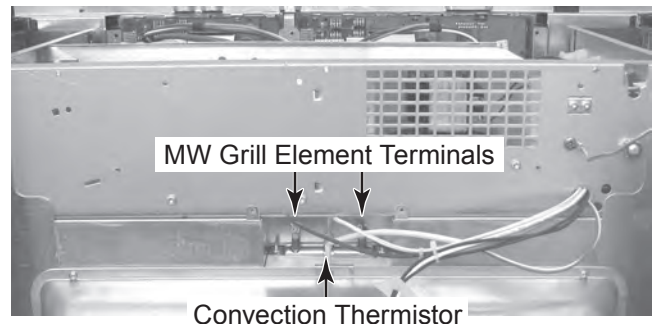
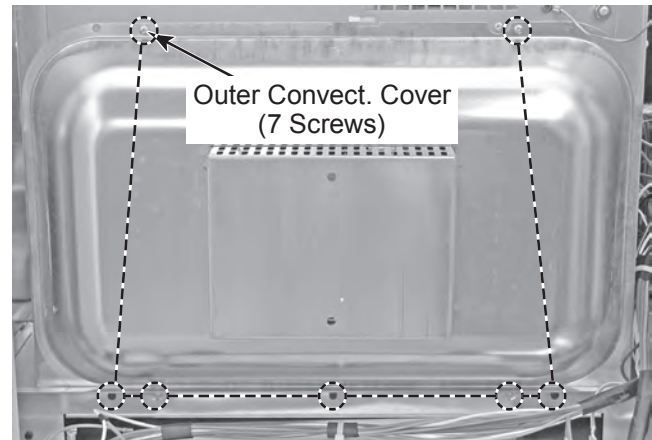

6. **To remove the convection thermistor:**
 - a) Remove the convection thermistor, insulation, and insulation cover from the thermistor.
 - b) Remove the screw from the convection thermistor clip and remove the clip and thermistor.

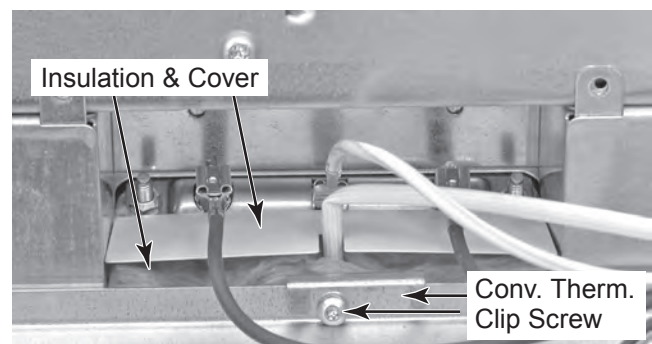

- c) Disconnect the convection thermistor connector from appliance manager connector P6 and remove the thermistor.

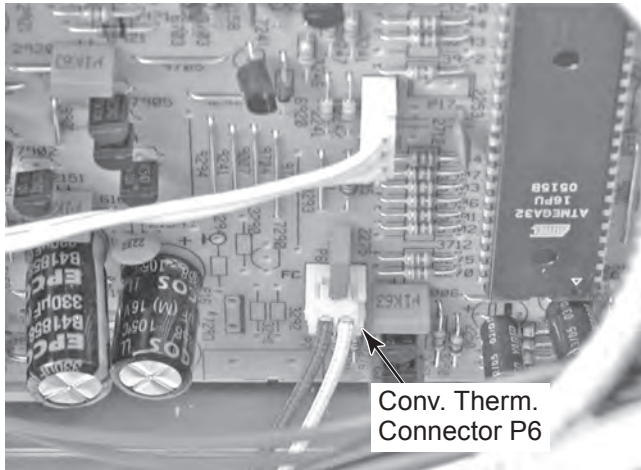

REASSEMBLY NOTE: Install the convection thermistor and clip first, then place the insulation and insulation cover over the thermistor.

7. To remove the grill element:

- a) From the rear of the oven, disconnect the three wires from the grill element terminals.
- b) Remove the two nuts from the grill element studs.

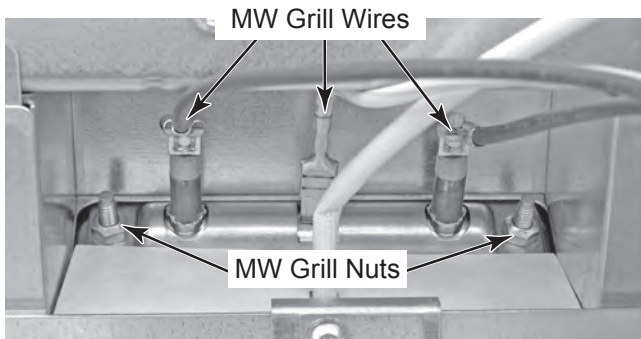

- c) Open the microwave oven door.
- d) Twist the front grill element support 90° in either direction and remove it from the cavity slot.

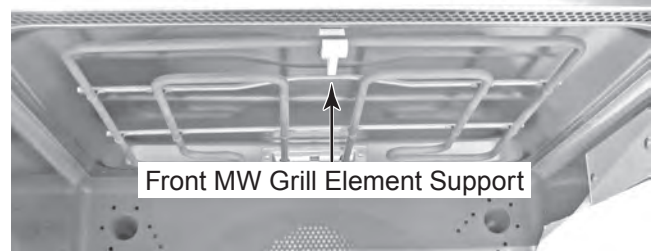

- e) Lower the front of the grill element, pull the element terminals out the back holes of the cavity, and remove the element.

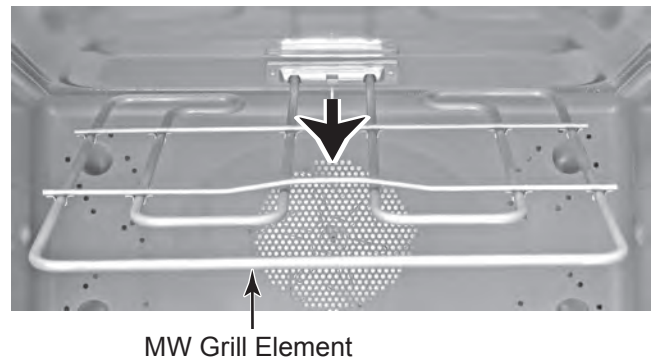

REMOVING THE LOWER OVEN APPLIANCE MANAGER

⚠ WARNING



Electrical Shock Hazard

Disconnect power before servicing.

Replace all parts and panels before operating.

Failure to do so can result in death or electrical shock.

1. Unplug oven or disconnect power.
2. Remove the oven from its mounting location (see “Installation Information” in Section 2) and pull it forward so that you can access the top cover.
3. Remove the four screws from the top cover and remove the cover.

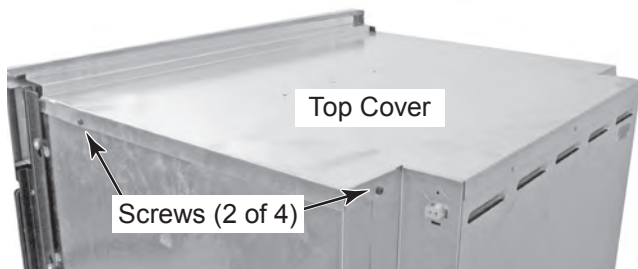

4. Remove the eight screws from the inner cover and remove the cover.

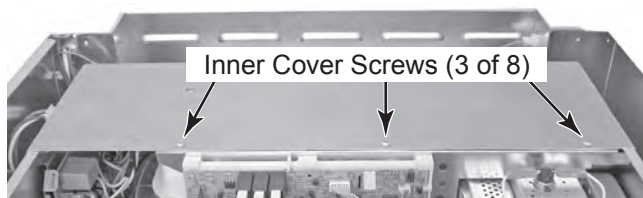

5. Unhook and remove the AC wiring conduit connector from the back of the upper left side cover (see the top right photo).
6. Remove the eight screws from the upper left side cover and remove the cover.

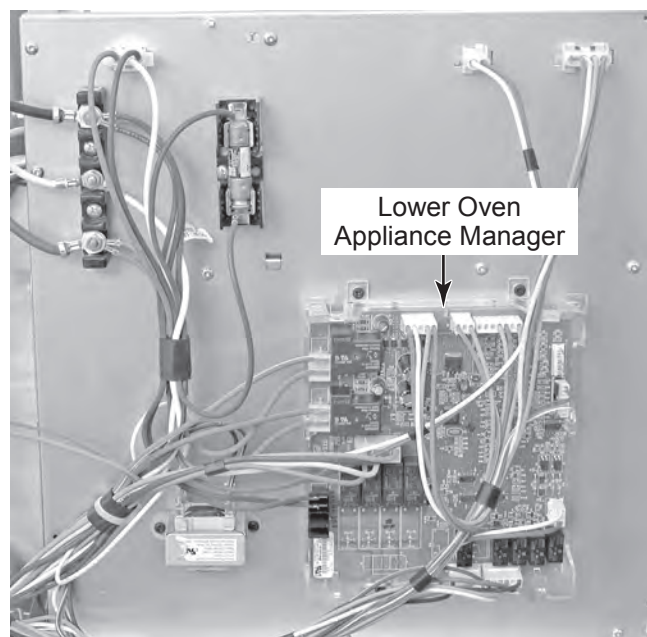
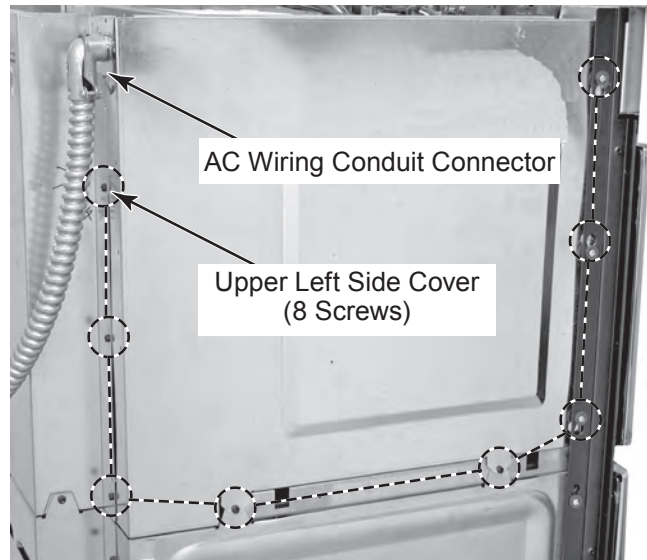

7. Disconnect the wire connectors from the lower oven appliance manager board pins. The wire connector colors are as follows:
 - T1 = PK/WH, PK
 - T2 = 2 PK
 - T3 = OR, RD, YL, BU
 - T4 = 2 BK
 - P9 = GY, BK
 - P8 = BK, OR, GY, YL, BK/WH
 - P7 = VI, WH
 - P2 = 2 VI, OR, WH
 - P1 = PK, BR, TN
 - P5 = GN, PK/WH
 - P6 = BR, OR, YL, BU
8. Remove the four lower oven appliance manager housing screws and remove the housing assembly.

9. Unclip the six tabs from the lower oven appliance manager and remove it from the housing.

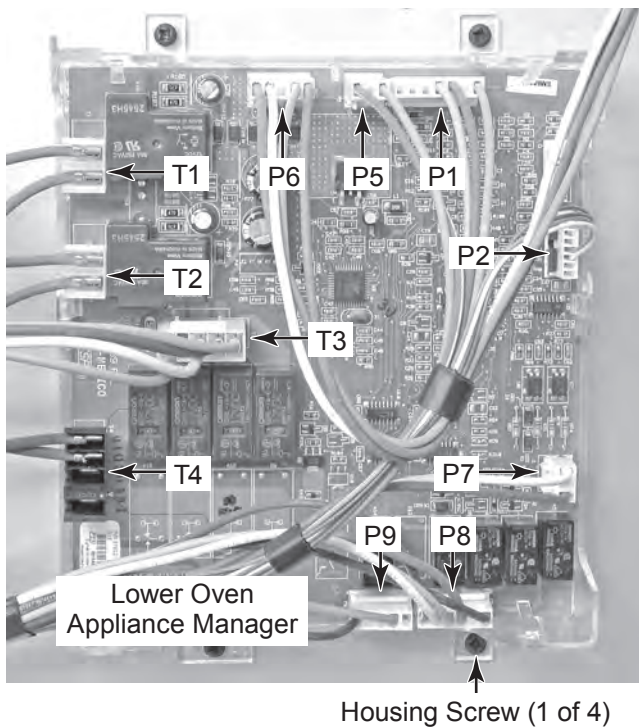
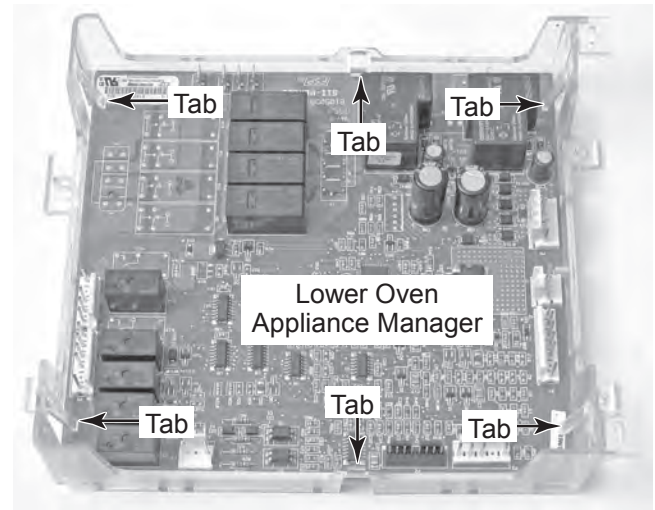

REMOVING THE LINE FUSE HOLDER & LOWER OVEN LIGHT TRANSFORMER

⚠ WARNING



Electrical Shock Hazard

**Disconnect power before servicing.
Replace all parts and panels before operating.**

Failure to do so can result in death or electrical shock.

1. Unplug oven or disconnect power.
2. Remove the oven from its mounting location (see "Installation Information" in Section 2) and pull it forward so that you can access the top cover.
3. Remove the upper left side cover from the oven (see page 4-18 for the procedure).

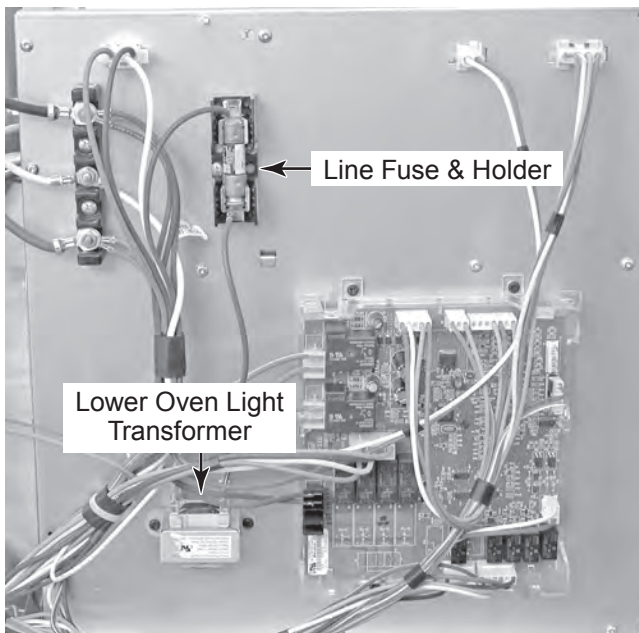

4. **To remove the line fuse and holder:**
 - a) Pull the fuse out of the holder clips.
 - b) Disconnect the two black wires from the fuse holder terminals.
 - c) Remove the two screws from the fuse holder and remove it.

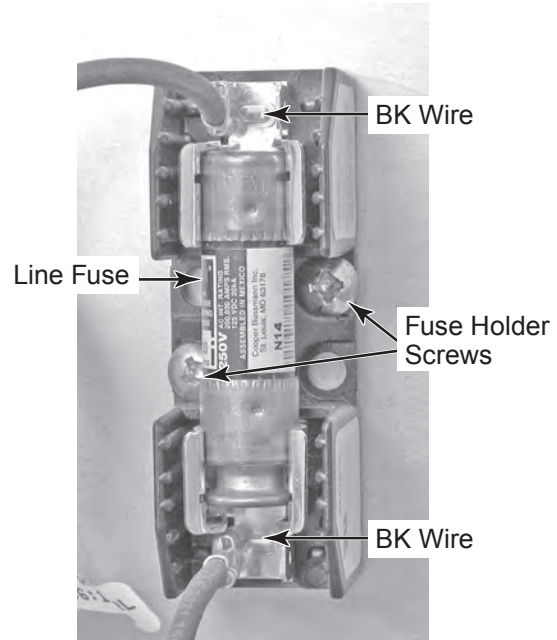

5. **To remove the lower oven light transformer:**
 - a) Disconnect the four wire connectors from the transformer terminals.
 - b) Remove the two screws from the transformer and remove it.

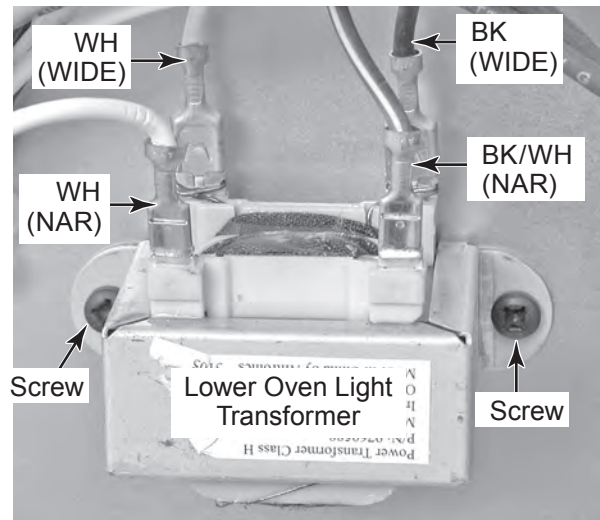

REMOVING THE AC TERMINAL BLOCK

⚠ WARNING



Electrical Shock Hazard
Disconnect power before servicing.
Replace all parts and panels before operating.
Failure to do so can result in death or electrical shock.

1. Unplug oven or disconnect power.
2. Remove the oven from its mounting location (see “Installation Information” in Section 2) and pull it forward so that you can access the top cover.
3. Remove the upper left side cover from the oven (see page 4-18 for the procedure).

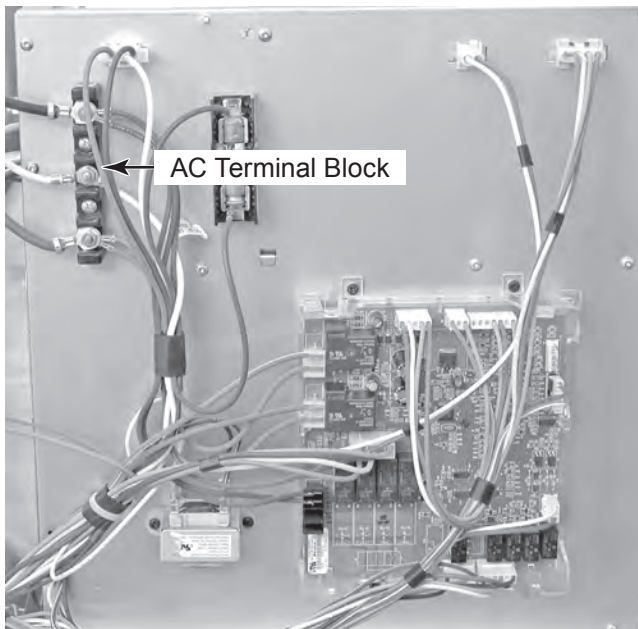

4. Remove the nuts from the black, white, and red wires and remove the wires from the terminal block studs.
5. Remove the two mounting screws from the terminal block and remove it from the side cover.

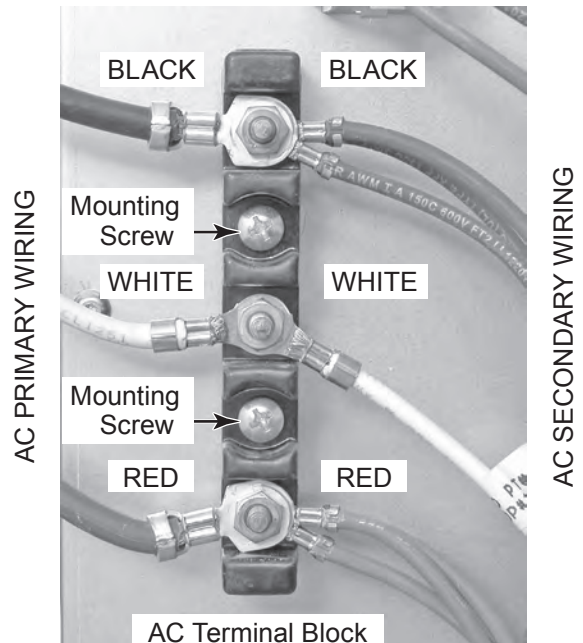

REMOVING THE CONVECTION THERMOSTAT, RING ELEMENT, AND FAN MOTOR

⚠ WARNING



Electrical Shock Hazard

Disconnect power before servicing.

Replace all parts and panels before operating.

Failure to do so can result in death or electrical shock.

1. Unplug oven or disconnect power.
2. Remove the oven from its mounting location (see “Installation Information” in Section 2) and pull it forward so that you can access the top cover.
3. Remove the four screws from the top cover and remove the cover.



4. Remove the ten screws from the upper rear cover of the oven and remove the cover.

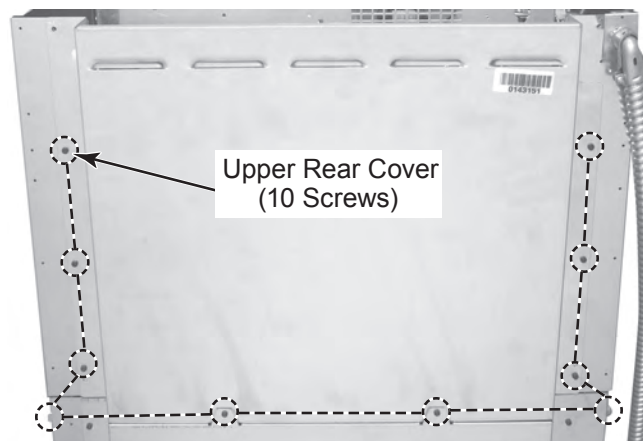

5. Remove the seven screws from the outer convection cover and remove the cover.

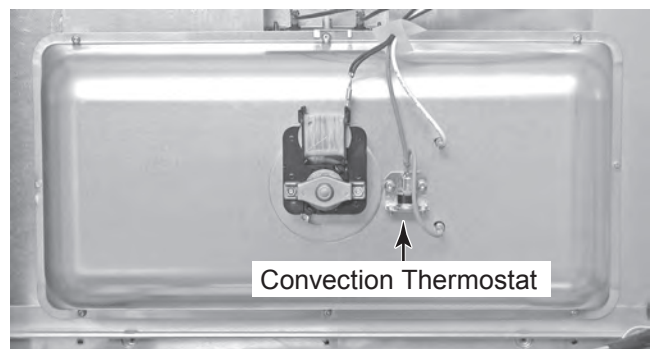
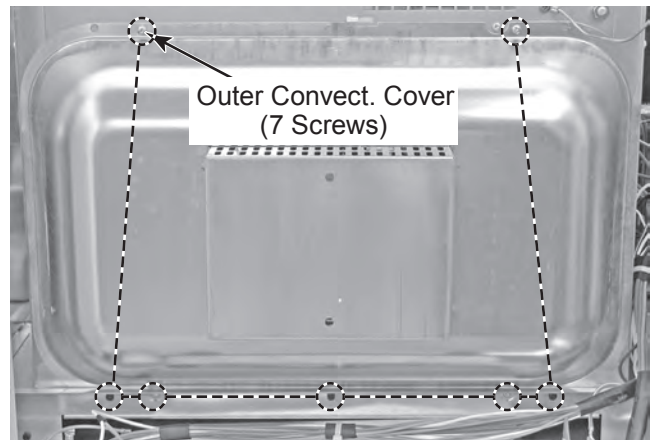

6. **To remove the convection thermostat:**
 - a) Disconnect the two blue wires from the terminals.
 - b) Remove the two screws from the thermostat.

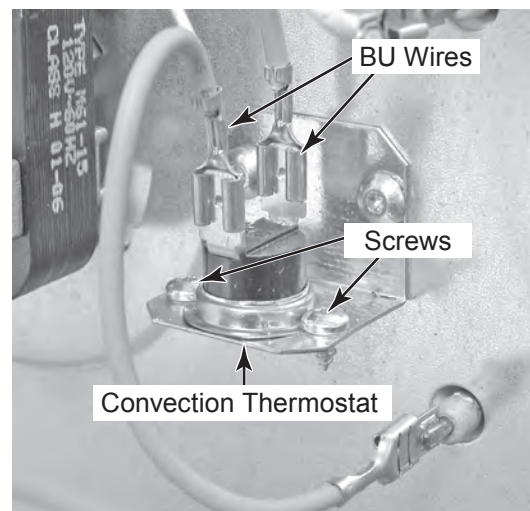

7. **To remove the convection ring element:**

- a) Disconnect the two wires from the ring element terminals.
- b) Remove the six screws, (including the cavity thermostat clip), from the inner convection cover, remove the cover, and turn it over.

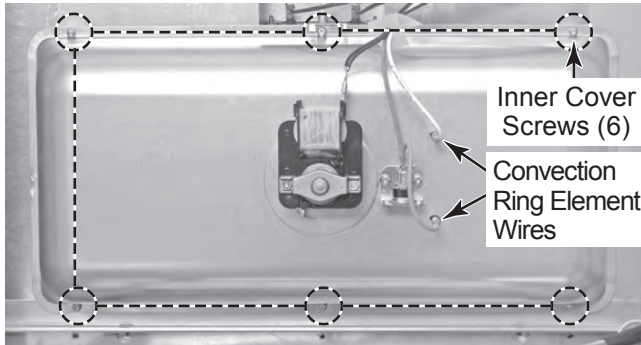

- c) Remove the two screws from the ring element bracket and the screw from the clip, and remove the element from the cover.

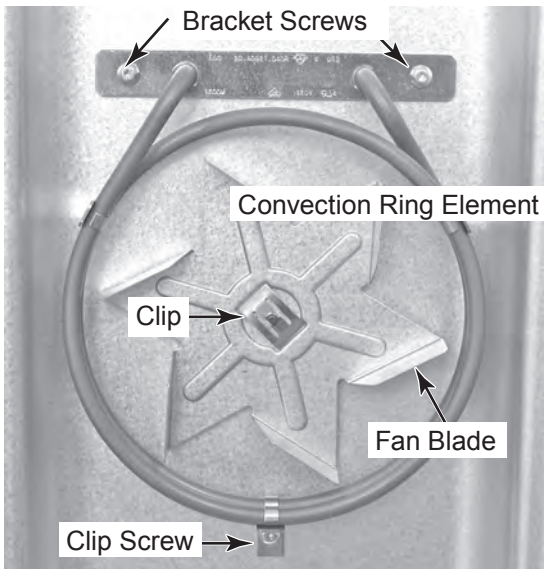

8. **To remove the convection fan motor:**

- a) Disconnect the two wires from the fan motor terminals.
- b) Remove the six screws, (including the cavity thermostat clip), from the inner convection cover, remove the cover, and turn it over.

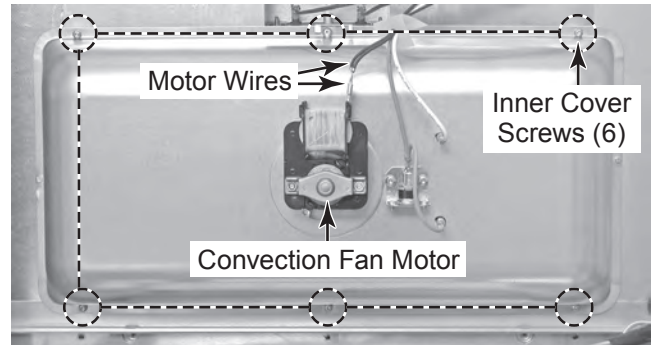

- c) Pry out on the clip center tabs (see the lower left photo), and remove the clip, the fan blade, and flat washer (behind blade) from the fan motor shaft.
- d) Turn the convection fan motor so that the tabs are in the large slots of the cover and remove the motor from the cover.

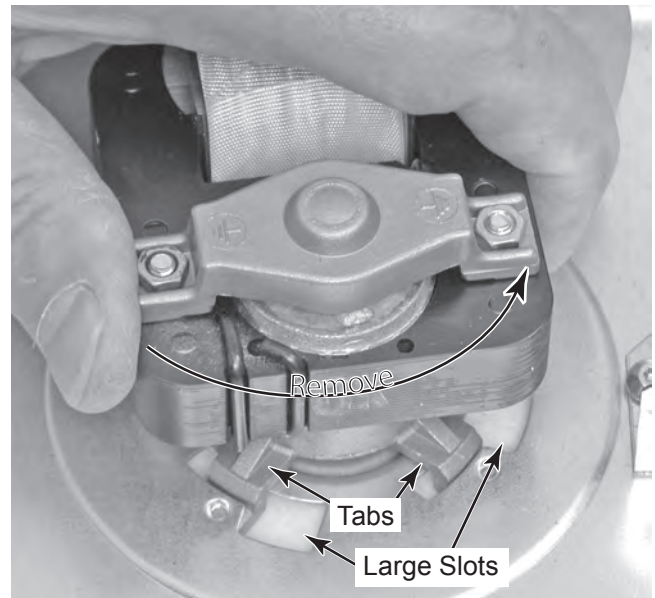

REMOVING THE TURNTABLE MOTOR

⚠ WARNING



Electrical Shock Hazard

Disconnect power before servicing.

Replace all parts and panels before operating.

Failure to do so can result in death or electrical shock.

1. Unplug oven or disconnect power.
2. Remove the oven from its mounting location (see “Installation Information” in Section 2) and pull it forward so that you can access the top cover.
3. Remove the four screws from the top cover and remove the cover.

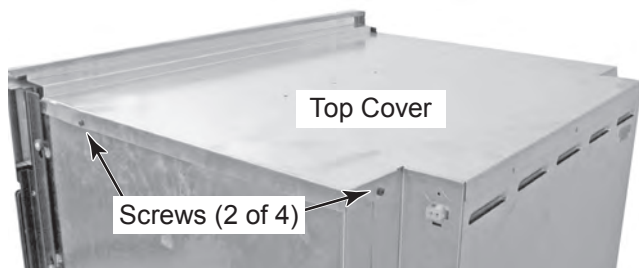

4. Open the microwave oven door, remove the two flat-head screws from the bottom of the control panel frame, and remove the frame.

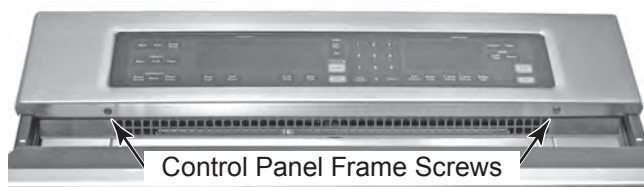

5. Remove the four screws from the front control subpanel, remove the subpanel assembly, and lay it on top of the oven.



6. Remove the six screws from the left and right rails and remove the rails from the oven.

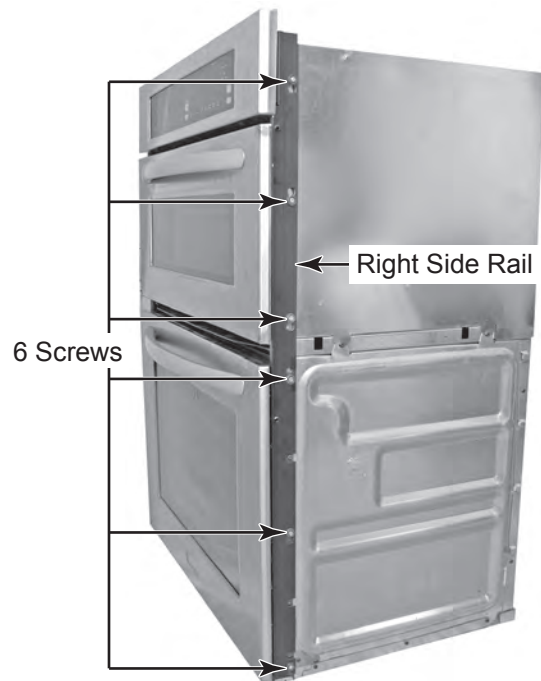

7. Unhook and remove the AC wiring conduit connector from the back of the upper left side cover.
8. Remove the five screws from the upper left side cover and remove the cover.
9. Remove the five screws from the upper right side cover and remove the cover.

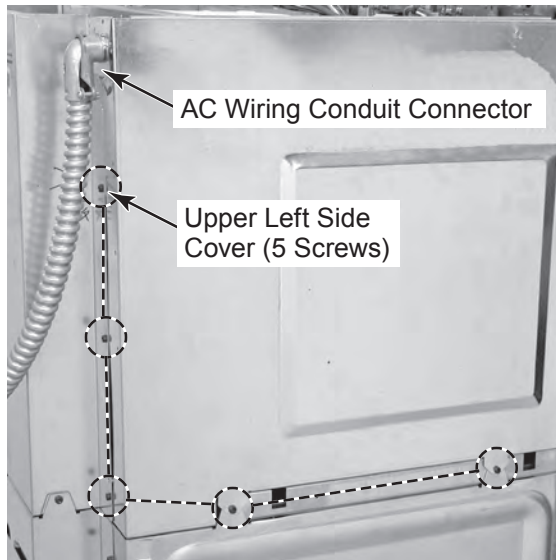

10. Remove the ten screws from the upper rear cover of the oven and remove the cover.

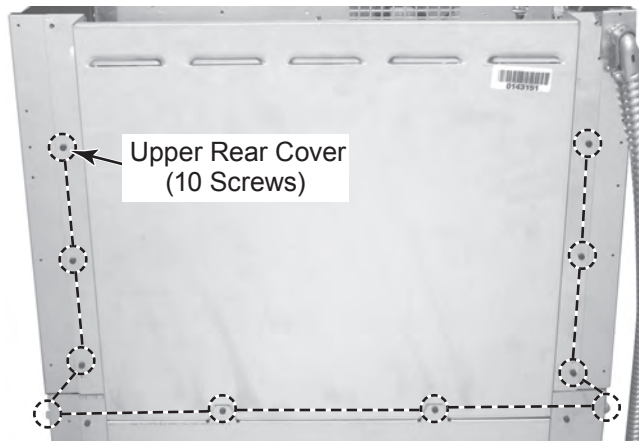

11. Set the control subpanel assembly in its place on the front of the oven and hold it in place so it does not fall.

NOTE: You will need something approximately 12-13" long to prop up the front of the microwave oven in step 12.

12. Lift the front of the microwave oven and securely prop it up so that you can access the turntable motor.
13. Remove the two screws from the motor.

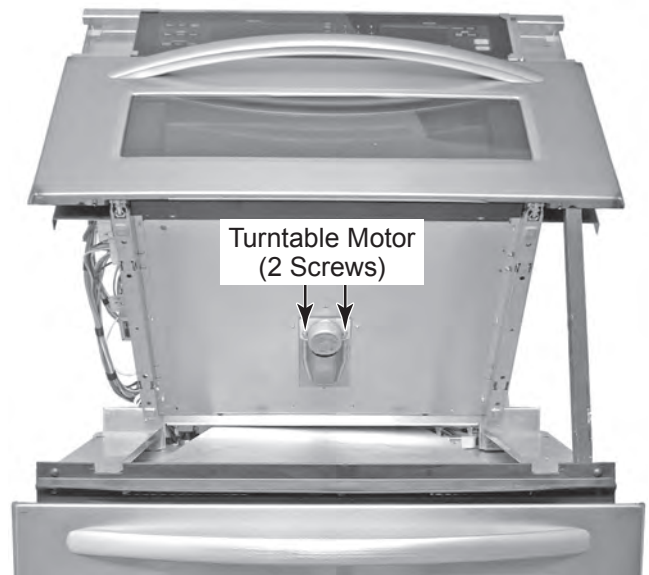

Continued on the next page.

14. Lower the motor as far as possible, pull the turntable coupler off the motor shaft and remove the motor from the oven.
15. Remove the cardboard insulator and the round rubber spacer from the motor.
16. Disconnect the two wire connectors from the motor terminals.

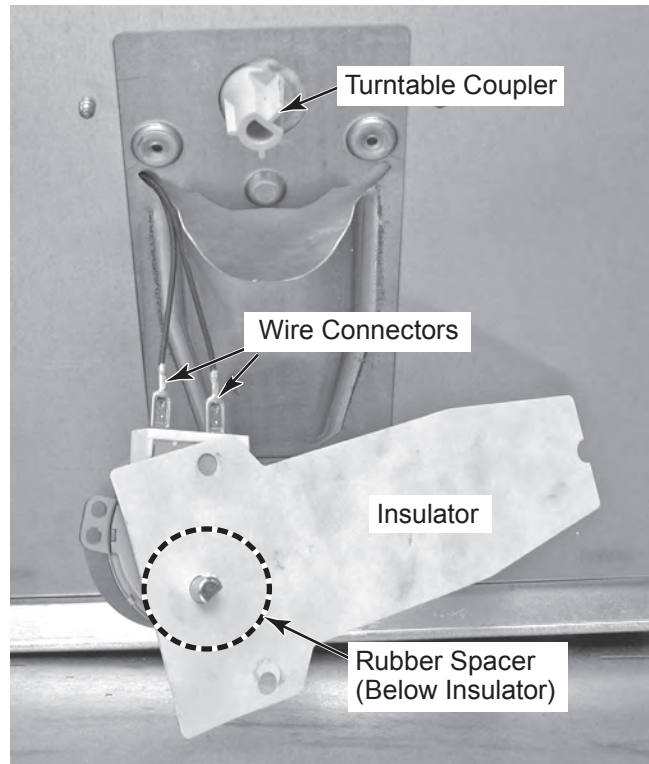

Lower Oven Components

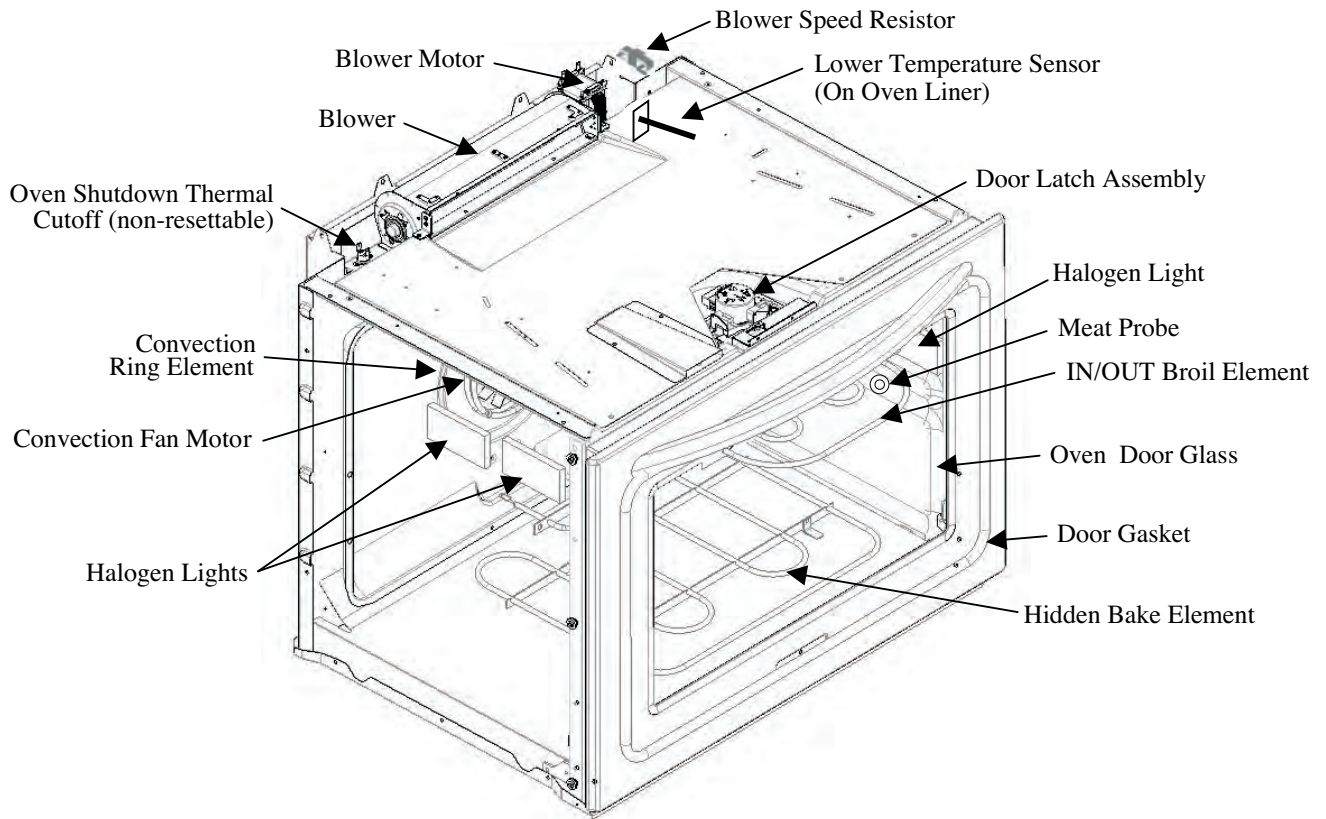

REMOVING THE DOOR LATCH ASSEMBLY

⚠ WARNING



Electrical Shock Hazard

Disconnect power before servicing.

Replace all parts and panels before operating.

Failure to do so can result in death or electrical shock.

1. Unplug oven or disconnect power.
2. Prop the microwave oven up so you can access the door latch assembly (see pages 4-24 & 4-25 for the procedure).
3. Open the lower oven door.
4. Remove the four screws from the lower oven air vent and remove the vent.

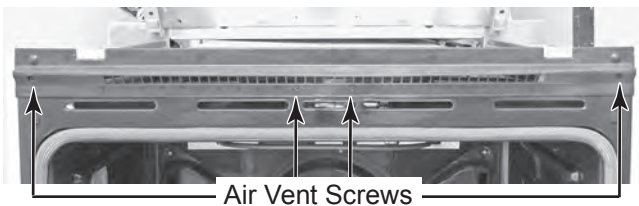

5. Bend and break the two front tabs on the top air duct latch assembly cover.
6. Using a pair of side-cutters, cut the two front joins on the top air duct latch assembly cover, then bend the top and bottom covers up as far as they will go.

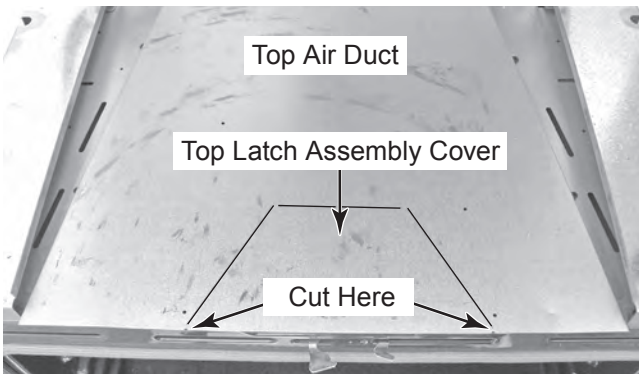

7. Remove the two screws from the door latch assembly, pull the latch assembly back to remove the latches from the cutouts, and then lift and pull it forward so that you can access the wiring.

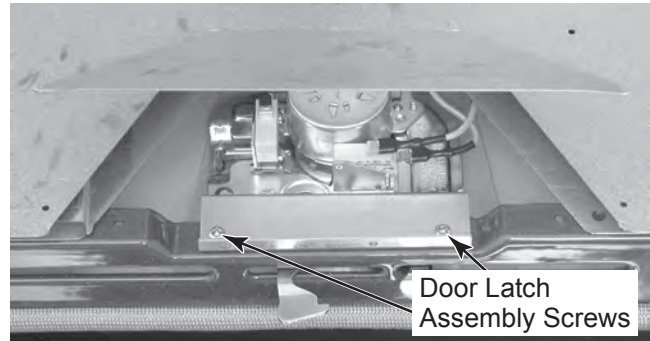

8. Disconnect the wires from the assembly as follows:

Latch motor = yellow & white

Door switch = brown (C) & orange (N.O.)

Latch switch = gray (C) & blue (N.O.)

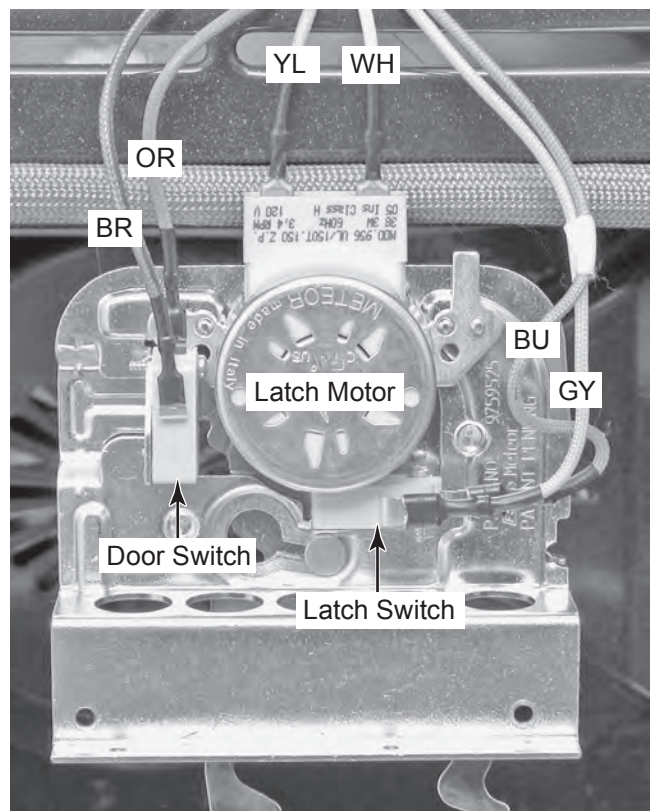

9. To remove the latch motor, remove the two motor screws from the bottom of the assembly.

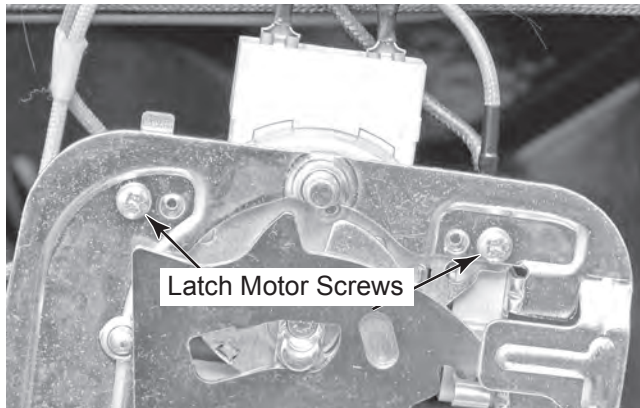

10. To remove the door or latch switch, remove the bracket screw. **NOTE:** You will have to remove the latch motor (in step 9) to access the door or latch switch screws.

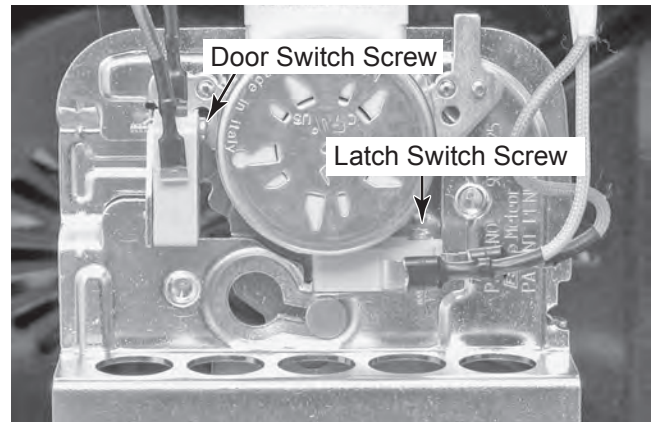

REASSEMBLY NOTE: After you reinstall the door latch assembly in the oven, press the two covers back down into place. Use a piece of shipping tape and tape over the front edge of the top cover to hold it in place and keep it from vibrating during operation.

REMOVING THE BROIL ELEMENT AND THE OVEN TEMPERATURE SENSOR

! WARNING



Electrical Shock Hazard

Disconnect power before servicing.

Replace all parts and panels before operating.

Failure to do so can result in death or electrical shock.

1. Unplug oven or disconnect power.
2. Open the lower oven door.

Broil Element Temperature Sensor

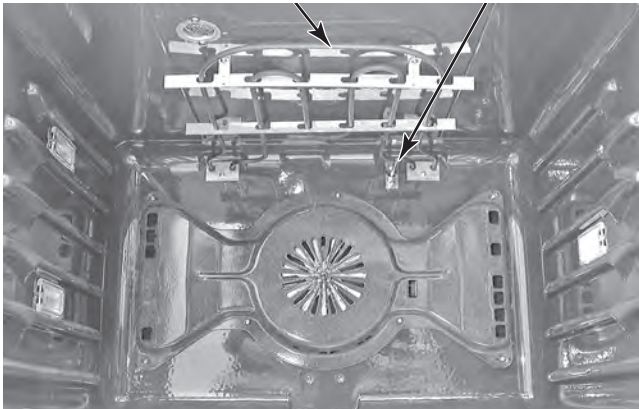

3. **To remove the broil element:**

- a) Remove the four screws from the front and rear brackets (see the top right photo).

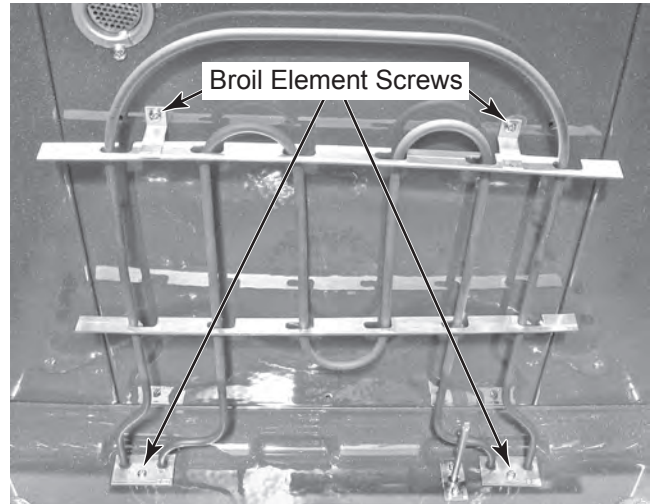

- b) Pull the broil element forward until you can access the wire terminals.
- c) Disconnect the orange and blue wire connectors from the broil element terminals and remove the element.

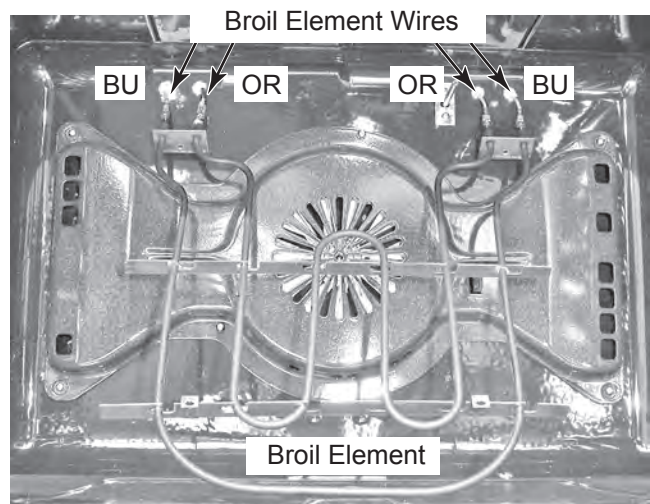

4. To remove the oven temperature sensor:

- a) Remove the screws from the sensor bracket.

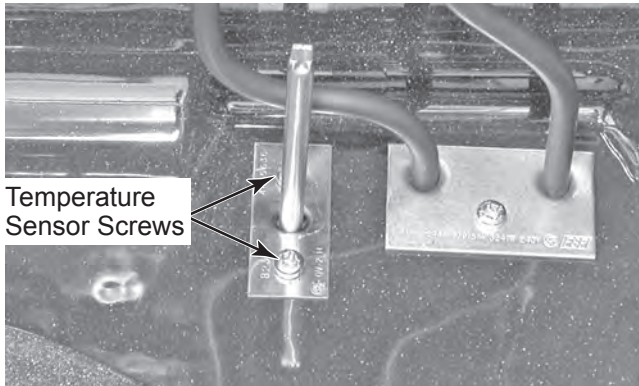

- b) Remove the oven from its mounting location (see "Installation Information" in Section 2) and pull it forward so that you can access the top cover.
- c) Remove the four screws from the top cover and remove the cover.

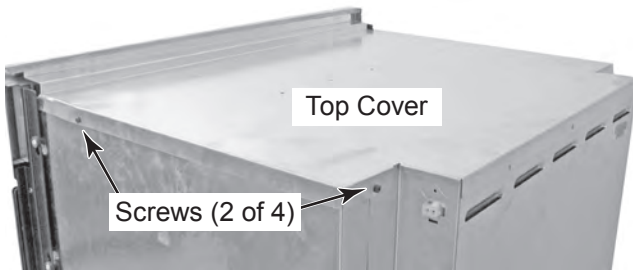

- d) Remove the twelve screws from the lower rear cover and remove the cover.

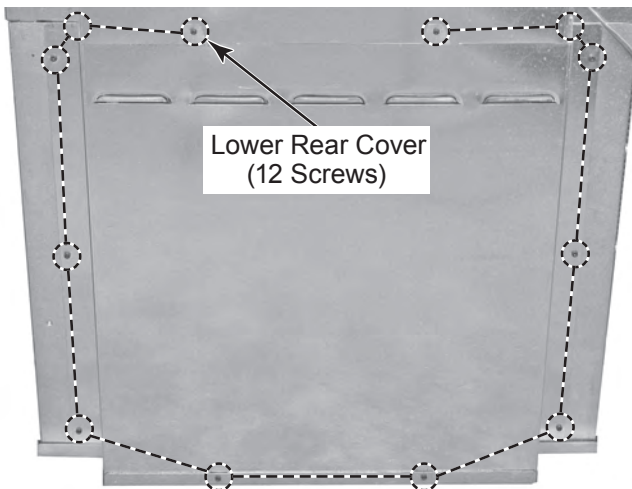

- e) Disconnect the sensor wire connector from the wiring harness.
- f) Push the sensor wire connector through the oven liner hole from the rear of the oven.

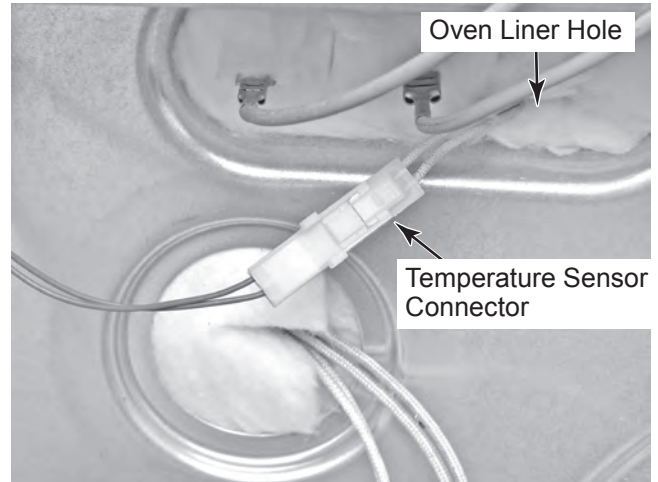

- g) Pull the temperature sensor connector out of the hole and remove the sensor.

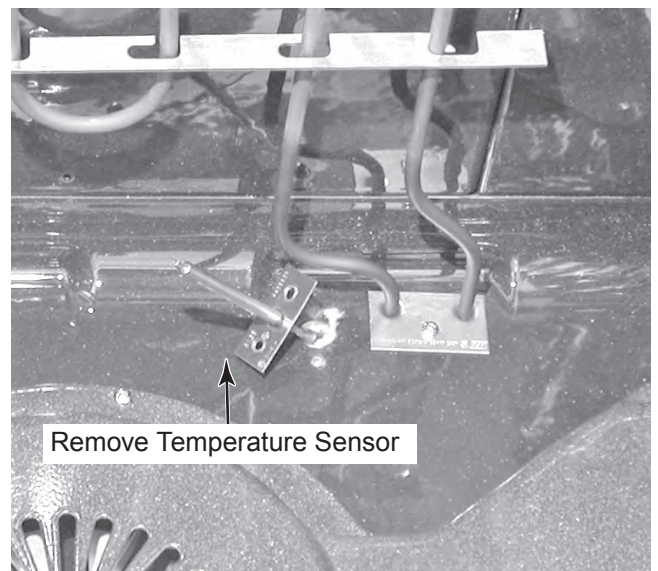

REMOVING THE CONVECTION RING ELEMENT AND THE CONVECTION FAN MOTOR

⚠ WARNING



Electrical Shock Hazard

Disconnect power before servicing.
Replace all parts and panels before operating.

Failure to do so can result in death or electrical shock.

1. Unplug oven or disconnect power.
2. Open the lower oven door.
3. Remove the seven screws from the convection cover and remove the cover.

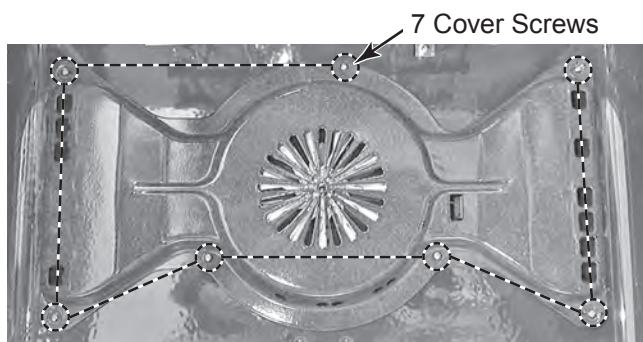
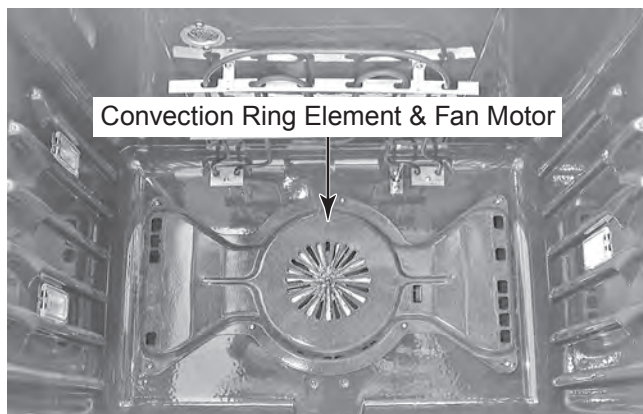

4. To remove the convection ring element:
 - a) Remove the two screws from the element brackets.

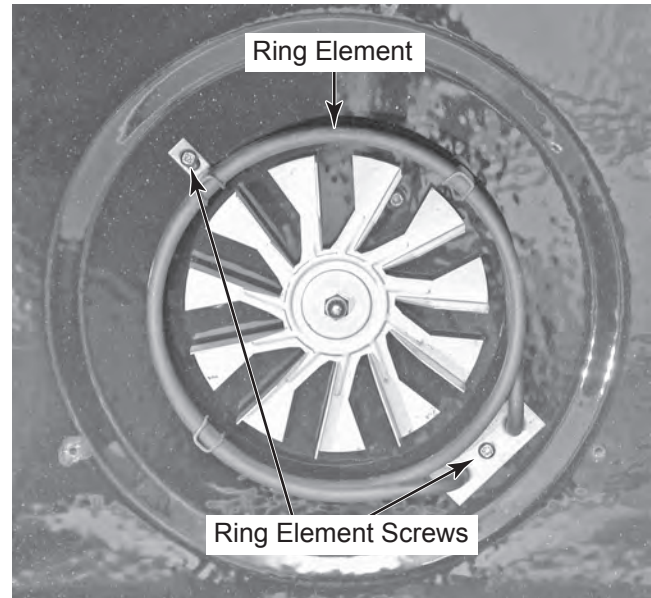

- b) Pull the convection ring element forward far enough to access the two wire connectors.
- c) Disconnect the wire connectors from the convection ring element terminals and remove the element.

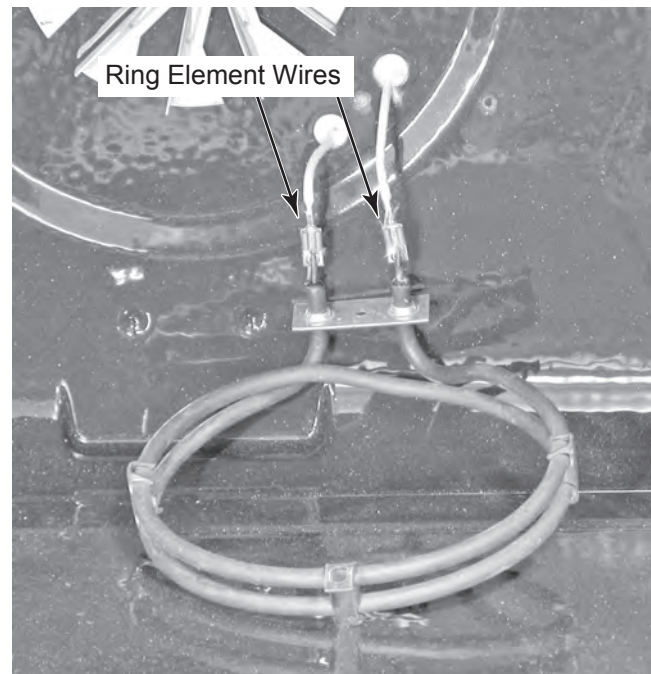

5. To remove the convection fan motor:

- a) Remove the 10mm hex nut from the convection fan blade (left-hand rotation) and remove the blade from the motor shaft.

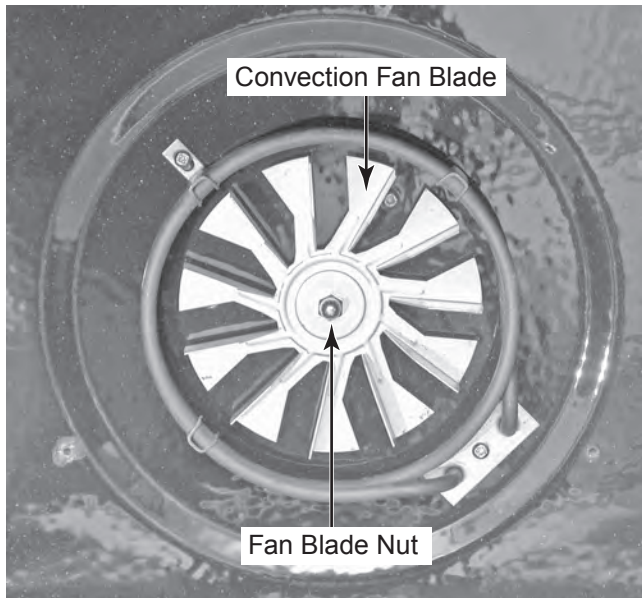

- b) Remove the three front screws from the convection fan motor.

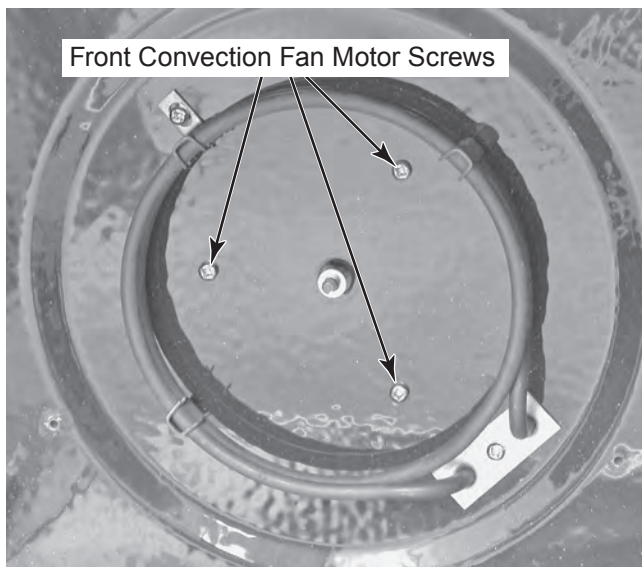

- c) Remove the oven from its mounting location (see "Installation Information" in Section 2) and pull it forward so that you can access the rear covers.

- d) Remove the twelve screws from the lower rear cover and remove the cover.

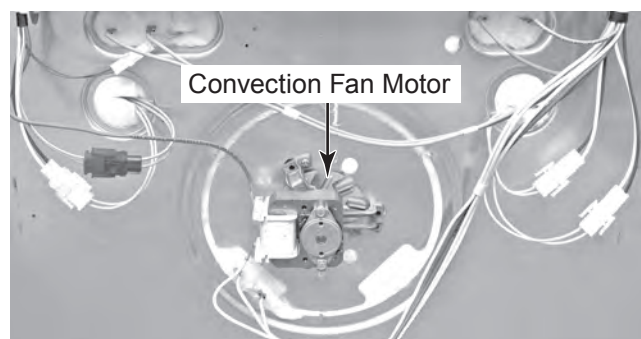
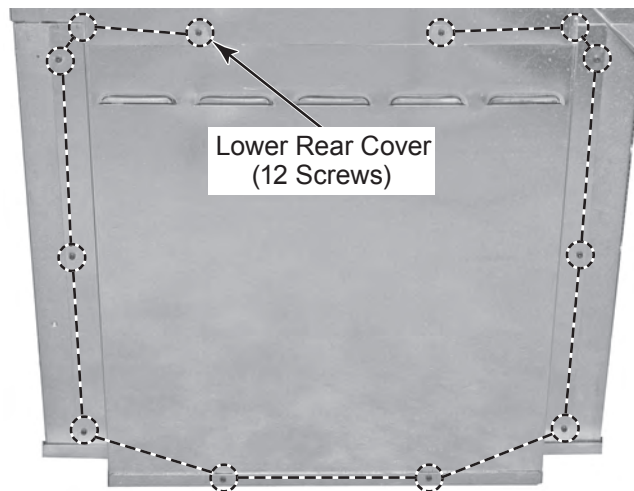

- e) Disconnect the red and yellow wires from the convection fan motor terminals.
- f) Remove the two screws from the fan motor and remove the motor.

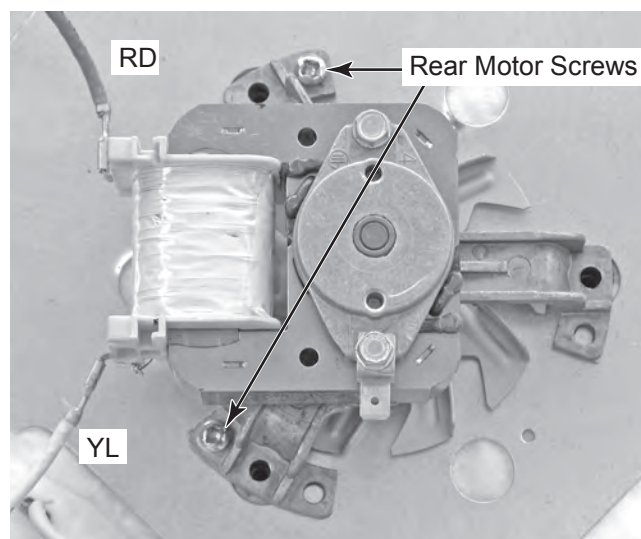

REMOVING A HALOGEN LIGHT ASSEMBLY AND THE MEAT PROBE JACK

⚠ WARNING



Electrical Shock Hazard

**Disconnect power before servicing.
Replace all parts and panels before operating.**

Failure to do so can result in death or electrical shock.

1. Unplug oven or disconnect power.
2. Open the lower oven door.

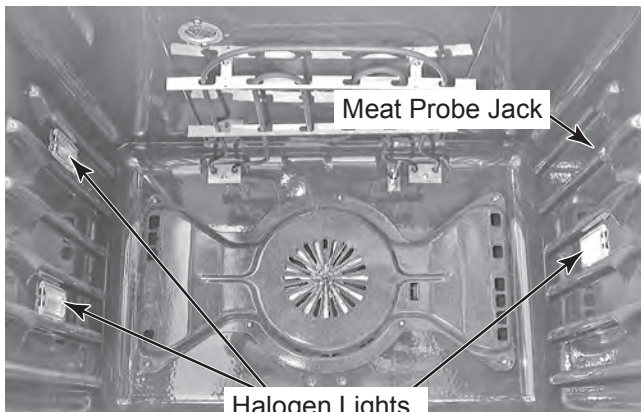

3. To remove a halogen light assembly:

- a) Remove the screw from the lens.

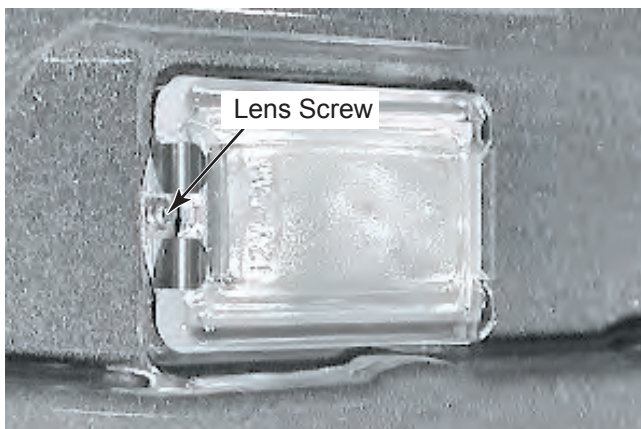

- b) Unclip the lens from the socket and remove the lens.

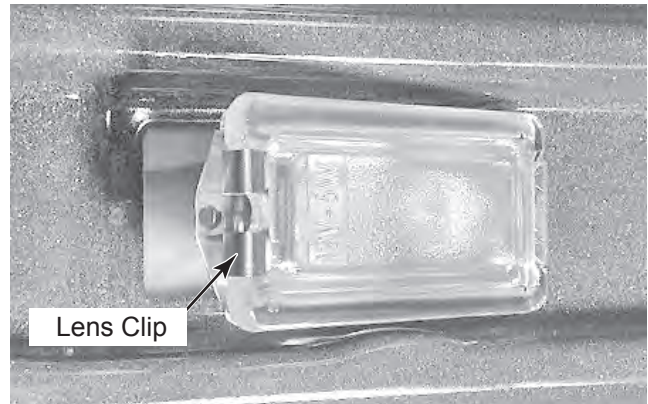

- c) Remove the halogen bulb from the socket connector.

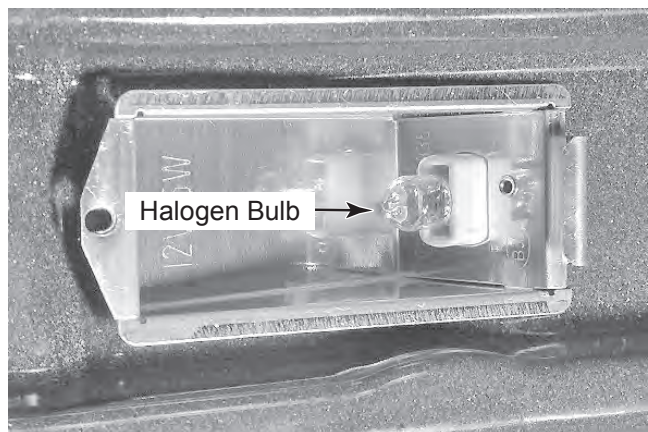

- d) Cut the wires near the socket body and splice the new socket in its place.

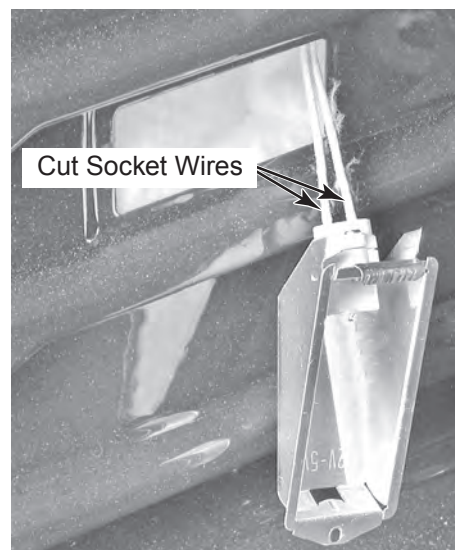

4. To remove the meat probe jack:

- a) Remove the nut from the meat probe jack.

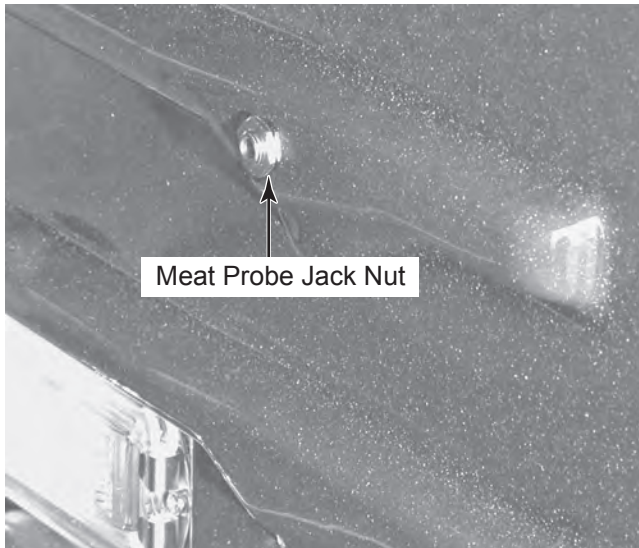

- b) Remove the oven from its mounting location (see "Installation Information" in Section 2) and pull it forward so that you can access the meat probe jack access cover on the right side of the oven.



- c) Use a pair of side-cutters and cut the meat probe jack access cover from the right side cover (see the top right photo).



- d) Remove the meat probe jack from the right side cover.
- e) Disconnect the wires from the meat probe jack terminals. **NOTE:** Make sure that you reinstall the star washer on the new jack when you install it.

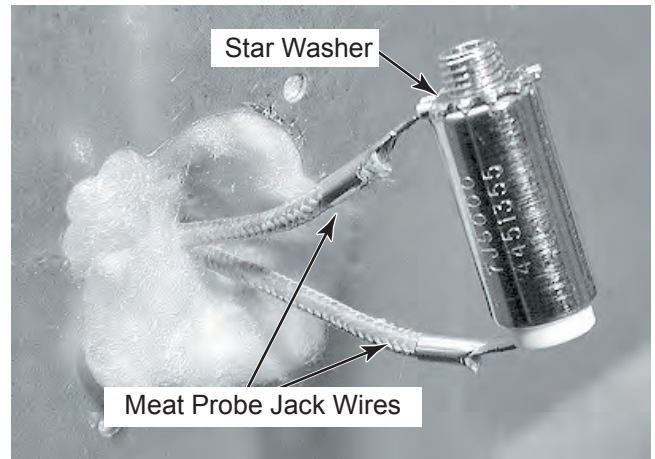

- f) Mount the meat probe jack access cover to the side cover with two screws.

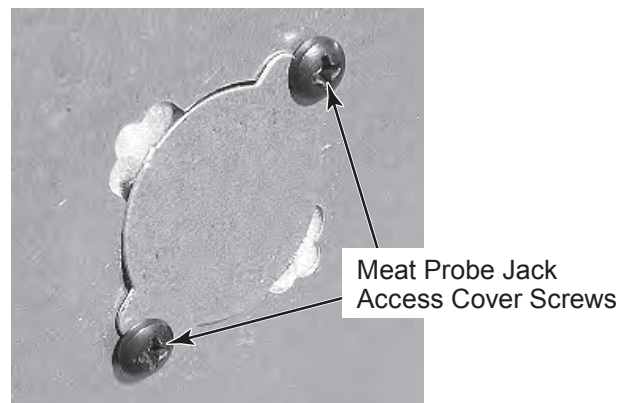

REMOVING THE BLOWER ASSEMBLY, BLOWER SPEED RESISTOR, AND OVEN SHUTDOWN THERMAL CUTOFF

⚠ WARNING



Electrical Shock Hazard

Disconnect power before servicing.
Replace all parts and panels before operating.

Failure to do so can result in death or electrical shock.

1. Unplug oven or disconnect power.
2. Remove the oven from its mounting location (see "Installation Information" in Section 2) and pull it forward so that you can access the top cover.
3. Remove the four screws from the top cover and remove the cover.

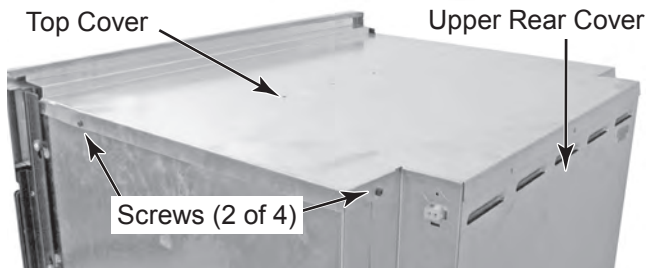

4. Remove the ten screws from the upper rear cover of the oven and remove the cover.

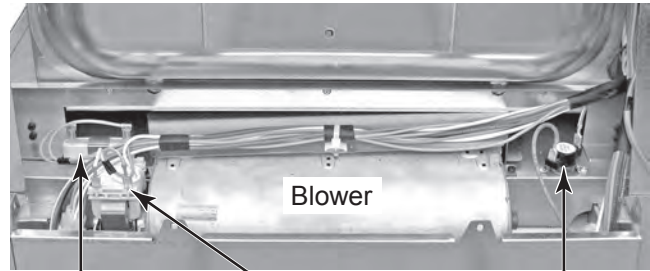
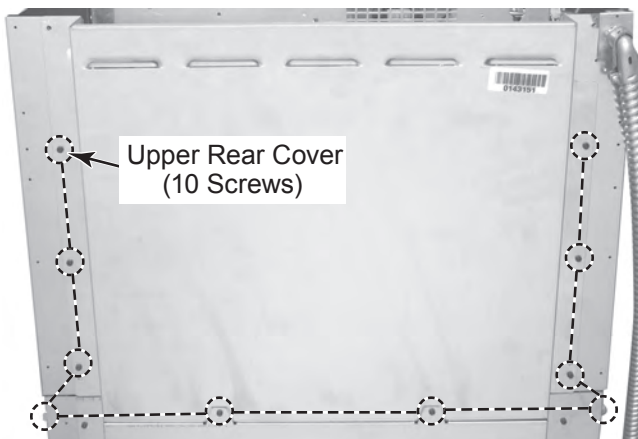

Blower Speed Resistor Blower Motor Oven Shutdown TCO

5. **To remove the blower assembly:**
 - a) Disconnect the white and gray wires from the blower motor terminals.
 - b) Remove the two screws from the blower brackets.
 - c) Pull back on the blower assembly while rotating it upwards and remove the assembly.

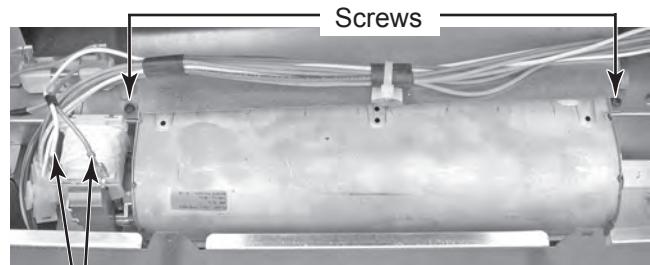

6. **To remove the blower speed resistor:**
 - a) Disconnect the two gray wires from the resistor terminals.
 - b) Remove the screw from the resistor bracket and remove the resistor.

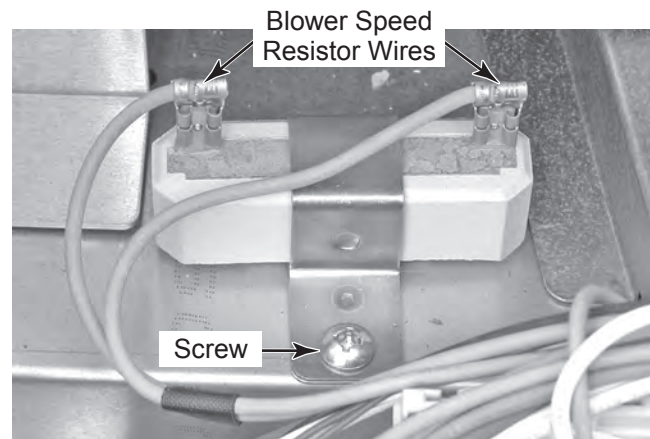

7. **To remove the oven shutdown thermal cutoff (TCO):**

- a) Disconnect the two red wires from the TCO terminals.
- b) Remove the two mounting screws and remove the TCO.

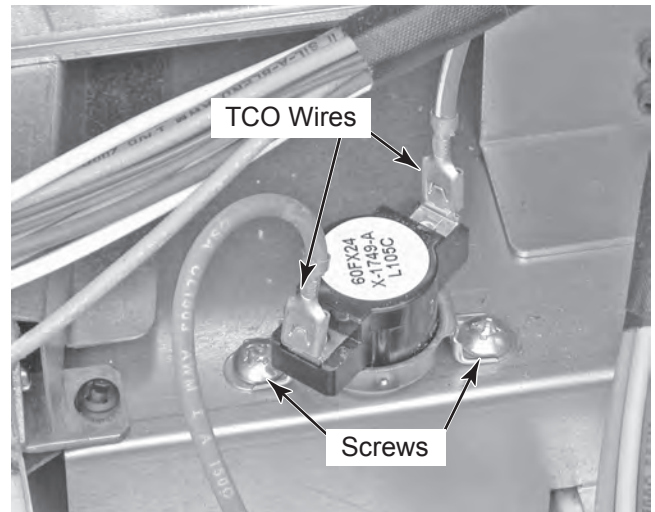

REMOVING THE HIDDEN BAKE ELEMENT

⚠ WARNING



Electrical Shock Hazard

**Disconnect power before servicing.
Replace all parts and panels before
operating.**

**Failure to do so can result in death or
electrical shock.**

1. Unplug oven or disconnect power.
2. Remove the oven from its mounting location (see “Installation Information” in Section 2) and pull it forward so that you can access the top cover.
3. Remove the four screws from the top cover and remove the cover.

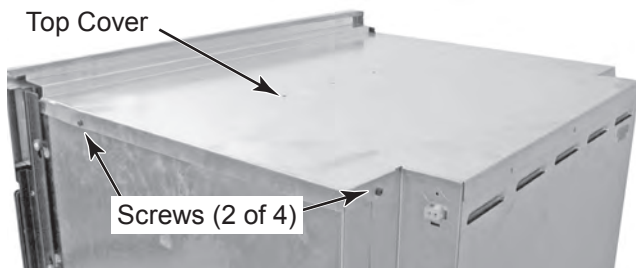

4. Remove the twelve screws from the lower rear cover and remove the cover.

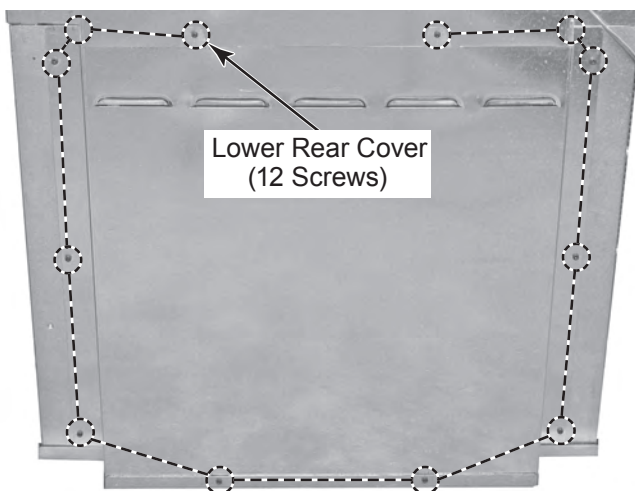

5. Disconnect the two red wires from the hidden bake element terminals.
6. Remove the four screws from the hidden bake element cover.

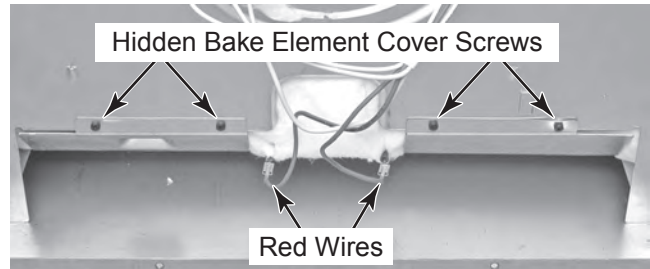

7. Bend the hidden bake element cover flaps down as far as possible.
8. Using a single-edge razor blade, cut the insulation blanket along the bracket edge of the hidden bake element. Spread the blanket apart so you can access the bracket screws.

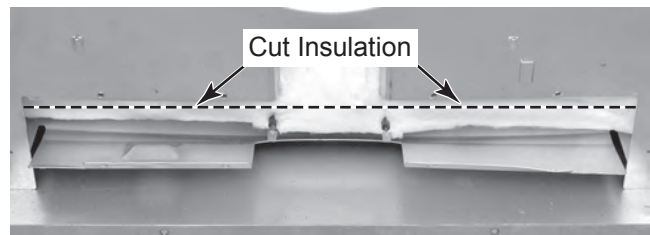

9. Remove the four screws from the hidden bake element bracket.

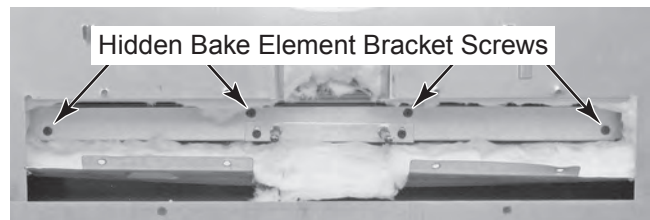

NOTE: When you remove the hidden bake element, press down on the front edge of the panel that is below the element so that it does not interfere with the removal.

10. Pull the hidden bake element out and remove it from the bottom of the oven.
11. Remove the two bracket screws from the hidden bake element and remove the bracket from the element.

REASSEMBLY NOTE: When you install the replacement hidden bake element, press down on the front edge of the panel that is below the element so that it does not interfere with the installation. When installed, the edge of the panel should be below the element bracket so that the bracket fits flush against the chassis.

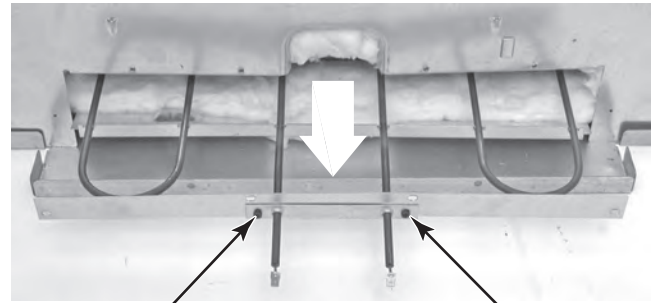

Hidden Bake Element Bracket Screws

REMOVING THE OVEN DOOR GLASS AND HANDLE

1. Open the lower oven door.
2. Raise the two door hinge tabs to the “unlocked” position.

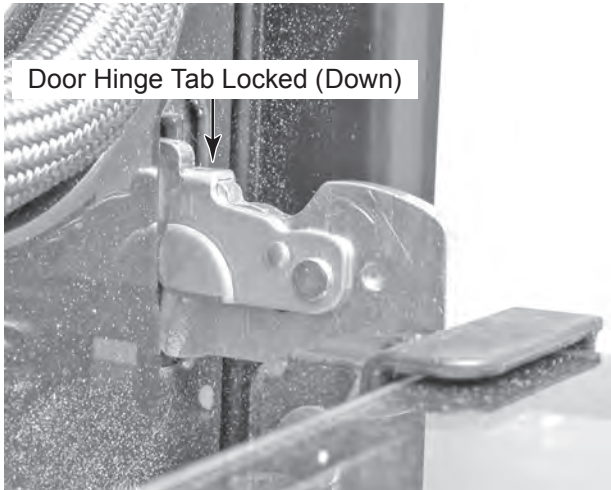

3. Close the oven door to within several inches, lift and pull out on the hinges, and remove them from the oven slots.
4. Place the oven door front side down on a padded surface to protect the finish.
5. Remove the two screws from each of the bottom corner glass holders and remove the holders.
6. **To remove the inner oven door glass panels**, lift each of the three glass panels, and remove them from the door.

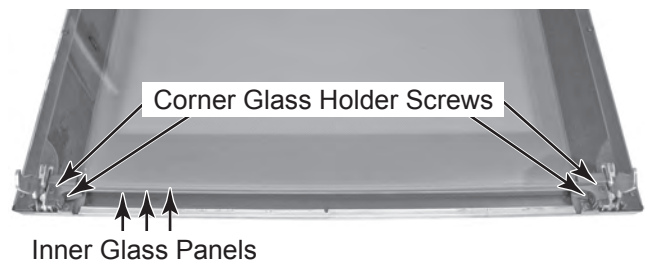

7. **To remove the door handle and outer oven door glass:**
 - a) Remove the three inner glass panels (see step 6).
 - b) Remove the three screws from the air vent and remove the vent.

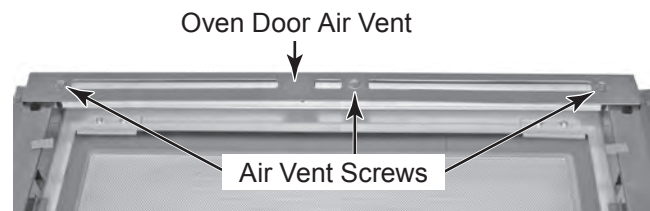

- c) Remove the four door handle bracket screws and remove the brackets and handle from the door.
- d) Slide the bottom edge of the outer oven door glass out of the door frame and remove the glass.

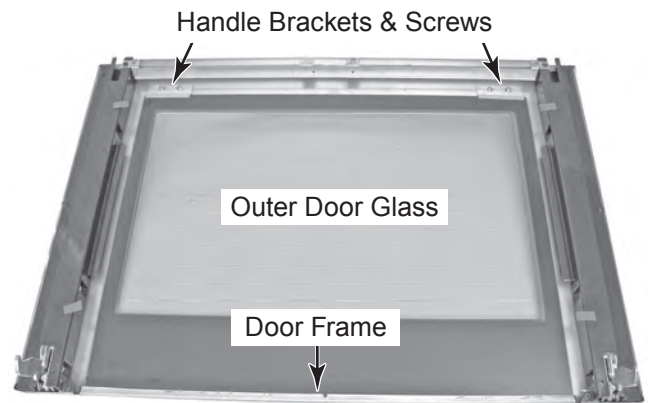

REMOVING THE OVEN DOOR GASKET

1. Remove the lower oven door (see the procedure on page 4-40).
2. Remove the screw from the door gasket retainer and remove the retainer.
3. Pull the door gasket clips out of the oven liner holes and remove the gasket.

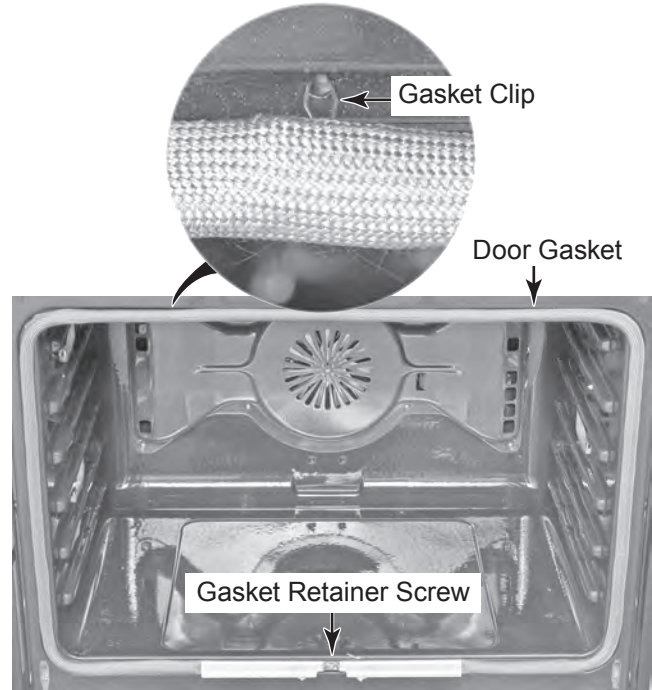

COMPONENT TESTING

UPPER OVEN COMPONENTS

- Unplug oven or disconnect power.
- Remove the lead wires from the related component before conducting any of the following tests.
- Discharge the high-voltage capacitor and remove the lead wires from the primary winding of the high-voltage transformer before conducting any of the following tests.
- All operational checks using microwave energy must be done with the microwave oven loaded with a minimum of 8 oz (250mL) of water in a microwave safe container.
- Conduct a microwave energy test after performing any tests or repairs to the microwave oven.
- Check that all wire leads are in the correct position before operating the microwave oven.
- Grasp wire connectors when removing the wire leads from microwave to oven parts.
- All testing must be done with an ohmmeter having a sensitivity of 20,000 ohms per volt DC or greater, and powered by at least a 9-volt battery.

	⚠ WARNING
	Electrical Shock Hazard Disconnect power before servicing. Replace all parts and panels before operating. Failure to do so can result in death or electrical shock.

HUMIDITY SENSOR



Refer to page 4-3 for the procedure for accessing the humidity sensor.

1. Unplug oven or disconnect power.
2. Disconnect the humidity sensor wire connector (HUM) from the appliance manager board.
3. Set the ohmmeter to the R x 1K scale.
4. Touch the ohmmeter test leads to the humidity sensor connector pins 1 & 3, and 2 & 3. The meter should indicate approximately 2.8 K Ω @ 77°F (25°C).

CAVITY THERMOSTAT



Refer to page 4-3 for the procedure for accessing the cavity thermostat.

1. Unplug oven or disconnect power.
2. Disconnect one of the wires from the cavity thermostat terminals.
3. Set the ohmmeter to the R x 1 scale.
4. Touch the ohmmeter test leads to the thermostat terminals. The meter should indicate a closed (0 Ω) circuit.

NOTE: The thermostat opens at 347°F (175°C).

! WARNING



Electrical Shock Hazard

**Disconnect power before servicing.
Replace all parts and panels before operating.
Failure to do so can result in death or electrical shock.**

MICROWAVE LIGHT TRANSFORMER

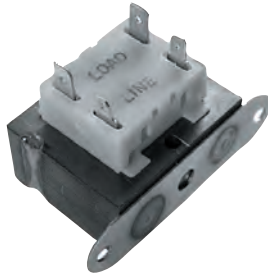

Refer to page 4-4 for the procedure for accessing the microwave light transformer.

1. Unplug oven or disconnect power.
2. Disconnect one of the wires from the LINE (primary) and one from the LOAD (secondary) terminals.
3. Set the ohmmeter to the R x 1 scale.
4. Touch the ohmmeter test leads to the LINE terminals. The meter should indicate approximately 45 Ω .
5. Touch the ohmmeter test leads to the LOAD terminals. The meter should indicate approximately 0.6 Ω .

CONVECTION THERMOACTUATOR

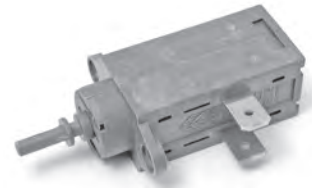

Refer to page 4-5 for the procedure for accessing the convection thermoactuator.

1. Unplug oven or disconnect power.
2. Disconnect one of the wires from the thermoactuator terminals.
3. Set the ohmmeter to the R x 1 scale.
4. Touch the ohmmeter test leads to the thermoactuator terminals. The meter should indicate approximately 2.3 Ω .

! WARNING



Electrical Shock Hazard

**Disconnect power before servicing.
Replace all parts and panels before operating.
Failure to do so can result in death or electrical shock.**

MONITOR FUSE



Refer to page 4-6 for the procedure for accessing the monitor fuse.

1. Unplug oven or disconnect power.
2. Disconnect one of the wires from the fuse holder terminals.
3. Set the ohmmeter to the R x 1 scale.
4. Touch the ohmmeter test leads to the fuse holder terminals. The meter should indicate a closed circuit (0 Ω).

MICROWAVE DOOR INTERLOCK SWITCHES



Refer to page 4-7 for the procedure for accessing the microwave door interlock switches.

1. Unplug oven or disconnect power.
2. Disconnect one of the wires from the door interlock switch terminals.
3. Set the ohmmeter to the R x 1 scale.
4. Touch the ohmmeter test leads to the COM and N.O. terminals of the door interlock switch. The meter should indicate an open circuit (infinite).
5. Press the actuator button on the interlock switch. The meter should indicate a closed circuit (0 Ω).

! WARNING



Electrical Shock Hazard

Disconnect power before servicing.
Replace all parts and panels before operating.
Failure to do so can result in death or electrical shock.

MAGNETRON THERMOSTAT



Refer to page 4-9 for the procedure for accessing the magnetron thermostat.

1. Unplug oven or disconnect power.
2. Disconnect one of the wires from the magnetron thermostat terminals.
3. Set the ohmmeter to the R x 1 scale.
4. Touch the ohmmeter test leads to the thermostat terminals. The meter should indicate a closed (0Ω) circuit.

NOTE: The thermostat opens at 257°F (125°C) and closes at 185°F (85°C).

MAGNETRON

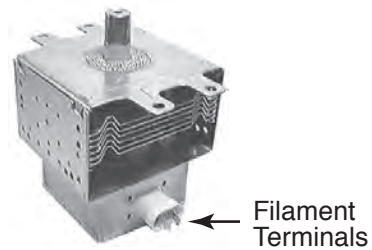

Refer to page 4-9 for the procedure for accessing the magnetron.

1. Unplug oven or disconnect power.
2. Touch a screwdriver shaft to the filament wire terminals and the chassis.
3. Disconnect one of the wires from the magnetron filament terminals.
4. Set the ohmmeter to the R x 1 scale.
5. Touch the ohmmeter test leads to the filament terminals. The meter should indicate less than 1Ω .
6. Touch one of the ohmmeter test leads to each of the filament terminals and the other lead to the chassis. The meter should indicate an open (infinite) circuit for both terminals.



! WARNING

Electrical Shock Hazard

Disconnect power before servicing.
Replace all parts and panels before operating.
Failure to do so can result in death or electrical shock.

MAIN L1 & L2 FILTERS

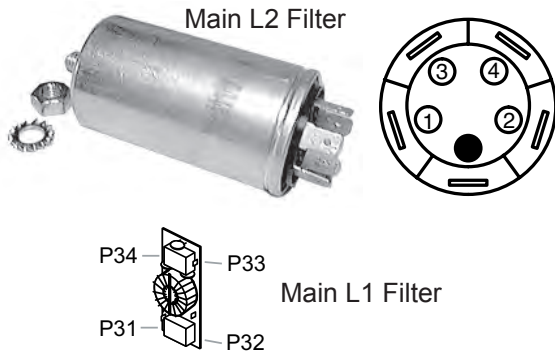

Refer to page 4-11 for the procedure for accessing the main L1 and L2 filters.

1. Unplug oven or disconnect power.
2. **IMPORTANT:** Discharge the main L2 filter by touching the leads of a 20,000 ohm resistor to the terminals and chassis ground.
3. Disconnect the wires from the main L1 or L2 filter terminals.
4. Set the ohmmeter to the R x 1 scale.
5. Touch the ohmmeter test leads to the following L1 filter terminals:
Connectors P31 & P32, and P33 & P34 = 300 Ω or more (100 Ω or less is abnormal).
Connectors P31 & P34, and P32 & P33 = 0 Ω (100K Ω or more is abnormal).
6. Touch the ohmmeter test leads to the following L2 filter terminals:
Terminals 1 and 3 = less than 1 Ω .
Terminals 2 and 4 = less than 1 Ω .
Terminals 3 and 4 = 660 to 700 Ω .

GRILL & CONVECTION THERMOSTATS

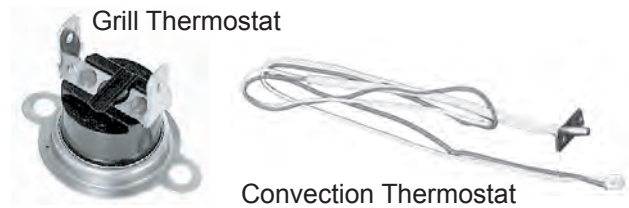

Refer to page 4-11 for the procedure for accessing the grill thermostat, and page 4-22 for the convection thermostat.

1. Unplug oven or disconnect power.
2. Disconnect one of the wires from the thermostat terminals.
3. Set the ohmmeter to the R x 1 scale.
4. Touch the ohmmeter test leads to the thermostat terminals. The meter should indicate a closed (0 Ω) circuit.

NOTE: The grill thermostat opens at 266°F (130°C) and closes at -31°F (-35°C).

The convection thermostat opens at 293°F (145°C) and closes at 221°F (105°C).

! WARNING

Electrical Shock Hazard

Disconnect power before servicing.
Replace all parts and panels before operating.
Failure to do so can result in death or electrical shock.



MAGNETRON FAN MOTOR



Refer to page 4-13 for the procedure for accessing the magnetron fan motor.

1. Unplug oven or disconnect power.
2. Disconnect one of the wires from the magnetron fan motor terminals.
3. Set the ohmmeter to the R x 1 scale.
4. Touch the ohmmeter test leads to the motor terminals. The meter should indicate approximately 3 Ω .

MICROWAVE INVERTER BOARD

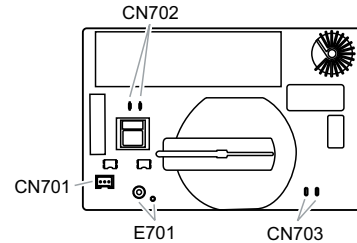

Refer to page 4-13 for the procedure for accessing the inverter.

1. Unplug oven or disconnect power.
2. Visually inspect connectors CN701, CN702, CN703, and E701 on the microwave inverter board and check for signs of overheating, or any failures due to loose wires, bad crimping, etc.



⚠ WARNING

Electrical Shock Hazard

Disconnect power before servicing.
Replace all parts and panels before operating.
Failure to do so can result in death or electrical shock.

GRILL ELEMENT

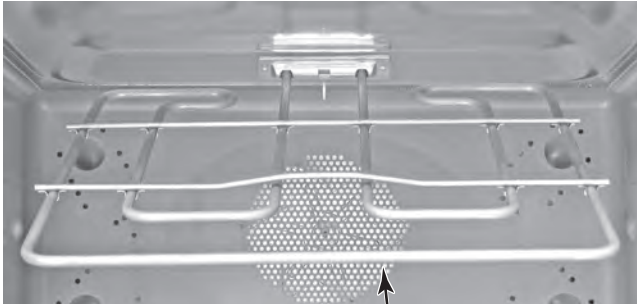

Grill Element

Refer to page 4-16 for the procedure for accessing the grill element.

1. Unplug oven or disconnect power.
2. Disconnect one of the wires from the grill element terminals.
3. Set the ohmmeter to the R x 1 scale.
4. Touch the ohmmeter test leads to the grill element terminals. The meter should indicate approximately 9 Ω .

LOWER OVEN LIGHT TRANSFORMER

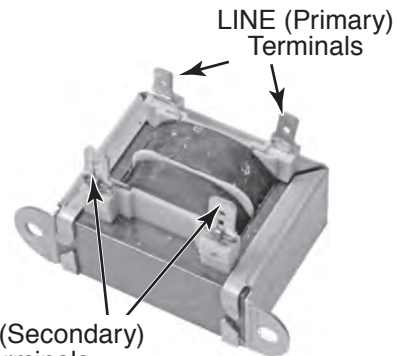

LOAD (Secondary) Terminals

Refer to page 4-20 for the procedure for accessing the lower oven light transformer.

1. Unplug oven or disconnect power.
2. Disconnect one of the wires from the LINE (primary) and one from the LOAD (secondary) terminals.
3. Set the ohmmeter to the R x 1 scale.
4. Touch the ohmmeter test leads to the LINE terminals. The meter should indicate approximately 40 to 45 Ω .
5. Touch the ohmmeter test leads to the LOAD terminals. The meter should indicate less than 1 Ω .

! WARNING



Electrical Shock Hazard

**Disconnect power before servicing.
Replace all parts and panels before operating.
Failure to do so can result in death or electrical shock.**

MICROWAVE CONVECTION RING ELEMENT



Refer to page 4-22 for the procedure for accessing the microwave convection ring element.

1. Unplug oven or disconnect power.
2. Disconnect one of the wires from the convection ring element terminals.
3. Set the ohmmeter to the R x 1 scale.
4. Touch the ohmmeter test leads to the convection ring element terminals. The meter should indicate approximately 12 Ω .

MICROWAVE CONVECTION FAN MOTOR



Refer to page 4-22 for the procedure for accessing the microwave convection fan motor.

1. Unplug oven or disconnect power.
2. Disconnect one of the wires from the convection fan motor terminals.
3. Set the ohmmeter to the R x 1 scale.
4. Touch the ohmmeter test leads to the fan motor terminals. The meter should indicate approximately 45 Ω .

⚠ WARNING



Electrical Shock Hazard

Disconnect power before servicing.
Replace all parts and panels before operating.
Failure to do so can result in death or electrical shock.

TURNTABLE MOTOR



Refer to page 4-24 for the procedure for accessing the turntable motor.

1. Unplug oven or disconnect power.
2. Disconnect one of the wires from the turntable motor terminals.
3. Set the ohmmeter to the R x 1K scale.
4. Touch the ohmmeter test leads to the turntable motor terminals. The meter should indicate approximately 2450 Ω .

MEASURE OVEN INPUT CURRENT

Connect an ammeter (Valhalla Scientific 2101 or equivalent recommended) to measure the input current of microwave oven when the power level is set to Level 10 at the touch panel.

If more than 0.5A:

The 900W inverter is probably OK. Check the magnetron. See Magnetron test on page 5-4.

If less than 0.5A:

There is no input to the 900W inverter.

Check the following:

1. Unplug oven or disconnect power.
2. No AC voltage supply. Check relay control board and wiring.
3. No control signal. Check relay control board and wiring.

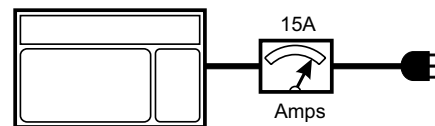

LOWER OVEN COMPONENTS



! WARNING

Electrical Shock Hazard

Disconnect power before servicing.

Replace all parts and panels before operating.

Failure to do so can result in death or electrical shock.

DOOR LATCH ASSEMBLY

Refer to page 4-28 for the procedure for accessing the door latch assembly.

NOTE: The door latch assembly components will be tested at the appliance manager board (see page 4-18).

1. Unplug oven or disconnect power.
2. Set the ohmmeter to the R x 1K scale.
3. Touch the ohmmeter test leads to the wire connectors. The meter should indicate as shown below:

Latch Switch: P1-4 (TN) and P1-5 (BR). The meter should indicate an open circuit (infinite) with door unlocked, and a closed circuit (0 Ω) with the door locked.

Door Switch: P1-7 (OR) and P1-5 (BR). The meter should indicate an open circuit (infinite) with door unlocked, and a closed circuit (0 Ω) with the door locked.

Latch Motor: P8-5 (YL) and the neutral (WH) stud on the AC terminal block. The meter should indicate approximately 2450 Ω .

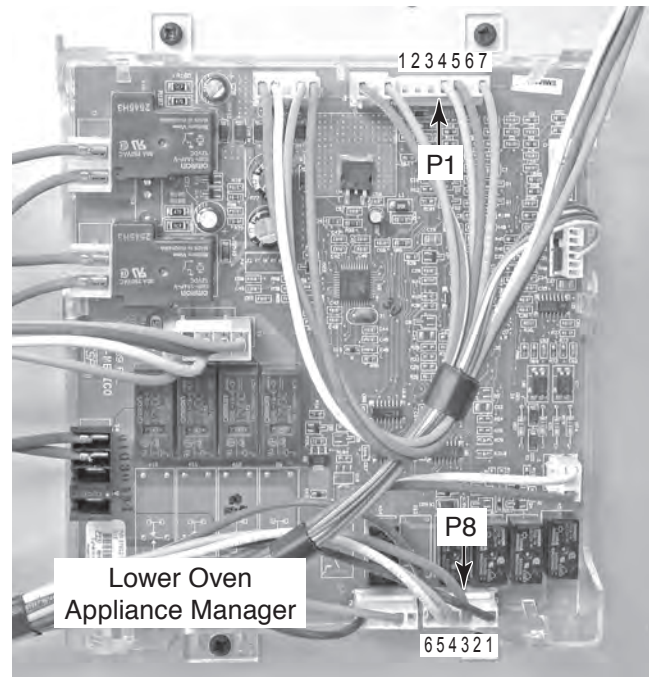



⚠ WARNING

Electrical Shock Hazard

Disconnect power before servicing.
Replace all parts and panels before operating.
Failure to do so can result in death or electrical shock.

BROIL ELEMENT

Refer to page 4-30 for the procedure for accessing the broil element.

NOTE: The broil element will be tested at the appliance manager board (see page 4-18).

1. Unplug oven or disconnect power.
2. Set the ohmmeter to the R x 1 scale.
3. Touch the ohmmeter test leads to the wire connectors. The meter should indicate as shown below:

Inner Element: T3-4 (OR) and T1-1 (RD).
The meter should indicate between 31 and 36 Ω .

Outer Element: T3-1 (BU) and T2-2 (R/W).
The meter should indicate between 53 and 59 Ω .

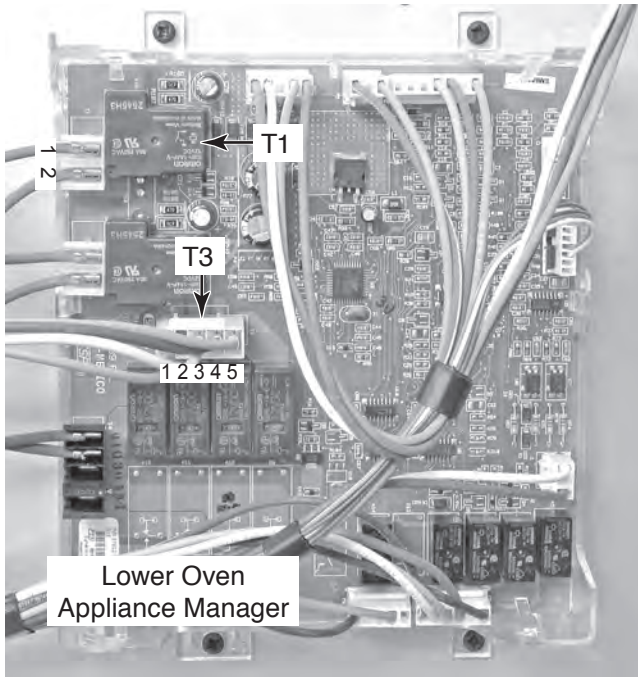

OVEN TEMPERATURE SENSOR

Refer to page 4-30 for the procedure for accessing the oven temperature sensor.

NOTE: The oven temperature sensor will be tested at the appliance manager board (see page 4-18).

1. Unplug oven or disconnect power.
2. Set the ohmmeter to the R x 1K scale.
3. Touch the ohmmeter test leads to P2-1 (V) and P2-2 (V). The meter should indicate approximately 1091 Ω @ 75°F (23.9°C).

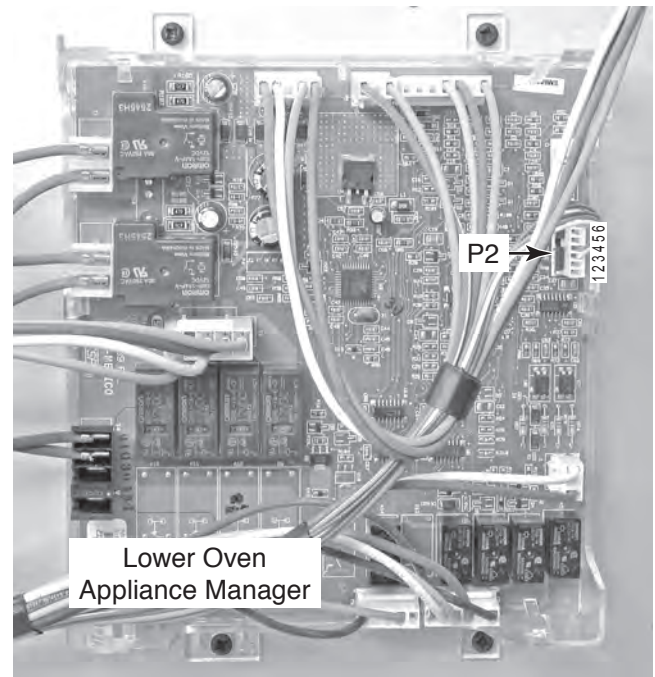



! WARNING

Electrical Shock Hazard

Disconnect power before servicing.
Replace all parts and panels before operating.
Failure to do so can result in death or electrical shock.

CONVECTION RING ELEMENT

Refer to page 4-32 for the procedure for accessing the convection ring element.

NOTE: The convection ring element will be tested at the appliance manager board (see page 4-18).

1. Unplug oven or disconnect power.
2. Set the ohmmeter to the R x 1 scale.
3. Touch the ohmmeter test leads to wire connectors T3-2(YL) and T2-2(R/W). The meter should indicate between 33 and 37 Ω .

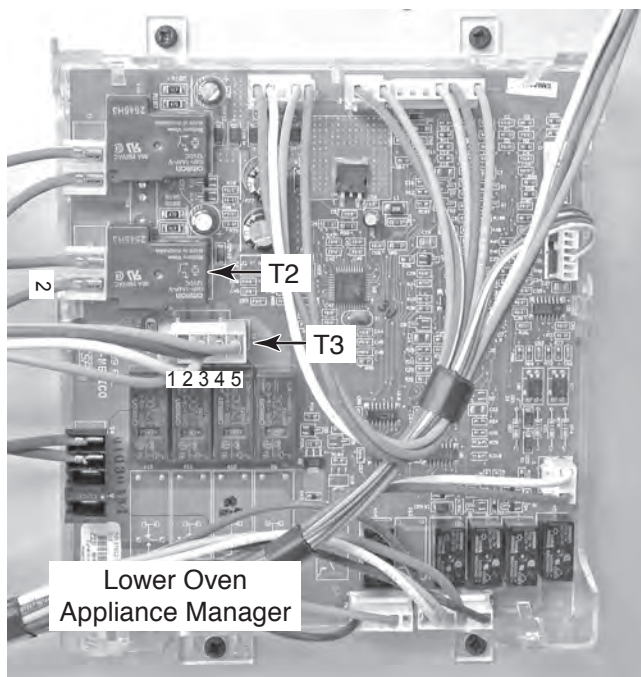

CONVECTION FAN MOTOR

Refer to page 4-32 for the procedure for accessing the convection fan motor.

NOTE: The convection fan motor will be tested at the appliance manager board (see page 4-18).

1. Unplug oven or disconnect power.
2. Set the ohmmeter to the R x 1 scale.
3. Touch the ohmmeter test leads to wire connector P8-3 (OR) and the neutral (WH) stud on the AC terminal block. The meter should indicate approximately 18 Ω .

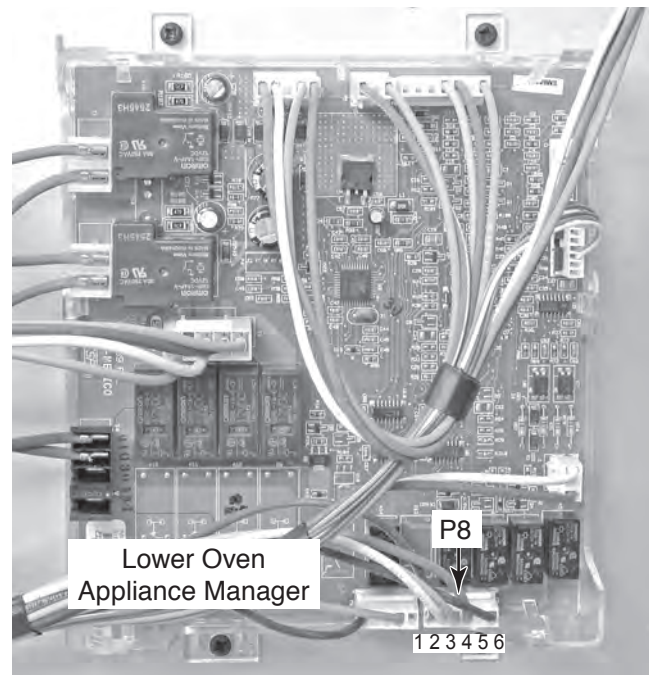



⚠ WARNING

Electrical Shock Hazard

Disconnect power before servicing.
Replace all parts and panels before operating.
Failure to do so can result in death or electrical shock.

MEAT PROBE JACK

Refer to page 4-34 for the procedure for accessing the meat probe jack.

NOTE: The meat probe jack will be tested at the appliance manager board (see page 4-18).

1. Unplug oven or disconnect power.
2. Set the ohmmeter to the R x 1 scale.
3. Touch the ohmmeter test leads to wire connectors P2-6 (WH) and P2-5 (OR). The meter should indicate approximately 78 Ω @ 60°F (15.6°C).

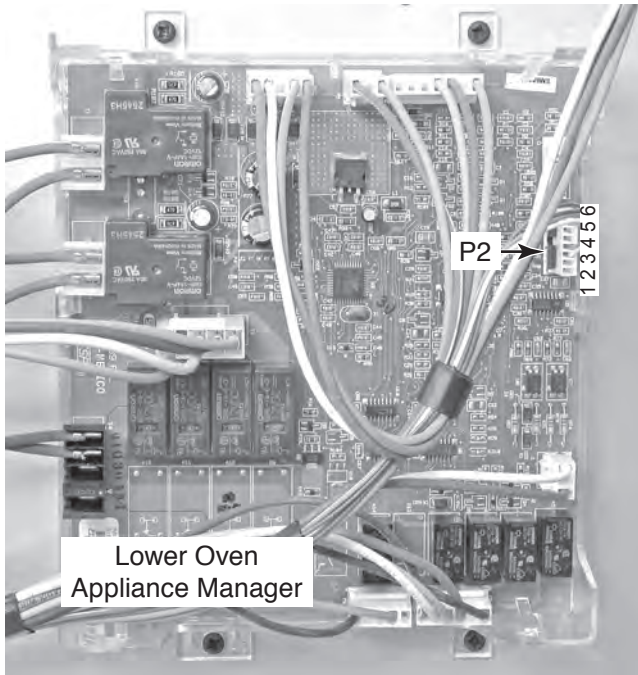

BLOWER MOTOR

Refer to page 4-36 for the procedure for accessing the blower motor.

NOTE: The blower motor will be tested at the appliance manager board (see page 4-18).

1. Unplug oven or disconnect power.
2. Set the ohmmeter to the R x 1 scale.
3. Touch the ohmmeter test leads to wire connector P9-2 (GY) and the neutral (WH) wire at the AC terminal block. The meter should indicate between 181 and 240 Ω .

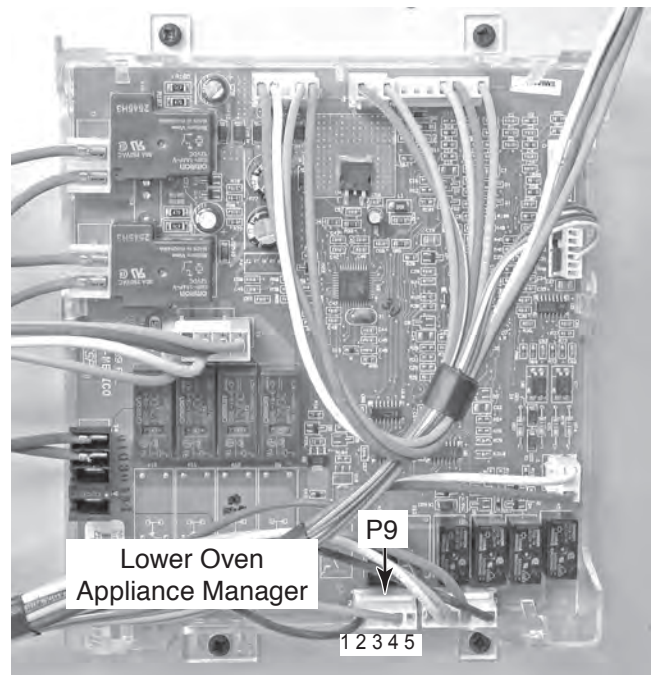



! WARNING

Electrical Shock Hazard

Disconnect power before servicing.
Replace all parts and panels before operating.
Failure to do so can result in death or electrical shock.

BLOWER SPEED RESISTOR

Refer to page 4-36 for the procedure for accessing the blower speed resistor.

NOTE: The blower speed resistor will be tested at the appliance manager board (see page 4-18).

1. Unplug oven or disconnect power.
2. Set the ohmmeter to the R x 1 scale.
3. Touch the ohmmeter test leads to wire connectors P9-2 (GY) and P8-4 (GY). The meter should indicate approximately 170 Ω .

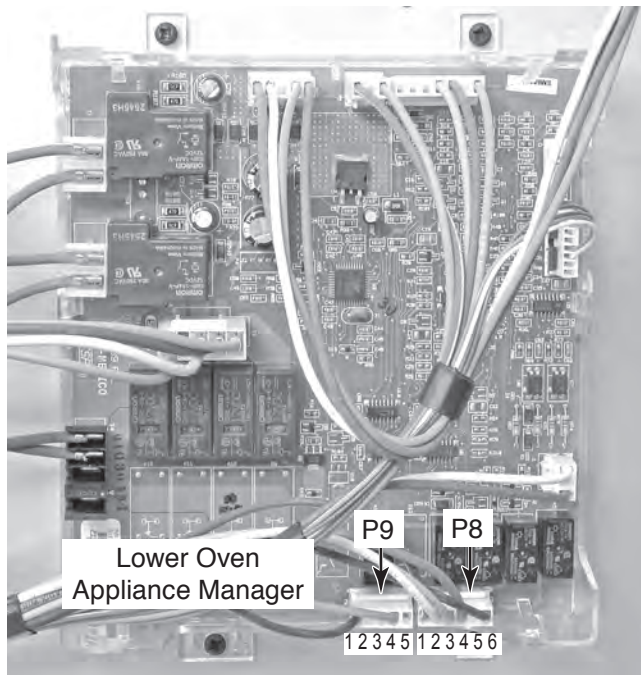

OVEN SHUTDOWN THERMAL CUTOFF (TCO)

Refer to page 4-36 for the procedure for accessing the oven shutdown thermal cutoff.

NOTE: The oven shutdown thermal cutoff will be tested at the appliance manager board (see page 4-18).

1. Unplug oven or disconnect power.
2. Set the ohmmeter to the R x 1 scale.
3. Touch the ohmmeter test leads to wire connectors T1-2 (R/W) and P7-3 (RD). The meter should indicate a closed circuit (0 Ω).

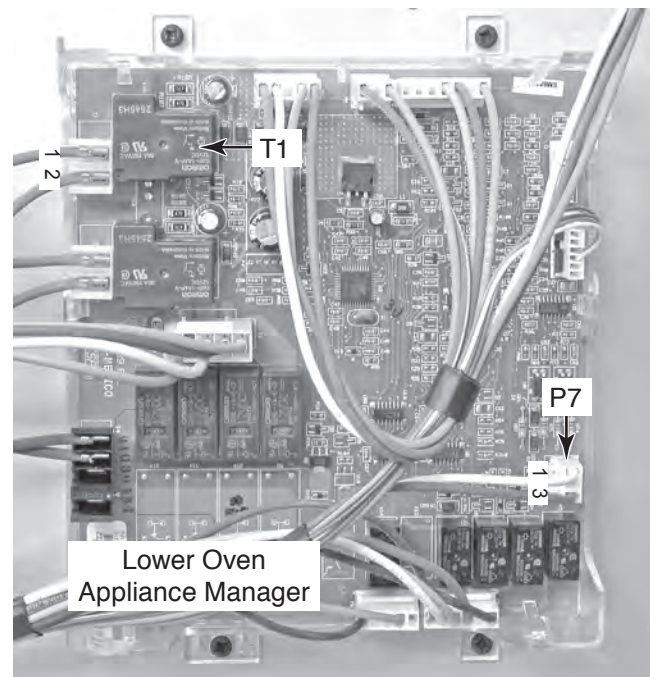



⚠ WARNING

Electrical Shock Hazard

Disconnect power before servicing.
Replace all parts and panels before operating.
Failure to do so can result in death or electrical shock.

HIDDEN BAKE ELEMENT

Refer to page 4-38 for the procedure for accessing the hidden bake element.

NOTE: The hidden bake element will be tested at the appliance manager board (see page 4-18).

1. Unplug oven or disconnect power.
2. Set the ohmmeter to the R x 1 scale.
3. Touch the ohmmeter test leads to wire connectors T3-3 (RD) and T1-1 (RD). The meter should indicate between 26 and 30 Ω .

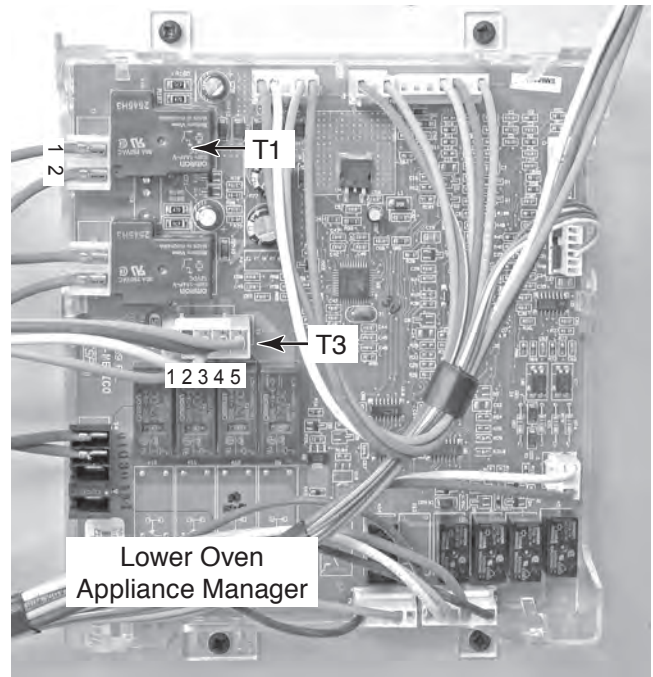

— NOTES —

DIAGNOSTICS & TROUBLESHOOTING



⚠ WARNING

Electrical Shock Hazard

Disconnect power before servicing.

Replace all parts and panels before operating.

Failure to do so can result in death or electrical shock.

IMPORTANT

Electrostatic Discharge (ESD) Sensitive Electronics

ESD problems are present everywhere. ESD may damage or weaken the electronic control assembly. The new control assembly may appear to work well after repair is finished, but failure may occur at a later date due to ESD stress.

- Use an anti-static wrist strap. Connect wrist strap to green ground connection point or unpainted metal in the appliance.

-OR-

Touch your finger repeatedly to a green ground connection point or unpainted metal in the appliance.

- Before removing the part from its package, touch the anti-static bag to a green ground connection point or unpainted metal in the appliance.
- Avoid touching electronic parts or terminal contacts; handle electronic control assembly by edges only.
- When repackaging failed electronic control assembly in anti-static bag, observe above instructions.

DIAGNOSTICS

- Is oven in “Sabbath Mode”? If so “SAB” will appear in the digital display. Press OPTIONS and “7” to end Sabbath mode. This will return to BAKE mode for an untimed bake.

Disconnect power and perform the following checks:

- A potential cause of a control not functioning is corrosion on connections. Observe connections and check for continuity with an ohmmeter.
- All tests/checks should be made with a VOM or DVM having a sensitivity of 20,000 ohms per volt DC or greater.
- Check all connections before replacing components, looking for broken or loose wires, failed terminals, or wires not pressed into connectors far enough. Damaged harness must be entirely replaced. Do not re-work a harness.
- Voltage checks must be made with all connectors attached to the boards.
- Resistance checks must be made with power cord unplugged from outlet, and with wiring harness or connectors disconnected.

**PRECAUTIONS TO BE
OBSERVED BEFORE AND
DURING SERVICING TO AVOID
POSSIBLE EXPOSURE TO
EXCESSIVE MICROWAVE ENERGY**

- a. Do not operate or allow the oven to be operated with the door open.
- b. Make the following safety checks on all ovens to be serviced before activating the magnetron or other microwave source, and make repairs as necessary:
 1. Interlock Operation
 2. Proper Door Closing
 3. Seal and Sealing Surfaces (Arcing, Wear and Other Damage)
 4. Damage to or Loosening of Hinges and Latches
 5. Evidence of Dropping or Abuse
- c. Before turning on microwave power for any service test or inspection within the microwave generating compartments, check the magnetron, waveguide or transmission line and cavity for proper alignment, integrity and connections.
- d. Any defective or misadjusted components in the interlock, monitor, door seal, and microwave generation, and transmission systems shall be repaired, replaced, or adjusted by procedures described in service manual before the oven is released to the owner.
- e. A microwave leakage check to verify compliance with the Federal performance standard should be performed on each oven prior to release to the owner.
- f. Do not attempt to operate the oven if the door glass is broken.

FAILURE / ERROR DISPLAY CODES

Before proceeding with any corrective action, perform the following steps to enter the Diagnostic mode.

1. Press the OFF key.
2. Press the OFF key.
3. Press the START key. If control does not enter Diagnostics, repeat steps.

Screen 1:

- A. Main clock hours display shows latch state in first display position, and door state in second position.
- B. Main clock minutes display show the model select state associated with control system.
- C. Main temperature display shows the cavity temperature.
- D. Lower text line shows software versions for appliance manager (AM), user interface (UI) and EEPROM version.
Press key #6 to scroll to next screen.

Screen 2:

Screen displays programmed cavity size.
Press key #6 to scroll to next screen.

Screen 3:

Displays the last error code in memory. If GOOD is displayed there is not an error coded in memory.

To Clear Last Error Code

- A. Unplug oven or disconnect power.
- B. Wait 10 seconds, reconnect or plug in oven.
- C. Enter Diagnostics mode by pressing OFF, OFF, START.
- D. Press key #6 to show cavity size select screen.
- E. Press key #6 to show error code.
- F. To edit press CLOCK key
- G. Press START key to clear last error. Control should display GOOD.

Troubleshooting Key strokes

- Press the Bake key activates Bake relay.
- Press Broil key once to activate Outer Broil, press again for Inner Broil.
- Press Convect Bake key activates Convect Ring and Fan.
- Press Self Clean key activates Latch Motor.
- Press Cook time key once to activate low speed, press again for high speed.



⚠ WARNING

Electrical Shock Hazard

Disconnect power before servicing.
Replace all parts and panels before operating.
Failure to do so can result in death or electrical shock.

FAILURE (Leftmost 2 Clock Digits)	ERROR (Rightmost 2 Clock Digits)	MESSAGE/DESCRIPTION
F0 Default	E0	No failure (GOOD)
F1 Component	E0	CHECK OVEN USER INTERFACE
PROCEDURE: Before proceeding, press OFF, OFF, START to enter the Diagnostic mode. A. Unplug oven or disconnect power. B. Replace oven user interface board. C. Replace all parts and panels before operating. D. Plug in oven or reconnect power. E. Verify operation is normal. Go to step 1 and complete checks.		
F1 Component	E1	CHECK OVEN APPLIANCE MANAGER
PROCEDURE: Before proceeding, press OFF, OFF, START to enter the Diagnostic mode. A. Unplug oven or disconnect power. B. Check oven door switch. If OK, go to step C. C. Replace oven appliance manager. D. Replace all parts and panels before operating. E. Plug in oven or reconnect power. F. Verify operation is normal. Press OFF, OFF, START to reenter the Diagnostic Mode and complete checks.		
F1 Component	E2	CHECK MICROWAVE USER INTERFACE
PROCEDURE: Before proceeding, press OFF, OFF, START to enter the Diagnostic mode. A. Unplug oven or disconnect power. B. Replace microwave user interface. C. Replace all parts and panels before operating. D. Plug in oven or reconnect power. E. Verify operation is normal. Press OFF, OFF, START to reenter the Diagnostic Mode and complete checks.		
F1 Component	E3	CHECK MICROWAVE APPLIANCE MANAGER
PROCEDURE: Before proceeding, press OFF, OFF, START to enter the Diagnostic mode. A. Unplug oven or disconnect power. B. Replace microwave appliance manager. C. Replace all parts and panels before operating. D. Plug in oven or reconnect power. E. Verify operation is normal. Press OFF, OFF, START to reenter the Diagnostic Mode and complete checks.		

FAILURE (Leftmost 2 Clock Digits)	ERROR (Rightmost 2 Clock Digits)	MESSAGE/DESCRIPTION
F1 Component	E4	CHECK MICROWAVE POWER RELAY
PROCEDURE: Before proceeding, press OFF, OFF, START to enter the Diagnostic mode. A. Unplug oven or disconnect power. B. Replace microwave power relay. C. Replace all parts and panels before operating. D. Plug in oven or reconnect power. E. Verify operation is normal. Press OFF, OFF, START to reenter the Diagnostic Mode and complete checks.		
F1 Component	E5	CHECK MICROWAVE INVERTER
PROCEDURE: Before proceeding, press OFF, OFF, START to enter the Diagnostic mode. A. Unplug oven or disconnect power. B. Replace microwave inverter. C. Replace all parts and panels before operating. D. Plug in oven or reconnect power. E. Verify operation is normal. Press OFF, OFF, START to reenter the Diagnostic Mode and complete checks.		
F1 Component	E6	CHECK MICROWAVE WAVE GUIDE
PROCEDURE: Before proceeding, press OFF, OFF, START to enter the Diagnostic mode. A. Unplug oven or disconnect power. B. Replace microwave wave guide. C. Replace all parts and panels before operating. D. Plug in oven or reconnect power. E. Verify operation is normal. Press OFF, OFF, START to reenter the Diagnostic Mode and complete checks.		
F2 Keypad	E0 E1	KEYPAD DISCONNECTED STUCK OR SHORTED KEY
PROCEDURE: Before proceeding, press OFF, OFF, START to enter the Diagnostic mode. A. Unplug oven or disconnect power. B. Check keypad connector for firm connection. C. Replace all parts and panels before operating. D. Plug in oven or reconnect power. E. If error code returns after 60 seconds proceed to step F. F. Unplug oven or disconnect power. G. Replace keypad.		

FAILURE (Leftmost 2 Clock Digits)	ERROR (Rightmost 2 Clock Digits)	MESSAGE/DESCRIPTION
		SUGGESTED CORRECTIVE ACTION PROCEDURE
<p>H. Replace all parts and panels before operating. I. Plug in oven or reconnect power. Wait 60 seconds. J. If error code returns after 60 seconds, proceed to step K. K. Unplug oven or disconnect power. L. Replace cable connecting user interface and keypad. M. Replace all parts and panels before operating. N. Plug in oven or reconnect power. Wait 60 seconds. O. If error code returns after 60 seconds, proceed to step P. P. Unplug oven or disconnect power. Q. Replace oven user interface. R. Replace all parts and panels before operating. S. Plug in oven or reconnect power. Wait 60 seconds. T. Verify operation is normal. Press OFF, OFF, START to reenter the Diagnostic Mode and complete checks.</p>		
F3 Sensors	E1 E3	LOWER MAIN OVEN SENSOR SHORTED OR OPEN MEAT PROBE SHORTED
<p>PROCEDURE: Before proceeding, press OFF, OFF, START to enter the Diagnostic mode.</p> <p>A. Verify cavity temperature on Screen 1. B. If dashes appear in main temperature display go to step C. C. Unplug oven or disconnect power. D. Remove back panels and ensure the indicated temperature sensor is plugged in properly and fully inserted. If not, plug in the connector and proceed to step I. If sensor is plugged in properly go to step E. E. Check connector P2 on the appliance manager. Ensure P2 connector is plugged in properly and fully inserted. If connector is inserted properly go to step I. If not go to step F. F. Visually inspect the wires between P2 on the appliance manager and the indicated temperature sensor. Make sure the wires are not pinched or cut. If wires appear intact, unplug P2 connector on the appliance manager. Go to step G. G. Measure the indicated sensor resistance value (measure between appropriate P2 connector pins). For the following sensors, the resistance value should read: LowerOvenSensor: Between 931 and 2869 Ω (Approx. 1080 Ω at room temp.) Meat Probe Sensor: Between 1,300 and 103,000 Ω (Approx. 59,000 Ω at room temp.) (Insert meat probe into meat probe jack located inside the oven cavity prior to reading resistance.) If indicated temperature sensor does not meet these requirements go to step H. If indicated temperature sensor does meet these requirements go to step J.</p> <p>H. For LOWER sensor: Replace appropriate temperature sensor. Repeat step G. If the requirements are not met, replace sensor harness. Repeat step G. For MEAT PROBE sensor: Replace meat probe sensor. Repeat step G. If the requirements are not met, replace sensor harness. Repeat step G. If the requirements are still not met, replace the meat probe jack. If the meat probe sensor is still not operating correctly go to step I.</p> <p>I. Replace the appliance manager. Ensure all connectors are properly placed and firmly connected. J. Replace all parts and panels before operating. K. Plug in oven or reconnect power. Wait 60 seconds. L. Enter into Diagnostic mode and read sensor for main oven sensor, warm drawer and meat probe on immediate display.</p>		
F3 Sensors	E2	WARMING DRAWER SENSOR SHORTED OR OPEN
<p>PROCEDURE: Oven is not equipped with this feature. If error occurs press OFF, OFF, START enter into Diagnostics Mode, then replace user interface with correct control associated with this product.</p>		
F4 Microwave Sensors	E1 E2 E4	CAVITY TEMPERATURE SENSOR ERROR INTERNAL TEMPERATURE SENSOR HUMIDITY SENSOR

FAILURE (Leftmost 2 Clock Digits)	ERROR (Rightmost 2 Clock Digits)	MESSAGE/DESCRIPTION
		SUGGESTED CORRECTIVE ACTION PROCEDURE
<p>PROCEDURE: There are three sensors for the microwave. They are the Cavity Sensor, Ambient Sensor (integrated on the MW appliance manager), and Humidity Sensor. Before proceeding, press OFF, OFF, START to enter the Diagnostic mode.</p> <p>A. Press the number "6" key to transition to the Sensors screen. B. Verify in diagnostics the temperature readings on sensor. C. The sensors for the combo microwave oven will scroll through the list of sensors. D. If a sensor reading on the display shows (---) dashes, the sensor is not connected or otherwise inoperable. If sensor that shows dashes is the ambient sensor, proceed to step O. E. Unplug oven or disconnect power. F. Remove top panel to gain access to the microwave control system. G. Ensure the cavity temperature sensor (P6) and the humidity sensor (P4) are plugged in properly to the appliance manager. If not, plug in the connector and proceed to step R. If connectors are plugged in proceed to step H. H. Visually inspect the wires between P4 and cavity sensor from the appliance manager to the back of the unit to ensure they are not pinched or cut. If wires appear to be intact, unplug connector and proceed to step I. I. Measure the indicated sensors resistance value from the P4 connector. For this sensor, the resistance value should read 231 kΩ at 25°C. J. Visually inspect the wires between P6 and humidity sensor from the appliance manager to the front of the unit to ensure they are not pinched or cut. If wires appear to be intact, unplug connector and proceed to step K. K. Measure the indicated sensors resistance value from the P6 connector. For this sensor, the resistance value should read 2.8 kΩ at 25°C (between pins 3 and 1 or between pins 3 and 2). L. If indicated temperature sensor does not meet these requirements proceed to step M. M. Replace cavity sensor. Ensure the cavity sensor is properly inserted and plugged into P6. Continue to step P. N. Replace humidity sensor. Ensure the humidity sensor is properly inserted and plugged into P4. Continue to step P. O. Replace microwave appliance manager. Ensure all connectors are properly placed and firmly connected. P. Replace all parts and panels before operating. Q. Plug in oven or reconnect power. Wait for 60 seconds. R. Enter into the Diagnostic Mode and press key "6" to scroll to the sensor display. Read the sensor reading for the three sensors, ensuring the cavity, humidity and internal sensors are reading correctly.</p>		
F5		NONE IDENTIFIED FOR MICROWAVE METHOD FOR DETERMINING FAILURE
<p>PROCEDURE: Before proceeding, press OFF, OFF, START to enter Diagnostic Mode. Using the main screen upon entering diagnostics open and close door on microwave. In the hours field, the second digit should show "0" when door is open and "1" when door is closed. If display shows a "0" when door is closed and does not transition to a "1", verify position of door switches and replace as necessary.</p>		
F5	E0 E1	DOOR AND LATCH SWITCH DO NOT AGREE DOOR LATCH NOT OPERATING.
<p>PROCEDURE: Before proceeding, press OFF, OFF, START to enter the Diagnostic mode.</p> <p>TO VERIFY DOOR SWITCH:</p> <p>A. While in diagnostics, open the oven door. The second digit on the clock display should toggle between "1" and "0" as the door opens and closes. When door is closed display should show "1", when the door is open display should show "0". If the second digit on the clock display did not toggle, go to step B. If the digit did not toggle after replacing the door switch, go to step D. If the digit did not toggle after replacing the door switch harness, go to step F.</p> <p>B. Unplug oven or disconnect power. C. Replace door switch. (If door switch is integral to the door/latch motor assembly, replace the entire door/latch motor assembly). Go to step H. D. Unplug oven or disconnect power. E. Check the integrity of the harness wires and connections between the appliance manager and the door/latch assembly. Ensure there are no shorted or pinched wires. If the wiring harness is pinched or damaged, replace the door switch harness. Go to step H. If wiring harness is good, go to step H.</p> <p>F. Unplug oven or disconnect power. G. Replace appliance manager. Go to step H. H. Replace all parts and panels before operating. I. Plug in oven or reconnect power. J. Press OFF, OFF, START to reenter Diagnostic mode. Repeat step A.</p>		

FAILURE (Leftmost 2 Clock Digits)	ERROR (Rightmost 2 Clock Digits)	MESSAGE/DESCRIPTION
		SUGGESTED CORRECTIVE ACTION PROCEDURE
TO VERIFY DOOR LATCH SWITCH/MOTOR ASSEMBLY:		
<p>A. While in diagnostics, press the CLEAN key within the first 120 seconds of power up to cycle the latch motor to the locked position. "1" should display in the first clock digit from the left when locked. Press the CLEAN key to cycle the latch motor to the unlocked position. The first clock digit should toggle to "0" when the door is unlocked.</p> <p>If the digit did not toggle, go to step B.</p> <p>If motor runs continuously, wait until motor reaches the unlocked position, open the door and press the OFF key. Go to step B.</p> <p>If motor did not run go to step H.</p> <p>If the digit did not toggle after replacing the door latch motor assembly, go to step D.</p> <p>If the digit did not toggle after replacing the door switch harness, go to step F.</p> <p>If the digit did toggle, door latch switch is operating correctly.</p> <p>B. Unplug oven or disconnect power.</p> <p>C. Replace door latch motor assembly. Go to step K.</p> <p>D. Unplug oven or disconnect power.</p> <p>E. Check the integrity of the harness wires and connections between the appliance manager and the door/latch assembly. Ensure there are no shorted or pinched wires.</p> <p>If the wiring harness is pinched or damaged, replace the door switch harness. Go to step H.</p> <p>If wiring harness is good, go to step H.</p> <p>F. Unplug oven or disconnect power.</p> <p>G. Replace appliance manager. Go to step H.</p> <p>H. Replace all parts and panels before operating.</p> <p>I. Plug in oven or reconnect power.</p> <p>J. Press OFF, OFF, START to reenter Diagnostic mode. Repeat step A.</p>		
F6 System	E0	LOST COMMUNICATIONS
<p>PROCEDURE: Before proceeding, press OFF, OFF, START to enter Diagnostic mode. Ensure AM software, UI software and EEPROM CHECKSUM versions appear on the lower text line. If AM software and EEPROM versions do not appear, UI and AM may not be communicating. Verify this for the lower oven UI and for the microwave (upper oven) UI. The lower oven UI will show the AM software version for the lower oven appliance manager, and the microwave UI will show the AM software and EEPROM versions for the microwave appliance manager.</p> <p>If the lower oven UI is not displaying the AM software version, go to UI IS NOT DISPLAYING AM SOFTWARE VERSION.</p> <p>If the upper oven UI is not displaying the AM software and EEPROM versions, go to UPPER OVEN UI IS NOT DISPLAYING THE AM SOFTWARE AND EEPROM VERSIONS.</p> <p>If lower oven UI and microwave UI are both displaying an error, go to LOWER OVEN UI AND MICROWAVE UI ARE BOTH DISPLAYING AN ERROR.</p> <p>UI IS NOT DISPLAYING AM SOFTWARE VERSION</p> <p>A. Unplug oven or disconnect power.</p> <p>B. Open the back panels and make sure the P6 and P2 connectors are fully inserted on the appliance manager and on the lower oven user interface board.</p> <ul style="list-style-type: none"> - If they are not plugged in, plug in connectors and go to step F. - If they are plugged in, go to step C. <p>C. Visually inspect all wires between P6 on the appliance manager and P2 on the lower user interface.</p> <ul style="list-style-type: none"> - Make sure wires are not cut or pinched. - If the wires appear to be intact, perform a continuity check between P6-1 of the appliance manager and P2-1 of the user interface board. Complete for P6-2(AM) to P2-2(UI), P6-4(AM) to P2-4(UI) and P6-5(AM) to P2-5(UI). All the measurements made should be less than 5 Ω. If any of these measurements exceeds 5 Ω, go to step E. <p>D. Replace the appliance manager. Ensure all connectors are properly inserted.</p> <p>E. Replace the wiring harness (signal). Ensure all connectors are properly inserted.</p> <p>F. Replace all parts and panels before operating.</p> <p>G. Plug in oven or reconnect power.</p> <p>H. Observe for longer than 1 minute to determine if error has been repaired.</p> <p>I. If error does not appear, initiate a bake cycle. Let the cycle run for at least 1 minute.</p> <ul style="list-style-type: none"> - If no error occurs, cancel the cycle, the problem has been repaired. - If error occurs again, restart the troubleshooting procedure at step A. <p>At step D, replace the lower oven user interface board if appliance manager has already been replaced.</p> <ul style="list-style-type: none"> - If both are replaced the problem has been repaired. 		

FAILURE (Leftmost 2 Clock Digits)	ERROR (Rightmost 2 Clock Digits)	MESSAGE/DESCRIPTION
		SUGGESTED CORRECTIVE ACTION PROCEDURE
UPPER OVEN UI IS NOT DISPLAYING THE AM SOFTWARE AND EEPROM VERSIONS		
<p>A. Unplug oven or disconnect power.</p> <p>B. Open the back panels and make sure the P2 and U3 connectors are fully inserted on the microwave user interface and the wide interface board. Make sure the P1 connector on the wide interface board and the P10 connector on the microwave oven appliance manager are inserted.</p> <ul style="list-style-type: none"> - If the P2 (mwo UI) and U3 (wide interface board) are plugged in, go to step C. - If the P2 (mwo UI) to U3 (wide interface board) connectors are not connected, plug in the connectors and proceed to step F. <p>If the P1 (wide interface board) to P10 (microwave appliance manager) connectors are not connected, plug in the connectors and go to step F.</p> <p>If the P1 (wide interface board) to P10 (microwave appliance manager) are plugged in, go to step D.</p> <p>C. Visually inspect all wires between P2 on the microwave user interface and U3 on the wide interface board. Make sure the wires are not cut or pinched. If the wires appear to be intact, perform a continuity check between P2-1 and U3-1 of the microwave user interface (mwo UI) and the wide interface board. Complete for P2-2 (mwo UI) to U3-2 (wide interface board), P2-4 (mwo UI) to U3-4 (wide interface board), and P2-5 (mwo UI) to U3-5 (wide interface board). All the measurements should be less than 5 Ω.</p> <ul style="list-style-type: none"> - If any of these measurements exceeds 5 Ω, replace the wiring harness (signal). Ensure all connectors are properly inserted and go to step H. - If the measurements are less than 5 Ω, reconnect P2 and go to step D. <p>D. Visually inspect all wires between P1 on the wide interface board and P10 on the microwave appliance manager. Make sure the wires are not cut or pinched. If the wires appear to be intact, perform a continuity check between P1-1 on the wide interface board to P10-1 on the microwave appliance manager, continuing for P1-2 (wide interface board) to P10-2 (microwave appliance manager), P1-3 to P10-3, P1-4 to P10-4, P1-5 to P10-5 and finally P1-6 to P10-6. All the measurements should be less than 5 Ω.</p> <ul style="list-style-type: none"> - If any of these measurements exceeds 5 Ω, go to step F. - If the measurements are less than 5 Ω, reconnect P1 and go to step E. <p>E. Replace the wide interface board. Ensure all connectors are properly inserted. Go to step H. If the wide interface board has already been replaced and the error has not been corrected, proceed to step G.</p> <p>F. Replace wiring harness (between P1 and P10) and proceed to step H.</p> <p>G. Replace the microwave appliance manager. Ensure all connectors are properly inserted. Go to step H.</p> <p>H. Replace all parts and panels before operating.</p> <p>I. Plug in oven or reconnect power.</p> <p>J. Observe for longer than one minute to determine if error has been repaired.</p> <p>K. If error does not appear, initiate a microwave cycle. Let the cycle run for at least 1 minute.</p> <ul style="list-style-type: none"> - If no error occurs, cancel the cycle, the problem has been repaired. - If error occurs, restart the troubleshooting procedure at step A. <p>At step E, replace the microwave user interface board in the wide interface board and/or microwave appliance manager have already been replaced.)</p> <ul style="list-style-type: none"> - If both are replaced the problem has been repaired. 		
LOWER OVEN UI AND MICROWAVE UI ARE BOTH DISPLAYING AN ERROR		
<p>A. Unplug oven or disconnect power.</p> <p>B. Open the back panels and make sure the P2 connector on the lower oven UI and the P2 connector on the microwave UI and fully inserted.</p> <ul style="list-style-type: none"> - If they are not, plug the connectors in and go to step F. - If they are plugged in, go to step C. <p>C. Visually inspect all the wires between P2 on the lower oven UI and P2 on the microwave user interface. Make sure the wires are not cut or pinched. If the wires appear to be intact, perform a continuity check between P2-1 of the lower oven UI and P2-1 of the user interface board. Complete for P2-2 (lower oven UI) to P2-2 (microwave UI), P2-4 (lower oven UI) to P2-4 (microwave UI) and P2-5 (lower oven UI) to P2-5(UI). All the measurements made should be less than 5 Ω.</p> <ul style="list-style-type: none"> - If any of these measurements exceeds 5 Ω, go to step E. - If any measurements are less than 5 Ω, reconnect P2 and go to step D. <p>D. Replace the lower oven UI. Ensure all connectors are properly inserted. Go to step F.</p> <p>E. Replace the wiring harness (signal) and proceed to step F.</p> <p>F. Replace all parts and panels before operating.</p> <p>G. Plug in oven or reconnect power.</p> <p>H. Observe for longer than 1 minute to determine if error has been repaired.</p> <p>I. If error does not appear, initiate a bake cycle. Let the cycle run for at least 1 minute.</p> <ul style="list-style-type: none"> - If no error occurs, cancel the cycle, the problem has been repaired. - If error occurs again, restart the troubleshooting procedure at step A. <p>(Except in step D, replace microwave user interface board if lower oven UI has already been replaced.)</p>		

FAILURE (Leftmost 2 Clock Digits)	ERROR (Rightmost 2 Clock Digits)	MESSAGE/DESCRIPTION
		SUGGESTED CORRECTIVE ACTION PROCEDURE
F6	E1 E2	COOK oven OVER TEMPERATURE CLEAN oven OVER TEMPERATURE
<p>PROCEDURE: Before proceeding, press OFF, OFF, START to enter the Diagnostic mode.</p> <p>A. If oven is off, turn oven on and inspect all of the elements, convect ring, bake and broil. Visually inspect all elements to ensure they are not operating.</p> <p>B. Unplug oven or disconnect power. Wait 10 seconds.</p> <p>C. Enter into Diagnostics following steps 1 through 3 on from page 6-2.</p> <p>D. Press the BAKE key to cycle the bake relay on and off as long as Diagnostics mode is within the first 120 seconds of power up.</p> <p>E. If the bake relay does not cycle, proceed to step F.</p> <p>F. Unplug oven or disconnect power for 30 seconds.</p> <p>G. Plug in oven or reconnect power.</p> <p>H. Enter into Diagnostics by pressing OFF, OFF, START. Press the BAKE key and cycle relay on and off.</p> <p style="padding-left: 20px;">If the bake relay does not cycle on and off, go to step O.</p> <p style="padding-left: 20px;">If the element does not cycle with the relay, go to step M.</p> <p style="padding-left: 20px;">If the element does cycle on and off, go to step I.</p> <p>I. Press the BROIL key, while in Diagnostics mode, to cycle the broil relays. Press BROIL key one time for outer broil element. Ensure outer broil relay energizes by inspecting the outer broil element. Press BROIL key again for inner broil element. Ensure inner broil relay energizes by inspecting the inner broil element.</p> <p style="padding-left: 20px;">If broil relay does not turn on and off, go to step O.</p> <p style="padding-left: 20px;">If the element does not cycle with the relay, go to step M.</p> <p style="padding-left: 20px;">If the element does cycle on and off, go to step J.</p> <p>J. Press the CONVECT key, while in Diagnostics mode, to cycle the convect relay on and off.</p> <p>K. If the convect relay does not turn on and off, go to step O.</p> <p>L. If the element does not cycle with the relay, go to step M.</p> <p>M. Unplug oven or disconnect power.</p> <p>N. Check integrity of all harness wires and connections between the appliance manager and the electrical elements. Ensure all wiring and connections between the appliance manager and elements, and the appliance manager and user interface are intact and properly seated and that no wires are shorted or damaged.</p> <p>O. Unplug oven or disconnect power.</p> <p>P. Replace the appliance manager. Go to step S.</p> <p>Q. Replace user interface board. Go to step S.</p> <p>R. Replace the harness.</p> <p>S. Replace all parts and panels before operating.</p> <p>T. Plug in oven or reconnect power.</p> <p>U. Verify operation is normal. Press OFF, OFF, START to reenter Diagnostic mode and complete checks.</p>		
F6	E3	MINI OVEN/WARM DRAWER OVER TEMPERATURE
<p>PROCEDURE: Oven is not equipped with this feature. If error occurs, before proceeding press OFF, OFF, START enter into Diagnostics mode, then replace user interface with correct control associated with this product.</p>		

FAILURE (Leftmost 2 Clock Digits)	ERROR (Rightmost 2 Clock Digits)	MESSAGE/DESCRIPTION
		SUGGESTED CORRECTIVE ACTION PROCEDURE
F6	E4	USER INTERFACE/ APPLIANCE MANAGER MISMATCH
<p>PROCEDURE: Before proceeding, press OFF, OFF, START to enter the Diagnostic mode.</p> <p>A. Unplug oven or disconnect power. Wait for 10 seconds.</p> <p>B. Plug in oven or reconnect power.</p> <p>C. Enter into Diagnostics mode by pressing OFF, OFF, START.</p> <p>D. Press BAKE. Ensure bake relay energizes by inspecting bake element.</p> <p>E. Press BROIL one time for outer broil element. Ensure outer broil relay energizes by inspecting the outer broil element.</p> <p>F. Press BROIL again for inner broil element. Ensure inner broil relay energizes by inspecting the inner broil element.</p> <p>G. Press SELF CLEAN to drive door latch to lock door. Press again to reset the door latch to normal state.</p> <p>H. Press COOK to activate the low speed cooling fan. Press again for high speed.</p> <p>I. If all functions are working, the AM and UI are properly working.</p> <p>J. Exit Diagnostics by pressing OFF.</p> <p>K. Press BAKE and ensure that bake relay energizes and the control enters the bake preheat. Wait up to 60 seconds to ensure error has been resolved. If error returns, proceed to step L.</p> <p>L. Unplug oven or disconnect power.</p> <p>M. Remove covers for access to oven controls.</p> <p>N. Replace the appliance manager. Ensure all connections are properly seated. Go to step O.</p> <p>O. Replace all parts and panels before operating.</p> <p>P. Plug in oven or reconnect power.</p> <p>Q. Press BAKE and ensure the bake relay energizes and the control enters into bake/preheat. Wait up to 60 seconds to ensure error has been resolved. If error returns, go to step R.</p> <p>R. Replace the user interface. Ensure all connections are properly seated. Go to step S.</p> <p>S. Replace all parts and panels before operating.</p> <p>T. Plug in oven or reconnect power.</p> <p>U. Press BAKE and ensure the bake relay energizes and the control enters into bake/preheat. Wait up to 60 seconds to ensure error has been resolved.</p>		
F6	E5	NO CAVITY SIZE COMMAND
<p>PROCEDURE: Before proceeding, press OFF, OFF, START to enter Diagnostics mode. Control should immediately power up in cavity size select mode. Using key #6 (down) and key #3 (up) scroll through to locate the corresponding cavity size. Once located, press the start key to accept the proper cavity size for the unit being programmed. Control should reinitialize to cavity size selected. If error returns at least 60 seconds after cavity size has been set, go to step A.</p> <p>A. Unplug oven or disconnect power. Wait 10 seconds.</p> <p>B. Plug in oven or reconnect power.</p> <p>C. Enter into Diagnostics mode by pressing OFF, OFF, START. Press #6 (down) once main diagnostics screen appears. Screen should identify cavity size for unit being programmed. If this is incorrectly shown, press CLOCK to edit current programmed size. Press #6 (down) to locate the proper cavity size. Once located, press START to accept the new cavity size. Control will reset and initialize the new cavity size programmed. Wait for 60 seconds to ensure error has been corrected.</p> <p style="padding-left: 20px;">If error is corrected, replace all parts and panels before operating.</p> <p style="padding-left: 20px;">If error returns, proceed to step D.</p> <p>D. Unplug oven or disconnect power.</p> <p>E. Replace user interface oven control ensuring all connections are properly seated and go to step F.</p> <p>F. Replace all parts and panels before operating.</p> <p>G. Plug in oven or reconnect power.</p> <p>H. Control may power up in cavity size select mode. Set cavity size as outlined in step C by locating proper cavity size and pressing START once located.</p> <p>I. Wait for at least 60 seconds to ensure error has been corrected.</p>		

FAHRENHEIT (° F) TO CELSIUS (° C) CONVERSION

The temperature is preset in Fahrenheit, however it can be changed to Celsius.

To Change: Press OPTIONS and then “1” to toggle temperature between Fahrenheit and Celsius settings.

When in Fahrenheit, “°F” follows the oven temperature.

When in Celsius, “°C” follows the oven temperature.

ADJUST OVEN TEMPERATURE CALIBRATION

1. Press OPTIONS and then “6” to set the calibration.
2. On double oven only, press UPPER OVEN or LOWER OVEN to select oven.
Each oven calibration can be independently set.
3. Press “3” to increase and “6” to decrease the temperature.
4. Press START to end calibration.

PROGRAMMING THE CAVITY SIZE

- A. Unplug oven or disconnect power.
- B. Wait 10 (ten) seconds, plug in oven or reconnect power.
- C. Enter Diagnostics mode by pressing OFF, OFF, START.
- D. Press key #6 to show cavity size select screen.
- E. To edit press CLOCK key.
- F. Scroll through cavity sizes by pressing key #6 until size required is displayed.
- G. Once correct size is displayed, press the START key to accept modification.

KEYPADS

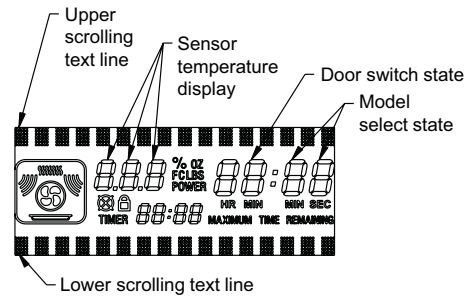
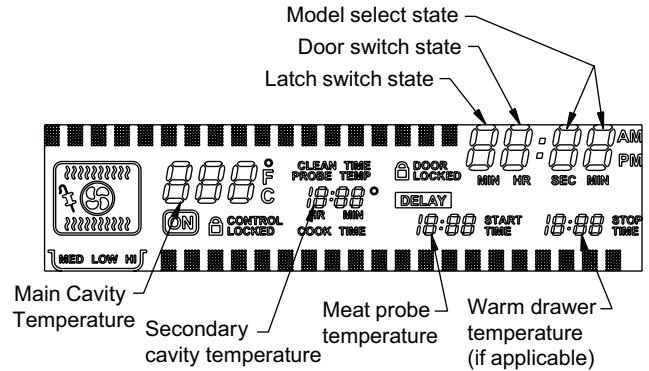

Model Select State	Description
02	27" Combo Microwave Upper/ Thermal Convection Lower
01	30" Combo Oven Microwave Upper/Thermal Convection Lower

MW OVEN POWER OUTPUT TEST

The power output of the magnetron can be measured by the following tap water temperature rise test.

NOTES:

- Be sure oven cavity is clean and cool (not used recently).
 - The magnetron output will be lower with lower line voltages.
1. Fill a glass beaker with 10 oz. (300mL) of tap water. Stir the water with a thermometer (digital recommended) and record the temperature. This starting temperature of the water should be between 50°F and 75°F (10°C and 24°C).
 2. Place the beaker and water in the center of the microwave oven. Operate on HIGH power level for 30 seconds.
 3. When the microwave oven is finished, stir the thermometer through the water and record the temperature.
 4. Subtract the cold water temperature from the warm water temperature to get the temperature rise. Normal range is as shown in the following table.

Voltage (VAC under load)	Temperature Rise
120V	20-27°F (11-15°C)
108V	18-27°F (10-15°C)

RELAY LOGIC - MICROWAVE OVEN

SUPERBA	MAGNETRON	GRILL	CONV. RING	CONV. FAN	COOLING FAN	TURNTABLE	LAMP
MICROWAVES FULL PWR	X	O	O	O	X	X	X
MICROWAVES VAR. PWR	X	O	O	O	X	X	X
CUSTOM REHEAT	X	O	O	O	X	X	X
CUSTOM DEFROST	X	O	O	O	X	X	X
SOFTEN/MELT	X	O	O	O	X	X	X
POPCORN	X	O	O	O	X	X	X
STEAM	X	O	O	O	X	X	X
CRISP	X	+	O	O	X	X	X
EASY CONVECT	O	+	+	X	X	X	X
COOL DOWN	O	O	O	O	X	O	O
OFF (DOOR CLOSED)	O	O	O	O	O	O	O
DOOR OPEN (COOL DOWN)	O	O	O	O	X	O	X
DOOR OPEN	O	O	O	O	O	O	X

RELAY LOGIC - LOWER OVEN

MODES	RELAYS	BAKE	IN BROIL	OUT BROIL	CONV ELEM	CONV FAN	DLB RELAY	OVEN LT	BLOWER
OFF	O	O	O	O	O	O	⊗	⊗	
BAKE PRE-B	X	+	X	O	O	X	⊗	L	
BAKE PRE-A	X	+	+	O	O	X	⊗	L	
BAKE SS	+	+	+	O	O	X	⊗	L	
CBAKE PRE-B	X	+	+	O	X	X	⊗	L	
CBAKE PRE-A	+	O	+	X	X	X	⊗	L	
CBAKE SS	+	O	+	X	X	X	⊗	L	
FBROIL PRE-B	O	X	X	O	O	X	⊗	L	
FBROIL PRE-A	O	X	X	O	O	X	⊗	L	
FBROIL SS	O	+	+	O	O	X	⊗	L	
INBROIL PRE-B	O	X	O	O	O	X	⊗	L	
INBROIL PRE-A	O	X	O	O	O	X	⊗	L	
INBROIL SS	O	+	O	O	O	X	⊗	L	
CBROIL PRE-B	O	X	X	O	X	X	⊗	L	
CBROIL PRE-A	O	X	X	O	X	X	⊗	L	
CBROIL SS	O	+	+	O	X	X	⊗	L	
CROAST PRE-B	X	+	+	O	X	X	⊗	L	
CROAST PRE-A	X	+	+	O	X	X	⊗	L	
CROAST SS	+	+	+	O	X	X	⊗	L	
BPROOF PRE-B	+	O	O	O	O	X	⊗	L	
BPROOF PRE-A	+	O	O	O	O	X	⊗	L	
BPROOF SS	+	O	O	O	O	X	⊗	L	
DEHYDRATE PRE-B	+	+	+	O	X	X	⊗	L	
DEHYDRATE PRE-A	O	O	O	+	X	X	⊗	L	
DEHYDRATE SS	O	O	O	+	X	X	⊗	L	
CLEAN	+	+	+	O	O	X	O	H	

RELAY LOGIC KEY

- O - OFF
- X - ON
- +
- ⊗ - ON OR OFF
- L - ON (LOW SPEED)
- H - ON (HIGH SPEED)

WIRING DIAGRAM & STRIP CIRCUITS

WIRING DIAGRAM

SYMBOLS

GROUND (CHASSIS)	RELAY COIL	THERMAL CUTOFF (NON-RESETTABLE)
PLUG WITH FEMALE CONNECTOR	RELAY CONTACTS	THERMAL CUTOFF (MANUALLY RESETTABLE)
RECEPTACLE WITH MALE CONNECTOR	HEATING ELEMENT	RESISTOR
LIGHT	ENCLOSED THERMISTOR	THERMOACTUATOR
AC DRIVE MOTOR	OPERATED BY DOOR	THERMOSTAT

NOTES:

- When replacing the electronic control, be sure to program the cavity size. See "Programming the Cavity Size" on page 6-7.
- Dots indicate connections or splices.
- Circuit shown in STANDBY/OFF mode with oven door closed.

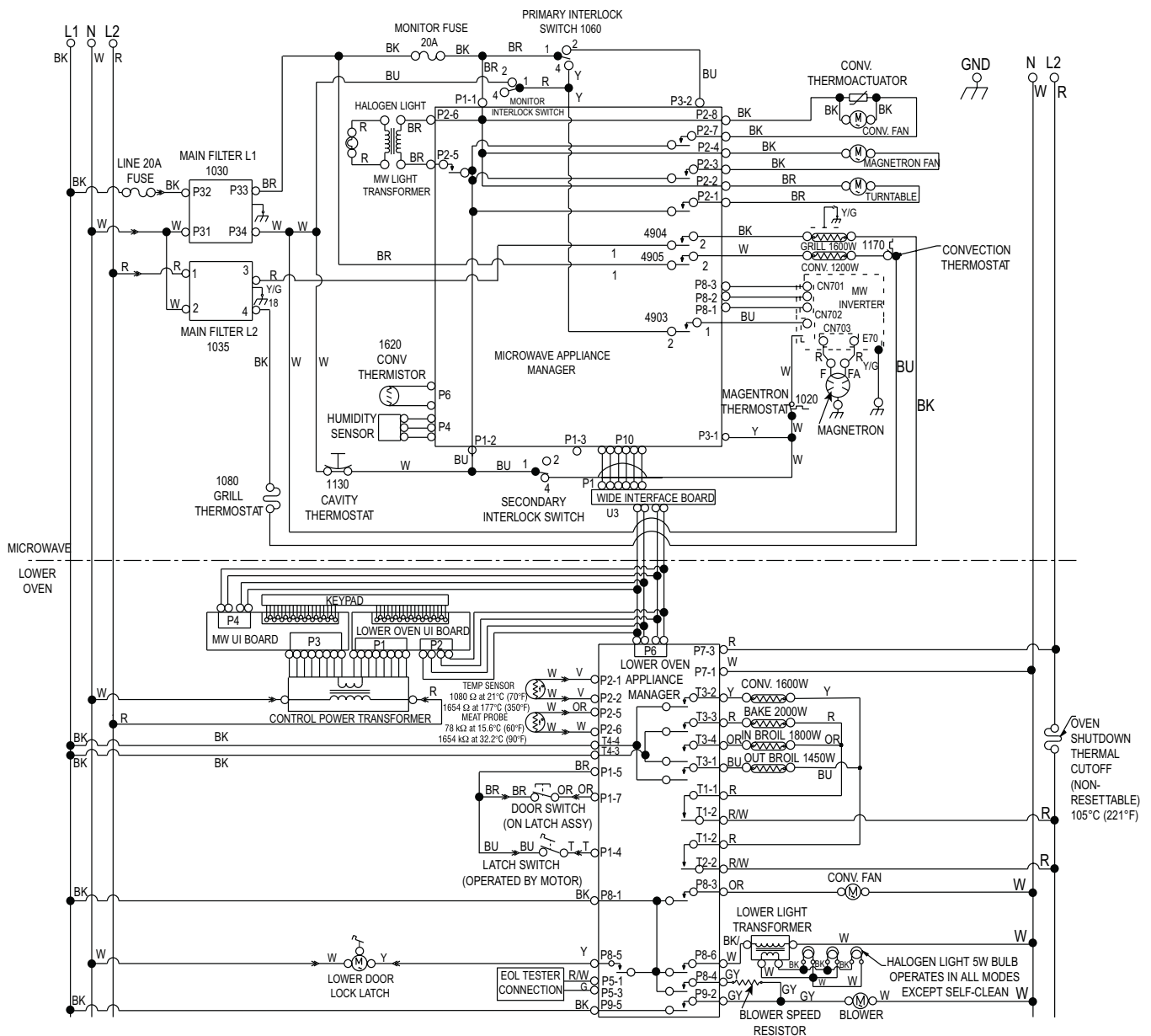

STRIP CIRCUITS

The following individual circuits are for use in diagnosis, and are shown in the ON position. Do not continue with the diagnosis of the appliance if a fuse is blown, a circuit breaker is tripped, or if there is less than a 240 volt power supply at the wall outlet.

BAKE PREHEAT B - BAKE PREHEAT A - BAKE SS

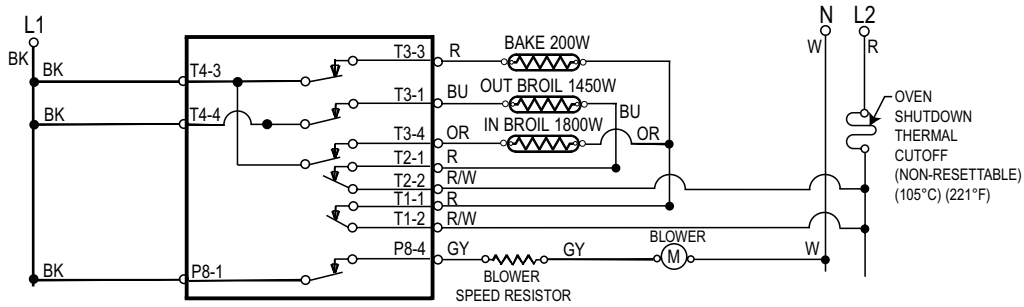

INNER BROIL PREHEAT B - INNER BROIL PREHEAT A - INNER BROIL SS

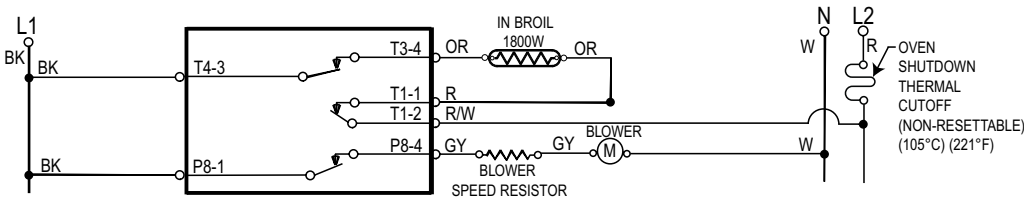

FULL BROIL PREHEAT B - FULL BROIL PREHEAT A - FULL BROIL SS

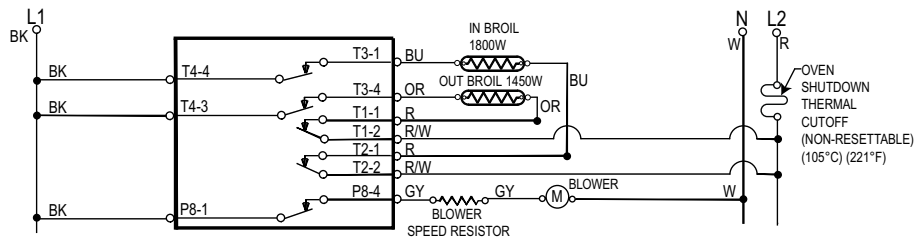

CONVECT BROIL PREHEAT B - CONVECT BROIL PREHEAT A - CONVECT BROIL SS (CONVECTION MODELS ONLY)

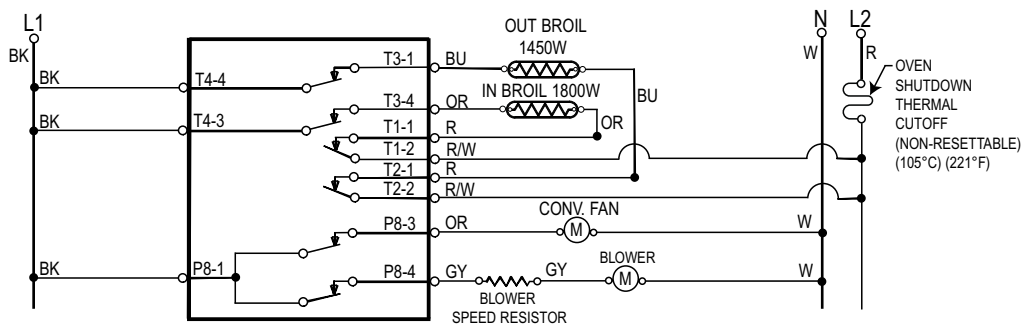

BREAD PROOF PREHEAT B - BREAD PROOF PREHEAT A - BREAD PROOF SS

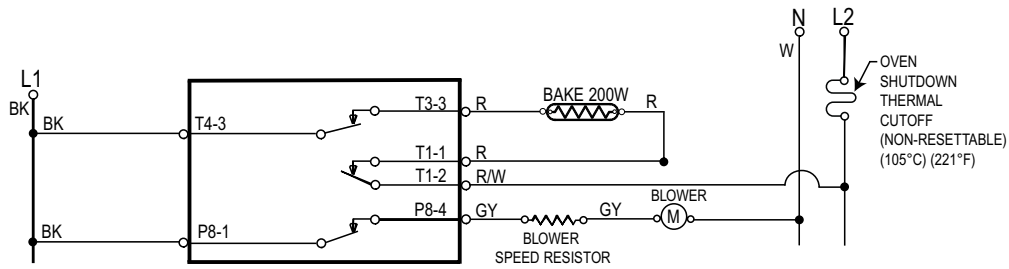

CONVECT BAKE PREHEAT A - CONVECT BAKE SS

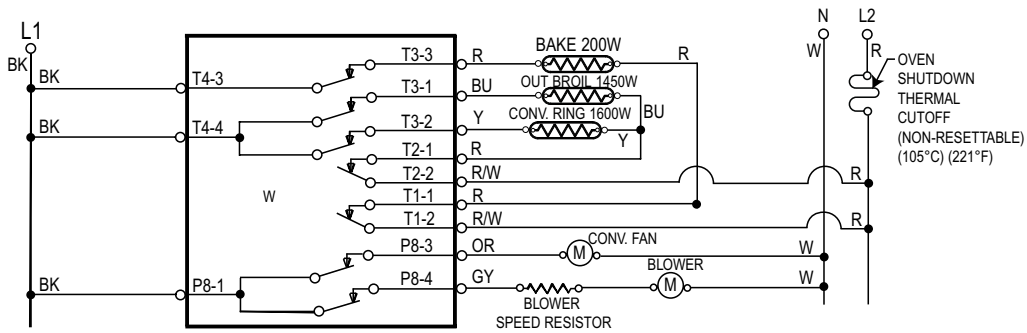

CONVECT BAKE PREHEAT B - CONVECT ROAST PREHEAT B - CONVECT ROAST PREHEAT A - CONVECT ROAST SS - DEHYDRATE PREHEAT B (CONVECTION MODELS ONLY)

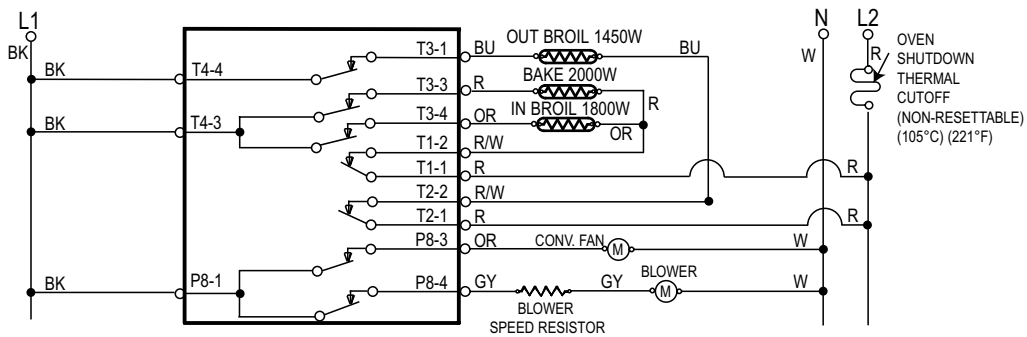

DEHYDRATE PREHEAT SS - DEHYDRATE PREHEAT A (CONVECTION MODELS ONLY)

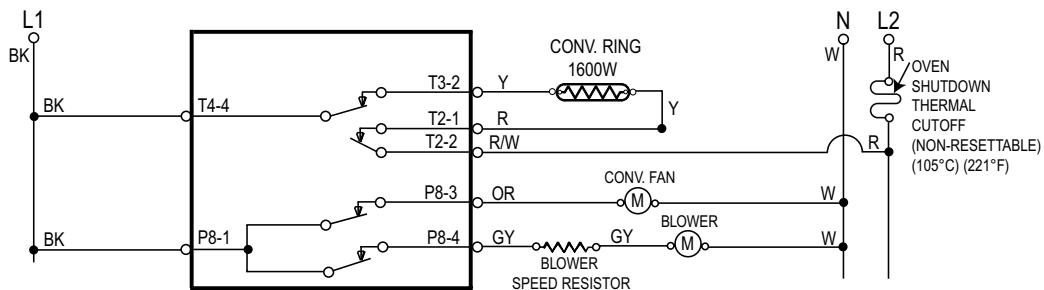

CLEAN

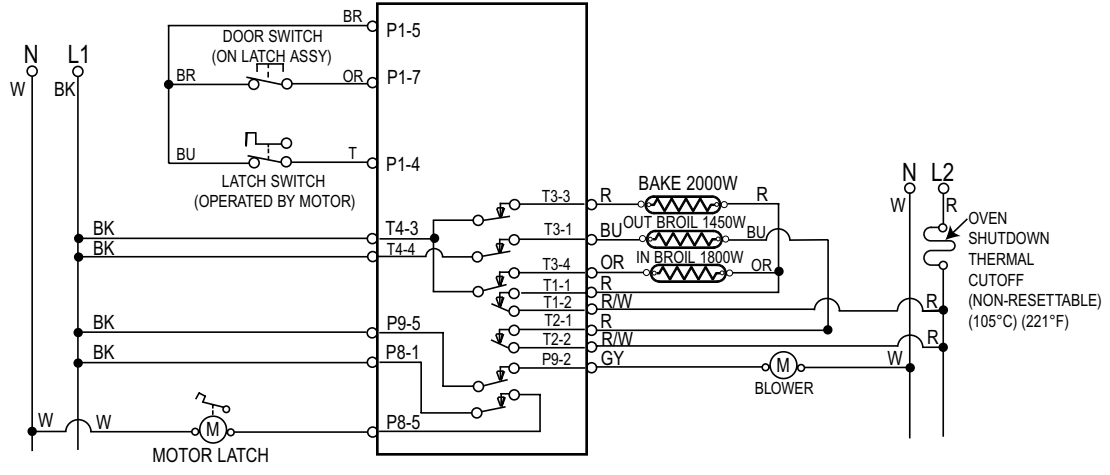

MWO FULL POWER - MWO VARIABLE POWER - MWO STEAM

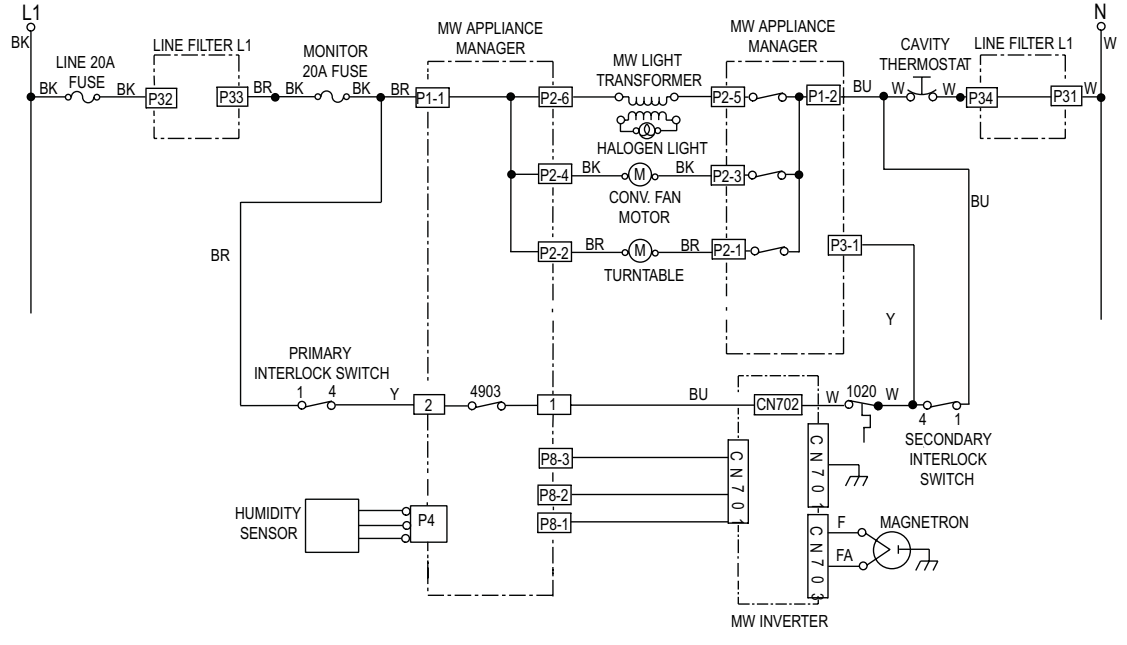

MWO CRISP

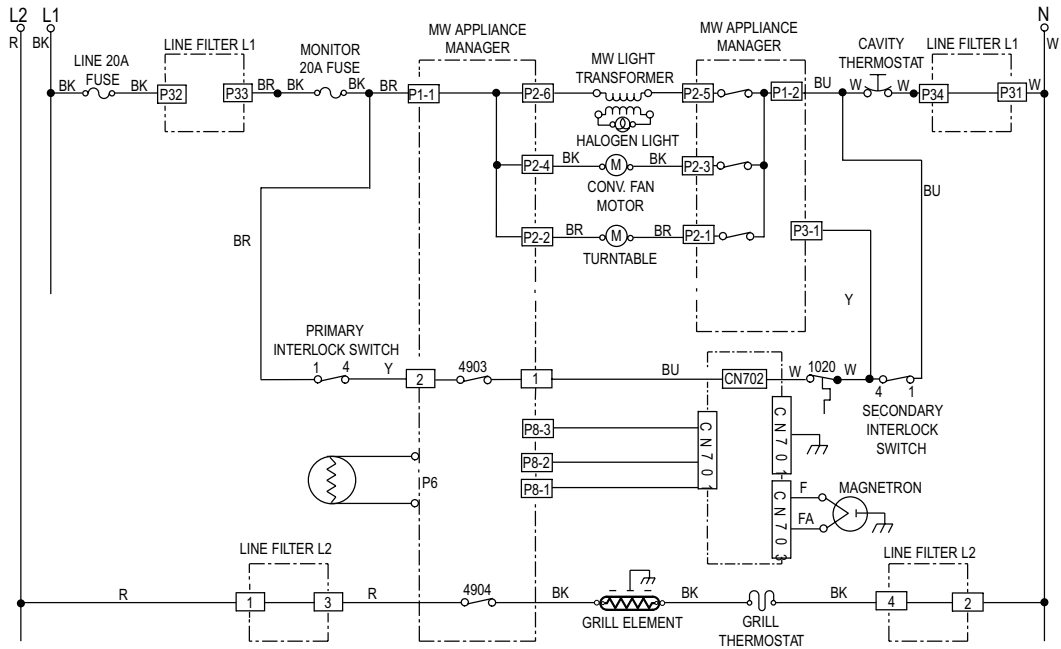

MWO EASY CONVECT

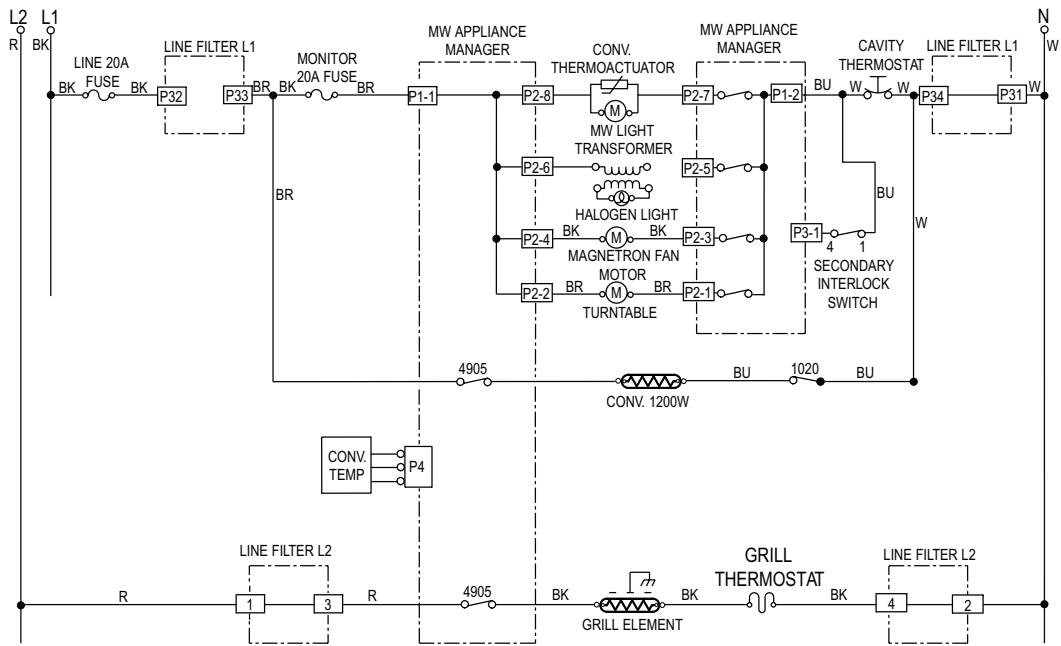

— NOTES —

PRODUCT SPECIFICATIONS AND WARRANTY INFORMATION SOURCES

IN THE UNITED STATES:

FOR PRODUCT SPECIFICATIONS AND WARRANTY INFORMATION CALL:

FOR WHIRLPOOL PRODUCTS: 1-800-253-1301

FOR KITCHENAID PRODUCTS: 1-800-422-1230

FOR ROPER PRODUCTS: 1-800-447-6737

FOR TECHNICAL ASSISTANCE WHILE AT THE CUSTOMER'S HOME CALL:

THE TECHNICAL ASSISTANCE LINE: 1-800-832-7174

**HAVE YOUR STORE NUMBER READY TO IDENTIFY YOU AS AN
AUTHORIZED IN-HOME SERVICE PROFESSIONAL**

FOR LITERATURE ORDERS:

PHONE: 1-800-851-4605

FOR TECHNICAL INFORMATION AND SERVICE POINTERS:

www.servicematters.com

IN CANADA:

FOR PRODUCT SPECIFICATIONS AND WARRANTY INFORMATION CALL:

1-800-461-5681

FOR TECHNICAL ASSISTANCE WHILE AT THE CUSTOMER'S HOME CALL:

THE TECHNICAL ASSISTANCE LINE: 1-800-832-7174

**HAVE YOUR STORE NUMBER READY TO IDENTIFY YOU AS AN
AUTHORIZED IN-HOME SERVICE PROFESSIONAL**

KitchenAid®
FOR THE WAY IT'S MADE.®