

KitchenAid

TECHNICAL EDUCATION

BUILT-IN MICROWAVE OVEN



FORWARD

This Job Aid, "KitchenAid Built-In Microwave Oven," (Part No. 4317283), provides the technician with information on the installation and service of the KitchenAid Built-In Microwave Oven. It is to be used as a training Job Aid and Service Manual. For specific information on the model being serviced, refer to the "Use and Care Guide," or "Tech Sheet" provided with the microwave oven.

The Wiring Diagrams and Strip Circuits used in this Job Aid are typical and should be used for training purposes only. Always use the Wiring Diagram supplied with the product when servicing the unit.

GOALS AND OBJECTIVES

The goal of this Job Aid is to provide detailed information that will enable the service technician to properly diagnose malfunctions and repair the Built-In Microwave Oven.

The objectives of this Job Aid are to:

- Understand and follow proper safety precautions.
- Successfully troubleshoot and diagnose malfunctions.
- Successfully perform necessary repairs.
- Successfully return the microwave oven to proper operational status.

WHIRLPOOL CORPORATION assumes no responsibility for any repair made on our products by anyone other than Authorized Factory Service Technicians.

Copyright 2000, Whirlpool Corporation, Benton Harbor, MI 49022

Table of Contents

	Page
SPECIFICATIONS	1-1
COMPONENT ACCESS	2-1
Oven Cabinet Component Locations	2-1
Microwave Oven Component Locations	2-1
Removing The Microwave Oven Assembly	2-2
Removing The Oven Control & Display Boards And The Touch Panel Assembly	2-3
Removing The Low Voltage Transformer, The Light Power Supply, & Suppressor Board	2-5
Removing The Blower Motor Assembly	2-7
Removing The Microwave Oven From The Oven Cabinet	2-8
Removing The Primary, Secondary, & Monitor Interlock Switches And The Air Pressure Relief Valve	2-10
Removing The Grill Thermal Fuse And The Grill Element Assembly	2-12
Removing The Convection Temperature Sensor, The Halogen Lamp, And The Cavity Thermal Fuse	2-14
Removing The Convection Thermal Fuse, Convection Element, And Convection Fan Motor	2-16
Removing The Cooling Fan Motor & Air Vent Solenoid	2-18
Removing The Magnetron Thermal Fuse And The Magnetron	2-20
Removing The High Voltage Transformer	2-22
Removing The Line Fuse & Fuseholder, The High Voltage Rectifier, & High Voltage Capacitor	2-24
Removing The Turntable Motor	2-26
Removing The Oven Door Handle & Front Door Glass	2-27
Removing The Oven Door & The Inner Glass	2-28
COMPONENT TESTING	3-1
The Turntable & Cooling Fan Motors	3-1
The Low Voltage Transformer & Light Power Supply	3-2
The Blower & Convection Fan Motors	3-3
The Convection Temperature Sensor	3-4
The Cavity, Grill, Convection, & Magnetron Thermal Fuses	3-5
The Convection Element & Grill Element Assembly	3-6
The Line Fuse, High Voltage Rectifier, & High Voltage Capacitor	3-7
The Air Vent Solenoid & Interlock Switches	3-8
The High Voltage Transformer & Magnetron	3-9
Control Panel Resistor	3-10
DIAGNOSIS & TROUBLESHOOTING	4-1
Failure/Error Display Codes	4-1
Components That Can Be Tested At The Control Panel	4-1
Electronic Oven Control Pinouts	4-2
Microwave Oven Power Output Test	4-3
Microwave Oven Relay Logic	4-3
Troubleshooting Chart	4-4
WIRING DIAGRAMS & STRIP CIRCUITS	5-1
TECH TIPS	6-1

KITCHENAID MODEL & SERIAL NUMBER DESIGNATIONS

MODEL NUMBER

MODEL NUMBER		K	BM	C	14	7	H	WH	0
INTERNATIONAL SALES IND. OR MARKETING CHANNEL IF PRESENT									
PRODUCT GROUP K = KITCHENAID BRAND									
PRODUCT IDENTIFICATION BH = BUILT-IN HIGH-SPEED OVEN BM = BUILT-IN MICROWAVE CM = COUNTERTOP MICROWAVE HM = MICROWAVE HOOD									
MERCHANDISING SCHEME S = STANDARD C = MICRO-CONVECTION									
CAPACITY / SIZE / SERIES / CONFIGURATION 05 = 0.5 CU FT 08 = 0.8 CU FT 10 = 1.0 CU FT 13 = 1.3 CU FT 14 = 1.4 CU FT									
FEATURES 2 = PLUS FEATURES 5 = DELUXE FEATURES 6 = MICRO-CONVECTION 7 = MICRO-CONVECTION WITH SENSOR S = CARRY-IN WARRANTY (EFFECTIVE 02/96) X = IN-HOME WARRANTY (EFFECTIVE 02/96)									
YEAR OF INTRODUCTION H = 1999, J = 2000, K = 2001									
COLOR CODE WH = WHITE, BL = BLACK, SS = STAINLESS STEEL									
ENGINEERING CHANGE (0, 1, 2, ETC.)									

SERIAL NUMBER

SERIAL NUMBER	X	K	16	01004
MANUFACTURING SITE X = OXFORD				
YEAR OF PRODUCTION K = 2000, L = 2001, M = 2002				
WEEK OF PRODUCTION 16TH WEEK				
PRODUCT SEQUENCE NUMBER				

MODEL NUMBER

MODEL NUMBER		K	BH	C	17	9	J	WH	0
INTERNATIONAL SALES IND. OR MARKETING CHANNEL IF PRESENT									
PRODUCT GROUP K = KITCHENAID BRAND									
PRODUCT IDENTIFICATION BH = BUILT-IN HIGH-SPEED OVEN BM = BUILT-IN MICROWAVE CM = COUNTERTOP MICROWAVE HM = MICROWAVE HOOD									
MERCHANDISING SCHEME S = STANDARD C = MICRO-CONVECTION									
CAPACITY / SIZE / SERIES / CONFIGURATION 05 = 0.5 CU FT 08 = 0.8 CU FT 10 = 1.0 CU FT 13 = 1.3 CU FT 17 = 1.4 CU FT									
FEATURES 2 = PLUS FEATURES 5 = DELUXE FEATURES 6 = MICRO-CONVECTION 7 = MICRO-CONVECTION WITH SENSOR 9 = MULTIMODE-HI SPEED-CONVECTION S = CARRY-IN WARRANTY (EFFECTIVE 02/96) X = IN-HOME WARRANTY (EFFECTIVE 02/96)									
YEAR OF INTRODUCTION H = 1999, J = 2000, K = 2001									
COLOR CODE WH = WHITE, BL = BLACK, SS = STAINLESS STEEL									
ENGINEERING CHANGE (0, 1, 2, ETC.)									

SERIAL NUMBER

SERIAL NUMBER	X	K	16	01004
MANUFACTURING SITE X = OXFORD				
YEAR OF PRODUCTION K = 2000, L = 2001, M = 2002				
WEEK OF PRODUCTION 16TH WEEK				
PRODUCT SEQUENCE NUMBER				

MODEL & SERIAL NUMBER LABEL AND TECH SHEET LOCATIONS

The Model/Serial Number label and Tech Sheet locations are shown below.

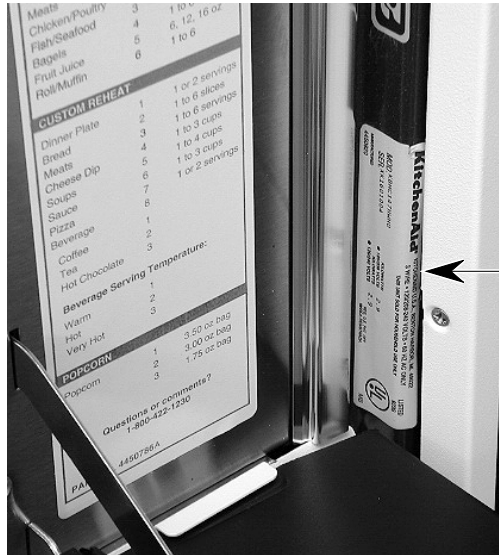

Model & Serial Number Location

Tech Sheet Location (Below Top Front Cover)

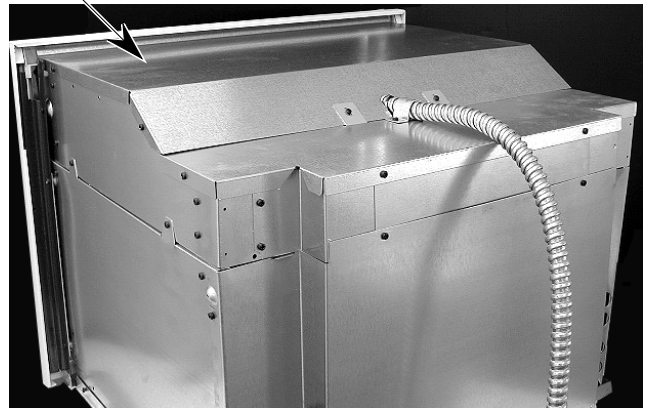

IMPORTANT SAFETY INFORMATION

Your safety and the safety of others is very important.

Important safety messages have been provided in this Job Aid. Always read and obey all safety messages.



This is the safety alert symbol.

This symbol alerts you to hazards that can kill or hurt you and others.

All safety messages will be preceded by the safety alert symbol and the word **“WARNING.”**

All safety messages will identify the hazard, tell you how to reduce the chance of injury, and tell you what can happen if the instructions are not followed.

Grounding Instructions

CORD CONNECTED

The microwave oven must be grounded. In the event of an electrical short circuit, grounding reduces the risk of electric shock by providing an escape wire for the electrical current. The microwave oven is equipped with a cord having a grounding wire with a grounding plug. The plug must be plugged into an outlet that is properly installed and grounded.



Improper use of the grounding plug can result in a risk of electric shock.

Consult a qualified electrician or serviceman if the grounding instructions are not completely understood, or if doubt exists as to whether the microwave oven is properly grounded. Do not use an extension cord. If the power supply cord is too short, have a qualified electrician or serviceman install an outlet near the microwave oven.

PERMANENTLY CONNECTED

The microwave oven must be connected to a grounded, metallic, permanent wiring system, or an equipment grounding conductor should be run with the circuit conductors and connected to the equipment grounding terminal, or lead, on the microwave oven.

Warning To Service Technicians

To avoid possible exposure to microwave radiation or energy, visually check the oven for damage to the door and door seal before operating any oven. Use a microwave survey meter to check the amount of leakage before servicing. In the event the R.F. leakage exceeds 4 mw/cm² at 5 cm, appropriate repair must be made before continuing to service the unit. Check interlock function by operating the door latch. The oven cook cycle should cut off before the door can be opened.

The door and latching assembly contains the radio frequency energy within the oven. The door is protected by three safety interlock switches. Do not attempt to defeat them.

UNDER NO CIRCUMSTANCES SHOULD YOU TRY TO OPERATE THE OVEN WITH THE DOOR OPEN.

- Proper operation of microwave ovens requires that the magnetron be properly assembled to the waveguide and cavity. Never operate the magnetron unless it is properly installed.
- Be sure the “RF” seal is not damaged and is assembled around the magnetron dome properly when installing the magnetron.
- Routine service safety procedures should be exercised at all times.
- Untrained personnel should not attempt service without a thorough review of test procedures and safety information contained in this Job Aid.

KitchenAid microwave ovens have a monitoring system designed to assure proper operation of the safety interlock systems.

The interlock monitor switch will immediately cause the oven fuse to blow if the door is opened and the primary door interlock switch and/or the secondary interlock switch contacts fail in a closed position.

CAUTION: REPLACE BLOWN FUSE WITH 20 AMPERE CLASS H FUSE ONLY

Test the upper and lower door interlock switches, cook relay and interlock monitor switch (middle switch) for proper operation as described in the component test procedures, before replacing the blown oven fuse.

DO NOT ATTEMPT TO REPAIR STICKING CONTACTS OF ANY INTERLOCK SWITCH, SAFETY SWITCH OR COOK (LATCH) RELAY. THE COMPONENTS MUST BE REPLACED.

Any indication of sticking contacts during component tests requires replacement of that component to assure reliability of the safety interlock system.

IF THE FUSE IS BLOWN, THE MONITOR, PRIMARY, AND SECONDARY INTERLOCK SWITCHES MUST BE REPLACED. BE SURE THEY ARE PROPERLY CONNECTED.

Precautions To Be Observed Before And During Servicing To Avoid Possible Exposure To Excessive Microwave Energy

1. Do not operate or allow the oven to be operated with the door open.
2. Make the following safety checks on all ovens to be serviced before activating the magnetron or other microwave source and make repairs as necessary.
 - a) Interlock Operation
 - b) Proper Door Closing
 - c) Seal and Sealing Surfaces (Arcing, Wear and Other Damage)
 - d) Damage to or Loosening of Hinges and Latches
 - e) Evidence of Dropping or Abuse
3. Before turning on the microwave power for any service test or inspection within the microwave generating components, check the magnetron, wave guide or transmission line and cavity for proper alignment.
4. Any defective or misadjusted components in the interlock, monitor, door seal and microwave generation and transmission system shall be repaired by procedures described in the Job Aid for the specific microwave oven being serviced before the oven is released to the owner.
5. A microwave leakage check to verify compliance with Federal Performance Standards should be performed on each oven prior to release to the owner.
6. Do not attempt to operate the oven if the door glass is broken.

CAUTION

- High voltages are present during the cook cycle. Extreme caution should be observed at all times.
- Abrasive cleansers, steel-wool pads, gritty wash cloths, etc. can damage the control panel and the interior and exterior oven surfaces. Use a sponge with mild detergent or paper towels with spray glass cleaner. Apply spray glass cleaner to paper towel. Do not spray directly on oven.
- Before touching any oven component or wiring, always unplug the oven from its power source and discharge the capacitor by using a 20,000 ohm discharge resistor or use an insulated plastic handle screwdriver to short across the capacitor terminals.
- Check that the unit is grounded before troubleshooting. Be careful of the high voltage circuits. Discharge any static charge from your body by touching ground before handling any part of the circuitry on the control board. Electrostatic discharge may damage the control circuit.
- Do not touch oven components or wiring during operation. Attach meter leads with alligator clips when making operational tests.
- For continued protection against radiation emission, replace only with these types of switches: Primary (Interlock) Switch: SZM-V16-FA-63 or VP-533A-OF; Secondary (Interlock) Switch: SZM-V01-FA-32; Interlock (Monitor) Switch: SZM-VI6-FA-62 or VP-532A-OF; Oven Lamp Switch: SZM-V6-FA-31 or VP-331 A-OD.
- It is neither necessary nor advisable to attempt measurement of high voltage.
- Attaching the adaptor ground terminal to the wall receptacle cover screw does not ground the appliance unless the cover screw is metal and not insulated and the wall receptacle is grounded through the house wiring.

WARNING

- Disconnect the oven from electrical supply before servicing. Failure to do so could result in electrical shock or death.
- Improper use of the grounding plug can result in a risk of electrical shock. Do not, under any circumstance, cut or remove the third ground prong from the power cord plug.

Fire, Electrical Shock, Excessive Exposure to Microwave Energy, Personal Injury & Product Damage Hazard

- Do not block the rear air intake openings or exhaust vents. Allow a few inches of space at the back of the oven where intake openings and exhaust vents are located. Blocking the air intake openings and exhaust vents can cause damage to the oven and poor cooking results.

Electrostatic Discharge (ESD) Sensitive Electronics

ESD problems are present everywhere. ESD may damage or weaken the electronic control assembly. The new control assembly may appear to work well after repair is finished, but failure may occur at a later date due to ESD stress.

- Use an antistatic wrist strap. Connect wrist strap to green ground connection point or unpainted metal in the appliance, or touch your finger repeatedly to a green ground connection point or unpainted metal in the appliance.
- Before removing the part from its package, touch the antistatic bag to a green ground connection point or unpainted metal in the appliance.
- Avoid touching electronic parts or terminal contacts; handle electronic control assembly by the edges only.
- When repackaging failed electronic control assembly in antistatic bag, observe above instructions.

R.F. LEAKAGE TEST

EQUIPMENT

- Electromagnetic energy leakage monitor (NARDA 81 00B, HOLADAY H 1 501).
- 250 ml glass beaker.

TEST

On every service call, checks for microwave energy emission must be made according to the following manner.

1. Remove the cooking rack from the oven cavity, if the microwave oven is so equipped.
2. Place a 250 ML (8.0 oz.) glass of water in the center of the oven bottom.
3. Select "HIGH" cook power, turn the microwave oven on, and test for R.F. leakage at the following locations using the pattern shown below:
 - a) Around the cabinet at the front.
 - b) Around the door.
 - c) Across the console panel.
 - d) Horizontally across the door.
 - e) Vertically across the door.
 - f) Diagonally across the door.
 - g) Across the air vents.
 - h) Across the rear air vent.
 - i) All lockseams.
 - j) Weld at bottom.
 - k) Bottom plate.
 - l) Oven feet.
4. The scan speed is one inch per second.

When checking for R.F. leakage, use an approved R.F. measuring device to assure less than 4 mw/cm² emission at 5 cm distance with a maximum scan rate of 2.5 cm/second, in compliance with U.S. Government Department of Health, Education and Welfare 21 CFR1030, performance Standard for Microwave Ovens.

A properly operating door and seal assembly will normally register small emissions, but they must be no greater than 4 mw/cm² to allow for measurement uncertainty.

NOTE: Enter leakage readings in space BEFORE and AFTER on the service document.

All microwave ovens exceeding the emission level of 4 mw/cm² must be reported to Dept. of Service for microwave ovens immediately and the owner should be told not to use the microwave oven until it has been repaired completely.

If a microwave oven is found to operate with the door open, report to Dept. of Service, the manufacturer and CDRH* immediately. Also tell the owner not to use the oven.

The interlock monitor switch acts as the final safety switch protecting the customer from microwave radiation. If the interlock monitor switch operated to blow the fuse when the interlocks failed, you must replace all interlock switches with new ones, because the contacts of those interlock switches may be melted and welded together.

All repairs must be performed in such a manner that microwave energy emissions are minimal.

Address for CDRH is:

**Office of Compliance (HFZ-312) Center
for Devices and Radiological Health
1390 Piccard Drive
Rockville, Maryland 20850**

* CDRH: Center for Device and Radiological Health, Food and Drug Administration.

— NOTES —

SPECIFICATIONS

Model Number	KBMC140H	KBMC147H
Model Description	Built In Microwave	Built In Microwave
Size-Configuration	30"	27"
Feature Level/Series	Crisp Convection	Crisp Convection
Dimensions/Specifications		
Exterior Dimensions		
Overall Height (in)	20 1/2"	20 1/2"
Overall Width (in)	29 3/4"	26 3/4"
Cutout Height (in) (Measure Or Min/Max)	19 7/16"	19 7/16"
Cutout Width (in) (Measure Or Min/Max)	28 1/2"	25 1/2"
Cutout Depth (in) (Measure Or Min/Max)	23 1/4"	23 1/4"
Other Dimensions		
Conduit Size (in) (Length/Diameter)	57"; 1/2"	57"; 1/2"
Total Connected Load in kW		
240 Volts	3 kw	3 kw
208 Volts	3 kw	3 kw
Circuit Amps	20 AMP	20 AMP
Exterior		
Oven Control Type	Electronic	Electronic
Microwave Controls	VFD (Blue,Green,Red)	VFD (Blue,Green,Red)
Membrane Touch	Yes	Yes
Probe	No	No
Microwave Timer	Yes	Yes
Diagnostics	Yes	Yes
Error Indication	Yes	Yes
MW Power (Watts)	900 Watts	900 Watts
Off/Cancel	Yes	Yes
Programming Tone	Yes	Yes
Staged Cooking # Levels/Type	3 Level	3 Level
Start/Enter	Yes	Yes
Stoppable Turntable	No	No
Broil Element Output (Watts)	1200 Watts	1200 Watts
Broil Heat-Up Time	<1 minute	<1 minute
Crisp Turntable Performance # IEC Pts/Min for Release	3.5	3.5
Crisp Pan Size/Type	322 mm OD	322 mm OD
MW Cavity Volume (cu ft)	1.4	1.4
MW Cavity Material	Stainless	Stainless
Miscellaneous		
Product Literature		
Installation Instructions Part/Comment	4452615	4452615
Tech Sheet Part/Comment	4452613	4452613
Use & Care Guide Microwave Part/Comment	4452614	4452614
Other	Cooking Tips - 3191638	Cooking Tips - 3191638
Agency Approvals	UL & CSA	UL & CSA
Installation Hardware	Yes	Yes
Residential Use Only	Yes	Yes
Warranty		
Full (Months)	12	12
Extended		
Electronic Controls (Months)	60	60
Electrical Elements (Months)	60	60
Magnetron (Months)	60	60

Model Number	KBHC179J	KBHC109J
Release Info		
Colors	Black, White, Stainless, Biscuit	Black, White, Stainless, Biscuit
Model		
Model Description	Built-In High Speed	Built-In High Speed
Size-Configuration	27"	30"
Feature Level/Series	Crisp Convection	Crisp Convection
Dimensions/Specifications		
Exterior Dimensions		
Overall Height (in)	20 1/2"	20 1/2"
Overall Width (in)	26 3/4"	29 3/4"
Overall Depth Inc Hrdwr/Hndl (in)	25 1/8"	25 1/8"
Depth W/O Handle (in)	23 7/8"	23 7/8"
Other Dimensions		
Conduit Size (in) (Length/Diameter)	57"; 1/2"	57"; 1/2"
Weight		
Net Weight (lbs)	110	117
Total Connected Load in kW		
240 Volts	4.4 kw	4.4 kw
208 Volts	3.8 kw	3.8 kw
Circuit Amps	30 Amp	30 Amp
Probe	No	No
Microwave Timer	Yes	Yes
Diagnostics	Yes	Yes
Error Indication	Yes	Yes
MW Power (Watts)	900 Watts	900 Watts
Stoppable Turntable	No	No
Broil Element Type	Quartz	Quartz
Broil Element Output (Watts)	1200 Watts	1200 Watts
Broil Heat-Up Time	<1 minute	<1 minute
Interior		
MW Cavity Volume (cu ft)	1.4	1.4
MW Cavity Material	Porcelain Enamel Steel	Porcelain Enamel Steel
Other		
Agency Approvals	UL	UL
Residential Use Only	Yes	Yes
Warranty		
Full (Months)	12	12
Electronic Controls (Months)	60	60
Electrical Elements (Months)	60	60
Magnetron (Months)	60	60
Miscellaneous		
Installation Instructions	Yes	Yes
Installation Instructions Part	4452615	4452615
Tech Sheet Part	4452613	4452613
Use & Care Guide Microwave Part	4452614	4452614

COMPONENT ACCESS

This section instructs you on how to service each component inside the Model KBMC147H Built-In Microwave Oven. The components and their locations are shown below.

OVEN CABINET COMPONENT LOCATIONS

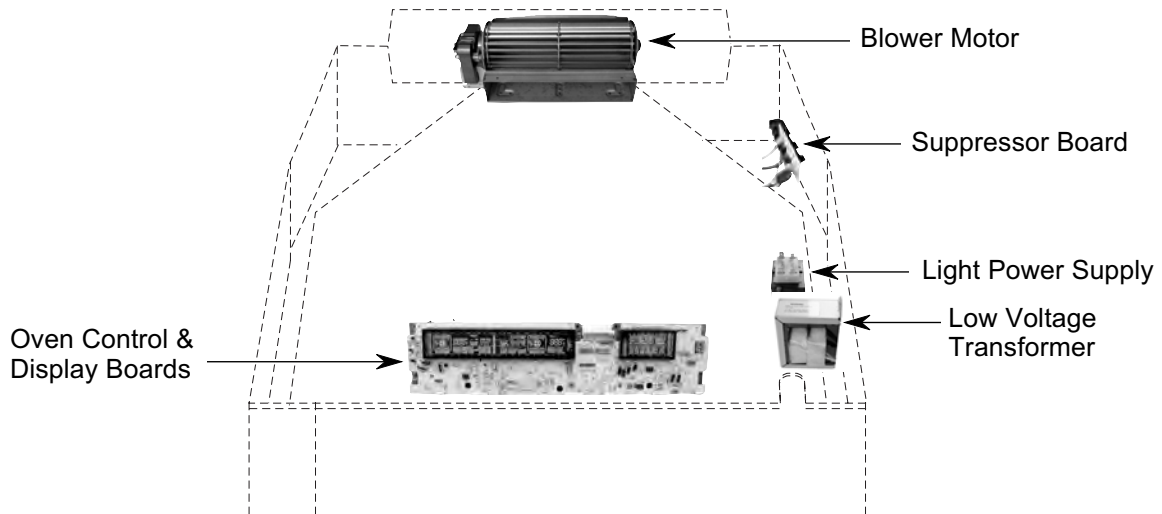

MICROWAVE OVEN COMPONENT LOCATIONS

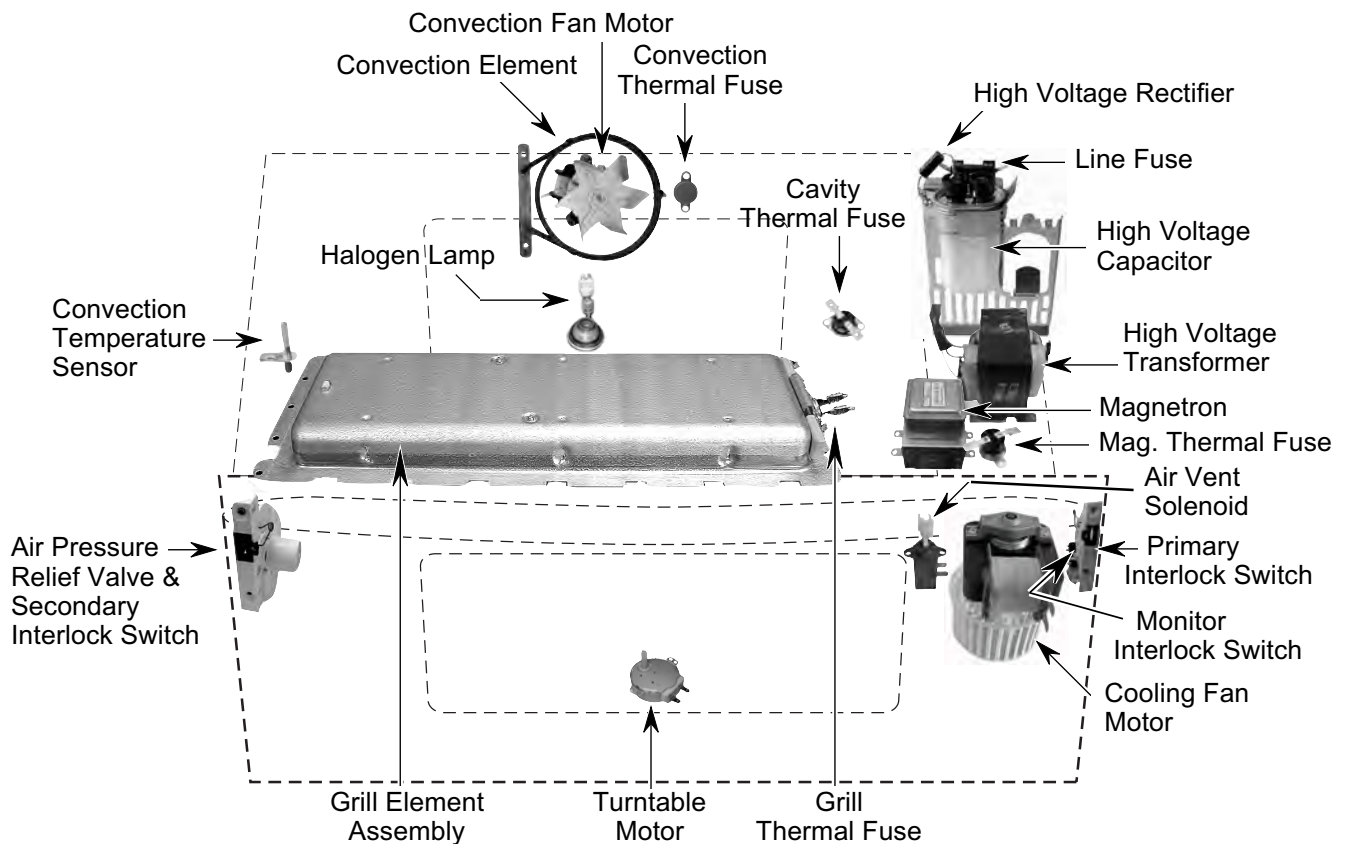

REMOVING THE MICROWAVE OVEN ASSEMBLY

! WARNING

Electrical Shock Hazard

Disconnect power before servicing.
 Replace all panels before operating.
 Failure to do so could result in death or electrical shock.

CAUTION: When you work on the microwave oven, be careful when handling the sheet metal parts. Sharp edges may be present, and you can cut yourself if you are not careful.

1. Disconnect the electrical power to the microwave oven.
2. Remove the glass turntable and roller assembly from inside the oven cavity.

Turntable &
 Roller Assembly

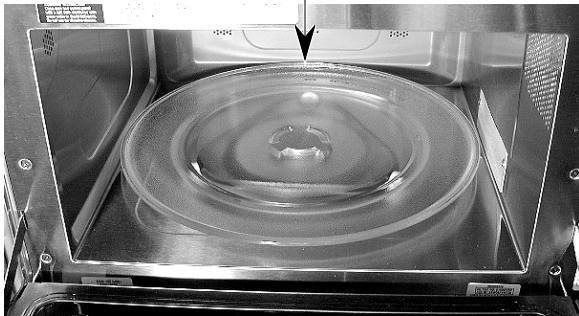

3. Completely open the microwave oven door.
4. Remove the screws from the side trim.

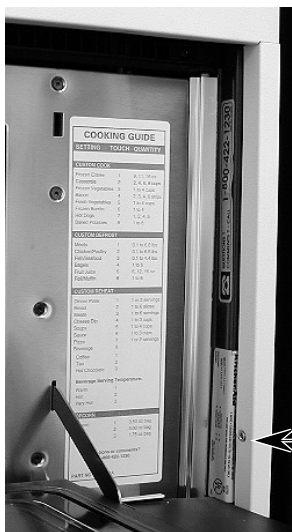

Side Trim Screw
 (1 On Each Side)

5. To remove the side trim, pull the bottom out approximately 2" and slide the top down to disengage it from the front panel.

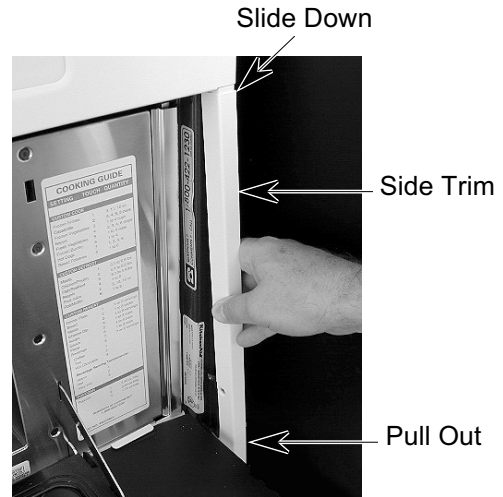

6. Remove the two cabinet mounting screws.

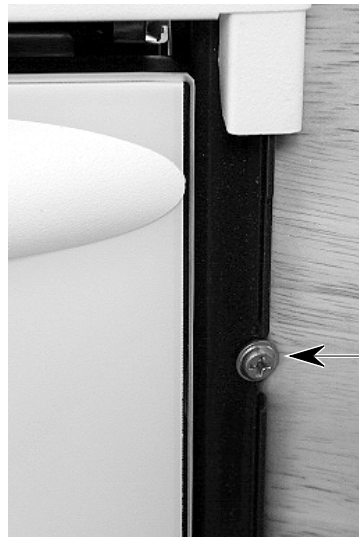

Cabinet Mounting
 Screw (1 On Each
 Side)

! WARNING

Excessive Weight Hazard

Use two or more people to remove and reinstall the microwave oven.

Failure to follow this instruction can result in back, or other injury.

7. Slide the microwave oven out of its mounting location.

REMOVING THE OVEN CONTROL & DISPLAY BOARDS AND THE TOUCH PANEL ASSEMBLY

! WARNING

Electrical Shock Hazard

Disconnect power before servicing.
Replace all panels before operating.
Failure to do so could result in death or electrical shock.

CAUTION: When you work on the microwave oven, be careful when handling the sheet metal parts. Sharp edges may be present, and you can cut yourself if you are not careful.

1. Disconnect the electrical power to the microwave oven.
2. Pull the microwave oven assembly forward several inches so that you can access the sides of the front panel (see page 2-2 for the side trim and mounting screw removal procedure).
3. Remove the screws from the oven control panel.



Oven Control Panel Screw
(1 On Each Side)

4. To remove the oven control panel, pull it out at the bottom, and lift and unhook it from the oven cabinet support at the top.

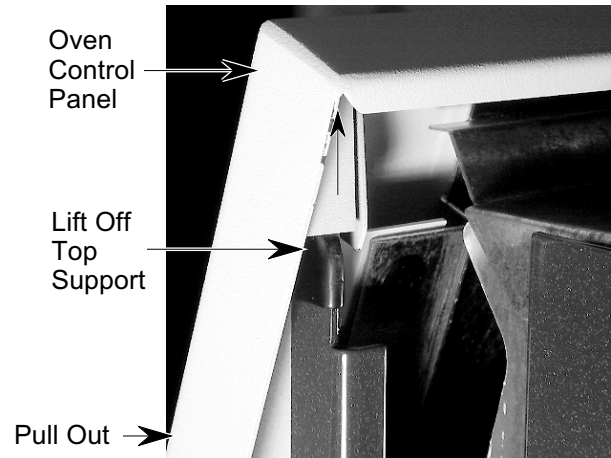

5. Pull the ground clip on the end of the green wire from the edge of the metal panel, and disconnect the wire connectors from the board. Set the panel face down on a padded surface to protect the finish.

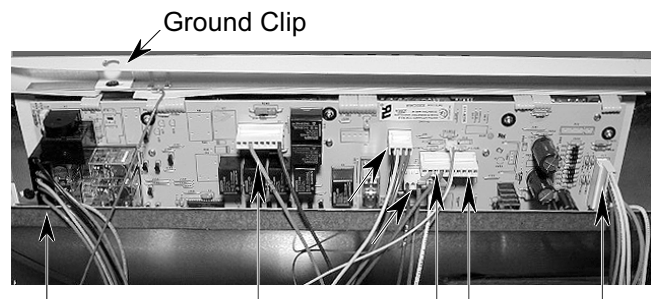

Wire Connectors

Continued on the next page.

6. **To remove the oven control & display boards:**

- a) Remove the seven mounting screws.
- b) Lift the ends of the locking arm and disconnect the ribbon cable from its connector.

NOTE: The control and display boards are designed to be replaced as an assembly.

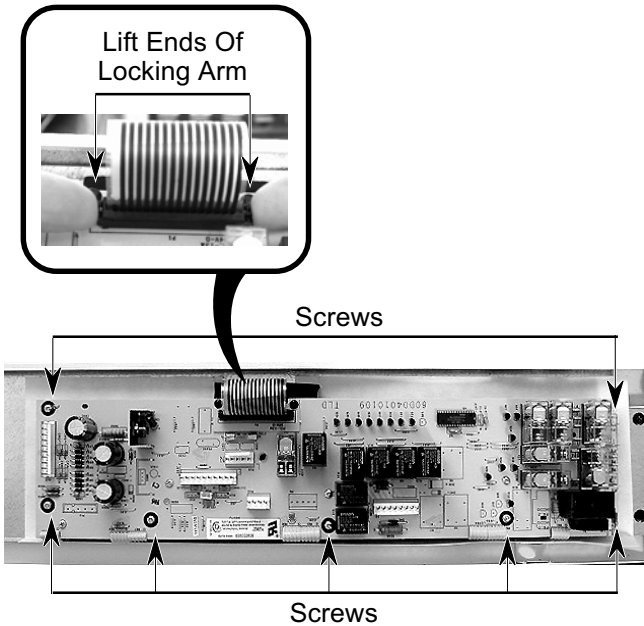

7. **To remove the touch panel assembly:**

- a) Remove the standoffs and spacers from over the mounting studs.

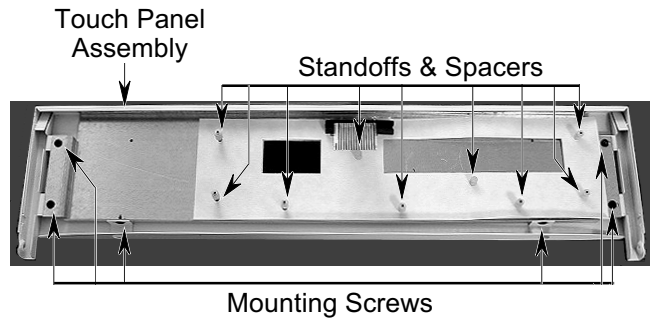

- b) Remove the six mounting screws.
- c) Lift the touch panel assembly off the front of the oven cabinet.

REASSEMBLY NOTE: When you reinstall the oven control panel, use the following procedure (refer to the photos on the previous page, as necessary):

- 1. Reconnect the wiring to the control board terminals.
- 2. Clip the ground wire to the metal edge of the control panel.
- 3. Hook the ends of the control panel over the rubber tips of the brackets.
- 4. Push the bottom of the control panel in and position the plastic air duct under the lip of the panel.



- 5. Align the mounting holes and install the two side screws in the control panel.

REMOVING THE LOW VOLTAGE TRANSFORMER, THE LIGHT POWER SUPPLY, & SUPPRESSOR BOARD

! WARNING

Electrical Shock Hazard

Disconnect power before servicing.
Replace all panels before operating.
Failure to do so could result in death or electrical shock.

CAUTION: When you work on the microwave oven, be careful when handling the sheet metal parts. Sharp edges may be present, and you can cut yourself if you are not careful.

1. Disconnect the electrical power to the microwave oven.
2. Remove the microwave oven assembly from its mounting location (see page 2-2 for the procedure).
3. Remove the screw from the power conduit clamp and remove the clamp.
4. Remove the 10 screws from the top front and top rear oven cabinet covers.

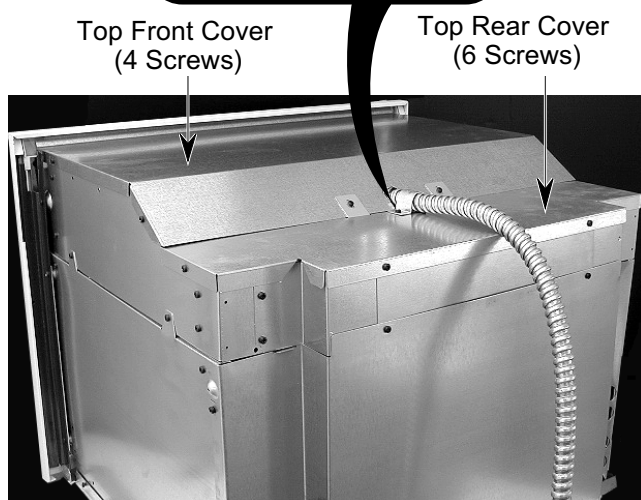
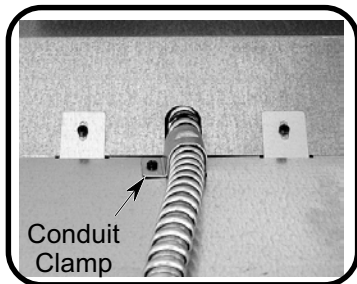

5. To remove the low voltage transformer:
 - a) Disconnect the 10-hole connector from the control board at P17.
 - b) Remove the mounting screw at the top and unhook the bottom transformer tab from the oven cabinet slot.

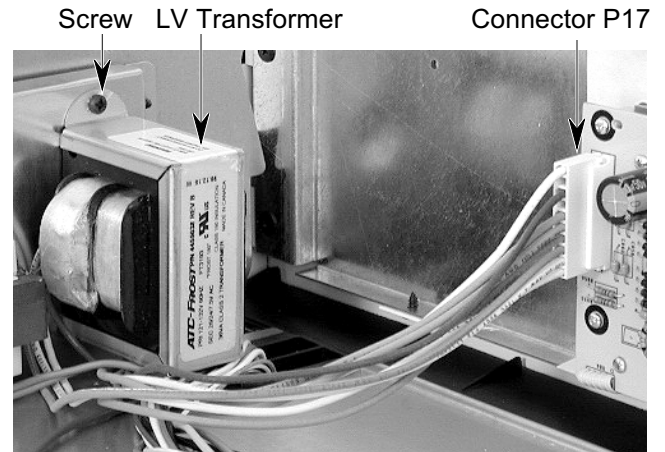

6. To remove the light power supply:
 - a) Disconnect the four wires from the LINE and LOAD terminals. Note that the LINE terminals are smaller than the LOAD terminals to prevent miswiring.
 - b) Remove the mounting screw and unhook the tab from the oven cabinet slot.

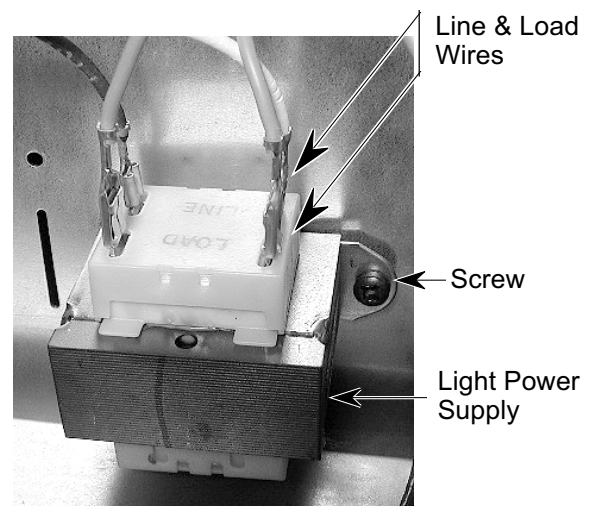

Continued on the next page.

7. **To remove the suppressor board:**

- a) Remove the hex nuts from the black and white wires and remove the wires from the screw terminals.
- b) Remove the mounting screw holding the suppressor board to the terminal strip.

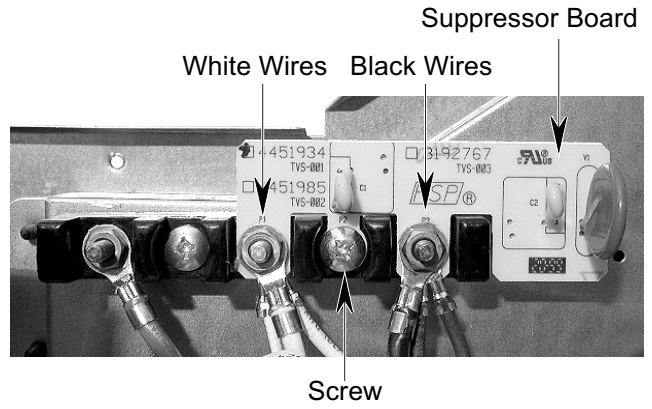

REMOVING THE BLOWER MOTOR ASSEMBLY

! WARNING

Electrical Shock Hazard

Disconnect power before servicing.
Replace all panels before operating.
Failure to do so could result in death or electrical shock.

CAUTION: When you work on the microwave oven, be careful when handling the sheet metal parts. Sharp edges may be present, and you can cut yourself if you are not careful.

1. Disconnect the electrical power to the microwave oven.
2. Remove the microwave oven assembly from its mounting location (see page 2-2 for the procedure).
3. Remove the top rear cover (see page 2-5).
4. Position the microwave oven assembly with the back facing you.
5. Remove the two top screws from the rear cover and remove the air vent cover.

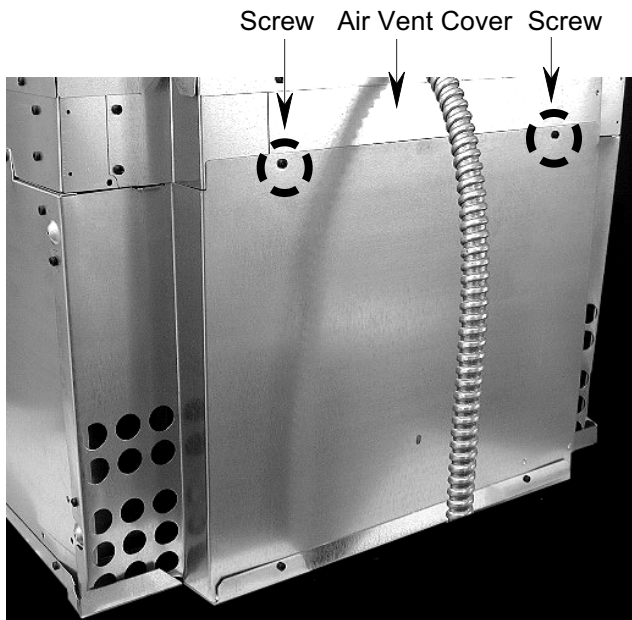

6. Remove the four screws from the blower cover and remove the cover.

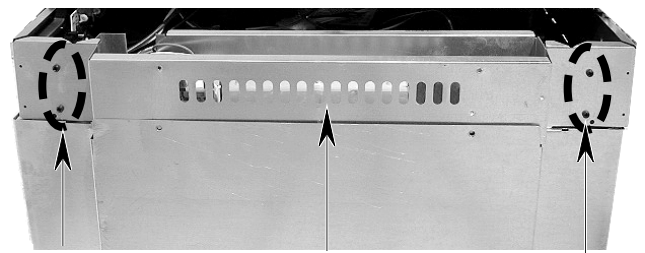

7. Disconnect the two wires from the blower motor terminals.

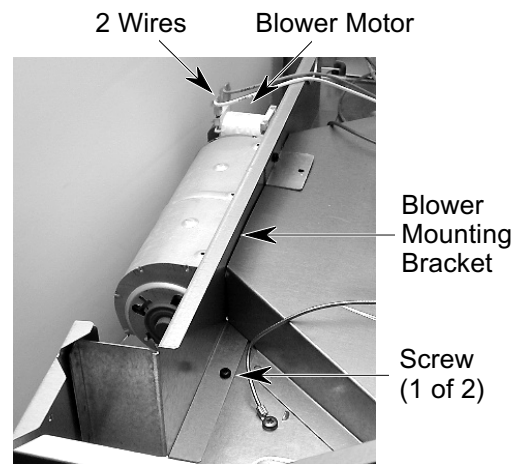

8. Remove the two screws from the blower mounting bracket and remove the bracket and blower.
9. Remove the four mounting screws from the blower motor assembly and remove it from the bracket.

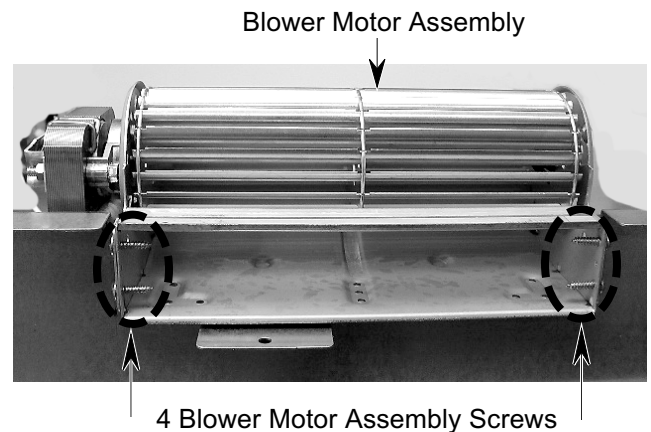

REMOVING THE MICROWAVE OVEN FROM THE OVEN CABINET

! WARNING

Electrical Shock Hazard

Disconnect power before servicing.
Replace all panels before operating.
Failure to do so could result in death or electrical shock.

CAUTION: When you work on the microwave oven, be careful when handling the sheet metal parts. Sharp edges may be present, and you can cut yourself if you are not careful.

1. Disconnect the electrical power to the microwave oven.
2. Remove the oven control assembly (see page 2-3 for the procedure).
3. Remove the three air vent screws and remove the air vent.

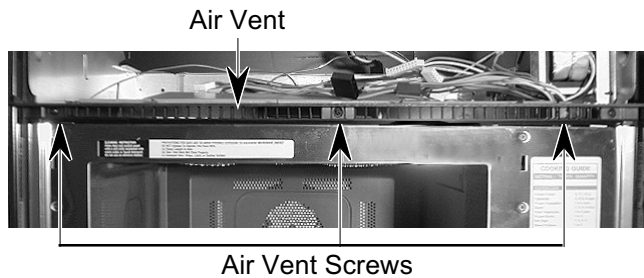

4. Remove the two screws from the bottom air vent and remove the vent.

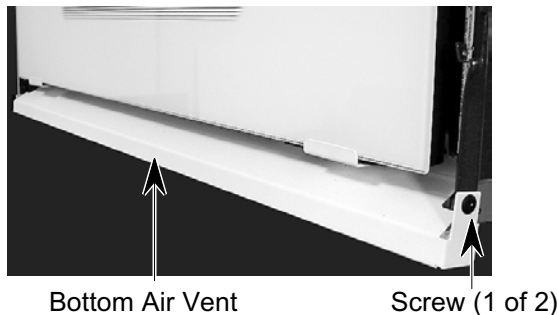

5. Remove the two screws from the lower microwave mounting brackets.

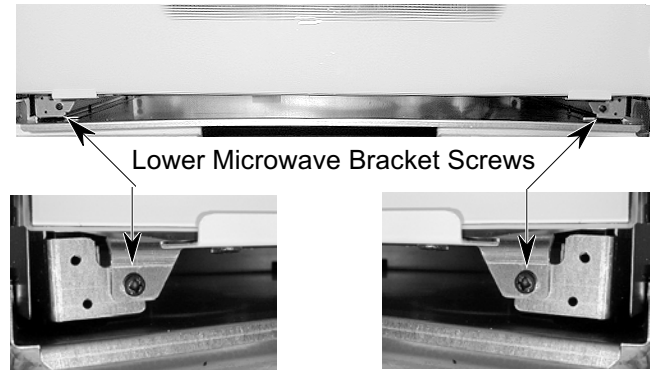

6. Pull the microwave oven out of the oven cabinet approximately four inches.
7. Disconnect the two red LOAD wires from the light power supply, the 6-pin connector, and the green ground wire in the top of the oven cabinet.

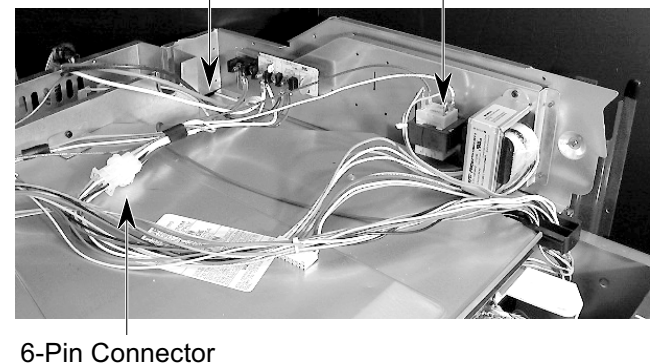
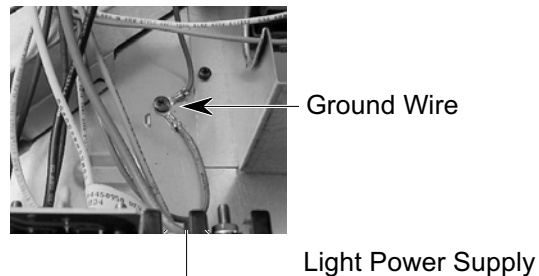

8. Slide the plastic grommet and the microwave oven out of the oven cabinet and set the oven on your work surface.

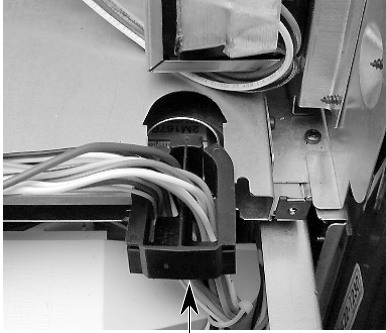

Plastic Grommet

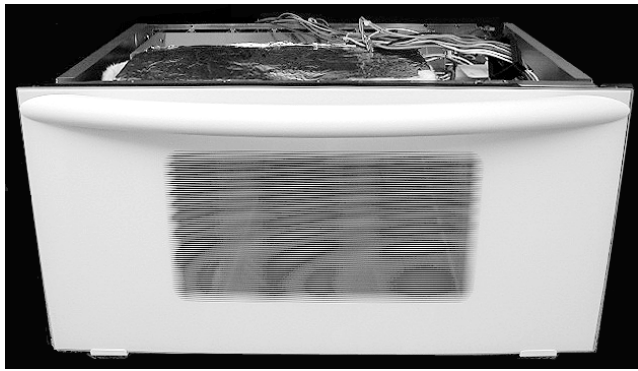

REASSEMBLY NOTE: When you reinstall the microwave oven in the oven cabinet, push it straight in so that the two rear alignment screws fit into the holes in the rear of the microwave oven.

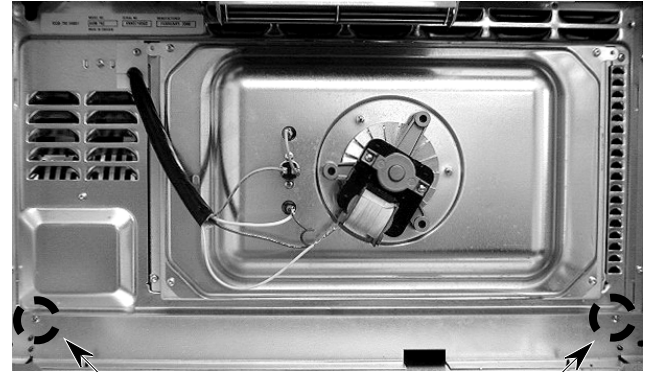

Microwave Oven Alignment Screws

REMOVING THE PRIMARY, SECONDARY, & MONITOR INTERLOCK SWITCHES AND THE AIR PRESSURE RELIEF VALVE

! WARNING

Electrical Shock Hazard

Disconnect power before servicing.
Replace all panels before operating.
Failure to do so could result in death or electrical shock.

CAUTION: When you work on the microwave oven, be careful when handling the sheet metal parts. Sharp edges may be present, and you can cut yourself if you are not careful.

1. Disconnect the electrical power to the microwave oven.
2. **To remove the secondary interlock switch:**
 - a) Remove the microwave oven from the oven cabinet (see pages 2-8 & 2-9 for the procedure).
 - b) Remove the six screws from the left side panel and remove the panel.

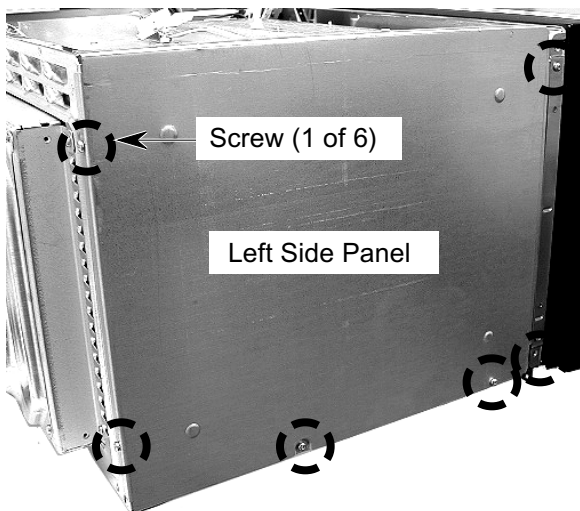

- c) Remove the wires from the switch terminals.

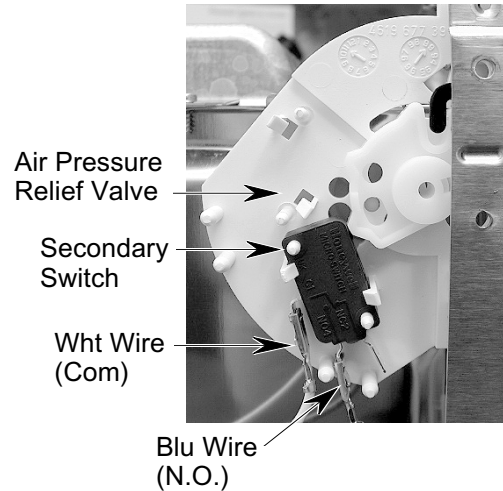

- d) Unclip the switch from the air pressure relief valve. **NOTE:** Be careful when removing the switch. The clips are very fragile and break easily.
3. **To remove the air pressure relief valve:**
 - a) Remove the secondary interlock switch (see step 2 for the procedure).
 - b) Remove the two T-10 torx flat-head screws and remove the relief valve.

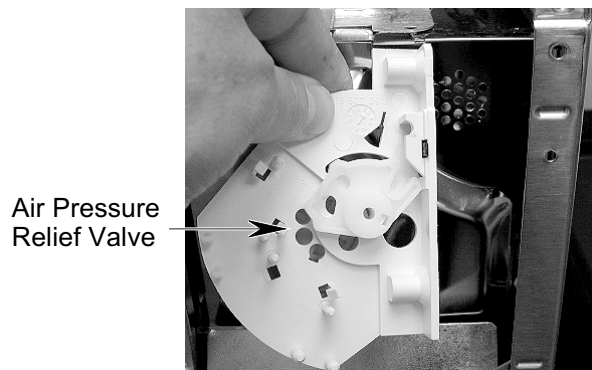

4. **To remove the primary and monitor interlock switches:**

- a) Pull the microwave oven out of the oven cabinet approximately 6" so you can access the interlock switches (see pages 2-8 & 2-9 for the procedure).
- b) Open the microwave oven door.
- c) Remove the two T-10 torx flat-head screws from the primary and monitor switch bracket.

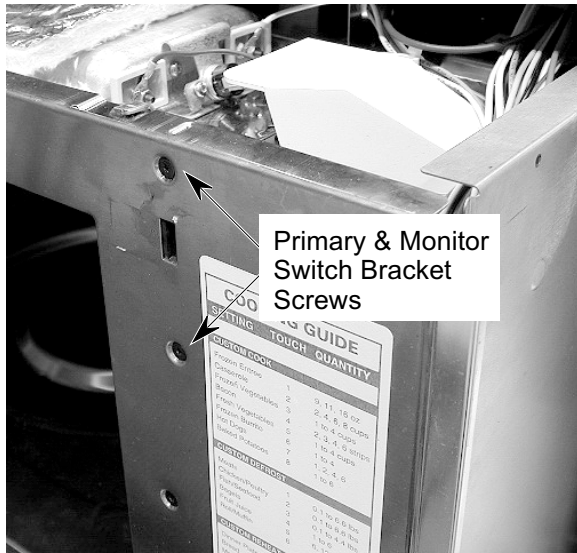

- d) Disconnect the wires from the primary and monitor switch terminals. A switch is mounted on both sides of the bracket.

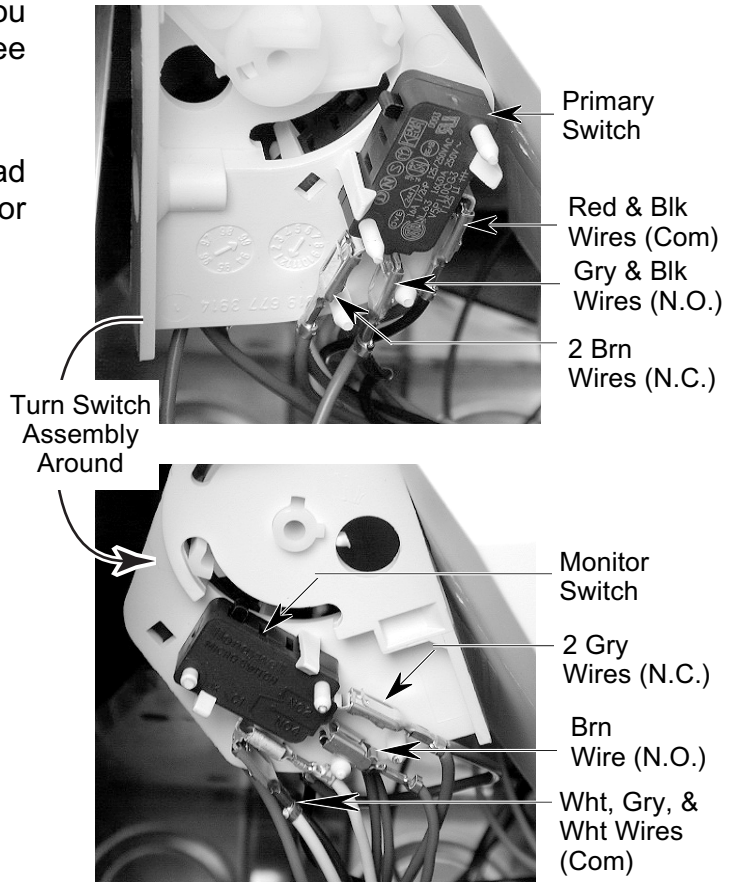

- e) Unclip and remove the primary and monitor switches from the bracket. **NOTE:** Be careful when removing the switches. The clips are very fragile and break easily.

REMOVING THE GRILL THERMAL FUSE AND THE GRILL ELEMENT ASSEMBLY

! WARNING

Electrical Shock Hazard

Disconnect power before servicing.
Replace all panels before operating.
Failure to do so could result in death or electrical shock.

CAUTION: When you work on the microwave oven, be careful when handling the sheet metal parts. Sharp edges may be present, and you can cut yourself if you are not careful.

1. Disconnect the electrical power to the microwave oven.
2. Remove the microwave oven from the oven cabinet (see pages 2-8 & 2-9 for the procedure).

The microwave oven components described on these pages are shown below.

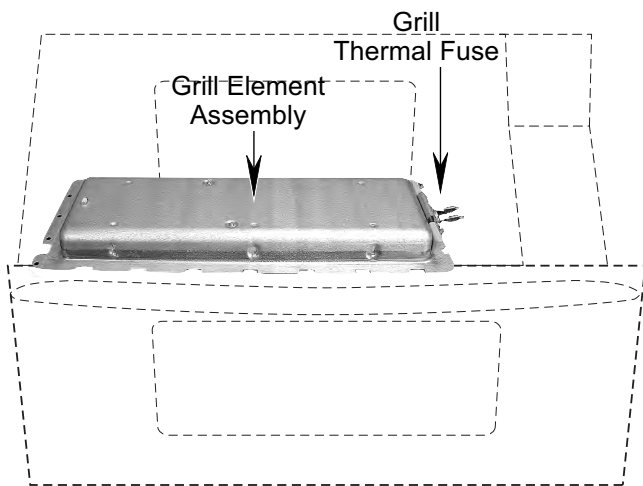

3. To remove the grill thermal fuse:

- a) Disconnect the two wires from the terminals.

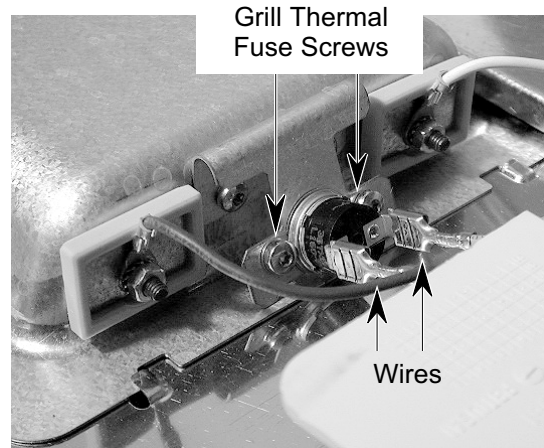

- b) Remove the two thermal fuse mounting screws.

4. To remove the grill element assembly:

- a) Remove the two T-10 torx screws from the plate over the left end of the grill element bracket and remove the plate.

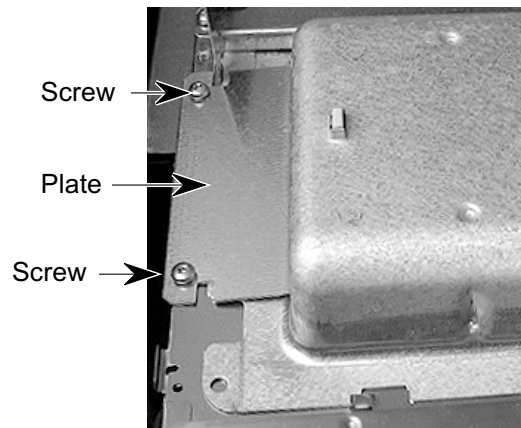

- b) Remove the two T-10 torx screws from the bracket over the left end of the grill element assembly and raise the bracket slightly.

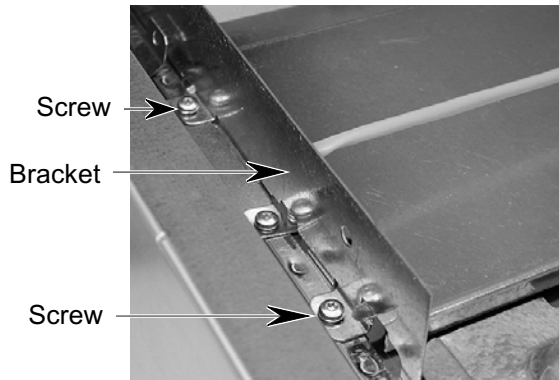

- c) Slide the grill element assembly to the left and release the slots from the locking tabs. NOTE: It may take a moderate amount of force to do this.

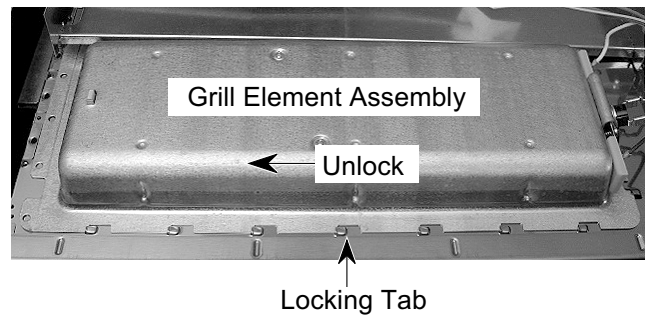

- d) Remove the two T-10 torx screws from the grill thermal fuse bracket and remove the fuse and bracket.

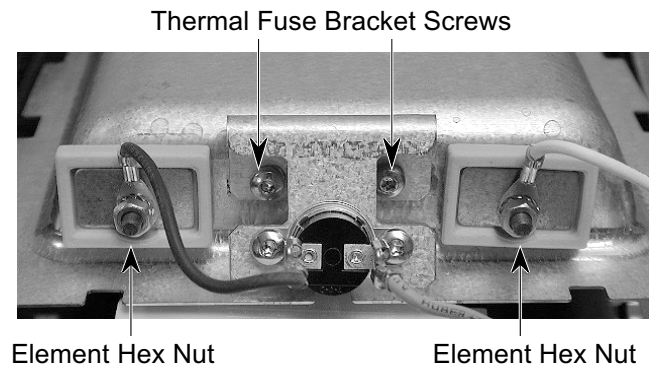

- e) Remove the two hex nuts from the grill element studs and remove the wires.

REMOVING THE CONVECTION TEMPERATURE SENSOR, THE HALOGEN LAMP, AND THE CAVITY THERMAL FUSE

! WARNING

Electrical Shock Hazard

Disconnect power before servicing.
Replace all panels before operating.
Failure to do so could result in death or electrical shock.

CAUTION: When you work on the microwave oven, be careful when handling the sheet metal parts. Sharp edges may be present, and you can cut yourself if you are not careful.

1. Disconnect the electrical power to the microwave oven.
2. Remove the microwave oven from the oven cabinet (see pages 2-8 & 2-9 for the procedure).

The microwave oven components described on these pages are shown below.

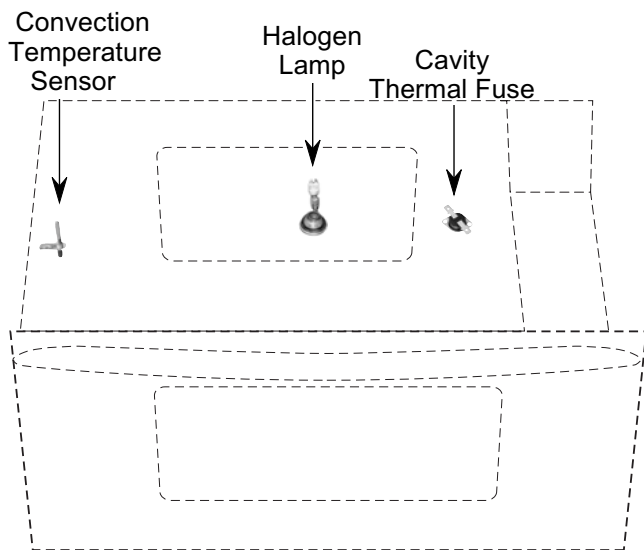

3. To remove the convection temperature sensor:

- a) Remove the two T-10 torx screws from the plate over the left end of the grill element bracket and remove the plate.

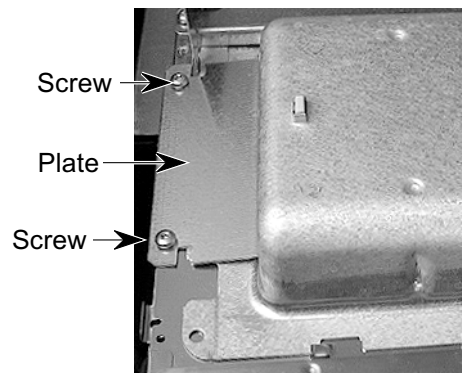

- b) Remove the two T-10 torx screws from the bracket over the left end of the grill element assembly and raise the bracket.

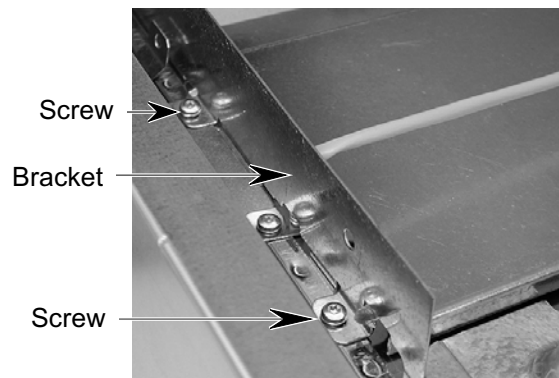

- c) Remove the T-10 torx screw from the sensor.

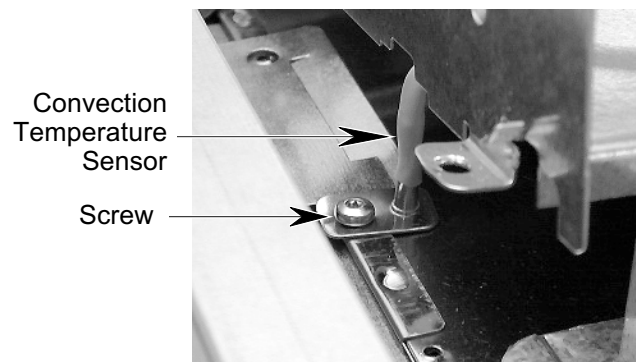

- d) Remove the two sensor wires from the harness.

4. **To remove the halogen lamp:**

- a) Unclip the wire retainer and remove it.

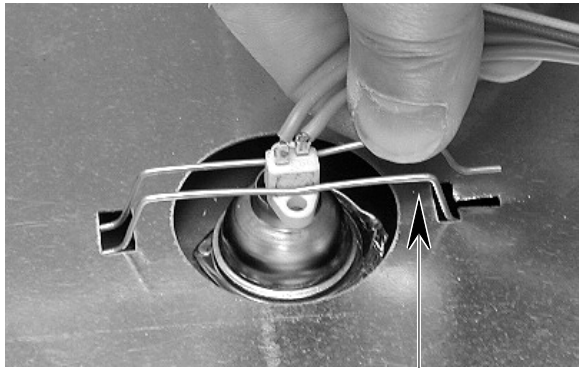

Wire Retainer

- b) Remove the lamp from the holder and remove the wires from the harness.

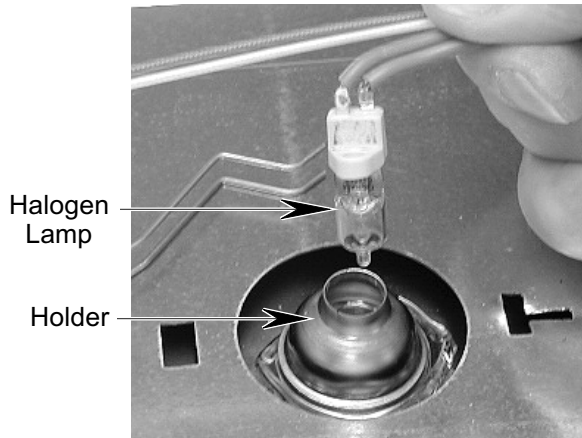

5. **To remove the cavity thermal fuse:**

- a) Disconnect the wires from the terminals.
b) Remove the T-10 torx screw from the cavity thermal fuse.

Cavity Thermal Fuse Screw

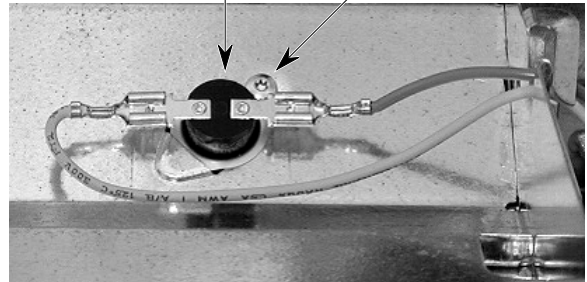

REMOVING THE CONVECTION THERMAL FUSE, CONVECTION ELEMENT, AND CONVECTION FAN MOTOR

⚠️ WARNING

Electrical Shock Hazard

Disconnect power before servicing.
Replace all panels before operating.
Failure to do so could result in death or electrical shock.

CAUTION: When you work on the microwave oven, be careful when handling the sheet metal parts. Sharp edges may be present, and you can cut yourself if you are not careful.

1. Disconnect the electrical power to the microwave oven.
2. Remove the microwave oven from the oven cabinet (see pages 2-8 & 2-9 for the procedure).
3. Position the microwave oven with the back facing you.
4. **To remove the convection thermal fuse:**
 - a) Disconnect the wires from the terminals.
 - b) Remove the two T-10 torx screws.

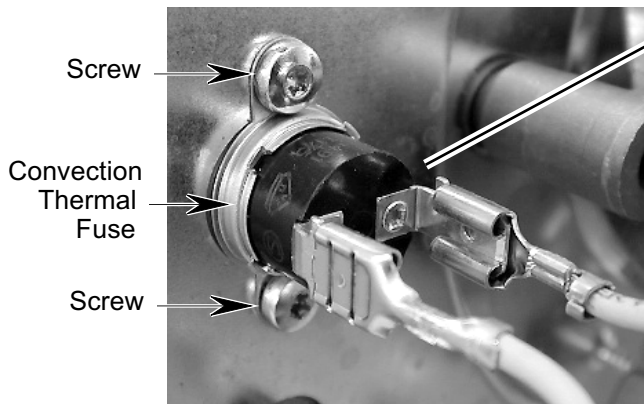

5. **To remove the convection element:**
 - a) Disconnect the wires from the terminals.
 - b) Remove the four T-10 torx screws from the mounting cover.

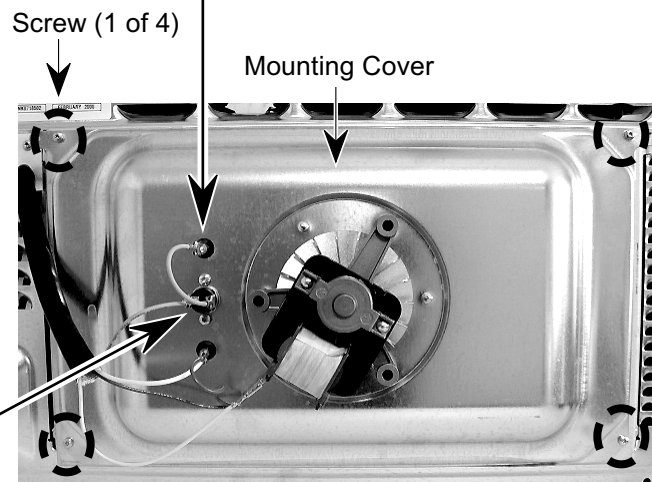
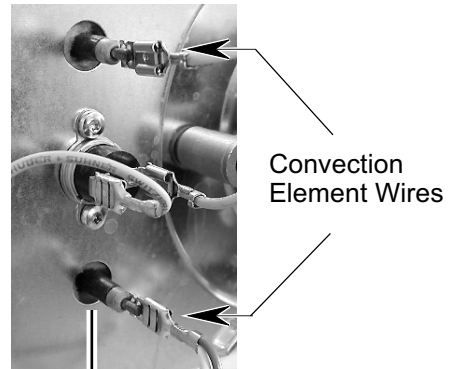

Back Of Oven

- c) Turn the cover around so that the convection element faces you and remove the three T-10 torx screws from the element.

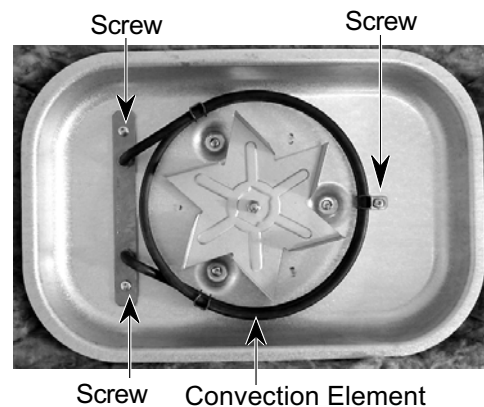

6. **To remove the convection fan motor:**

- a) Remove the convection element (see step 5). NOTE: It is not necessary to remove the convection element to remove the fan motor. However, there is a possibility of damaging the element while removing the motor, so it is advisable to remove it.
- b) Disconnect the wires from the convection fan motor terminals.

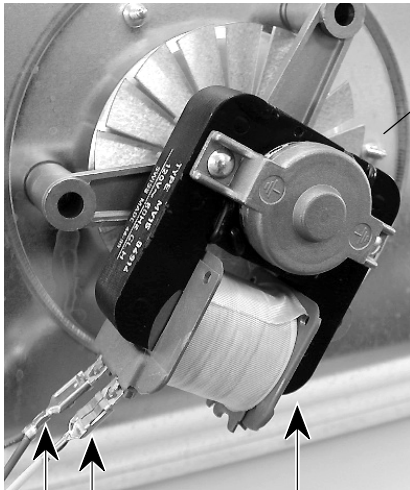

Wires Convection Fan Motor

CAUTION: Be very careful when handling the fan in the next step. The edges are very sharp.

- c) Remove the acorn nut from the fan motor shaft and remove the fan and flat washer beneath it.

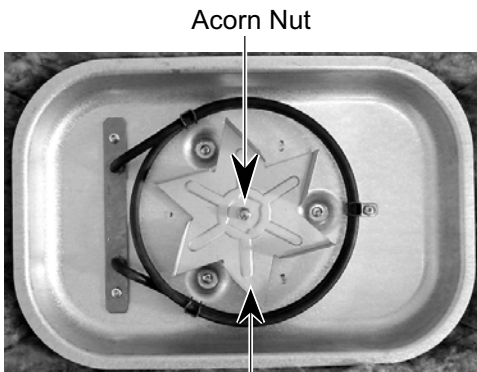

Acorn Nut
Convection Motor Fan

- d) Remove the three T-10 torx screws from the insulation cover and remove the cover and insulation.

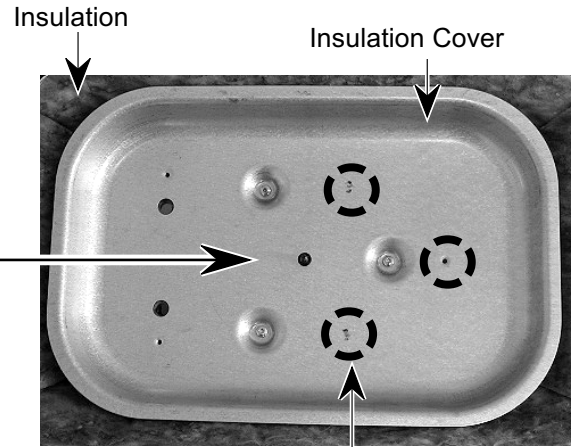

Cover Screws (1 of 3)

- e) Unsnap the e-ring from the motor shaft and remove the ring and flat washer.

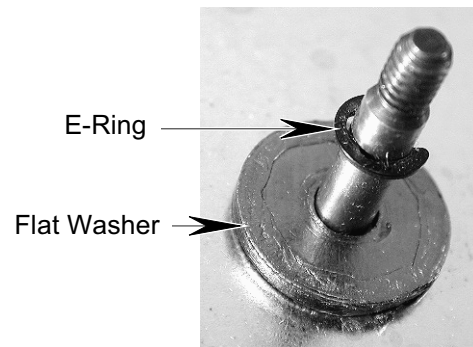

- f) Remove the three 5/32" allen screws from the motor and remove the motor from the cover.

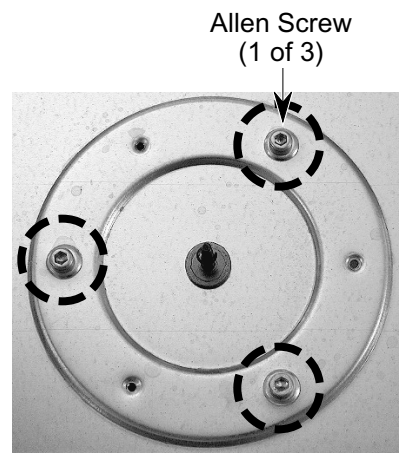

REMOVING THE COOLING FAN MOTOR & AIR VENT SOLENOID

! WARNING

Electrical Shock Hazard

Disconnect power before servicing.
Replace all panels before operating.
Failure to do so could result in death or electrical shock.

CAUTION: When you work on the microwave oven, be careful when handling the sheet metal parts. Sharp edges may be present, and you can cut yourself if you are not careful.

1. Disconnect the electrical power to the microwave oven.
2. Remove the microwave oven from the oven cabinet (see pages 2-8 & 2-9 for the procedure).
3. Open the microwave oven door and remove the turntable and the spindle from the turntable motor shaft.
4. Remove the right side panel (see step 2b on page 2-10 for the procedure).
5. Position the microwave oven on its left side.
6. Remove the four T-10 torx screws from the cooling fan housing.

Torx Screws (1 of 4) Cooling Fan Housing

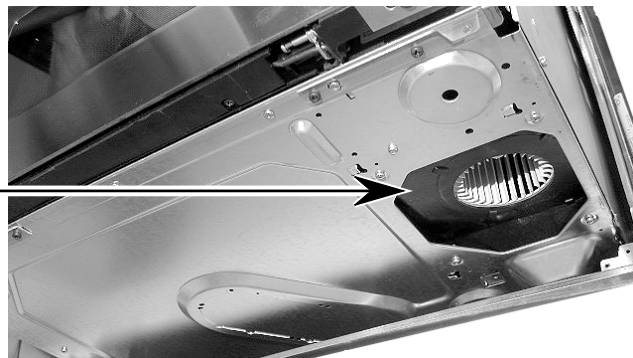
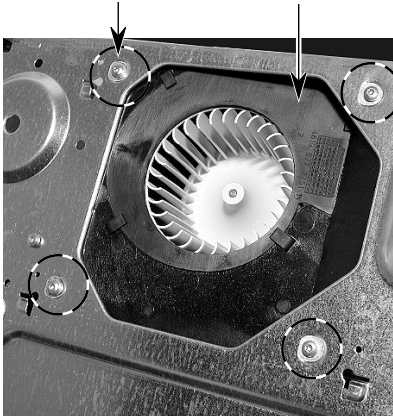

7. Position the unit with the high voltage component side facing you.
8. Pull the cooling fan assembly out of the unit.
9. **To remove the cooling fan motor:**
 - a) Disconnect the wires from the terminals.

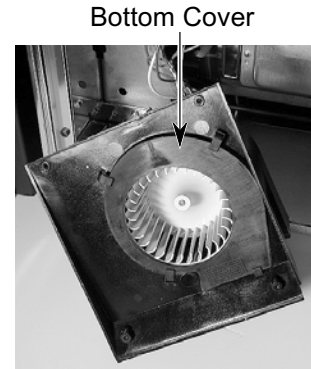
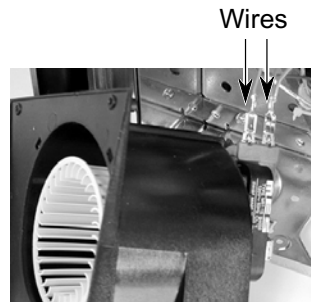

- b) Unclip the bottom cover from the cooling fan housing and remove the cover.
- c) Pull the fan off the motor shaft.

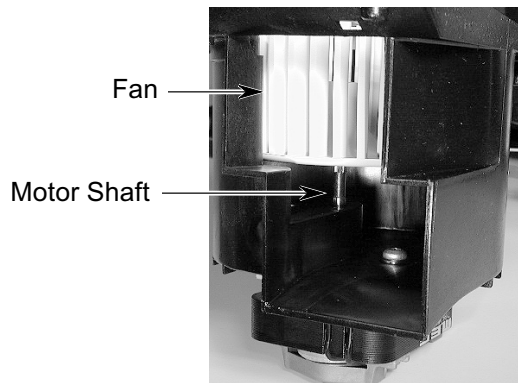

- d) Remove the T-10 torx screws from the fan motor and remove the motor from the housing.



The microwave oven component described on this page is shown below.

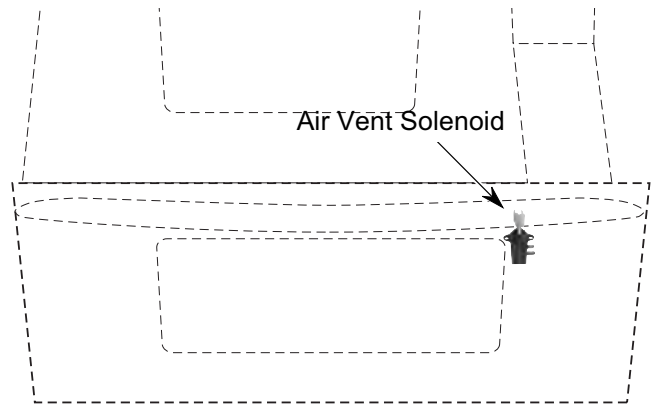

10. To remove the air vent solenoid:

- a) Disconnect the wires from the terminals.
- b) Remove the T-10 torx screw.
- c) Unclip the actuator from the solenoid shaft.

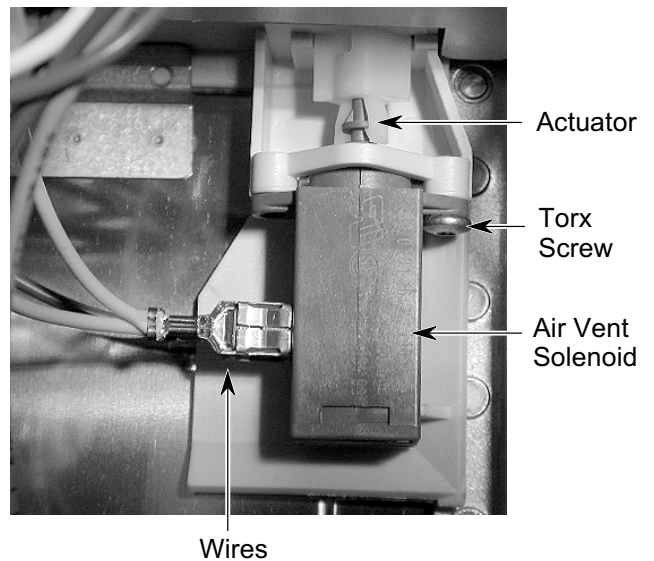

REMOVING THE MAGNETRON THERMAL FUSE AND THE MAGNETRON

! WARNING

Electrical Shock Hazard

Disconnect power before servicing.
Replace all panels before operating.
Failure to do so could result in death or electrical shock.

CAUTION: When you work on the microwave oven, be careful when handling the sheet metal parts. Sharp edges may be present, and you can cut yourself if you are not careful.

1. Disconnect the electrical power to the microwave oven.
2. Remove the microwave oven from the oven cabinet (see pages 2-8 & 2-9 for the procedure).
3. Open the microwave oven door and remove the turntable and rollers.
4. Remove the right side panel (see step 2b on page 2-10 for the procedure).

CAUTION: Discharge the high voltage capacitor terminals with a 20,000 Ω resistor to chassis ground.

The microwave oven components described on these pages are shown below.

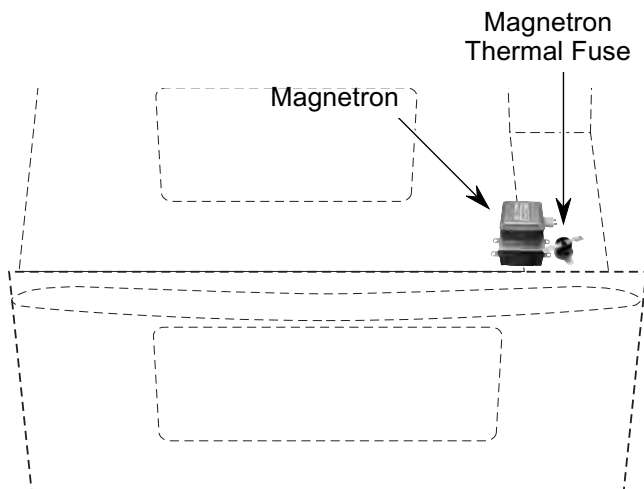

5. To remove the magnetron thermal fuse:

- a) Remove the wires from the thermal fuse cover clips.
- b) Remove the T-10 torx screw from the thermal fuse cover and remove the cover.

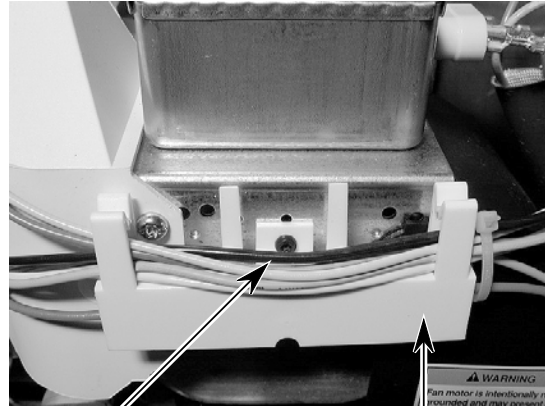

Screw Thermal Fuse Cover

- c) Remove the remaining T-10 torx screw from the thermal fuse.

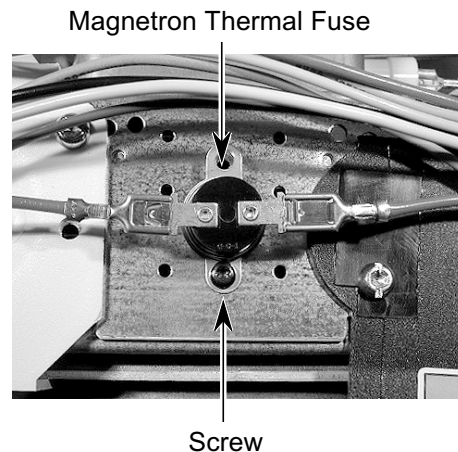

6. **To remove the magnetron:**
 - a) Remove the magnetron thermal fuse (see step 5).
 - b) Remove the T-16 torx screws (1 each) from the left and right air ducts.

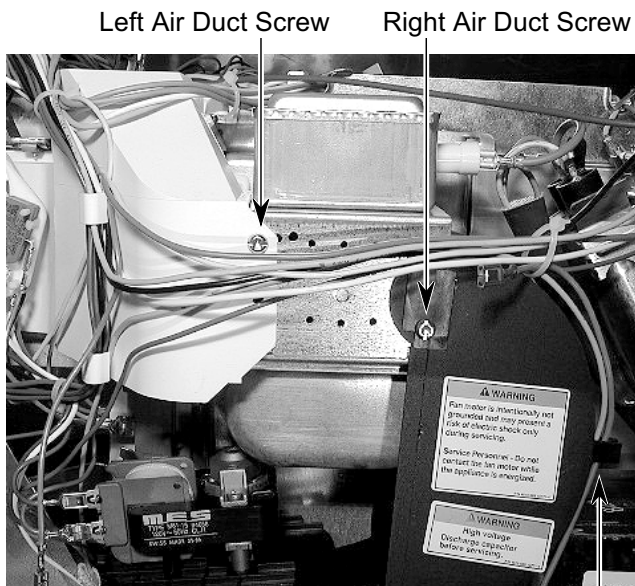

- c) Unclip the two wires from the right air duct and remove the duct.

- d) Disconnect the two filament wires from the magnetron terminals.

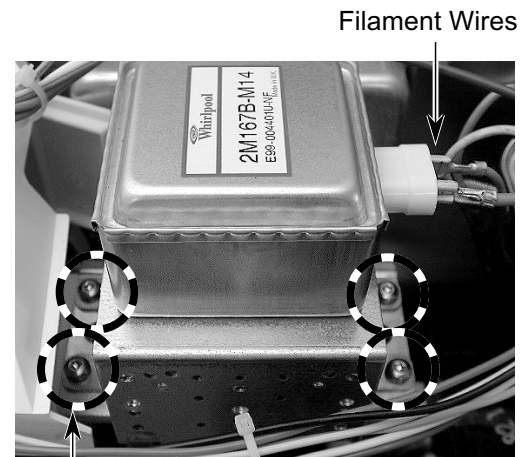

Screw (1 of 4)

- e) Remove the four T-16 magnetron torx screws and remove the magnetron. **NOTE:** Move the left air duct back far enough to access the magnetron screws.

IMPORTANT REASSEMBLY NOTE: When you mount the magnetron, loosely install the four screws, and then tighten them in a cross-tightening (opposite corner) sequence. Make sure that the base of the magnetron stays parallel with the mounting surface so that it is not tilted; otherwise, it may not work properly.

REMOVING THE HIGH VOLTAGE TRANSFORMER

! WARNING

Electrical Shock Hazard

Disconnect power before servicing.
Replace all panels before operating.
Failure to do so could result in death or electrical shock.

CAUTION: When you work on the microwave oven, be careful when handling the sheet metal parts. Sharp edges may be present, and you can cut yourself if you are not careful.

1. Disconnect the electrical power to the microwave oven.
2. Remove the microwave oven from the oven cabinet (see pages 2-8 & 2-9 for the procedure).
3. Remove the right side panel (see step 2b on page 2-10 for the procedure).

CAUTION: Discharge the high voltage capacitor terminals with a 20,000 Ω resistor to chassis ground.

The microwave oven component described on these pages is shown below.

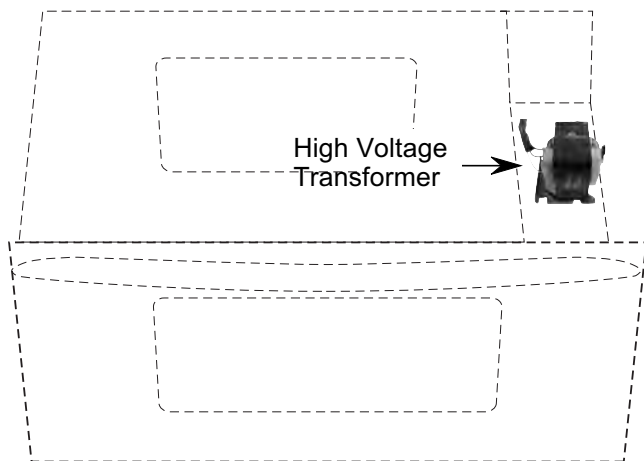

4. Remove the T-16 torx screw from the air duct, unclip the two wires, and remove the duct.

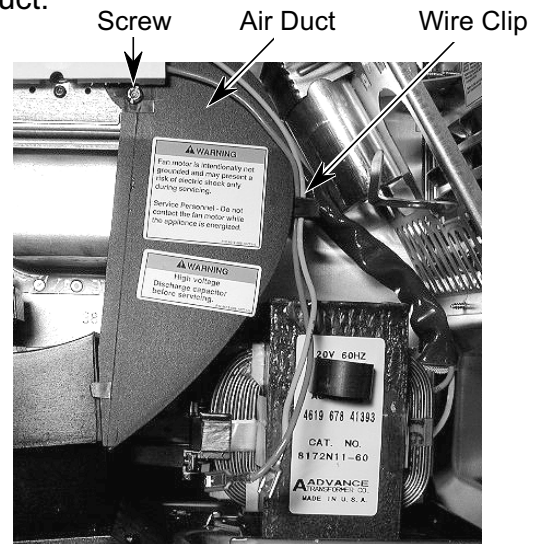

5. Disconnect the two wires from the primary terminals of the high voltage transformer, and the three secondary wires from the magnetron, and high voltage capacitor terminals.

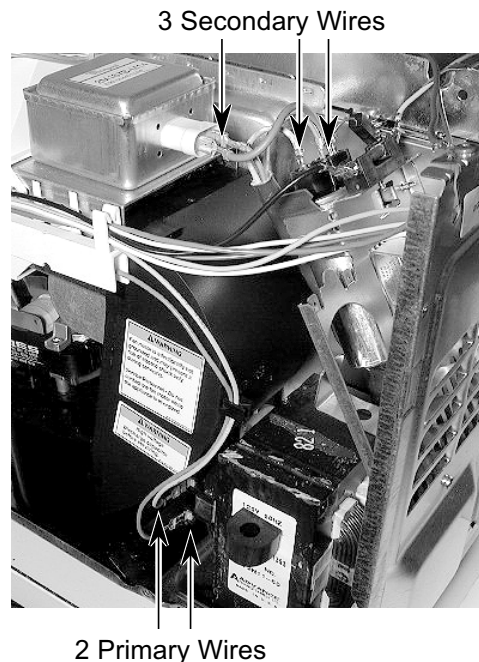

6. Remove the two T-10 torx screws from the high voltage transformer, then pull the two base tabs out of the chassis, and remove the high voltage transformer.

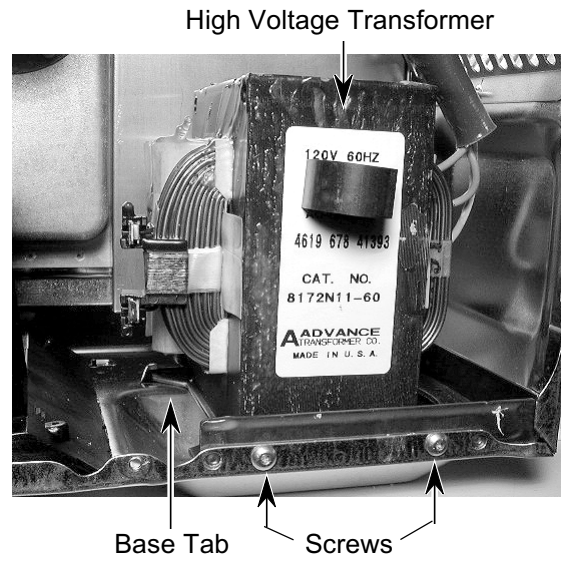

REMOVING THE LINE FUSE & FUSEHOLDER, THE HIGH VOLTAGE RECTIFIER, & HIGH VOLTAGE CAPACITOR

! WARNING

Electrical Shock Hazard

Disconnect power before servicing.
 Replace all panels before operating.
 Failure to do so could result in death or electrical shock.

CAUTION: When you work on the microwave oven, be careful when handling the sheet metal parts. Sharp edges may be present, and you can cut yourself if you are not careful.

1. Disconnect the electrical power to the microwave oven.
2. Remove the microwave oven from the oven cabinet (see pages 2-8 & 2-9 for the procedure).
3. Remove the right side panel (see step 2b on page 2-10 for the procedure).

CAUTION: Discharge the high voltage capacitor terminals with a 20,000 Ω resistor to chassis ground.

The microwave oven components described on these pages are shown below.

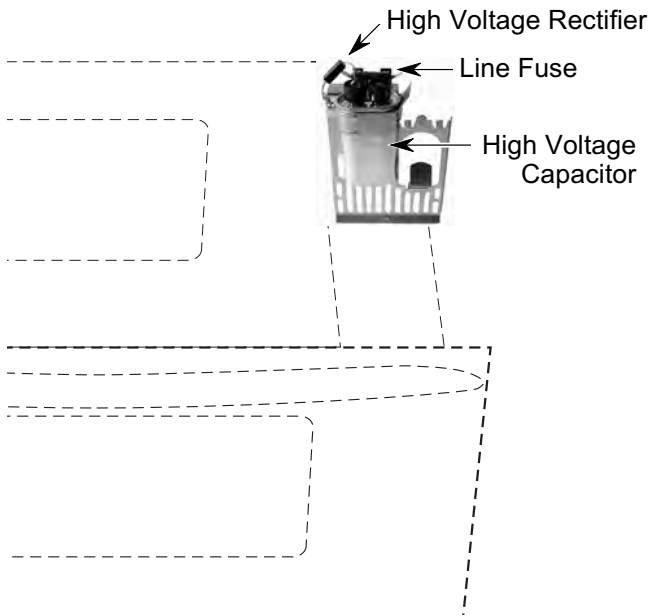

4. To remove the line fuse and fuseholder:
 - a) Remove the line fuse from the fuseholder.
 - b) Remove the wires from the fuseholder terminals.
 - c) Remove the T-10 torx screw from the fuseholder.

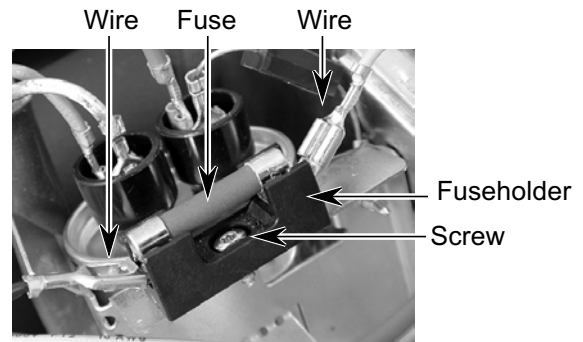

5. To remove the high voltage rectifier and high voltage capacitor:
 - a) Remove the wires from the fuseholder and high voltage capacitor terminals.

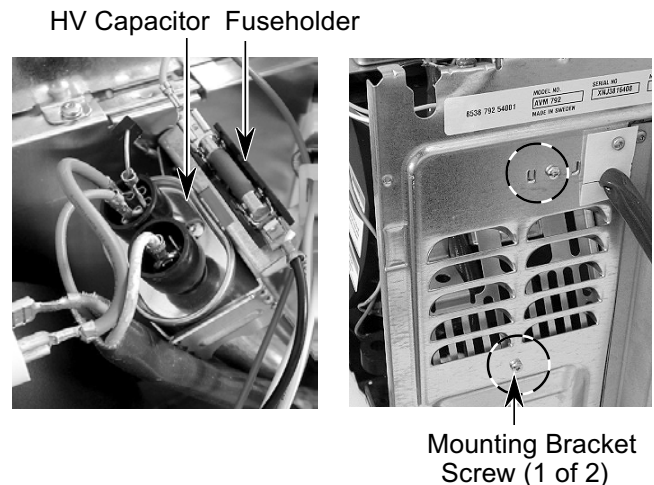

- b) Remove the mounting bracket screws from the rear panel.

- c) Unclip the wires from the mounting bracket clip.

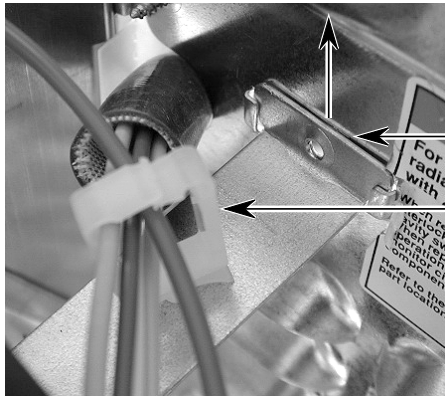

Bracket Arm

Wire Clip

- d) Lift the arm out of the rear panel track, and remove the mounting bracket assembly.

- e) Remove the high voltage rectifier lead from the high voltage capacitor terminal.
- f) Remove the mounting screw from the capacitor clamp and remove the high voltage rectifier and capacitor from the mounting bracket.

High Voltage Capacitor

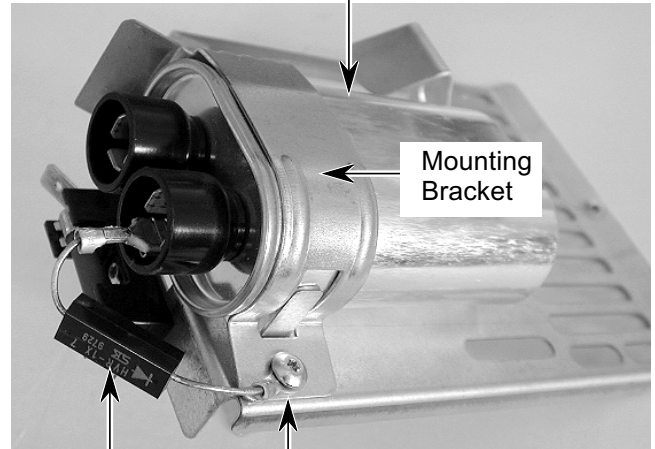

Mounting Bracket

High Voltage Rectifier

Clamp Screw

REMOVING THE TURNTABLE MOTOR

! WARNING

Electrical Shock Hazard

Disconnect power before servicing.
Replace all panels before operating.
Failure to do so could result in death or electrical shock.

CAUTION: When you work on the microwave oven, be careful when handling the sheet metal parts. Sharp edges may be present, and you can cut yourself if you are not careful.

1. Disconnect the electrical power to the microwave oven.
2. Remove the microwave oven from the oven cabinet (see pages 2-8 & 2-9 for the procedure).
3. Open the microwave oven door and remove the turntable and rollers.
4. Pull the spindle off the turntable motor shaft.
5. Position the microwave oven on its left side.
6. Use a pair of wire cutters and cut the metal between the two holes at the four indicated locations on the turntable motor knockout, and remove it.

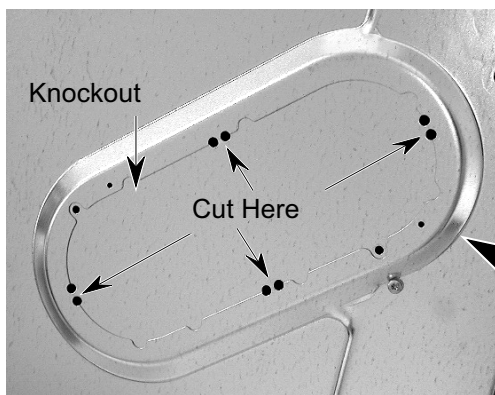

7. Remove the T-10 torx screws from the turntable motor and remove the motor.

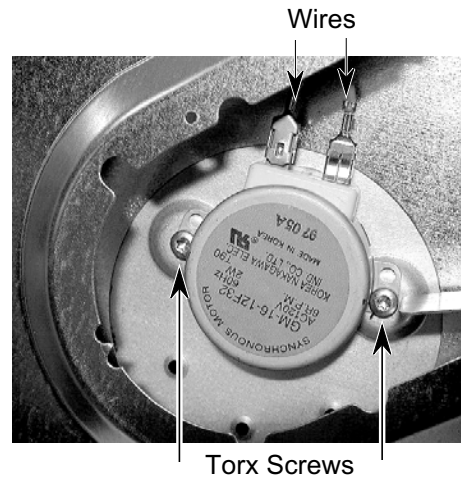

8. Disconnect the wires from the turntable motor terminals.

REASSEMBLY NOTE: Use two #6 x 1/4" screws to mount the knockout over the turntable motor cutout.

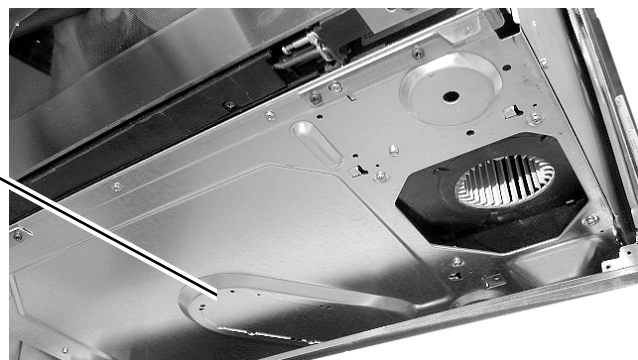
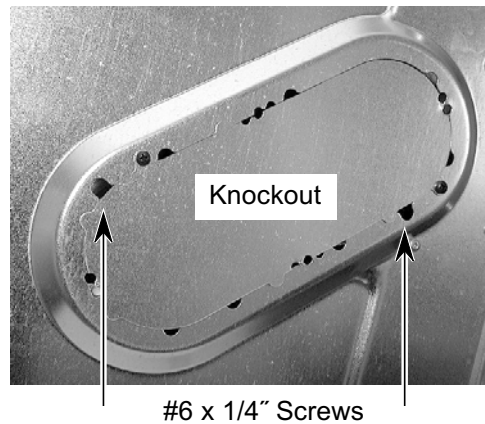

REMOVING THE OVEN DOOR HANDLE & FRONT DOOR GLASS

⚠️ WARNING

Electrical Shock Hazard

Disconnect power before servicing.
Replace all panels before operating.
Failure to do so could result in death or electrical shock.

CAUTION: When you work on the microwave oven, be careful when handling the sheet metal parts. Sharp edges may be present, and you can cut yourself if you are not careful.

1. Disconnect the electrical power to the microwave oven.
2. Remove the microwave oven from the oven cabinet (see pages 2-8 & 2-9 for the procedure).
3. Remove the left and right side panels from the microwave (see step 2b on page 2-10 for the procedure).
4. Remove the screws (1 each) from the two clips at the bottom of the door and remove the clips.

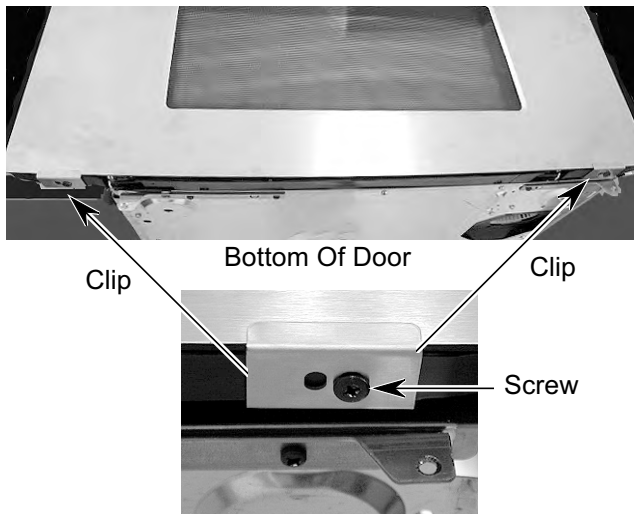

CAUTION: When you remove the front door glass and handle in the next step, be careful when you remove the two screws that hold the assembly together. Hold the door open while you remove the screws; otherwise the door will spring closed. Also, be careful not to drop the glass and handle assembly when you remove the screws.

5. Open the oven door and remove the two screws from the inside of the door panel, then remove the front door glass and handle from the door, and carefully close the oven door.

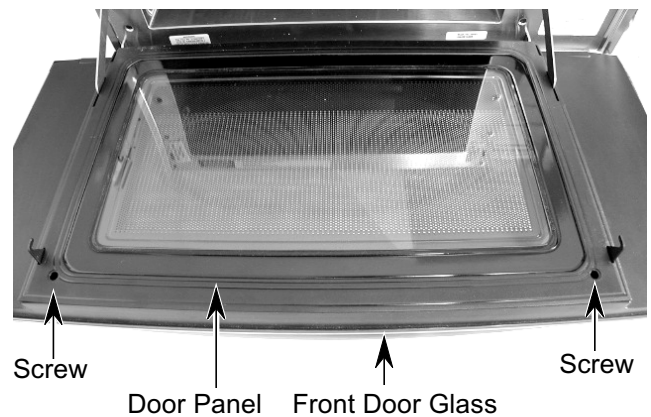

6. Remove the four screws from the handle support bracket, and remove the handle and bracket from the front door glass.

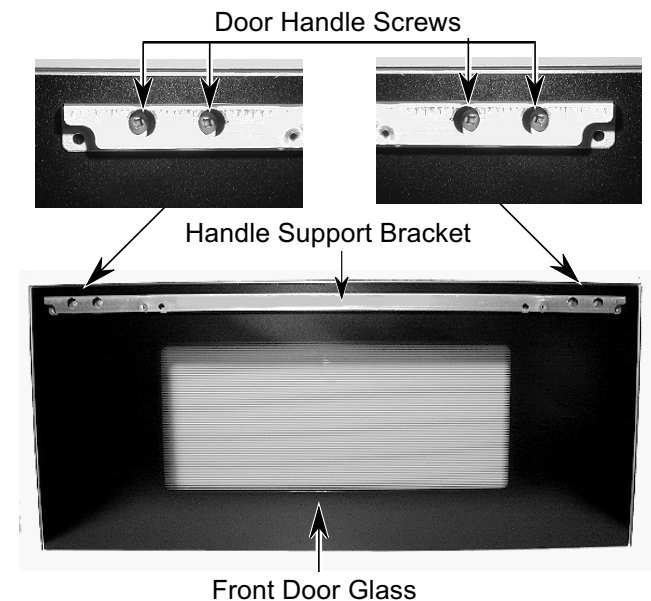

REMOVING THE OVEN DOOR & THE INNER GLASS

! WARNING

Electrical Shock Hazard

Disconnect power before servicing.
Replace all panels before operating.
Failure to do so could result in death or electrical shock.

CAUTION: When you work on the microwave oven, be careful when handling the sheet metal parts. Sharp edges may be present, and you can cut yourself if you are not careful.

1. Disconnect the electrical power to the microwave oven.
2. Remove the microwave oven from the oven cabinet (see pages 2-8 & 2-9 for the procedure).
3. Remove the left and right side panels from the microwave (see step 2b on page 2-10 for the procedure).

NOTE: The inner door glass cannot be replaced separately. The oven door and inner glass must be replaced as an assembly.

4. Remove the T-10 torx shoulder screws from the door stops (1 on each side).

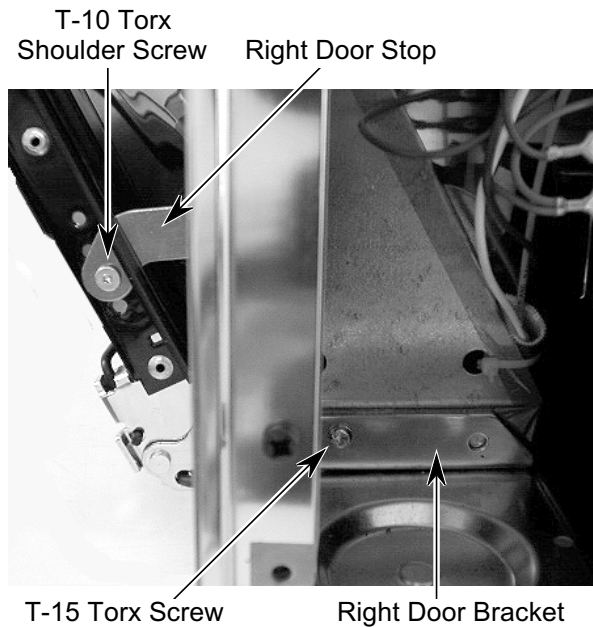

5. Remove the T-15 torx screws from the sides of the door brackets (1 on each side).
6. Remove the two bottom screws from the door panel and remove the panel.

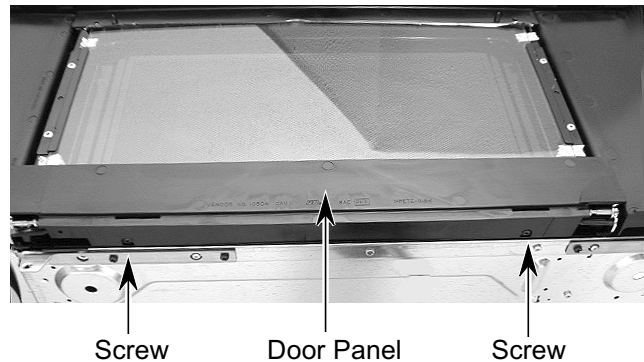

Bottom Of Unit

7. Remove the four indicated T-10 torx screws from the bottom of the door brackets.

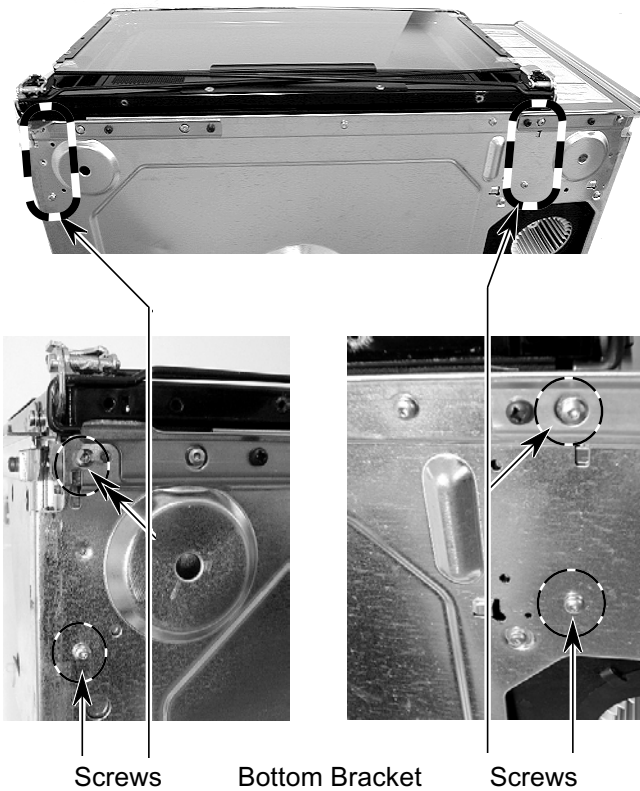

8. Pull the brackets out of the oven slots and remove the door assembly from the microwave.



9. If you are replacing the oven door and inner glass assembly, remove the front door glass and the handle (see page 2-27 for the procedure).

— NOTES —

COMPONENT TESTING

Before testing any of the components, perform the following checks:

- The most common cause for control failure is corrosion on connectors. Therefore, disconnecting and reconnecting wires will be necessary throughout test procedures.
- All tests/checks should be made with a VOM or DVM having a sensitivity of 20,000 ohms-per-volt DC, or greater.
- Check all connections before replacing components, looking for broken or loose wires, failed terminals, or wires not pressed into connectors far enough.
- Voltage checks must be made with all connectors attached to the boards.
- Resistance checks must be made with power cord unplugged from outlet, and with wiring harness or connectors disconnected.

THE TURNTABLE & COOLING FAN MOTORS

! WARNING

Electrical Shock Hazard

Disconnect power before servicing.
Replace all panels before operating.
Failure to do so could result in death or electrical shock.

! WARNING

Electrical Shock Hazard

Disconnect power before servicing.
Replace all panels before operating.
Failure to do so could result in death or electrical shock.

TURNTABLE MOTOR

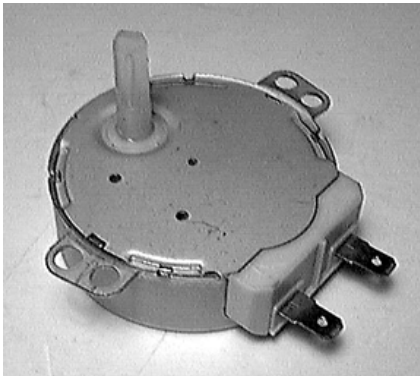

Refer to page 2-26 for the procedure for servicing the turntable motor.

1. Disconnect the electrical power to the microwave oven.
2. Disconnect the wires from the turntable motor terminals.
3. Set the ohmmeter to the R x 1 scale.
4. Touch the ohmmeter leads to the motor terminals. The meter should indicate approximately 25 Ω .

COOLING FAN MOTOR

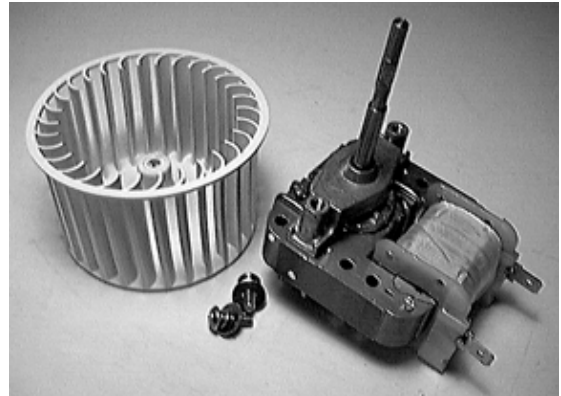

Refer to page 2-18 for the procedure for servicing the cooling fan motor.

1. Disconnect the electrical power to the microwave oven.
2. Disconnect the wires from the cooling fan motor terminals.
3. Set the ohmmeter to the R x 1 scale.
4. Touch the ohmmeter leads to the motor terminals. The meter should indicate approximately 25 Ω .

THE LOW VOLTAGE TRANSFORMER & LIGHT POWER SUPPLY

! WARNING

Electrical Shock Hazard

Disconnect power before servicing.
Replace all panels before operating.
Failure to do so could result in death or electrical shock.

! WARNING

Electrical Shock Hazard

Disconnect power before servicing.
Replace all panels before operating.
Failure to do so could result in death or electrical shock.

LOW VOLTAGE TRANSFORMER

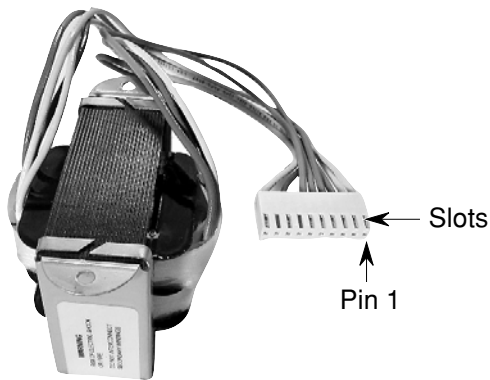

Refer to page 2-5 for the procedure for servicing the low voltage transformer.

1. Disconnect the electrical power to the microwave oven.
2. Disconnect the low voltage transformer connector from the oven control board.
3. Set the ohmmeter to the R x 1 scale.
4. Touch the ohmmeter leads to the indicated slots of the low voltage transformer connector. The meter should indicate as follows:
 - 1st Secondary—Pins 1 & 2 = Less than 1 Ω .
 - 2nd Secondary—Pins 3 & 4 = Less than 1 Ω .
 - 3rd Secondary—Pins 5 & 6 = Less than 1 Ω .
 - Primary—Pins 8 & 10 = Approximately 5 Ω .

LIGHT POWER SUPPLY

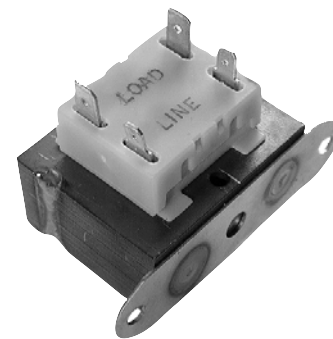

Refer to page 2-5 for the procedure for servicing the light power supply.

1. Disconnect the electrical power to the microwave oven.
2. Disconnect one of the wires from each of the light power supply LOAD and LINE terminals.
3. Set the ohmmeter to the R x 1 scale.
4. Touch the ohmmeter leads to the LOAD terminals. The meter should indicate less than 1 Ω .
5. Touch the ohmmeter leads to the LINE terminals. The meter should indicate approximately 46 Ω .

THE BLOWER & CONVECTION FAN MOTORS

! WARNING

Electrical Shock Hazard

Disconnect power before servicing.
Replace all panels before operating.
Failure to do so could result in death or electrical shock.

BLOWER MOTOR

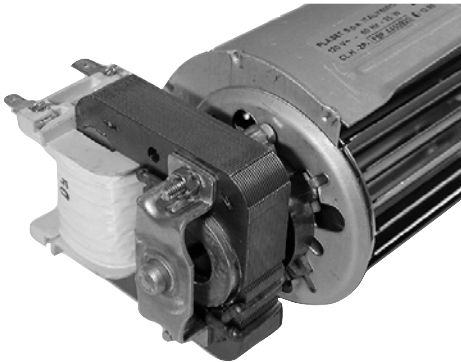

Refer to page 2-7 for the procedure for servicing the blower motor.

1. Disconnect the electrical power to the microwave oven.
2. Disconnect the wires from the blower motor terminals.
3. Set the ohmmeter to the R x 1 scale.
4. Touch the ohmmeter leads to the motor terminals. The meter should indicate approximately 25 Ω .

! WARNING

Electrical Shock Hazard

Disconnect power before servicing.
Replace all panels before operating.
Failure to do so could result in death or electrical shock.

CONVECTION FAN MOTOR



Refer to page 2-16 for the procedure for servicing the convection fan motor.

1. Disconnect the electrical power to the microwave oven.
2. Disconnect the wires from the convection fan motor terminals.
3. Set the ohmmeter to the R x 1 scale.
4. Touch the ohmmeter leads to the motor terminals. The meter should indicate approximately 40 Ω .

THE CONVECTION TEMPERATURE SENSOR

! WARNING

Electrical Shock Hazard

Disconnect power before servicing.
Replace all panels before operating.
Failure to do so could result in death or electrical shock.



Refer to page 2-14 for the procedure for servicing the convection temperature sensor.

1. Disconnect the electrical power to the microwave oven.
2. Disconnect the convection temperature sensor connector from the oven control board.
3. Set the ohmmeter to the R x 1K scale.
4. Touch the ohmmeter leads to the sensor connector pins. The meter should indicate as shown in the chart below:

Convection Temperature Sensor Chart

Room Ambient:	15°C (59°F)	20°C (68°F)	25°C (77°F)	30°C (86°F)
Resistance (KΩ):	294.7-471.2	233.2-366.9	185.7-287.7	148.8-227.2

THE CAVITY, GRILL, CONVECTION, & MAGNETRON THERMAL FUSES

! WARNING

Electrical Shock Hazard

Disconnect power before servicing.
Replace all panels before operating.
Failure to do so could result in death or electrical shock.

Cavity



Grill & Convection



Magnetron



Refer to the cavity thermal fuse (page 2-14), the grill thermal fuse (page 2-12), the convection thermal fuse (page 2-16), and the magnetron thermal fuse (page 2-20) for the servicing procedures.

1. Disconnect the electrical power to the microwave oven.
2. Disconnect the wires from the terminals of the thermal fuse under test.
3. Set the ohmmeter to the R x 1 scale.
4. Touch the ohmmeter leads to the thermal fuse terminals. The meter should indicate as follows:

Cavity:	Opens @ 165°C (329°F) Non-Resettable
Grill:	Opens @ 160°C (320°F) Closes @ 140°C (284°F)
Convection:	Opens @ 145°C (293°F) Closes @ 105°C (221°F)
Magnetron:	Opens @ 145°C (293°F) Closes @ 125°C (257°F)

THE CONVECTION ELEMENT & GRILL ELEMENT ASSEMBLY

! WARNING

Electrical Shock Hazard

Disconnect power before servicing.
Replace all panels before operating.
Failure to do so could result in death or electrical shock.

CONVECTION ELEMENT

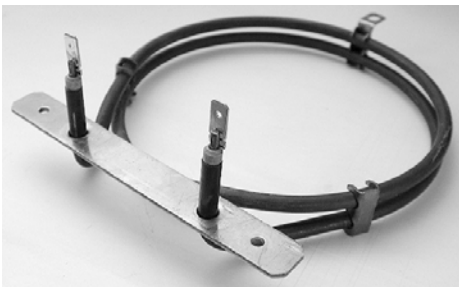

Refer to page 2-16 for the procedure for servicing the convection element.

1. Disconnect the electrical power to the microwave oven.
2. Disconnect the wires from the convection element terminals.
3. Set the ohmmeter to the R x 1 scale.
4. Touch the ohmmeter leads to the element terminals. The meter should indicate approximately 10 Ω .

! WARNING

Electrical Shock Hazard

Disconnect power before servicing.
Replace all panels before operating.
Failure to do so could result in death or electrical shock.

GRILL ELEMENT ASSEMBLY

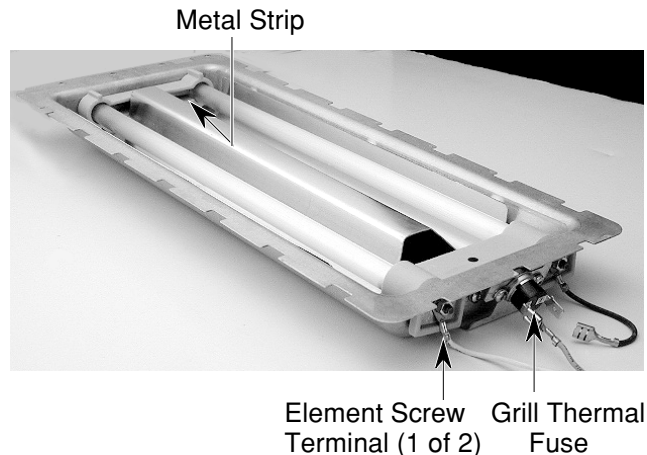

Refer to page 2-12 for the procedure for servicing the grill element assembly.

1. Disconnect the electrical power to the microwave oven.
2. Disconnect the black element wire from the grill thermal fuse terminal.
3. Set the ohmmeter to the R x 1 scale.
4. Touch one of the ohmmeter leads to the metal strip between the ends of the elements. Touch the other lead to one of the element screw terminals, and then the other element screw terminal. The meter should indicate approximately 7 Ω at each element screw terminal.
5. Touch the ohmmeter leads to each of the element screw terminals. The meter should indicate approximately 14 Ω .

THE LINE FUSE, HIGH VOLTAGE RECTIFIER, & HIGH VOLTAGE CAPACITOR

! WARNING

Electrical Shock Hazard

Disconnect power before servicing.
Replace all panels before operating.
Failure to do so could result in death or electrical shock.

Refer to page 2-24 for the procedure for servicing the line fuse, the high voltage rectifier (diode), and the high voltage capacitor.

1. Disconnect the electrical power to the microwave oven.

Line Fuse W/Fuseholder

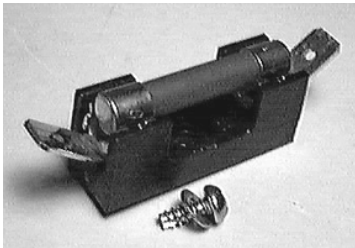

2. **To test the line fuse:**
 - a) Unclip the fuse from the fuseholder.
 - b) Set the ohmmeter to the R x 1 scale.
 - c) Touch the ohmmeter leads to the ends of the fuse. The meter should indicate continuity if the fuse is good. If the fuse is open, the meter will indicate infinity.

High Voltage Rectifier (Diode)

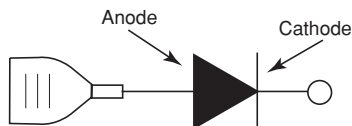
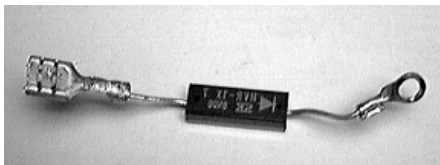

3. **To test the high voltage rectifier:**
 - a) Disconnect the diode lead from the high voltage capacitor.

- b) Set the ohmmeter to the R x 1K scale.
- c) Touch the positive ohmmeter lead to the anode lead of the diode and the negative lead to the cathode. The meter should indicate continuity.
- d) Reverse the ohmmeter leads on the diode and the meter should indicate infinity.

High Voltage Capacitor

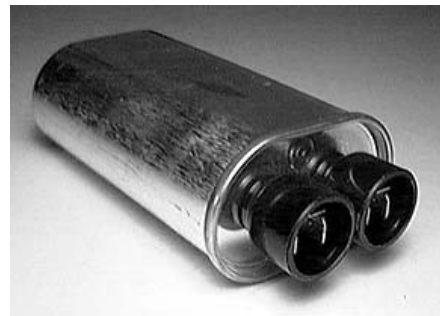

4. **To test the high voltage capacitor:**
 - a) Disconnect the diode and wires from the high voltage capacitor terminals.
 - b) Set the ohmmeter to the R x 1K scale.
 - c) Touch the ohmmeter leads to the capacitor terminals. The meter should indicate several ohms, and gradually return to infinity.
 - d) Touch one of the ohmmeter leads to the chassis and the other to the capacitor terminals. The meter should indicate infinity.

THE AIR VENT SOLENOID & INTERLOCK SWITCHES

! WARNING

Electrical Shock Hazard

Disconnect power before servicing.
Replace all panels before operating.
Failure to do so could result in death or electrical shock.

AIR VENT SOLENOID

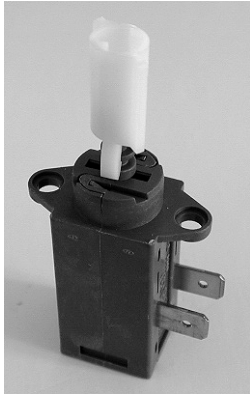

Refer to page 2-18 for the procedure for servicing the air vent solenoid.

1. Disconnect the electrical power to the microwave oven.
2. Disconnect the wire from one of the solenoid terminals.
3. Set the ohmmeter to the R x 1K scale.
4. Touch the ohmmeter leads to the terminals. The meter should indicate approximately 1650 Ω .

! WARNING

Electrical Shock Hazard

Disconnect power before servicing.
Replace all panels before operating.
Failure to do so could result in death or electrical shock.

INTERLOCK SWITCH (1 of 3)

Switch Actuator



Refer to page 2-10 for the procedure for servicing the interlock switches.

1. Disconnect the electrical power to the microwave oven.
2. Disconnect the wires from the interlock switch under test.
3. Set the ohmmeter to the R x 1 scale.
4. Touch the ohmmeter leads to the indicated terminals (shown embossed on the switch). The meter should indicate as follows:
COM to N.O. = infinity (no continuity)
COM to N.C. = 0 Ω (continuity)
5. Press the switch button, and touch the ohmmeter leads to the indicated terminals. The meter should indicate as follows:
COM to N.O. = 0 Ω (continuity)
COM to N.C. = infinity (no continuity)

THE HIGH VOLTAGE TRANSFORMER & MAGNETRON

! WARNING

Electrical Shock Hazard

Disconnect power before servicing.
Replace all panels before operating.
Failure to do so could result in death or electrical shock.

HIGH VOLTAGE TRANSFORMER

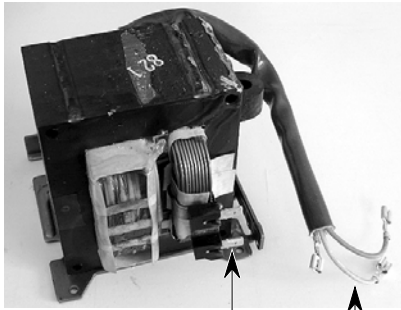

Primary Terminals 3 Secondary Wires

Refer to page 2-22 for the procedure for servicing the high voltage transformer.

1. Disconnect the electrical power to the microwave oven.
2. Disconnect the three high voltage transformer secondary wires from the high voltage capacitor and magnetron.
3. Disconnect the two wires from the primary terminals.
4. Set the ohmmeter to the R x 1 scale.
5. Touch the ohmmeter leads to the two primary terminals. The meter should indicate less than 1 Ω .
6. Touch the ohmmeter leads to the two orange/red (filament) wires. The meter should indicate less than 1 Ω .
7. Touch one ohmmeter lead to the light yellow secondary wire, and the other lead to the chassis. The meter should indicate 0 Ω .
8. Touch one ohmmeter lead to the primary and filament terminals, and the other lead to the chassis. The meter should indicate infinity.

! WARNING

Electrical Shock Hazard

Disconnect power before servicing.
Replace all panels before operating.
Failure to do so could result in death or electrical shock.

MAGNETRON

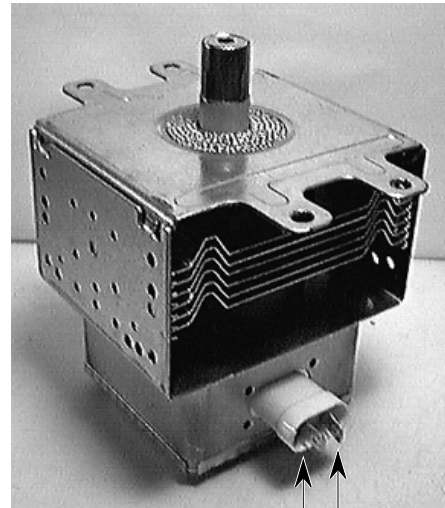

Filament Terminals

Refer to page 2-20 for the procedure for servicing the magnetron.

1. Disconnect the electrical power to the microwave oven.
2. Disconnect the wires from the filament terminals.
3. Set the ohmmeter to the R x 1 scale.
4. Touch the ohmmeter leads to the filament terminals. The meter should indicate approximately 0 Ω .
5. Set the ohmmeter to the R x 1K scale.
6. Touch one ohmmeter lead to the filament terminals, and the other lead to the chassis. The meter should indicate infinity.

CONTROL PANEL RESISTOR

! WARNING

Electrical Shock Hazard

Disconnect power before servicing.
Replace all panels before operating.
Failure to do so could result in death or electrical shock.

1. Disconnect the electrical power to the microwave oven.
2. Remove the control panel from the microwave oven (see page 2-3 for the procedure).
3. Set the ohmmeter to the R x 1K scale.
4. Touch the ohmmeter leads to the resistor leads. The meter should indicate approximately 1200 Ω .

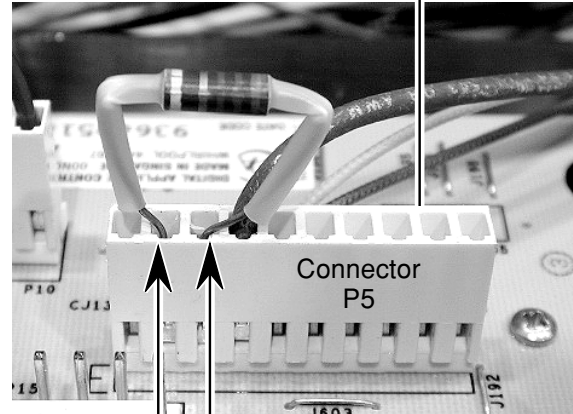
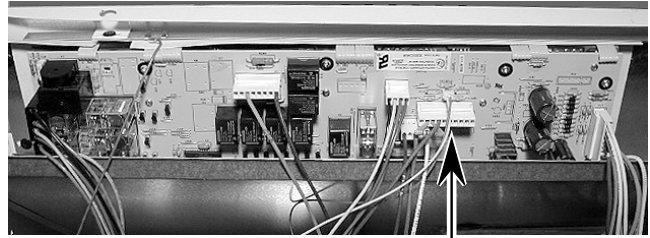

Measure 1200 Ω
Resistor Leads

DIAGNOSIS & TROUBLESHOOTING

FAILURE / ERROR DISPLAY CODES

- Always disconnect power before touching any internal parts in the oven.
- Upon replacement, immediately return the old electronic oven control using the mailing label that is supplied with each new control.

- The failure code is displayed on the side of the control that is hidden behind the membrane switch. The control will need to be unscrewed from the panel to see the hidden display.

FAULT CODE	ERROR CODE	MEANING OF FAILURE CODE	RECOMMENDED REPAIR PROCEDURE
F0	E0	Default F code - no failure	Will only be displayed if user presses and holds CANCEL key for 5 seconds and there is no pre-existing fault. Press CANCEL again to clear the display.
F1	E0, E1, E2	Door switch malfunction.	Function not used.
	E3, or E4	Electronic control malfunction.	Replace control.
F2	E0 or E1	Keypad not connected.	Check keypad connector for firm connection.
	E3	Keypad held down too long, or keypad is shorted.	Press CANCEL if error code returns after 60 seconds, then replace keypad.
F3	E0	Control board resistor opened.	Check resistor in harness bet ween P5-8 to P5-9. Resistance should measure between 1000 Ω and 1852 Ω . If not in this range, replace the harness.
	E1	Control board resistor shorted.	
	E2	Convection sensor malfunction.	Check the resistance of the convection sensor. It should measure: Room Ambient: 15°C (59°F) 20°C (68°F) 25°C (77°F) 30°C (86°F) Resistance (KΩ): 294.7 - 471.2 233.2 - 366.9 185.7 - 287.7 148.8 - 227.2 If this range is not within limits, replace the convection sensor.
F4	E0	Meat probe shorted.	Function not used. Check harness connection.
F8	E0	Self-clean latch will not lock.	Function not used.
	E1	Self-clean latch will not unlock.	
All Other Codes		Electronic control malfunction.	Replace control.

COMPONENTS THAT CAN BE TESTED AT THE CONTROL PANEL

COMPONENT	FRONT / REAR SERVICEABLE	CHECK POINTS	RESULTS
Blower (Low Speed)	Rear	P7-6 (VT) to Neutral (W)	10 Ω to 15 Ω
Microwave Light Transformer	Front	Primary Winding	40 Ω TO 45 Ω
		Secondary Winding	Less than 1 Ω

COMPONENT	FRONT / REAR SERVICEABLE	CHECK POINTS	RESULTS
Convection Element (M/W)	Rear	P8-3 (BR) to Neutral (W)	10 Ω TO 20 Ω
Convection Fan (M/W)	Rear	P10-3 (Y) to Neutral (W)	44 Ω

ELECTRONIC OVEN CONTROL PINOUTS

NOTE: The input and output pins for the lower oven functions are not used.

PIN	FUNCTION	COLOR
CONTROL BOARD POWER 0.045" SQUARE POST		
P15-1	L1 > CONTROL	BK
P15-2	NO PIN	-
P15-3	EARTH GROUND	GN
P15-4	NO PIN	-
P15-5	NEUTRAL	W
PC BOARD TRANSFORMER 0.045" SQUARE POST		
P17-1	15	Y
P17-2	16	Y
P17-3	17	TAN
P17-4	18	TAN
P17-5	13	VT
P17-6	14	VT
P17-7	NO PIN	-
P17-8	8 (L1)	BK
P17-9	NO PIN	-
P17-10	11 (NEUTRAL)	W
CONVECTION TEMPERATURE SENSOR		
P14-1	CONVECTION TEMPERATURE SENSOR	R
P14-2	CONVECTION TEMPERATURE SENSOR	W
LOWER OVEN BAKE AND BROIL ELEMENT CONNECTOR		
P2-1	OUTER BROIL	-
SPACE	-	-
P2-2	NO PIN	-
P2-3	L1 > OUT BROIL/BAKE	-
P2-4	BAKE	-

PIN	FUNCTION	COLOR
LOWER OVEN CONVECTION RING AND INNER BROIL ELEMENT CONNECTOR		
P3-1	INNER BROIL	-
CIR POST	-	-
P3-2	L1 > INNER BROIL	-
P3-3	L1 > CONV RING	-
P3-4	CONVECTION RING	-
LOWER OVEN LOW VOLTAGE 0.045" SQUARE POST		
P5-1	+5 SWITCH PULSE	-
P5-2	NO PIN	-
P5-3	DOOR SWITCH	-
P5-4	MEAT PROBE	-
P5-5	MEAT PROBE CHASSIS GROUND	-
P5-6	LATCH SWITCH	-
P5-7	GROUND	GN
P5-8	OVEN SENSOR	1000 Ω - 1852 Ω RESISTOR
P5-9	OVEN SENSOR	1000 Ω - 1852 Ω RESISTOR
P5-10	CAVITY SELECT	-
LOWER OVEN HIGH VOLTAGE 0.045" SQUARE POST		
P7-1	L1 FOR LIGHTS, FANS AND LATCH	BK
P7-2	LOWER OVEN LIGHTS	-
P7-3	LOWER OVEN LATCH SOLENOID	-
P7-4	NO PIN	-
P7-5	LOWER OVEN BLOWER - HI	-

PIN	FUNCTION	COLOR
P7-6	UPPER OVEN BLOWER	VT
P7-7	LOWER OVEN CONVECTION FAN	-
P7-8	NO PIN	-
MICROWAVE OVEN L1 AND MAGNETRON CONNECTOR		
P8-1	DOOR CLOSED L1 > MAG	BK
CIR POST	-	-
P8-2	MAGNETRON	R
P8-3	CONV. ELEM.	BR
P8-4	DOOR CLOSED L1 > CONV	BK
MICROWAVE OVEN L2, GRILL AND CONVECTION ELEMENT CONNECTOR		
P9-1	L2 > GRILL	R
RECT POST	-	-
P9-2	NO PIN	-
P9-3	GRILL ELEMENT	BU
P9-4	NO PIN	-
MICROWAVE HIGH VOLTAGE 0.045" SQUARE POST		
P10-1	DOOR OPEN L1 > LIGHTS	BR
P10-2	TURNTABLE/FAN	BU
P10-3	CONV. FAN AIR VENT SOL.	Y
P10-4	MICROWAVE FUSED L1 > TT/FAN	BK
MICROWAVE HARNESS CONNECTOR - J1		
J1-1	L1 > MICROWAVE FUSE	BK
J1-2	N > CONV. ELEMENT/FAN, AIR VENT SOL.	W
J1-3	L2 > GRILL	R
J1-4	N > MAG/FAN/TT	W
J1-5	LIGHT XFMR PRIMARY	BK
J1-6	N > GRILL	W

MICROWAVE OVEN POWER OUTPUT TEST

The power output of the magnetron can be measured by the following test: (for accurate results, the line voltage must be 120 VAC and the oven cavity must be clean).

1. Fill a glass measuring cup with 16 oz. (453 cc) of tap water. Stir the thermometer through the water until the temperature stabilizes.
2. Place the cup of water in the center of the oven. Operate on HIGH for 60 seconds.
3. Stir the thermometer through the water and record the maximum temperature.
4. Subtract the cold water temperature from the hot water temperature. The normal result should be a 20 - 38° F (11.1 - 21.1° C) rise in temperature.

NOTE: Less than a 20° F (11.1° C) temperature rise may indicate an operating voltage of less than 110 volts or a low power output from the magnetron. Cooking time can be adjusted to compensate for either circumstance. Replace the magnetron only if the water temperature rise indicates a power output well beyond the normal result.

MICROWAVE OVEN RELAY LOGIC

MODES	RELAYS MAG.	GRILL	CONV	CONV FAN	MAG FAN	LIGHT	UPPER BLOWER	LOWER BLOWER
MICRO. FULL PWR	X	O	O	O	X	X	X	X
MICRO. VAR. PWR	△	O	O	O	X	X	X	X
BROIL	O	X	O	O	X	X	X	X
MANUAL CRISP	△	X	O	O	X	X	X	X
OFF	O	O	O	O	X	X	X	X
CONV. PREHEAT	O	△	X	X	O	X	X	X
CONV. COOK	O	O	△	X	O	X	X	X

RELAY LOGIC KEY

O – OFF

X – ON

△ – CYCLING (MAX. PERIOD = 23 SEC.)

⊗ – ON OR OFF

TROUBLESHOOTING CHART

PROBLEM	CAUSE
<p>The microwave oven will not run.</p>	<ul style="list-style-type: none"> • The door is not firmly closed and latched. • The EASY MINUTE START keypad was not touched. • The directions were not exactly performed. • An earlier programmed operation is still running. • The numbers after touching MICRO COOK were not entered.
<p>Microwave cooking times seem too long.</p>	<ul style="list-style-type: none"> • The electrical supply to the wall outlets is low, or is lower than normal. Check to find out if the line voltage is low. • The COOK POWER is not at the recommended setting. • Larger amounts of food need longer cooking times.
<p>The turntable will not turn.</p>	<ul style="list-style-type: none"> • The turntable is not correctly in place. Make sure that the turntable has the correct-side facing up and is sitting securely on center spindle. • The support is not operating correctly. Remove the turntable, check that the turntable spindle is properly in place, and restart the oven.
<p>The display shows a time counting down, but the oven is not cooking.</p>	<ul style="list-style-type: none"> • The oven door is not closed completely. • The control is set as a kitchen timer. Touch OFF/CANCEL to cancel the Minute Timer.
<p>The programming tone cannot be heard.</p>	<ul style="list-style-type: none"> • The tones have been disabled. Refer to the “Use and Care Guide” for the procedure on setting the tones.
<p>Smoke is coming out of the vent during broiling.</p>	<ul style="list-style-type: none"> • This is normal.
<p>“F” followed by a number appears on Display.</p>	<ul style="list-style-type: none"> • A command keypad failure has occurred.

If none of the items above is causing the problem, refer to “Requesting Assistance or Service” on page 6-1. Touch Number keypad 1 to clear any failure codes from the Display.

WIRING DIAGRAMS & STRIP CIRCUITS

WIRING DIAGRAM

Models KBHC109J & KBHC179J

WIRE HARNESS SCHEMATIC

NOTES:

DOTS INDICATE CONNECTIONS OR SPLICES.

CIRCUIT SHOWN IN STANDBY/OFF MODE WITH MICROWAVE OVEN DOOR OPEN.

LOWER OVEN INPUTS AND OUTPUTS NOT USED.

T.O.D. (RESETTABLE)		LIGHT		HEATING ELEMENT	
THERMAL FUSE T.O.D. (NON-RESETTABLE ONE TIME)		AC DRIVE MOTOR		SOLENOID	
GROUND (CHASSIS)		RELAY COIL		ENCLOSED THERMISTOR	
PLUG WITH FEMALE CONNECTOR		RELAY CONTACTS		OPERATED BY DOOR	
RECEPTACLE WITH MALE CONNECTOR					

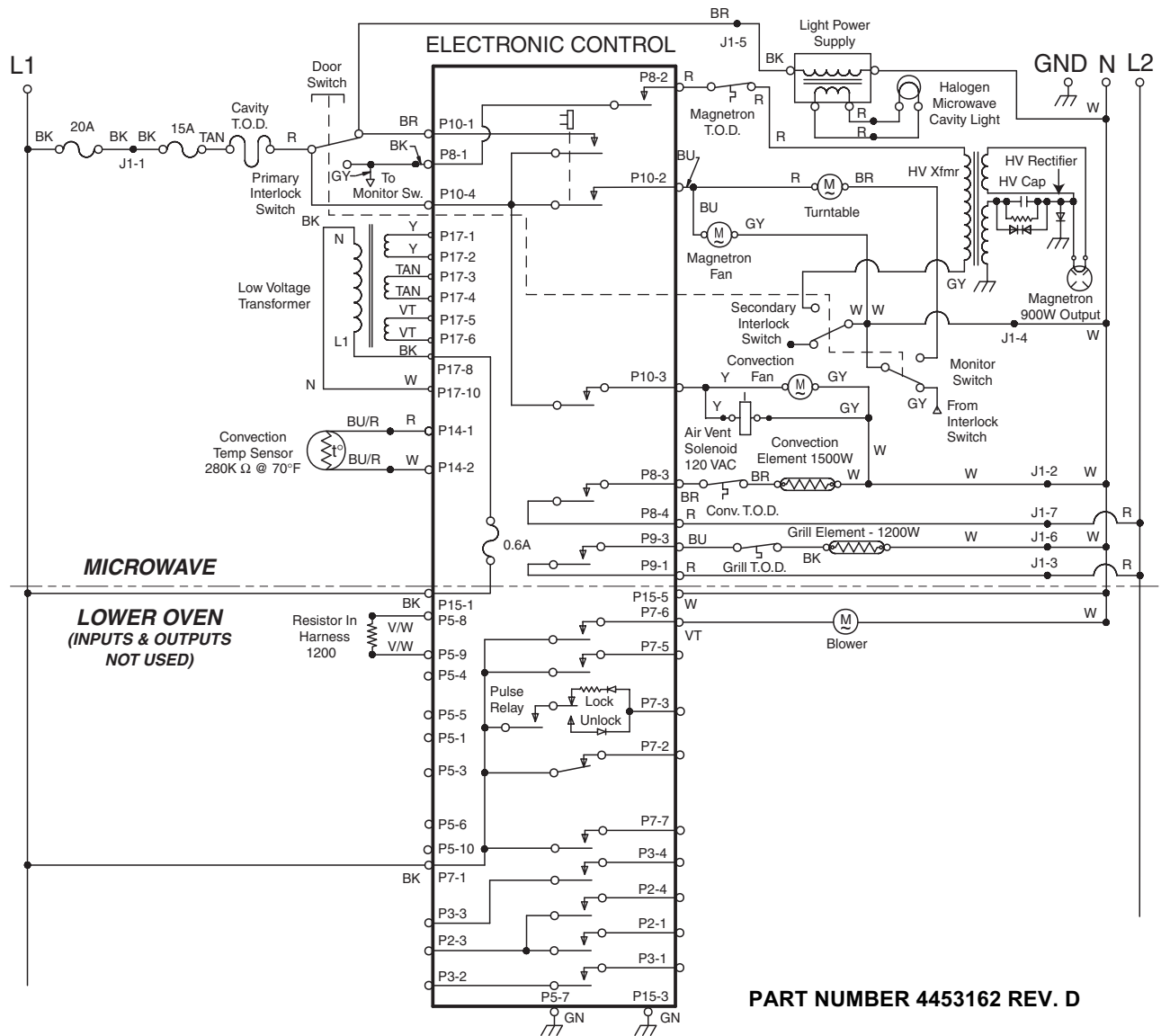

PART NUMBER 4453162 REV. D

WIRING DIAGRAM

Models KBMC140H & KBMC147H

WIRE HARNESS SCHEMATIC

NOTES:

- DOTS INDICATE CONNECTIONS OR SPLICES.
- CIRCUIT SHOWN IN STANDBY/OFF MODE WITH MICROWAVE OVEN DOOR OPEN.
- LOWER OVEN INPUTS AND OUTPUTS NOT USED.

T.O.D. (RESETTABLE)		LIGHT		HEATING ELEMENT	
THERMAL FUSE T.O.D. (NON-RESETTABLE ONE TIME)		AC DRIVE MOTOR		SOLENOID	
GROUND (CHASSIS)		RELAY COIL		ENCLOSED THERMISTOR	
PLUG WITH FEMALE CONNECTOR		RELAY CONTACTS		OPERATED BY DOOR	
RECEPTACLE WITH MALE CONNECTOR					

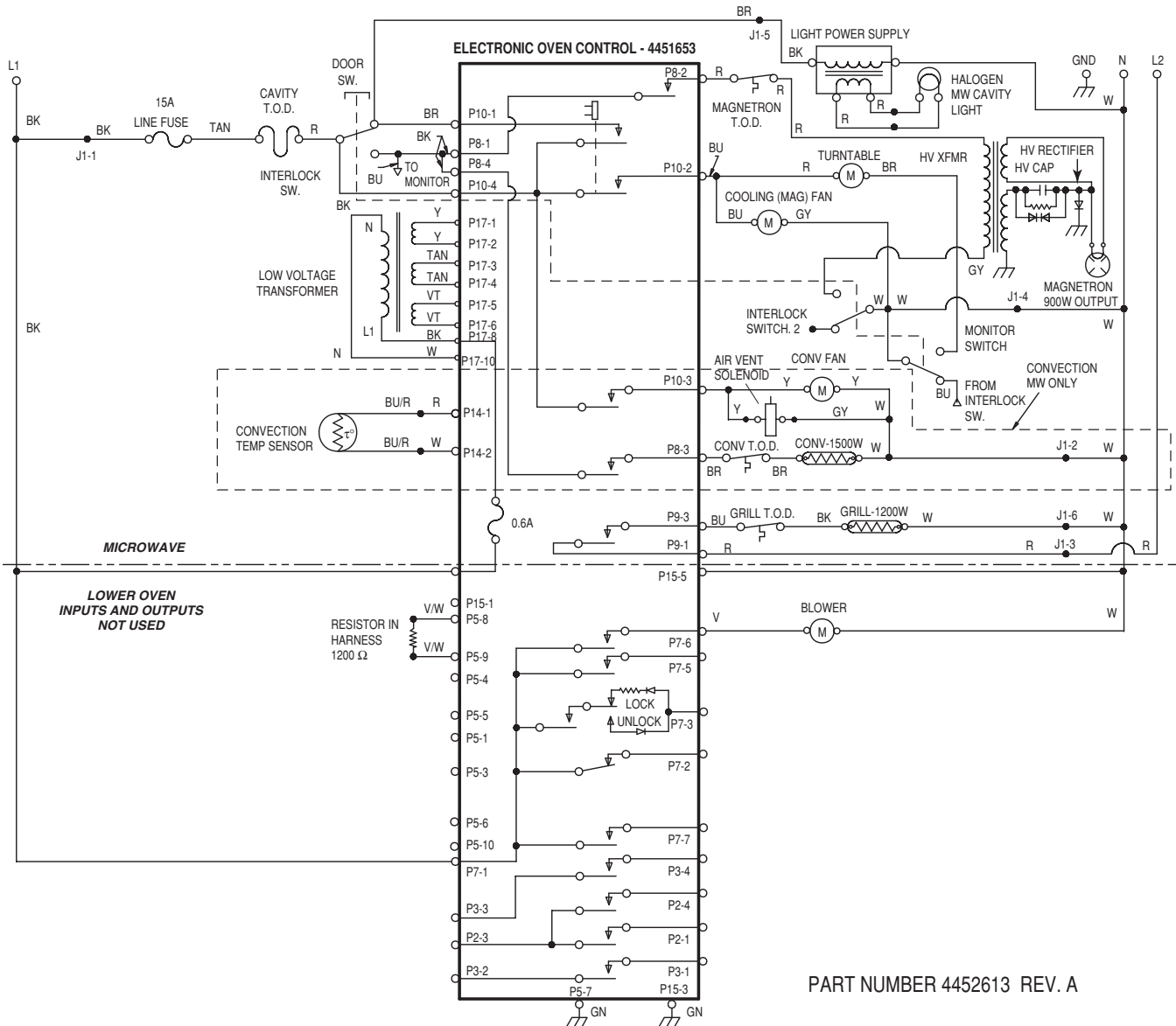

PART NUMBER 4452613 REV. A

STRIP CIRCUITS

Models KBMC140H & KBMC147H

MICROWAVE FULL POWER / MICROWAVE VARIABLE POWER

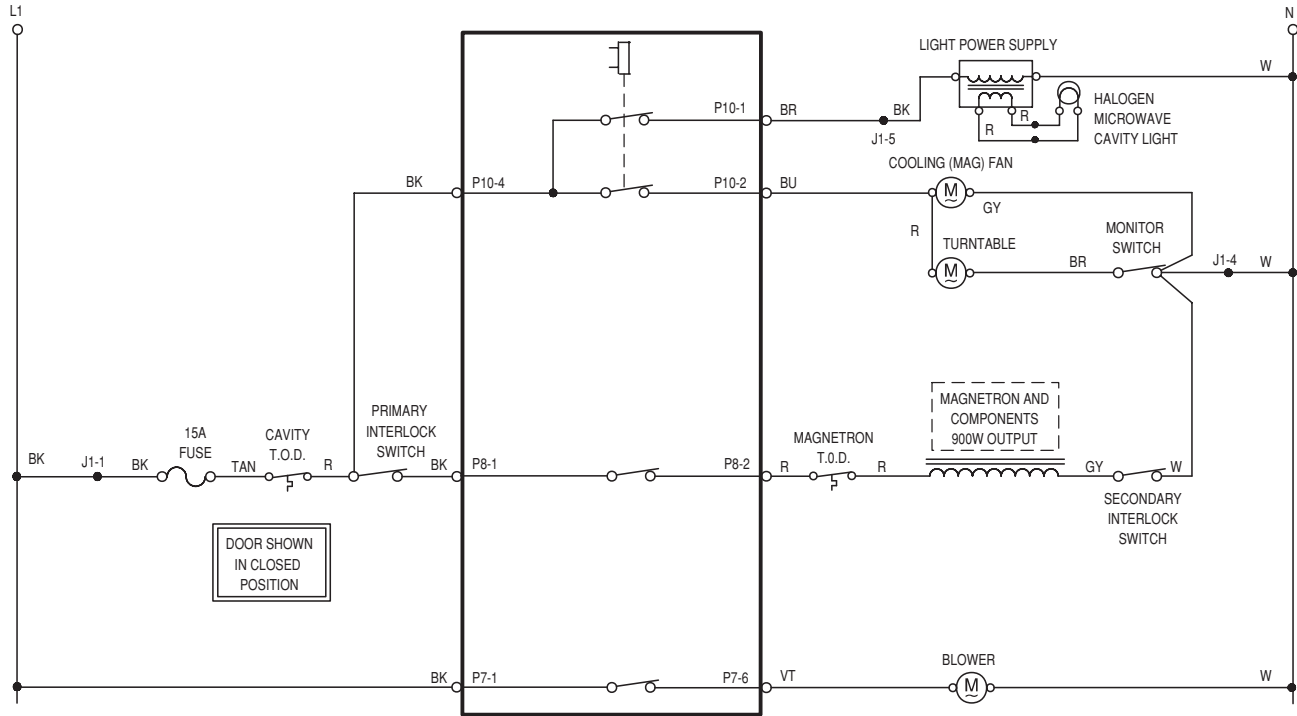

BROIL (NO MICROWAVE ENERGY)

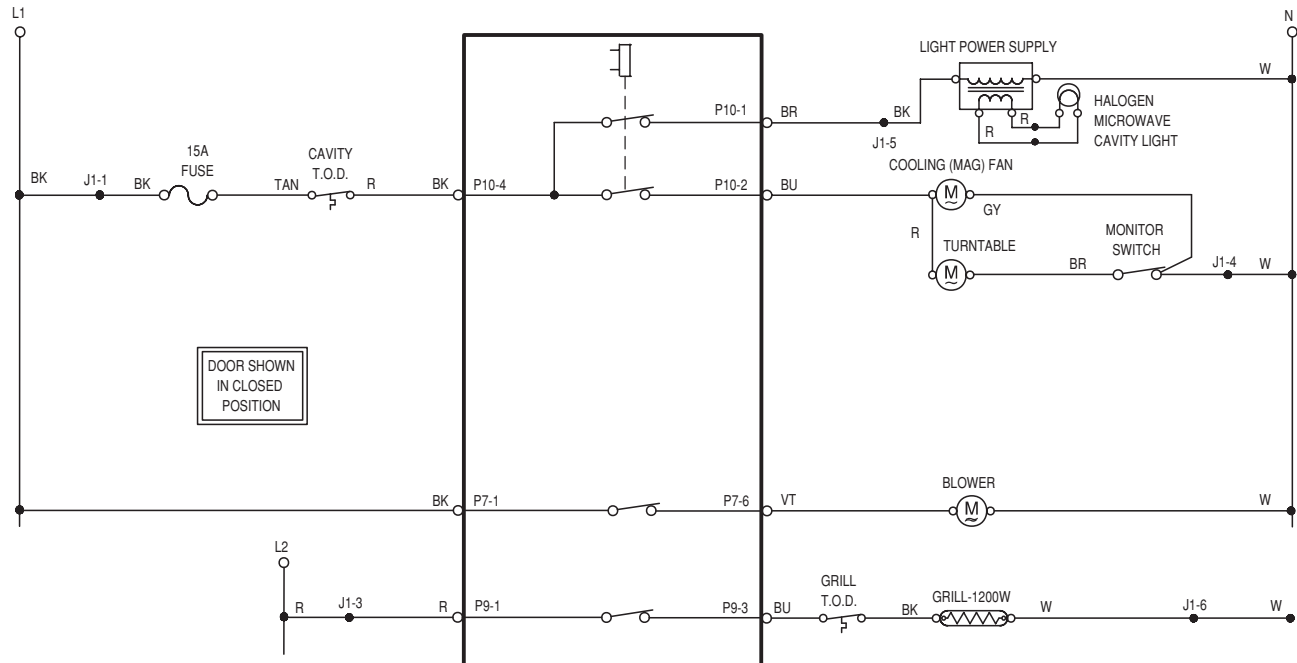

MICROWAVE MANUAL CRISP

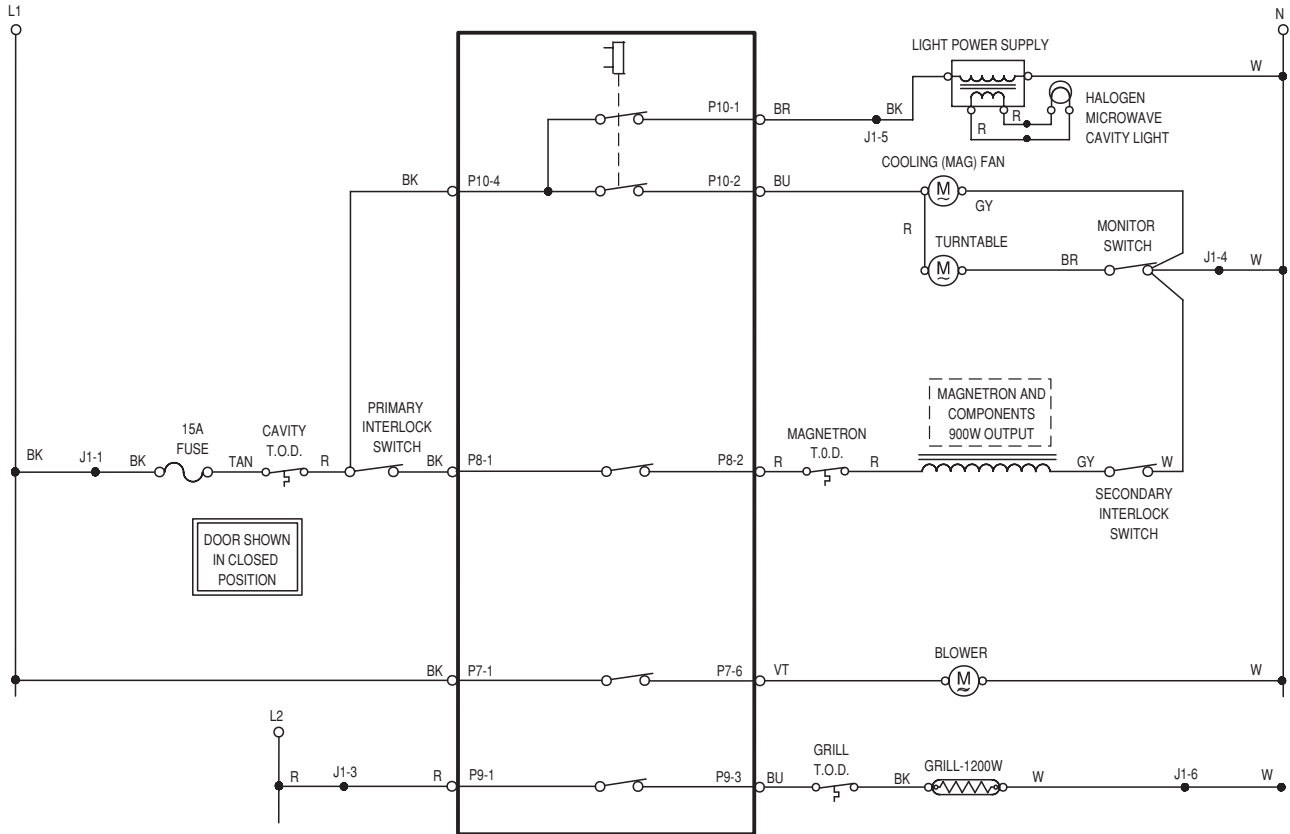

CONVECT (FOR MICROWAVE)

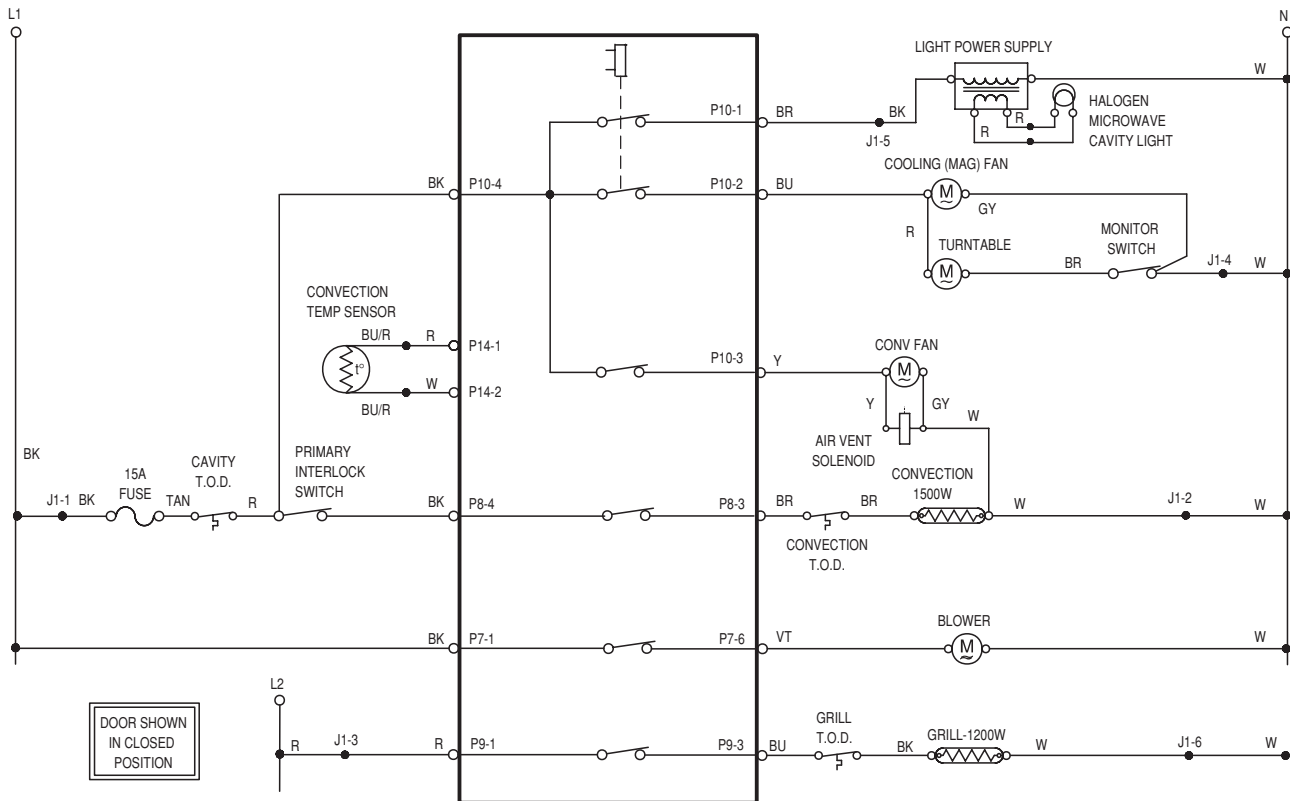

TECH TIPS

REQUESTING ASSISTANCE OR SERVICE

If you need assistance or service in the U.S. A.:

Call the KitchenAid Consumer Assistance Center toll free, at

1-800-422-1230

If you need assistance or service in Canada:

Call the Inglis Limited Consumer Assistance Center telephone number toll-free, 8:30 a.m. to 6:00 p.m. (EST) at:

1-800-461-5681.

Our consultants are available to assist you.

When calling, please have the purchase date, and the complete model and serial number of your appliance handy. This information will help with your request.

Our consultants provide assistance with:

- Features and specifications on our full line of appliances.
- Installation information.
- Use and maintenance procedures.
- Accessory and repair parts sales.
- Specialized customer assistance (Spanish & French (Canada) speaking, hearing impaired, limited vision, etc.).
- Referrals to local dealers, service companies, and repair parts distributors.

KitchenAid service technicians are trained to fulfill the product warranty and provide after-warranty service, anywhere in the United States and Canada. To locate the authorized KitchenAid service company in your area, you can also look in your telephone directory Yellow Pages.

If you need to order replacement parts, we recommend that you only use factory authorized parts. These parts will fit right and work right, because they are made with the same precision used to build every new KitchenAid appliance.

To locate factory authorized replacement parts in your area, call our Consumer Assistance Center telephone number or your nearest authorized service center.

If you need further assistance, you can write to KitchenAid with any questions or concerns at:

KitchenAid Brand Home Appliances
Consumer Assistance Center
c/o Correspondence Dept.
2000 North M-63
Benton Harbor, MI 49022-2692

In Canada, contact:

Consumer Relations Department
KitchenAid Canada
1901 Minnesota Court
Mississauga, Ontario L5N 3A7

Please include a daytime phone number in your correspondence.

KITCHENAID BUILT-IN MICROWAVE WARRANTY

LENGTH OF WARRANTY:	KITCHENAID WILL PAY FOR:	KITCHENAID WILL NOT PAY FOR:
<p>ONE-YEAR FULL WARRANTY From Date of Purchase.</p>	<p>Replacement parts and repair labor costs to correct defects in materials or workmanship. Service must be provided by a KitchenAid designated servicing company.</p>	<p>A. Service calls to:</p> <ol style="list-style-type: none"> 1. Correct the installation of the microwave oven. 2. Instruct you how to use the microwave oven. 3. Replace house fuses or correct house wiring. <p>B. Repairs when oven is used in other than normal single-family household use.</p>
<p>SECOND-THROUGH FIFTH-YEAR LIMITED WARRANTY From Date of Purchase.</p>	<p>Replacement parts for microwave magnetron or any oven electric element to correct defects in materials or workmanship. Replacement parts for solid state touch control system to correct defects in materials or workmanship.</p>	<p>C. Damage resulting from accident, alteration, misuse, abuse, fire, flood, acts of God, improper installation, installation not in accordance with local electrical codes, or use of products not approved by KitchenAid.</p> <p>D. Any labor costs during the limited warranties.</p> <p>E. Replacement parts or repair labor costs for units operated outside the United States or Canada.</p> <p>F. Pickup and delivery. This product is designed to be repaired in the home.</p> <p>G. Repairs to parts or systems resulting from unauthorized modifications made to the appliance.</p> <p>H. In Canada, travel or transportation expenses for customers who reside in remote areas.</p>
<p>SECOND-THROUGH TENTH-YEAR LIMITED WARRANTY From Date of Purchase.</p>	<p>Replacement parts for the stainless steel oven cavity/ inner door if the part rusts through due to defects in materials or workmanship.</p>	

KITCHENAID AND KITCHENAID CANADA DO NOT ASSUME ANY RESPONSIBILITY FOR INCIDENTAL OR CONSEQUENTIAL DAMAGES. Some states or provinces do not allow the exclusion or limitation of incidental or consequential damages, so this exclusion or limitation may not apply to you. This warranty gives specific legal rights and you may also have other rights which vary from state to state or province to province.

Outside the United States and Canada, a different warranty may apply. For details, please contact your authorized KitchenAid dealer.

If you need assistance or service, first see the "Diagnosis & Troubleshooting" section of this book. After checking "Diagnosis & Troubleshooting," additional help can be found by checking the "Requesting Assistance or Service" section. In the U.S.A., call our Consumer Assistance Center at: **1-800-422-1230**. In Canada, call KitchenAid Canada at: **1-800-461-5681** or **1-800-807-6777**.

— NOTES —

— NOTES —