

# SERVICE MANUAL

*for the*



## 30" ELECTRIC MODULAR DOWNDRAFT COOKTOP

THIS MANUAL CONTAINS INFORMATION NECESSARY FOR INSTALLING AND SERVICING THE FOLLOWING WHIRLPOOL 30" ELECTRIC MODULAR DOWNDRAFT COOKTOP, MODEL:

RC8700ED  
RC8720ED

THE MANUAL IS DESIGNED TO BE USED ONLY BY QUALIFIED SERVICE PERSONNEL. THE SERVICE INFORMATION IS ORGANIZED TO HELP YOU EASILY FIND WHAT YOU NEED.

CHECK YOUR LOCAL BUILDING CODE FOR THE PROPER MODE OF INSTALLATION. IN THE ABSENCE OF LOCAL CODES, THIS UNIT SHOULD BE INSTALLED IN ACCORDANCE WITH THE *NATIONAL ELECTRICAL CODE, ANSI/NFPA NO. 70 - 1990, OR C22.1 CANADIAN ELECTRICAL CODE, PART 1.*



## Table of Contents

	<b>Page</b>
Important Safety Information .....	iv
Installation Highlights .....	1-1
Before You Start .....	1-1
Cooktop Dimensions .....	1-1
Cutout Dimensions .....	1-2
Clearance Dimensions .....	1-2
Tools & Material You Will Need .....	1-3
Venting Requirements .....	1-4
Installing The Cooktop .....	1-10
Electrical Supply Requirements .....	1-11
Electrical Connections .....	1-12
Venting Operation Check .....	1-15
Theory Of Operation .....	2-1
The Coil Elements .....	2-1
The Radiant Elements .....	2-2
The Grill Elements .....	2-3
The Fan Motor .....	2-4
Component Access .....	3-1
Cooktop Components .....	3-1
Component Locations .....	3-1
Removing The Control Panel & The Surface Unit Indicator Light .....	3-2
Removing The Control Switch .....	3-3
Removing The Maintop .....	3-4
Removing The Cooktop .....	3-4
Removing A Terminal Block .....	3-6
Removing The Fan Motor .....	3-7
Module Components .....	3-8
The Ceramic Surface Unit RCM30DB/Q — Removing The Glass, Element, Or Limiter .....	3-8
The Coil Surface Unit RCM10DB/Q — Removing A Coil Element & Connector .....	3-10
The Grill RCM20DB — Removing The Grill Element .....	3-12
Removing A Terminal Plug Connector .....	3-13
Component Testing .....	4-1
Troubleshooting .....	4-1
Tech Tips .....	5-1
Schematic Diagram — Model RC8700ED .....	5-1
Wiring Diagram— Model RC8700ED .....	5-2
Schematic Diagram — Model RC8720ED .....	5-3
Wiring Diagram— Model RC8720ED .....	5-4
Strip Circuits .....	5-5
Specifications .....	5-6
Model Number Designation .....	5-10
30" Electric Modular Downdraft Cooktop Warranty .....	5-11

## IMPORTANT SAFETY INFORMATION

This service manual is intended for factory-service technicians only. We recommend that customers DO NOT service their own units, because of the complexity and risk of high-voltage electrical shock.

The following information is used throughout this manual, and should be read carefully.

### CAUTION

Information that will help you avoid actions that could cause product damage (scratches, dents, etc.) and damage to personal property.

### WARNING

Information that alerts you to potentially dangerous conditions. These conditions can cause serious personal injury (burns, fire and electrical shock, etc.) if the suggested procedures are not observed.

## WARNING

### Fire Hazard

Do not obstruct the flow of combustion and ventilation air.

### Electrical Shock Hazard

*It is the customer's responsibility to:*

- Contact a qualified electrical installer.
- Assure that electrical installation is adequate and in conformance with the National Electrical Code, ANSI/NFPA 70—latest edition\*, and all local codes and ordinances.
- Take special care when drilling holes into the wall for venting or electrical wiring. Electrical wires may be concealed behind the wall covering.
- Disconnect the power to any electrical circuits that could be affected by the installation of this cooktop.

Failure to do so could result in fire, electrical shock, or other personal injury.

### Personal Injury Hazard

To eliminate the risk of burns or fires, do not install cabinets or store things above the cooktop. If cabinets are already installed above the cooktop, install a range hood to the bottom of the cabinet to prevent reaching over the heated cooking surface. The range hood should stick out a minimum of 5-inches (12.7 cm) from the front of the cabinets.

Reaching over a heated cooking surface could result in a serious burn or other injury.

\* Copies of the standards listed above may be obtained from:

National Fire Protection Association  
Batterymarch Park  
Quincy, Massachusetts 02269

# INSTALLATION HIGHLIGHTS

## BEFORE YOU START

Proper installation is your responsibility. Make sure that you have everything necessary to properly install the cooktop. It is the responsibility of the installer to comply with the installation clearances specified on the model/serial rating plate. This plate is located on the left side of the cooktop's plenum.

The location where the cooktop is installed should be away from strong draft areas, such as windows, doors, and strong heating vents or fans.

The venting duct must terminate outdoors. All openings in the wall or floor where the cooktop is to be installed must be sealed.

This appliance is not approved for use in mobile homes.

## COOKTOP DIMENSIONS

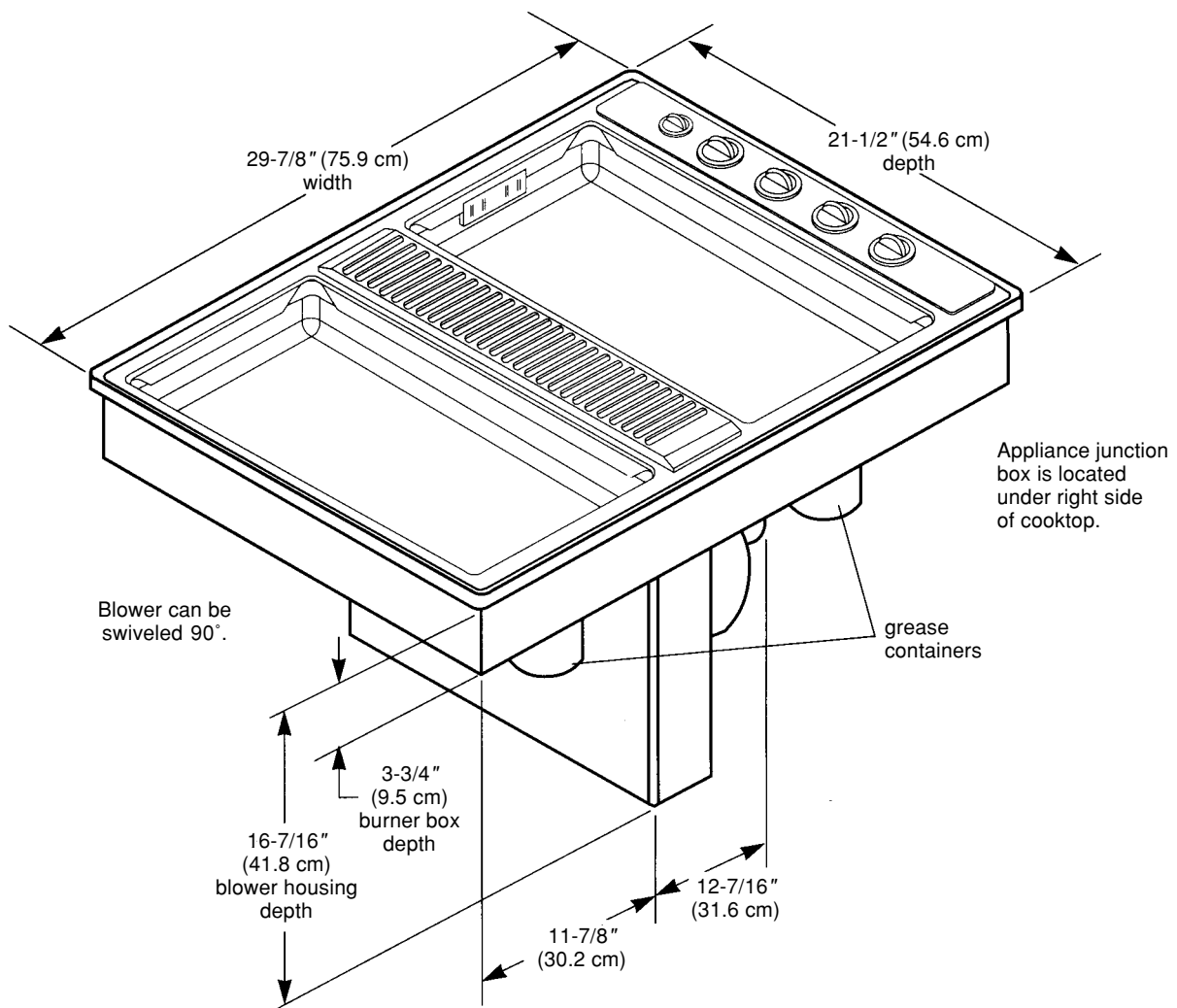

# CUTOUT DIMENSIONS

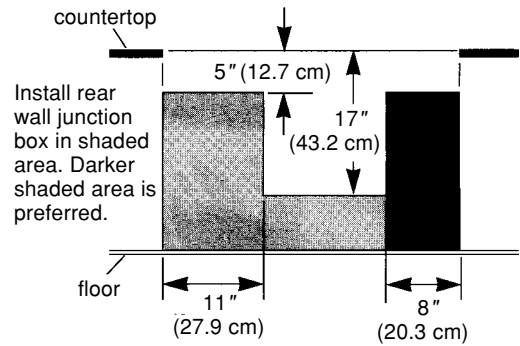
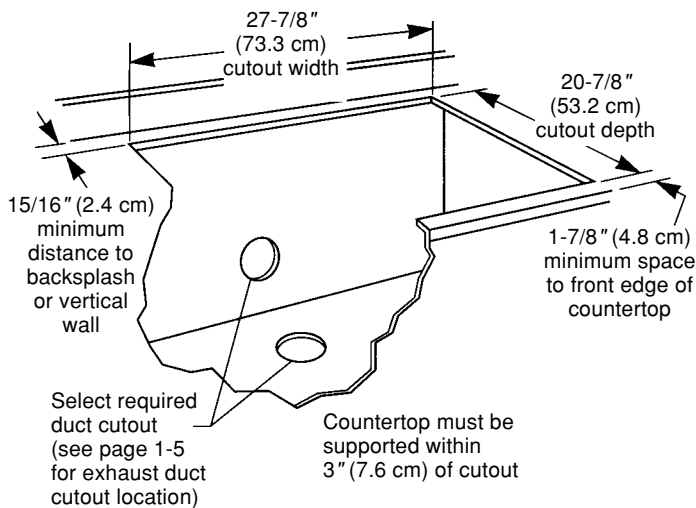

## Minimum Base Cabinet Dimensions:

- 30" (76.2 cm) base cabinet
- 24" (61.0 cm) base cabinet depth
- 25" (63.5 cm) countertop depth

## Cutout Preparation:

- Decorative laminate —
- Chamfer all exposed edges to prevent chipping laminate.
- Cut radius corners and file to smooth edges to prevent cracking.

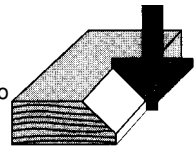

# CLEARANCE DIMENSIONS

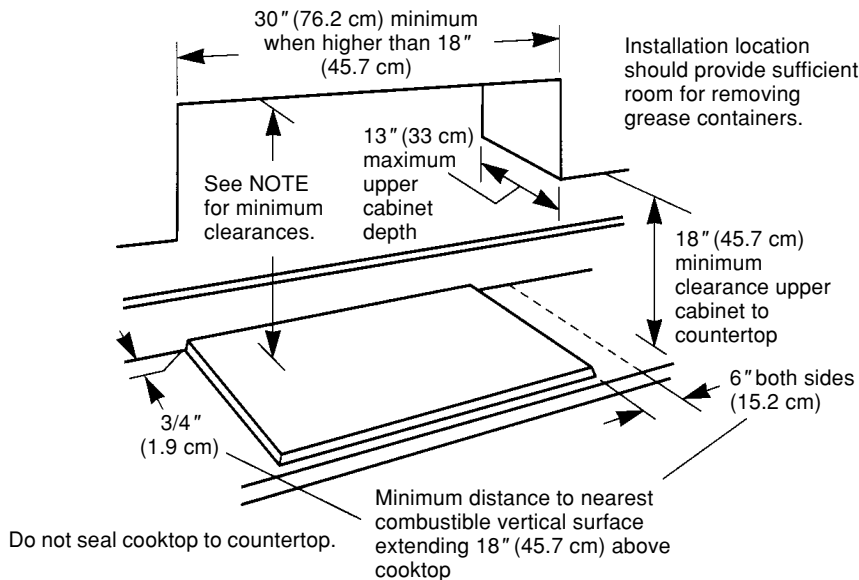

**Side Clearance:** 6" (15.2 cm) minimum clearance between side of cooktop and side wall is recommended for maximum ventilation performance.

**Rear Clearance:** 3/4" (1.9 cm) clearance between rear edge of appliance and rear wall is required.

**Motor/Blower Clearance:** 2" (5.1 cm) minimum clearance between motor and cabinet is required for proper cooling. 6" (15.2 cm) clearance is recommended for servicing access.

NOTE: 24" (61.0 cm) minimum when bottom of wood or metal cabinet is protected by not less than 1/4" flame-retardant millboard covered with not less than #28 MSG sheet steel, 0.015" stainless steel, 0.024" aluminum, or 0.020" copper.  
30" (76.2 cm) minimum clearance between the top of the cooking platform and bottom of unprotected wood or sheet metal.

## TOOLS & MATERIAL YOU WILL NEED

### DESCRIPTION

Phillips screwdriver  
Metal cutters  
Gloves  
Caulk gun with weatherproof caulk  
Electric or hand drill  
Pliers  
Safety glasses  
Measuring tape  
Duct tape

### ILLUSTRATION

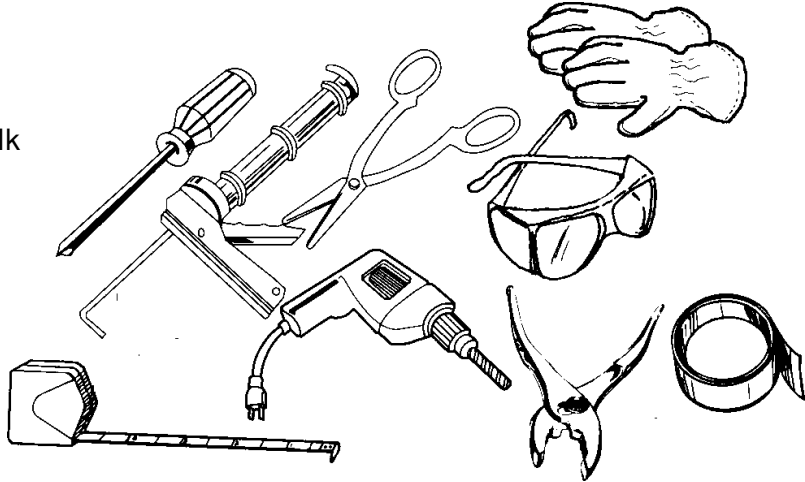

### **NOT SHOWN:**

Wall or roof cap  
Metal ductwork  
2 sheet metal screws to attach transition duct to venting adapter.  
Two U.L.-listed 1/2" conduit connectors.  
Flexible, armored, or nonmetallic sheathed copper cable (with grounding wire) that conforms to existing codes (see "Electrical Supply Requirements" on page 1-11).  
Twist-on connectors (number and size depends on installation).

## VENTING REQUIREMENTS

### **WARNING**

#### **Fire Hazard**

The venting system must terminate outdoors.

Do not end the ductwork in an attic, wall, ceiling, or other enclosed space.

Do not use 4" laundry-type wall caps.

Do not use plastic duct.

Do not block the flow of ventilation air.

Failure to follow these instructions could result in a fire.

**Before making any cutouts, make sure that there is proper clearance within the wall or floor for the exhaust duct. Do not cut a joist or stud unless it is absolutely necessary. If a joist or stud must be cut, a supporting frame must be constructed.**

This downdraft cooktop is rated for 60-feet of straight duct. If duct length is 10 feet (3 m) or less, 5" diameter round ductwork may be used. If duct length is more than 10 feet (3 m), use 6" diameter round or 3-1/4" x 10" rectangular duct.

**Thermal Breaks:** In areas of extreme cold weather, it may be necessary to provide a short length of nonmetallic duct as close to the wall as possible to prevent thermal conduction along the metal duct.

**High Altitudes:** For altitudes above 4,500 ft (1,350 m), reduce the recommended duct run by 20%.

For the quietest and most efficient operation:

- Use 26-gauge minimum galvanized, or 25-gauge minimum, aluminum metal duct. Poor-quality pipe fittings can reduce air flow. (Note: Local codes may require a heavier-gauge material.) Flexible metal duct is not recommended.
- Do not exhaust more than one downdraft cooktop into a single duct system.
- Keep the length of duct and number of elbows to a minimum.
- Keep the size of the duct uniform.
- Use no more than three 90° elbows.
- Do not install two elbows together.
- If more than one elbow is used, make sure that there is a minimum of 18" (45.7 cm) of straight duct between them. If elbows are too close together, they can reduce air-flow.
- Do not use a 5" elbow in a 6", or a 3-1/4" x10" system. Use a 5" to 6" transition followed by a 6" elbow, or a 5" to 3-1/4" x10" elbow transition.
- Do not reduce the duct work back to a 5" system after using 6", or 3-1/4" x10" fittings.
- Do not form handmade crimps. They can restrict airflow.
- Use recommended duct caps. If an alternate wall, or roof cap is used, be certain that the cap size is not reduced, and that it has a backdraft damper.
- Use duct tape to seal all joints in the duct system.
- Use weatherproof caulking to seal the exterior wall or roof opening around the cap.



Determine the best type of venting method to use. The cooktop can be vented through the rear wall, or through the floor. Common venting methods and the types of material needed

are shown below, and on the following page. Make sure that there is proper clearance within the wall or floor for the exhaust duct before making cutouts.

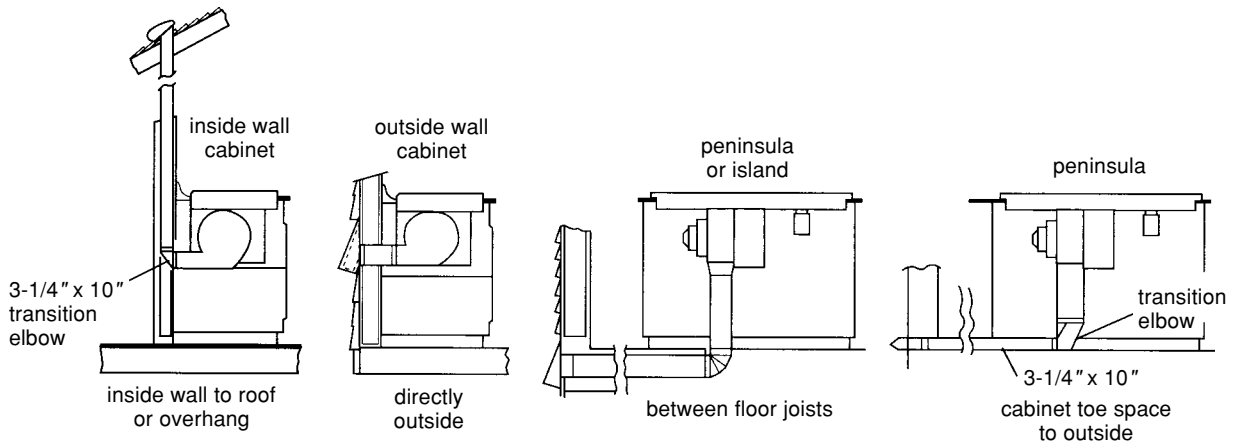
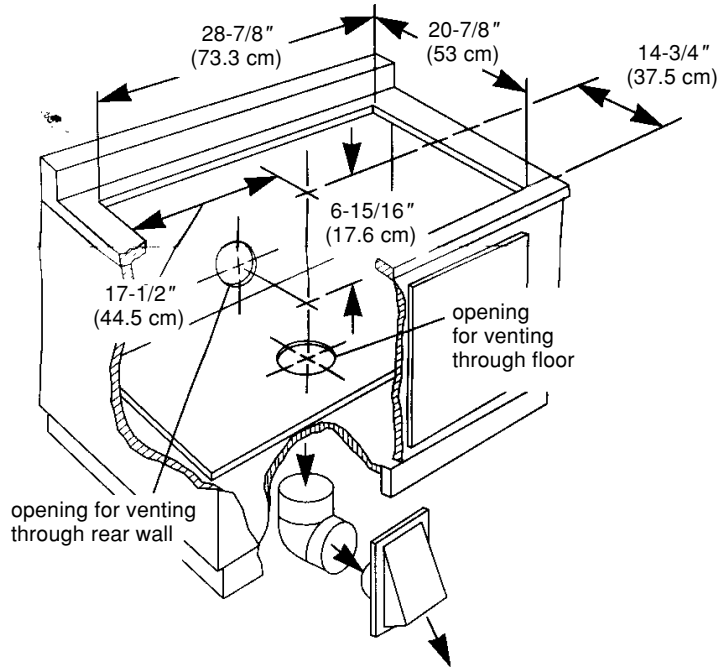

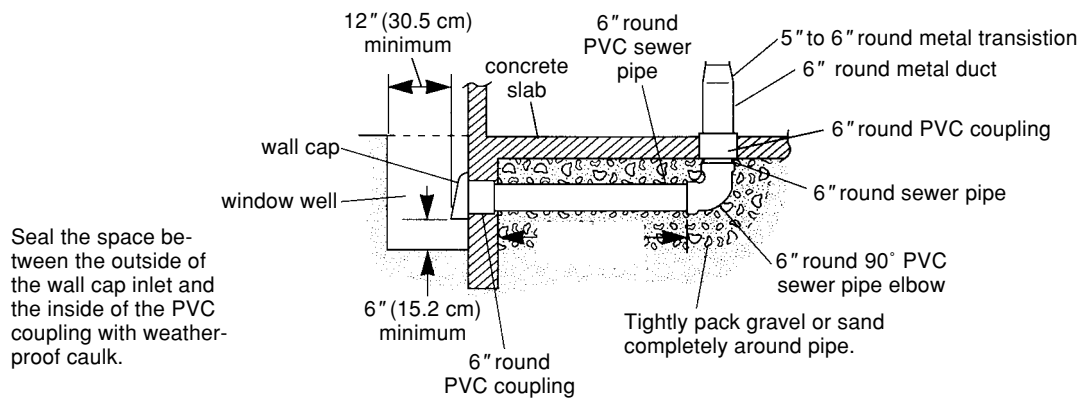

**Optional Duct Arrangement Through Window Well Under Concrete Slab**

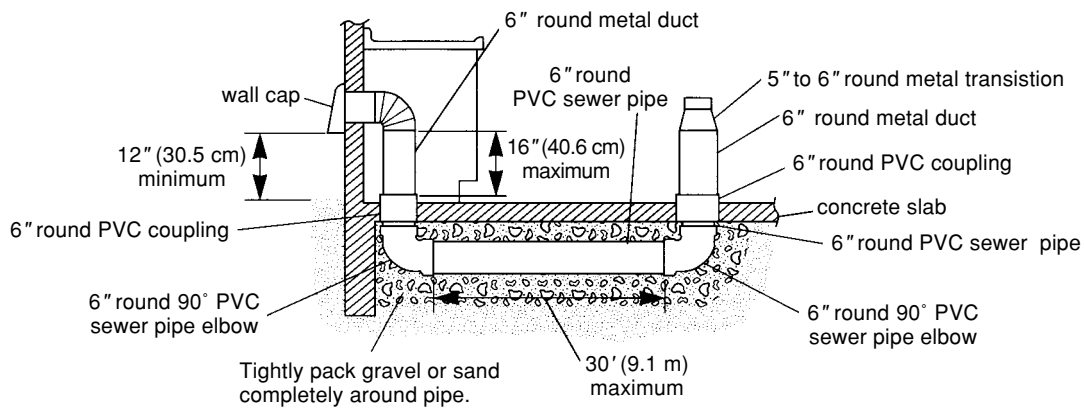















**Optional Duct Arrangement Under Concrete Slab**

## Chart

The cooktop is equipped with a dual-range blower. The blower is factory-set to operate at the "Low" range (equivalent duct lengths of 30-feet (9.1 m) or shorter. If the equivalent duct length exceeds 30-feet, the blower must be set to operate at the "High" range (see page 1-9). **Do not change the blower to "High" if the equivalent duct length is under 30-feet.** This will cause excessive noise and conditioned air loss.

To use the following chart, list the number of each piece, and the length of straight ductwork that you intend to use. Multiply the equivalent length by the number of pieces. Add the totals to get the total equivalent length of your duct system. Two duct system configuration examples are shown on the following page.

Duct Piece	Equivalent Length	No. of Pieces/Length	Total Equivalent Length
<b>straight duct per lineal foot</b>			
3-1/4" x 10"	1 ft. (30.5 cm)		
6" round	1 ft. (30.5 cm)		
6" flexible	2 ft. (61 cm)		
<b>elbow</b>			
 6" round 45° elbow	2.5 ft. (76 cm)		
 6" round 90° elbow	5 ft. (152 cm)		
 3-1/4" x 10" flat elbow	12 ft. (366 cm)		
 3-1/4" x 10" 90° elbow	5 ft. (152 cm)		
<b>transition to round</b>			
 5" to 6" air flow	1 ft. (30.5 cm)		
 3-1/4" x 10" to 6" 90° elbow air flow	9 ft. (274 cm)		
 3-1/4" x 10" to 6"	4.5 ft. (137 cm)		
<b>transition to flat</b>			
 5" to 3-1/4" x 10" 90° elbow air flow this direction not recommended air flow	6 ft. (183 cm)		
 6" to 3-1/4" x 10" 90° elbow air flow	5 ft. (152 cm)		
 6" to 3-1/4" x 10" air flow	1 ft. (30.5 cm)		
<b>wall cap*</b>			
 3-1/4" x 10"	0 ft. (0 cm)		
 5" or 6" round	0 ft. (0 cm)		
<b>roof cap*</b>			
 10" x 10"	0 ft. (0 cm)		
<b>thermal break</b>			
 5" or 6" round	2 ft. (61 cm)		
<b>Total equivalent duct system length</b>			

\* Length for required wall/roof cap has already been incorporated into rating for maximum duct system length. A suitable wall/roof cap must be used.

**6" Round Duct System Equivalent Length 30-feet (9.1 m) Or Less  
Set Blower To "Low" Range**

**Example:**

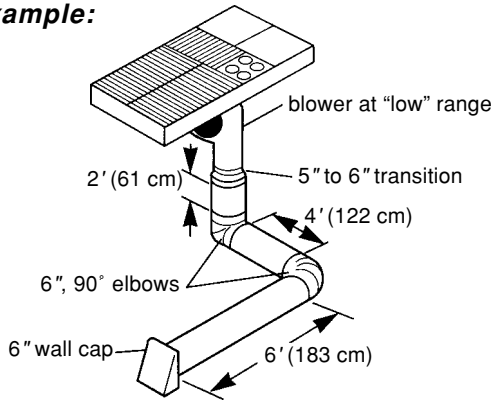

(2) 90° elbows	= 10 ft. (305 cm)
12' (366 cm) straight	= 12 ft. (366 cm)
5" to 6" transition	= 1 ft. (30.5 cm)
Wall cap	= 0 ft. (0 cm)

---

Total equivalent length = 23 ft. (701.5 cm)

Blower can be left at "low" range (factory setting).

NOTE: Flexible metal duct is not recommended. If it is used, calculate each foot as two feet of straight metal duct. Flexible metal elbows count twice as much as standard elbows.

**6" Round Duct System Equivalent Length Greater Than 30-feet (9.1 m)  
Set Blower To "High" Range**

**Example:**

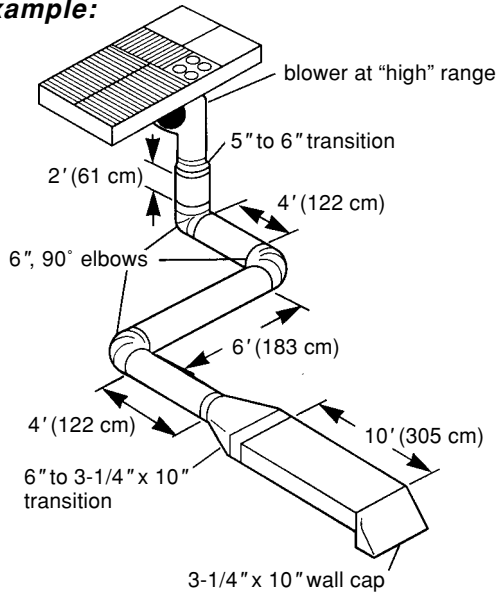

(3) 90° elbows	= 15 ft. (457.2 cm)
5" to 6" transition	= 1 ft. (30.5 cm)
6" to 3-1/4" x 10" transition	= 1 ft. (30.5 cm)
Wall cap	= 0 ft. (0 cm)
16' (488 cm) 6" straight	= 16 ft. (488 cm)
10' (254 cm) 3-1/4" x 10" straight	= 10 ft. (305 cm)

---

Total equivalent length = 43 ft. (1311.2 cm)

Blower must be set at "high" range by removing the restrictor ring (see page 1-9).

NOTE: Flexible metal duct is not recommended. If it is used, calculate each foot as two feet of straight metal duct. Flexible metal elbows count twice as much as standard elbows.

## CHANGING THE RANGE SETTING

**IMPORTANT NOTE:** This cooktop is equipped with a dual-range blower. The range is determined by a “restrictor ring” (see below) on the inlet of the blower. When the ring is installed, the blower is at the “low range” setting. When the ring is removed, the blower is at the “high range” setting. The blower is shipped from the factory with the restrictor ring installed. The “equivalent” duct length shown in the chart on page 1-7, (not the actual length), determines how the blower’s range should be set.

1. Determine the equivalent length of duct (see the chart on page 1-7). If the length is not more than 30-feet (9.1 m), leave the blower set at the current low range. If the duct length exceeds 30-feet, use the following procedure, and remove the restrictor ring from the blower (set it to the “high” range).

- a) Remove the air grille and filter from the blower housing.
- b) Press in on one of the spring clips that hold the restrictor ring to the blower inlet and pull the ring forward to remove it.
- c) Reinstall the filter and air grille.

2. Rotate the blower to the proper angle needed for your installation. The blower can be swiveled 90°. To rotate the blower:

- a) Remove the filter from the blower housing
- b) Loosen, but do not remove, the nuts around blower inlet.
- c) Rotate the blower housing for the proper angle.
- d) Retighten the four nuts and install the filter.

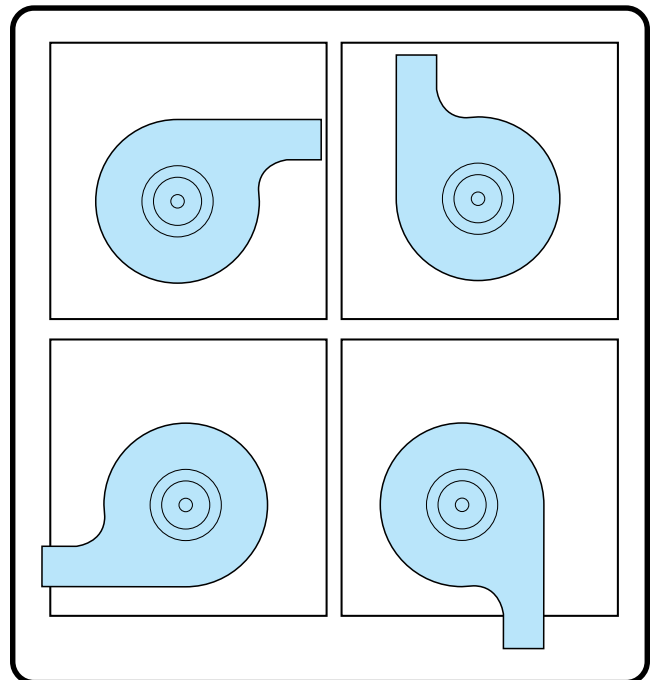
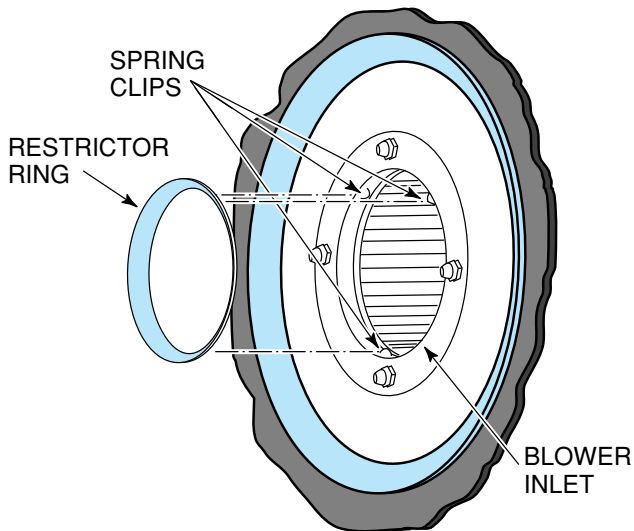
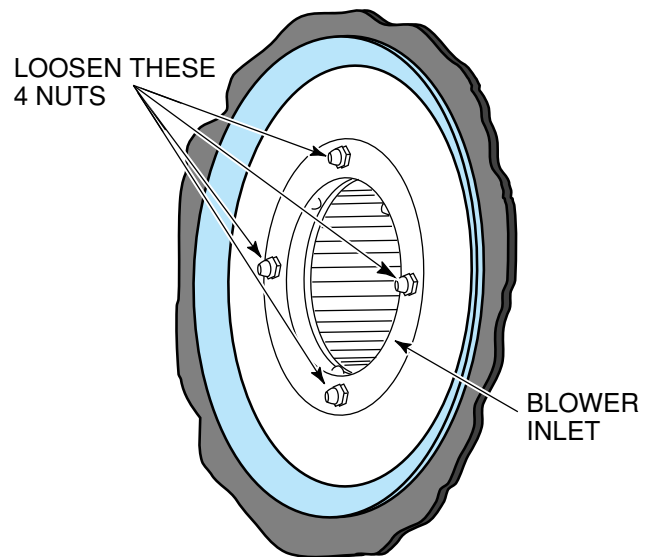

## INSTALLING THE COOKTOP

To install the cooktop, refer to the following steps.

1. Lift the cooktop from the shipping carton and remove the shipping materials, hardware package, and printed material.

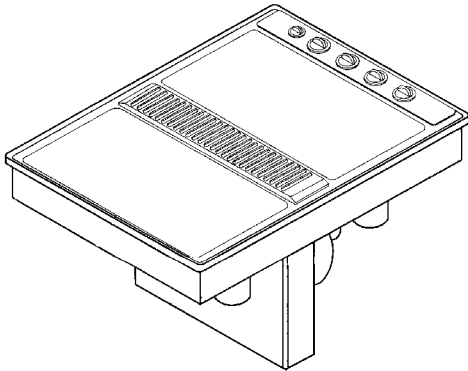

### CAUTION

#### Property Damage

Lift the entire cooktop from the cutout when repositioning the cooktop in the countertop opening.

Failure to do so could scratch the countertop.

2. Connect the duct system (if necessary, see pages 1-4 through 1-9 for ducting requirements).

NOTE: It may be easier to connect the cooktop power supply wiring before it is installed in the cabinet. If so, connect the conduit coming from the cooktop to the electrical junction box at this time (see pages 1-11 through 1-14). Otherwise, install the cooktop first, and then connect the electrical wiring.

3. Install the cooktop in the countertop cutout and center it. Make sure that the front edge of the cooktop is at least 1-1/2" (3.8 cm) from the front edge of the countertop, 3/4" (1.9 cm) from the rear wall, and at least 6" (15.2 cm) from the side wall.
4. If not already done, connect the conduit coming from the cooktop to the electrical junction box (see "Electrical Supply Requirements" on the following page).

## ELECTRICAL SUPPLY REQUIREMENTS

### **WARNING**

#### **Electrical Shock Hazard**

An electrical ground is required on this appliance.

If a cold water pipe is interrupted by plastic, nonmetallic gaskets, or other insulating materials, do not use for grounding.

Do not ground to a gas pipe.

Do not use a fuse in the neutral or grounding circuit. It could result in an electrical shock.

Check with a qualified electrician if you are in doubt as to whether the appliance is properly grounded.

Failure to follow these instructions could result in serious injury or death.

### **GENERAL**

If codes permit, and a separate grounding wire is used, it is recommended that a qualified electrician determine that the grounding path is adequate.

The following information applies to appliance and vent system wiring:

- A 3- or 4-wire, single phase, 120/240-volt, 60 Hz, AC-only electrical supply, or a 3- or 4-wire, 120/208-volt supply, if specified on the model/serial rating plate, is required on a separate 40-ampere circuit, fused on both sides of the line.

- A time-delay fuse, or circuit breaker, is recommended. The fuse must be sized as per local codes in accordance with the electrical rating of the appliance specified on the model/serial rating plate, which is located on the left side of the vent's plenum.
- The cooktop must be connected with copper wire only.
- Wire sizes and connections must conform to the requirements of the National Electrical Code, ANSI/NFPA 70—latest edition\*, and all local codes and ordinances. Wire sizes and connections must conform with the rating of the appliance. Copies of the standards listed above may be obtained from:

\* *National Fire Protection Association  
Batterymarch Park  
Quincy, Massachusetts 02269*

- The appliance should be connected directly to the fused disconnect (or circuit breaker) through flexible, armored, or nonmetallic sheathed, copper cable with grounding wire. The flexible, armored cable that extends from the appliance should be connected directly to the junction box.
- Locate the junction box to allow as much slack as possible between the junction box and the appliance so that the appliance can be moved if servicing is ever necessary. Do not cut the conduit.
- A U.L.-listed, 1/2" (1.3 cm) conduit connector must be provided at the junction box.
- A wiring diagram is located in the "Tech Tips" section of this manual.

## ELECTRICAL CONNECTIONS

### **WARNING**

#### **Electrical Shock Hazard**

An electrical ground is required on this cooktop.

Do not connect to the electrical supply until the cooktop is permanently grounded.

Disconnect power to the junction box before making the electrical connection.

This cooktop must be connected to a grounded, metallic, permanent wiring system, or a grounding connector should be connected to the grounding terminal or wire lead on the cooktop.

Failure to follow these instructions could result in death or serious injury.

This appliance is manufactured with a white (neutral) power supply wire and a cooktop-connected green (or bare) grounding wire twisted together.

An appliance cable and connectors are not provided.

To connect the cooktop power cable to the main power supply junction box:

1. Turn off the power to the main junction box.

2. Remove the junction box cover from the junction box inside the cabinet.
3. Remove the cooktop junction box cover located on the right side of the cooktop.
4. Use a U.L.-listed conduit connector to connect the appliance cable to the junction box inside the cabinet.
5. Remove the knockout on the side of the cooktop junction box that fits the size of the appliance cable.
6. Use a U.L.-listed conduit connector and connect the appliance cable to the cooktop junction box.

NOTE: When you connect the cable wires, together, hold the bare ends next to each other, and twist a wire connector over them.

7. Connect the two black wires together with twist-on connectors in both junction boxes.
8. Connect the two red wires together with twist-on connectors in both junction boxes.

Complete the remaining electrical connections according to the local codes and ordinances. If the wire connections are being made at a cabinet or wall-mounted junction box, refer to the next page. If connections are being made at the cooktop junction box, refer to the next page.



## Wiring To A Cabinet Or A Wall-Mounted Junction Box

### GROUNDING NEUTRAL

1. Connect the bare and white appliance cable wires to the white (neutral) power supply wire.
2. Carefully check each connection and make sure that it is secure, and that no bare wires can short together.
3. Twist a wire connector over the free ends of the white wires.
4. Position the wires inside the junction box, and install the cover.

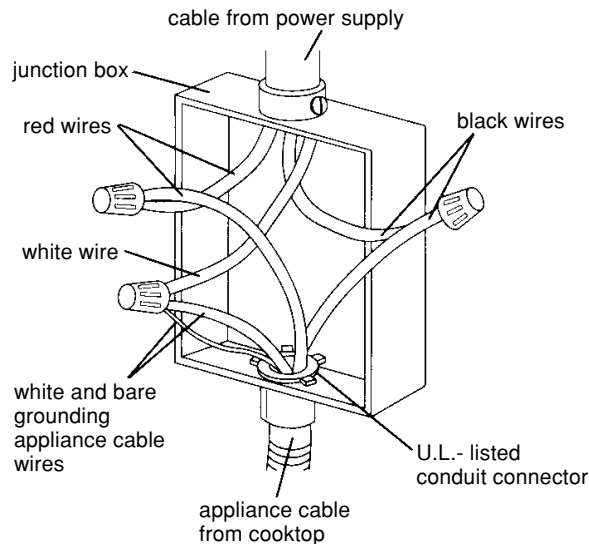

***If Local Codes Permit Connecting Cooktop Grounding Wire To White (Neutral) Wire In Junction Box***

### UNGROUNDING NEUTRAL

1. Connect the white appliance cable wire to the white (neutral) power supply wire.
2. Connect the bare grounding appliance cable wire to the green grounding power supply wire.
3. Twist wire connectors over the free ends of the white and green wires. **IMPORTANT: Do not connect the bare grounding wire to the white (neutral) wires in the junction box.**
4. Carefully check each connection and make sure that it is secure, and that no bare wires can short together.
5. Position the wires inside the junction box, and install the cover.

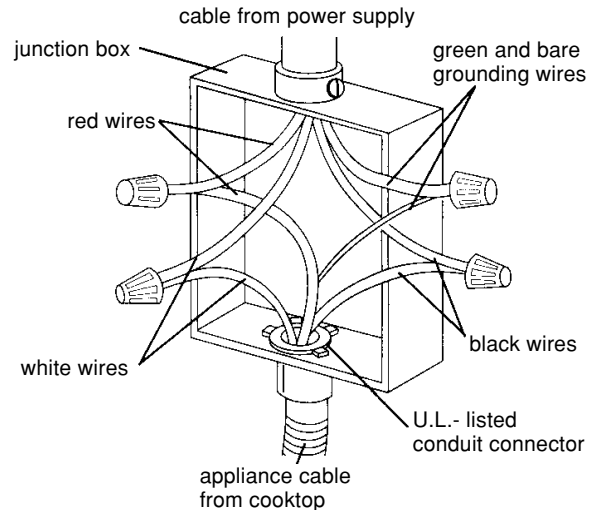

***Four-Wire Electrical System***  
***OR***  
***If Local Codes Do Not Permit Connecting Cooktop Grounding Wire To White (Neutral) Wire In Junction Box***

## Wiring To The Cooktop Junction Box

### GROUNDING NEUTRAL

1. Connect the bare and white appliance cable wires to the white (neutral) power supply wire.
2. Carefully check each connection and make sure that it is secure, and that no bare wires can short together.
3. Twist a wire connector over the free ends of the white wires.
4. Position the wires inside the junction box, and install the cover.

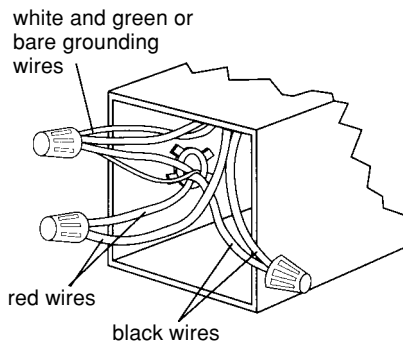

***If Local Codes Permit Connecting Cooktop Grounding Wire To White (Neutral) Wire In Junction Box***

### UNGROUNDING NEUTRAL

1. Connect the white appliance cable wire to the white (neutral) power supply wire.
2. Connect the bare grounding appliance cable wire to the green grounding power supply wire.
3. Twist wire connectors over the free ends of the white and green wires. **IMPORTANT: Do not connect the bare grounding wire to the white (neutral) wires in the junction box.**
4. Carefully check each connection and make sure that it is secure, and that no bare wires can short together.
5. Position the wires inside the junction box, and install the cover.

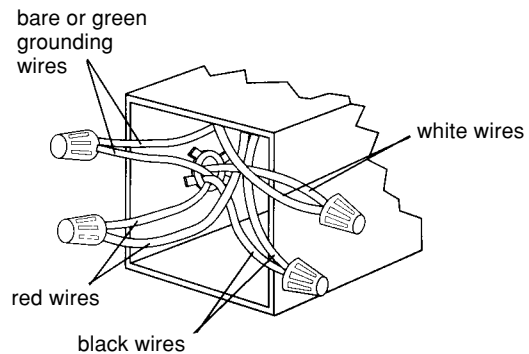

***Four-Wire Electrical System  
OR  
If Local Codes Do Not Permit Connecting  
Cooktop Grounding Wire To White (Neutral)  
Wire In Junction Box***

## VENTING OPERATION CHECK

1. Make sure that all of the control knobs on the cooktop's control panel are turned to OFF.
2. Install the cartridges, accessories, and drain jars on the cooktop (refer to the "Use and Care Guide" for the procedures).
3. Install the air filter in the cooktop vent chamber, but do not install the air grille.
4. Turn on the power supply to the cooktop junction box.
5. Locate the flow tester card that was supplied with the cooktop's printed material.
6. Place the flow tester card on top of the cooktop so that the edge of the dotted line labeled "cooktop models" is aligned with the edge of the blower intake on the left side of the cooktop near the center.
7. Turn on the fan switch. If the downdraft vent system is operating properly, the blower should pull the flow tester card into the air intake of the cooktop. If the card is not pulled into the vent, check the ductwork for obstructions.

Refer to the "Use and Care Guide" for the rest of the operating procedures.

ALIGN SIDE OF DOTTED LINE  
MARKED "COOKTOP MODELS"  
WITH AIR INTAKE

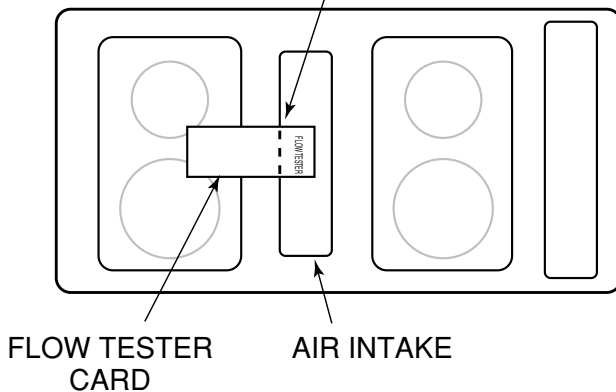

— NOTES —

# THEORY OF OPERATION

## THE COIL ELEMENTS

The coil module consists of one 6", and one 8" element. The elements are controlled by an infinite switch. When a switch is turned to the Low, Medium or High position, contacts **L1** to **H1**, and **L2** to **H2** close, and provide 240-volts to the element. At the same time, contacts **L1** to **P** close, and provide

120-volts to the surface unit indicator light. A resistor inside the switch also energizes and creates a heat load, which opens cycling contacts **L2** to **H2**. This controls the element's "on" time, and therefore its operating temperature.

The exhaust vent fan can be activated by the manual fan switch during the operation of the coil module.

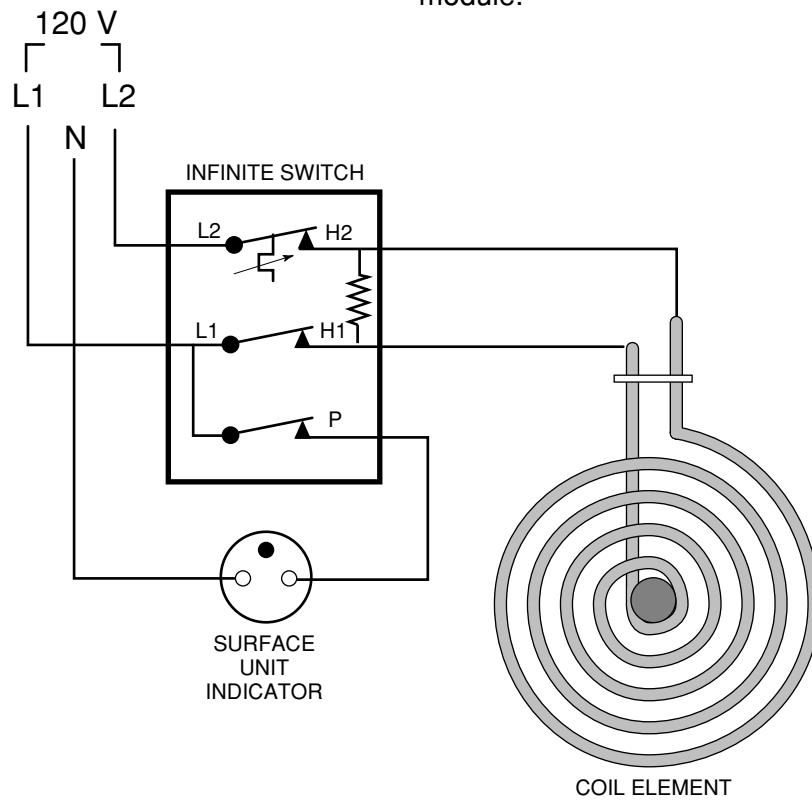

# THE RADIANT ELEMENTS

The ceramic glass module consists of one 6" and one 8" element. The elements are controlled by an infinite switch. When a switch is turned to the Low, Medium or High position, contacts **L1** to **H1**, and **L2** to **H2** close, and provide 240-volts to the element. At the same time, contacts **L1** to **P** close, and provide 120-volts to the surface unit indicator light.

A resistor inside the switch also energizes and creates a heat load, which opens cycling contacts **L2** to **H2**. This controls the element's "on" time, and therefore its operating temperature.

The exhaust vent fan can be activated by the manual fan switch during operation of the ceramic glass module.

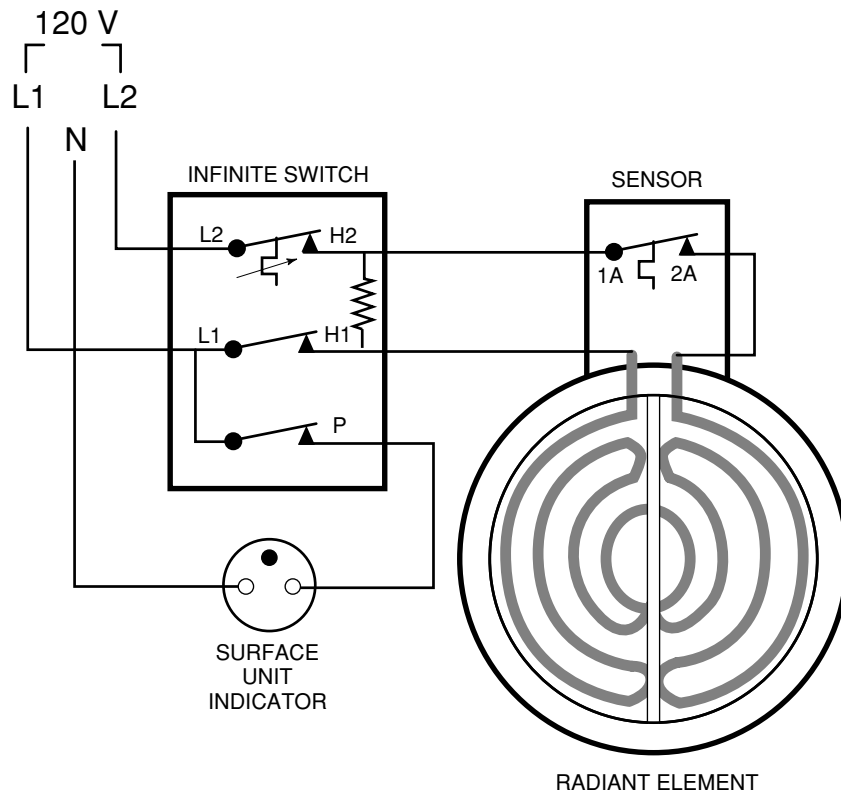

## THE GRILL ELEMENTS

A 2800-watt grill module is available for use in this cooktop. The grill consists of a front and rear element that are controlled by the infinite switches. Both a front and a rear infinite switch must be turned on to obtain full area operation of the grill. If only a front or a back switch is used, only that portion of the element will be operational.

When a switch is turned to the Low, Medium or High position, contacts **L1** to **H1**, and **L2** to **H2** close, and provide 240-volts to the element. At the same time, contacts **L1** to **P** close, and provide 120-volts to the surface unit indicator light.

Whenever one or two grill elements are energized, infinite switch contact **L1** provides 120-volts to the fan motor. The voltage is supplied to the fan motor through a metal shunt, or jumper, that is located on the plug of the grill module.

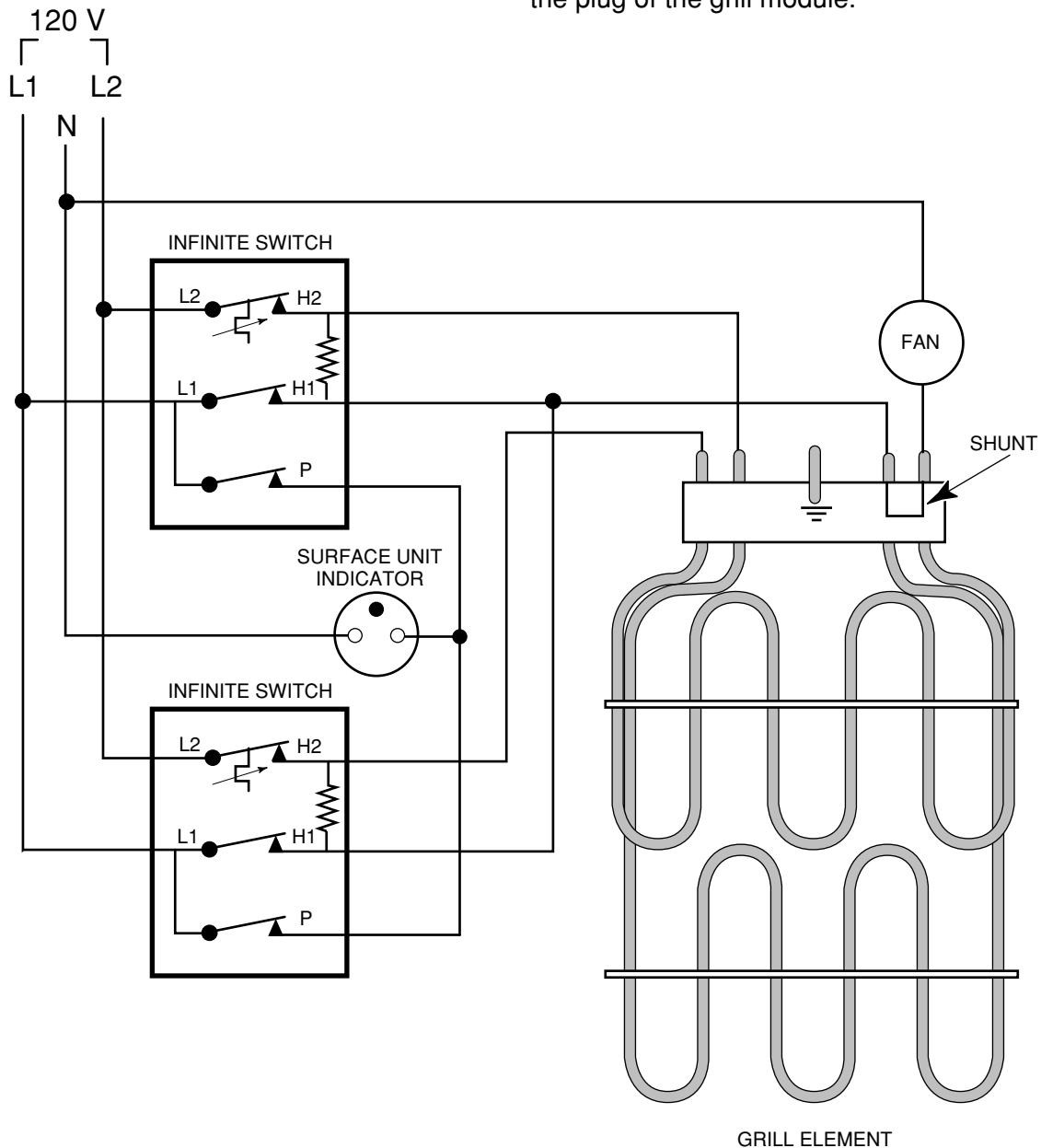

# THE FAN MOTOR

## MANUAL OPERATION

The fan motor is operated by a fan switch that is located on the control panel of the cooktop. When the switch is turned "ON," contacts **BK** to **BR** close, and provide 120-volts to the fan motor.

## AUTOMATIC OPERATION

Whenever the grill module is turned on, contact **L1** in the infinite switch provides 120-volts to the fan motor through a metal shunt, or jumper, in the plug of the grill element, and the fan motor will operate automatically.

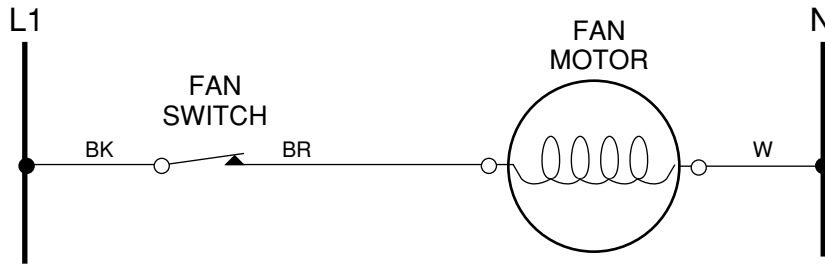



# COMPONENT ACCESS

## THE COOKTOP COMPONENTS

### Component Locations

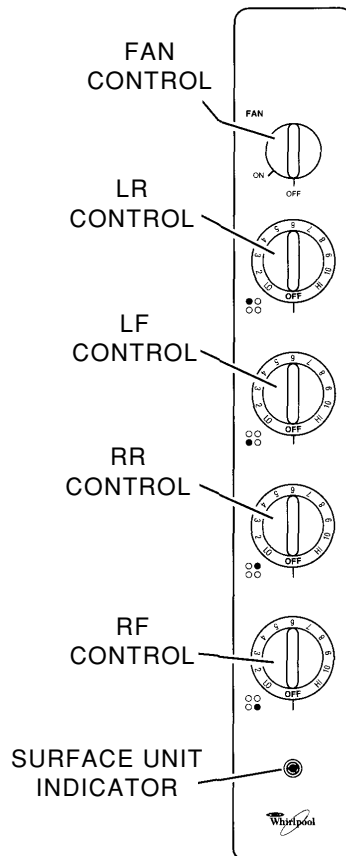
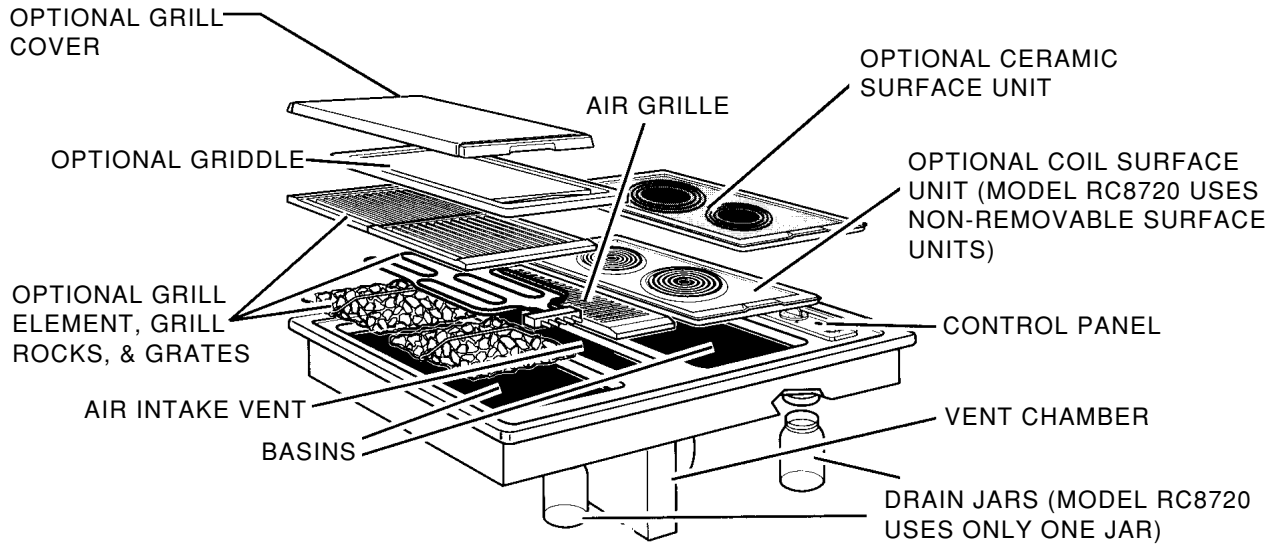

## Removing The Control Panel & The Surface Unit Indicator Light

### ! WARNING

#### Electrical Shock Hazard

Disconnect from electrical supply before servicing unit.

Failure to do so could result in electrical shock or other personal injury.

### ! CAUTION

#### Personal Injury Hazard

When you work on the cooktop, be careful when handling the sheet metal parts. Sharp edges may be present and you can cut yourself if you are not careful.

1. Remove the five control knobs from the control shafts.
2. Remove the two torx screws and the four metal inserts from the control panel.

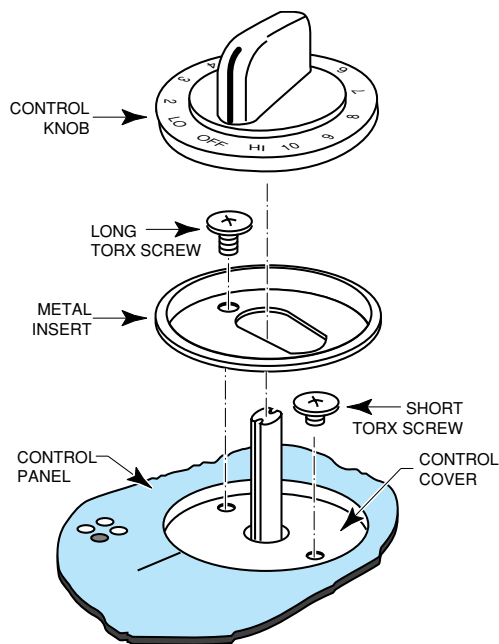

3. Remove the control panel from the cooktop. If you are replacing the panel, remove the rubber grommet from the fan shaft hole and install it in the new panel.

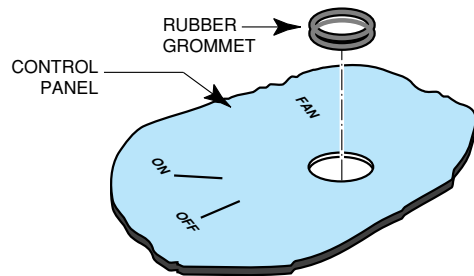

4. Remove the two torx screws from the fan control.

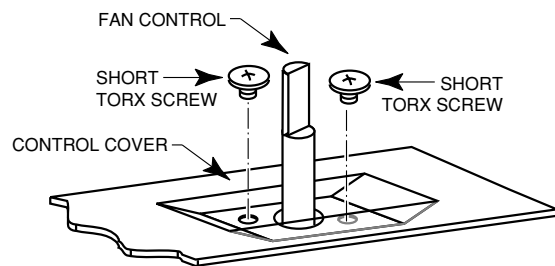

5. Remove the four hex-head screws from the control cover and lift the cover off the cooktop, then unplug the two wires from the surface unit indicator light terminals. If you are replacing the indicator light, unsnap it from the cover, and install a new one in its place.

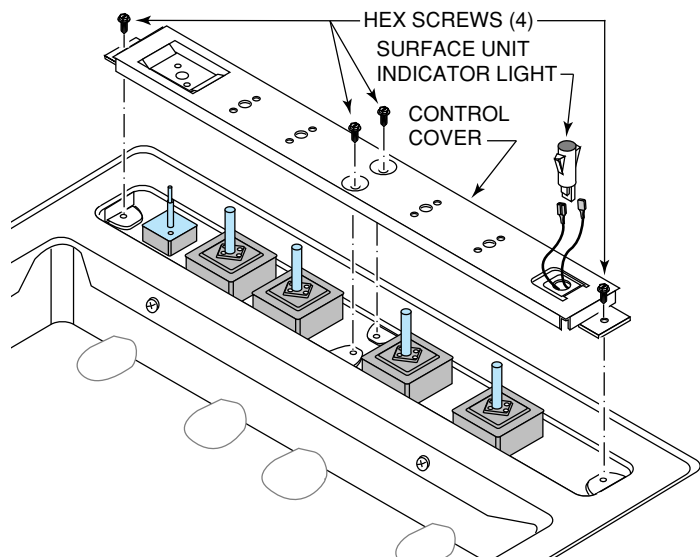

## Removing A Control Switch

### **! WARNING**

#### Electrical Shock Hazard

Disconnect from electrical supply before servicing unit.

Failure to do so could result in electrical shock or other personal injury.

### **! CAUTION**

#### Personal Injury Hazard

When you work on the cooktop, be careful when handling the sheet metal parts. Sharp edges may be present and you can cut yourself if you are not careful.

1. Remove the control cover (use the procedure shown on page 3-2).
2. Disconnect the wires from the old control switch and reconnect them to the new one.

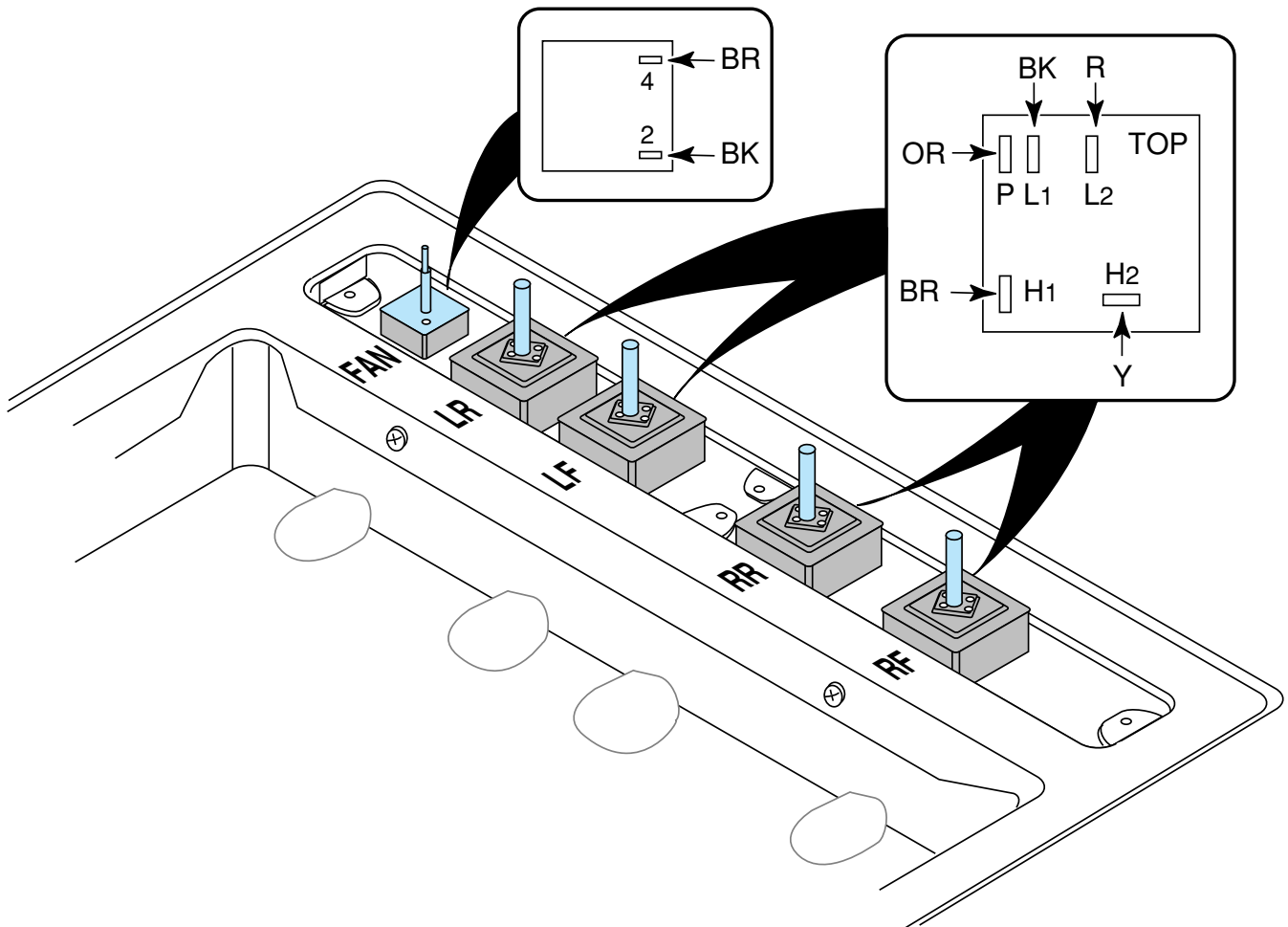

## Removing The Cooktop

### **! WARNING**

#### **Electrical Shock Hazard**

Disconnect from electrical supply before servicing unit.

Failure to do so could result in electrical shock or other personal injury.

### **! CAUTION**

#### **Personal Injury Hazard**

When you work on the cooktop, be careful when handling the sheet metal parts. Sharp edges may be present and you can cut yourself if you are not careful.

1. Turn off the electrical power to the cooktop.
2. Remove the modules, accessories, and air grille from the cooktop and set them aside.

**NOTE:** If the fan motor is supported by something other than the cooktop, remove the six screws from the top of the vent housing (see below) to release it from the cooktop. This will make it easier to remove the cooktop from the cabinet without disturbing the ductwork.

3. Raise the cooktop just enough to slide two boards, or an equivalent support, between it and the countertop. Also slide a pad under the ends of the boards to keep them from scratching the countertop.

REMOVE 6 SCREWS AT  
THIS LOCATION TO  
REMOVE VENT HOUSING  
FROM COOKTOP

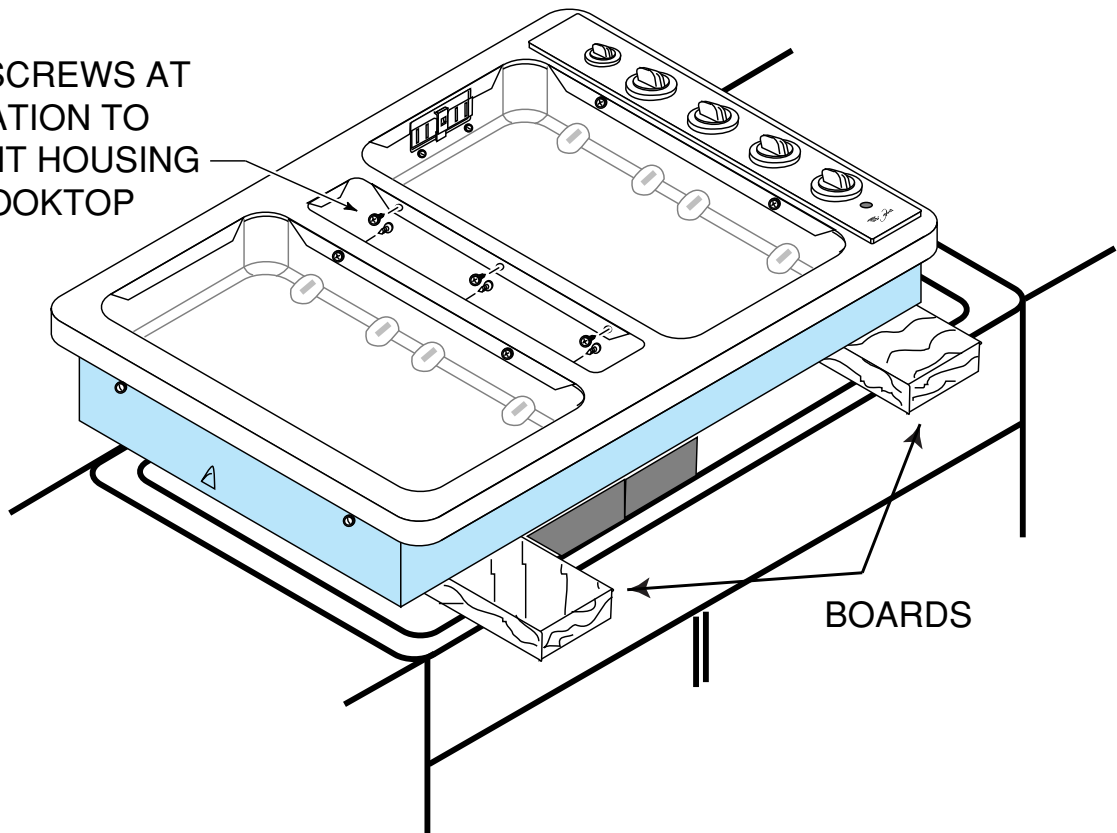

4. Remove the five control knobs from the control shafts.
5. Remove the indicated torx screw and the metal insert from each of the the controls and remove the control panel.

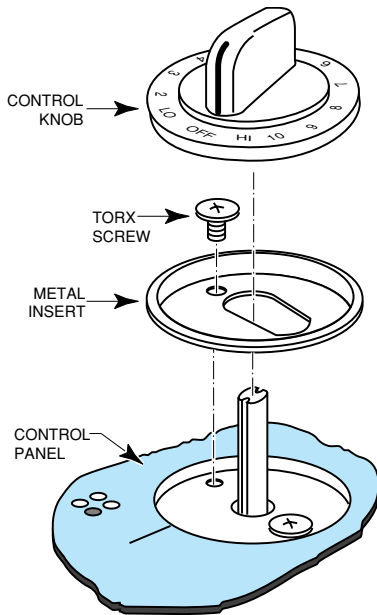

6. Remove the four hex-head screws from the control cover.

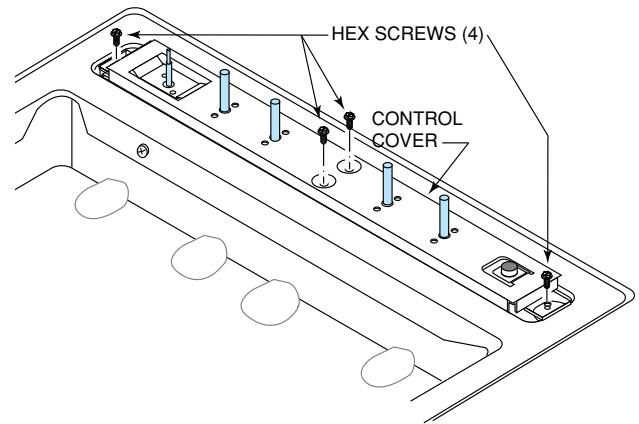

7. Remove the 10-screws shown in the illustration and lift the top off the burner box.

**REASSEMBLY NOTE:** When you install the control cover, first secure the left mounting hole of each element control to the cover with a **short** torx screw. Make sure that you align the right mounting holes after you tighten the screws so that you can install the longer torx screws later. Also use two **short** torx screws to secure the fan control to the control cover. Position the fan control with the flatted shaft facing the front.

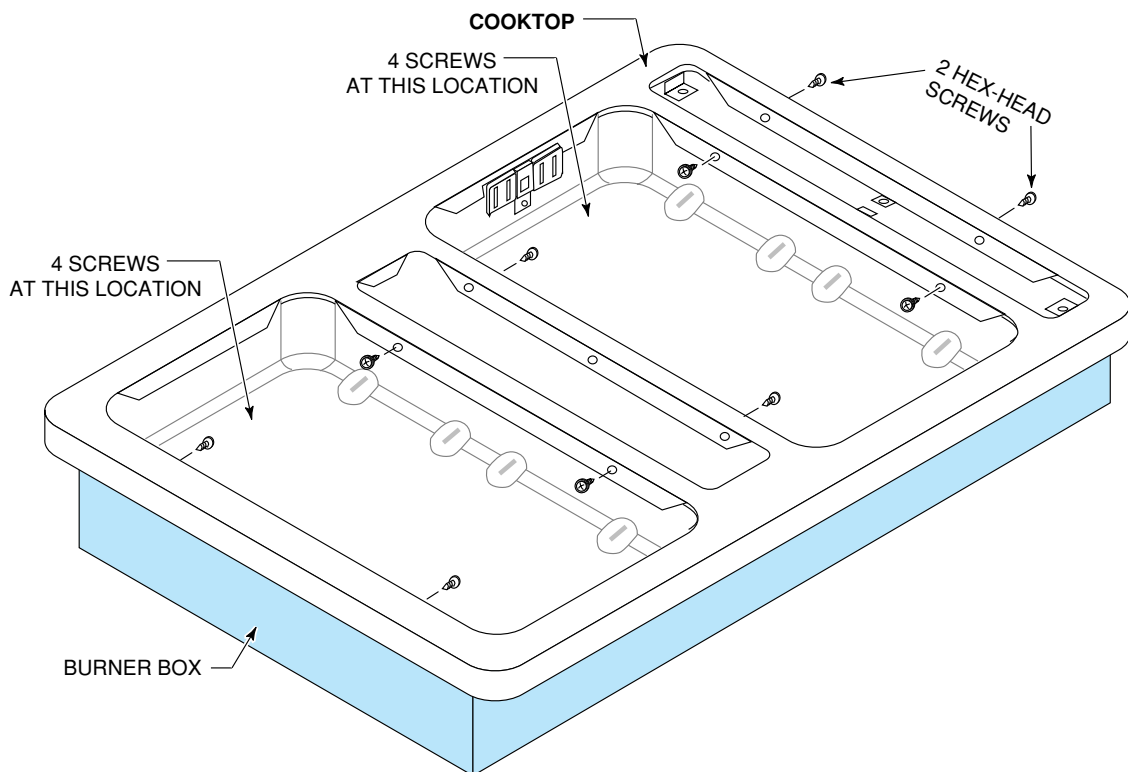

## Removing A Terminal Block

### **! WARNING**

#### **Electrical Shock Hazard**

Disconnect from electrical supply before servicing unit.

Failure to do so could result in electrical shock or other personal injury.

### **! CAUTION**

#### **Personal Injury Hazard**

When you work on the cooktop, be careful when handling the sheet metal parts. Sharp edges may be present and you can cut yourself if you are not careful.

1. Refer to page 3-4 and remove the cooktop from the countertop.
2. **To remove the rear terminal block**, remove the seven indicated hex-head screws.  
**To remove the front terminal block**, remove the two indicated torx screws and the four hex-head screws from the burner box, then remove the three hex-head screws from the front terminal block.
3. Lift the end of the cooktop just enough to remove the terminal block you are servicing.

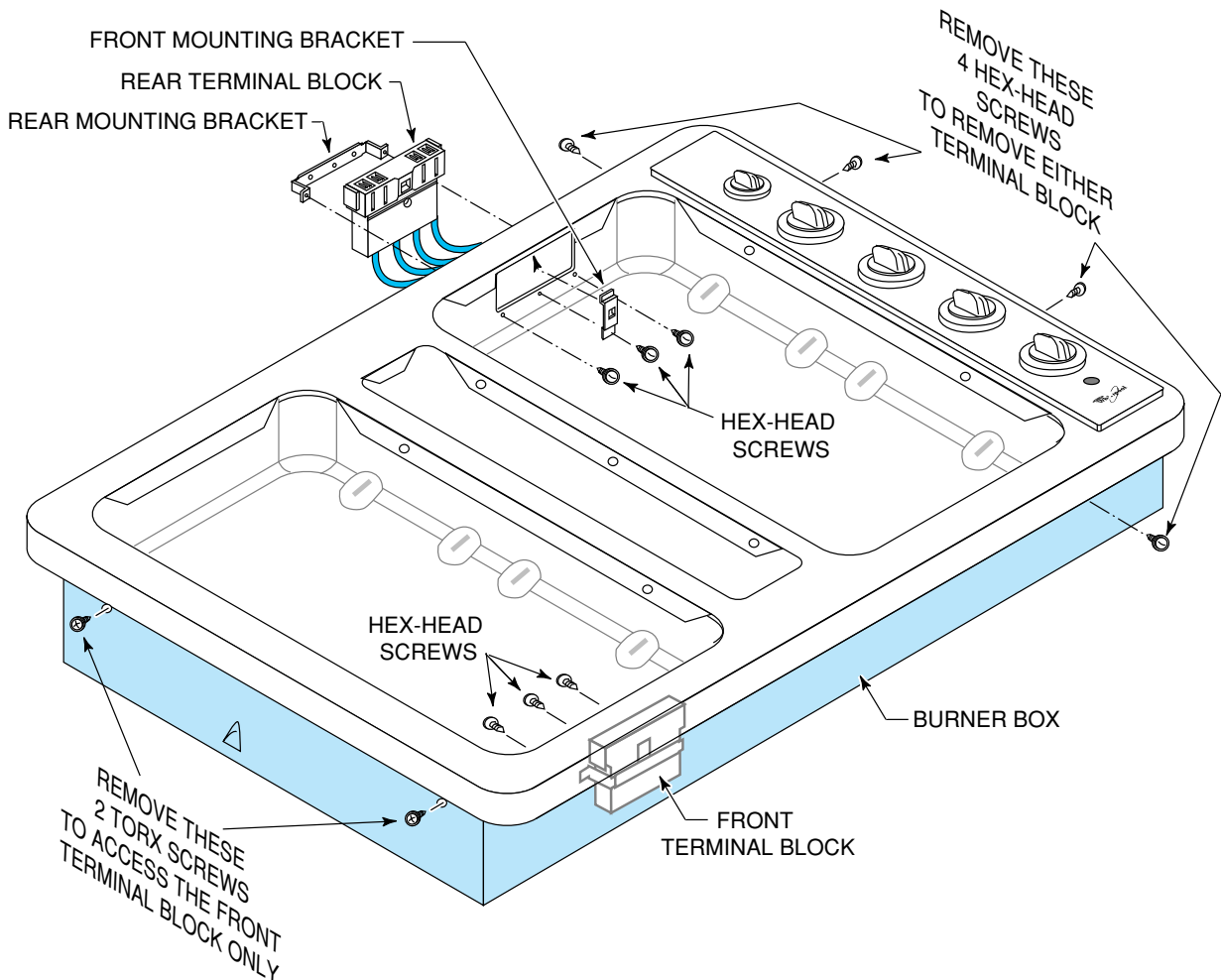

## Removing The Fan Motor

### **! WARNING**

#### Electrical Shock Hazard

Disconnect from electrical supply before servicing unit.

Failure to do so could result in electrical shock or other personal injury.

### **! CAUTION**

#### Personal Injury Hazard

When you work on the cooktop, be careful when handling the sheet metal parts. Sharp edges may be present and you can cut yourself if you are not careful.

1. Turn off the electrical power to the cooktop.
2. Remove the four hex-head nuts from the fan motor.
3. Unplug the quick-disconnects from the fan motor and remove the motor from the vent housing.
4. Loosen the setscrew on the fan drum hub and slide the fan drum off the shaft of the old motor.
5. Remove the three cover mounting screws and remove the old motor and strain relief from the motor cover, then reinstall the new motor and strain relief into the cover, and secure the motor with its three screws.

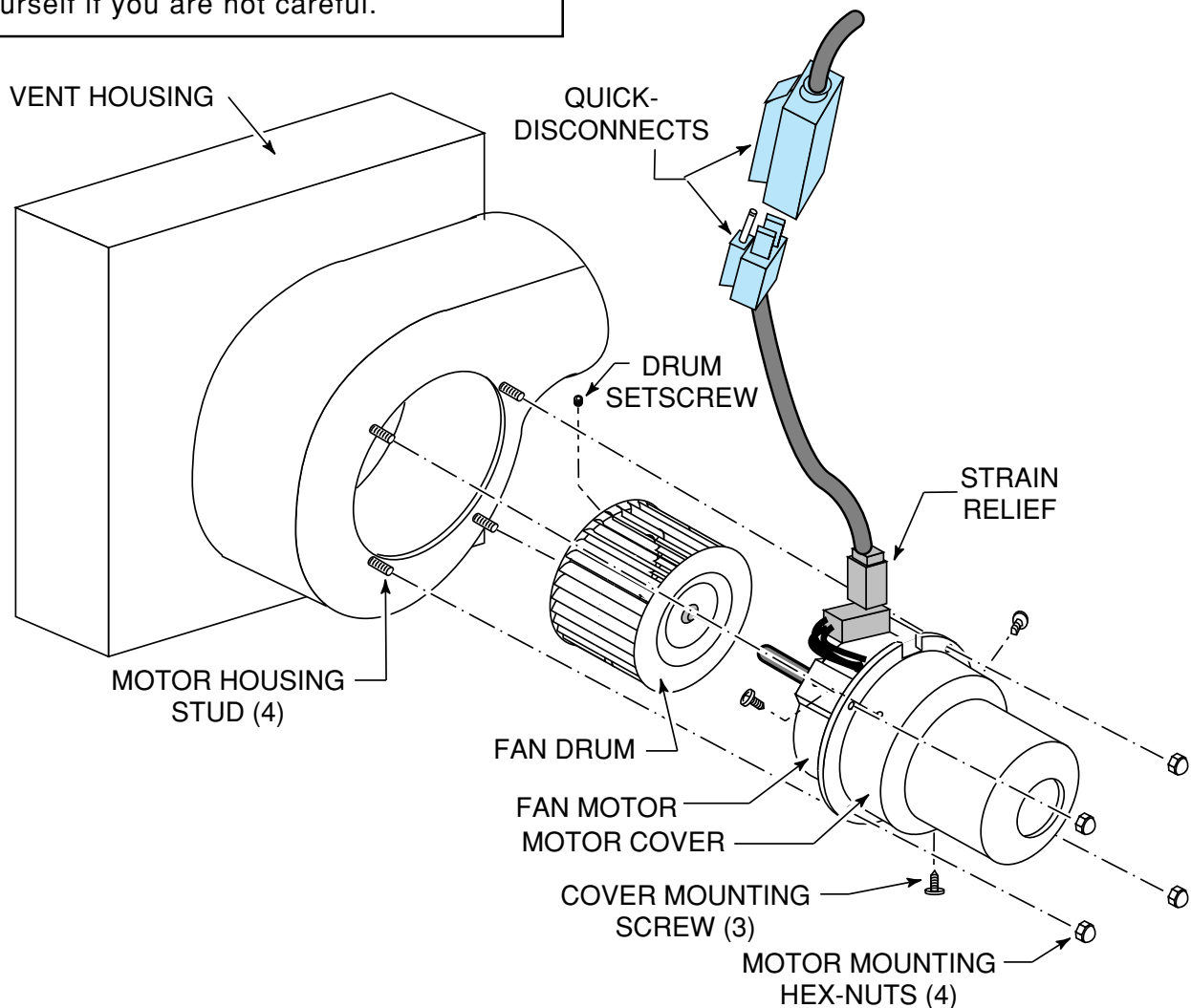

# MODULE COMPONENTS

## The Ceramic Surface Unit RCM30DB/Q

### Removing The Glass, Element, Or Limiter

## ! WARNING

### Electrical Shock Hazard

Disconnect from electrical supply before servicing unit.

Failure to do so could result in electrical shock or other personal injury.

## ! CAUTION

### Personal Injury Hazard

When you work on the cooktop, be careful when handling the sheet metal parts. Sharp edges may be present and you can cut yourself if you are not careful.

1. Turn off the electrical power to the cooktop.
2. Make sure that the ceran glass is cool, then unplug the ceramic surface unit from the cooktop, and position it on a padded work surface.

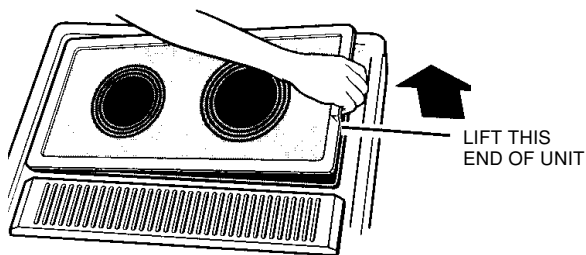

3. Remove the seven hex-head screws from around the ceran glass frame and lift it off the base.
4. If you are replacing the ceran glass, remove the eight clips and push the old glass out of the frame, then install the new glass and clips. Make sure that you install the new glass with the large element outline toward the raised opening in the frame.

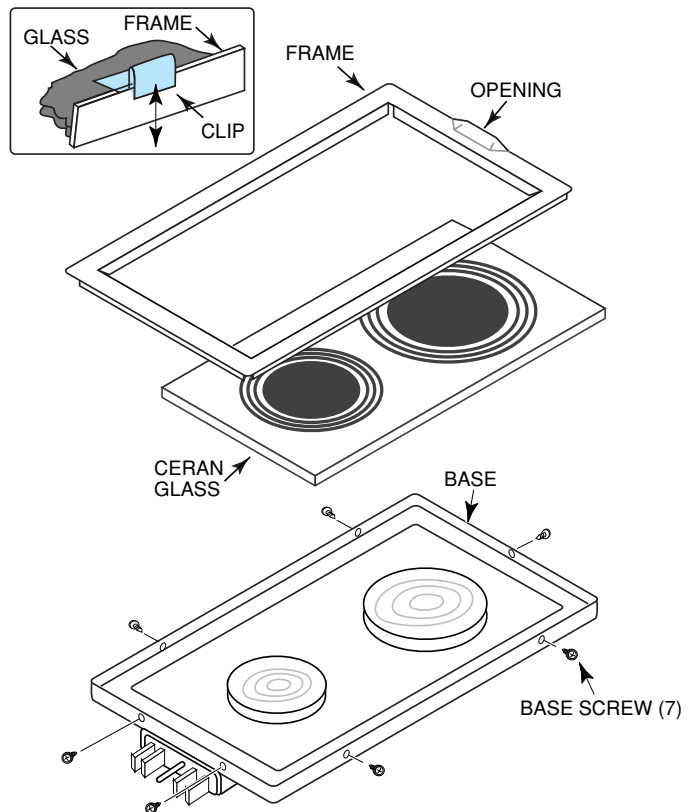



NOTE: If you are replacing an element, perform steps 5 and 6. If you are replacing just a limiter, proceed to step 7.

5. With the wires connected to the terminals, lift the old element out of the base, and install the new one in its place with the terminals positioned the same as the old one.
6. One at a time, disconnect the wires from the terminals of the old element, and reconnect them to the same terminal locations on the new one.
7. Lift the element with the defective limiter so you can access the bottom, and remove the screws from the old limiter, then pull the sensing tube out of the element, and remove the limiter.

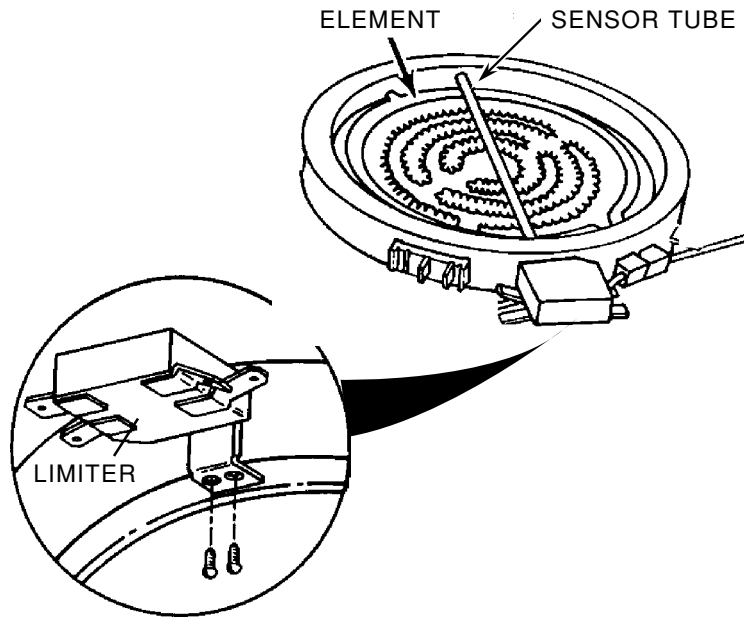

# The Coil Surface Unit RCM10DB/Q

## Removing A Coil Element & Connector

### **! WARNING**

#### **Electrical Shock Hazard**

Disconnect from electrical supply before servicing unit.

Failure to do so could result in electrical shock or other personal injury.

### **! CAUTION**

#### **Personal Injury Hazard**

When you work on the cooktop, be careful when handling the sheet metal parts. Sharp edges may be present and you can cut yourself if you are not careful.

1. Turn off the electrical power to the cooktop.
2. Make sure that the coil element you are removing is cool.
3. To remove a coil element, lift the front of the coil element, unplug it from the connector, and remove it.

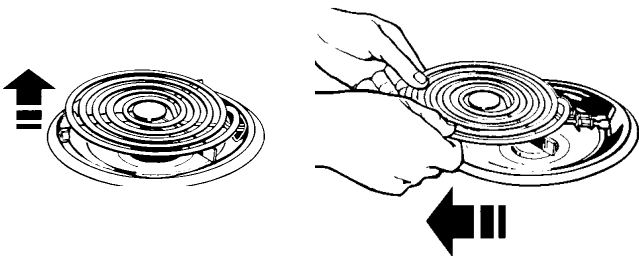

4. To replace the coil element connector, remove the coil module from the cooktop.

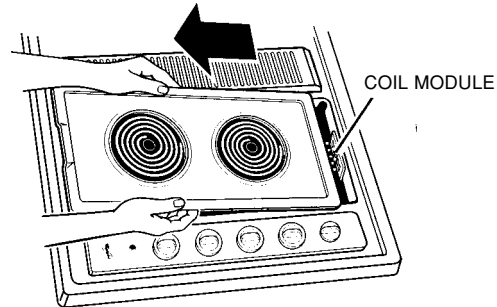

5. Remove both coil elements, (see step 3), as well as the reflector bowls from the module.

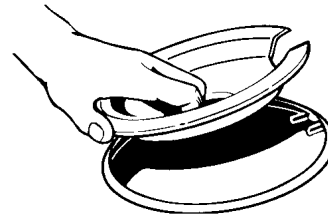

6. Remove the seven hex-head screws from around the coil module top and lift it off the base.
7. Remove the terminal block mounting bracket screw from the bottom of the base.
8. Slide the mounting bracket and the insulator away from the terminal block so that you can access the prong wire screw.
9. Remove the prong wires from the prong for the defective coil element connector and install the wires from the new connector in their place.

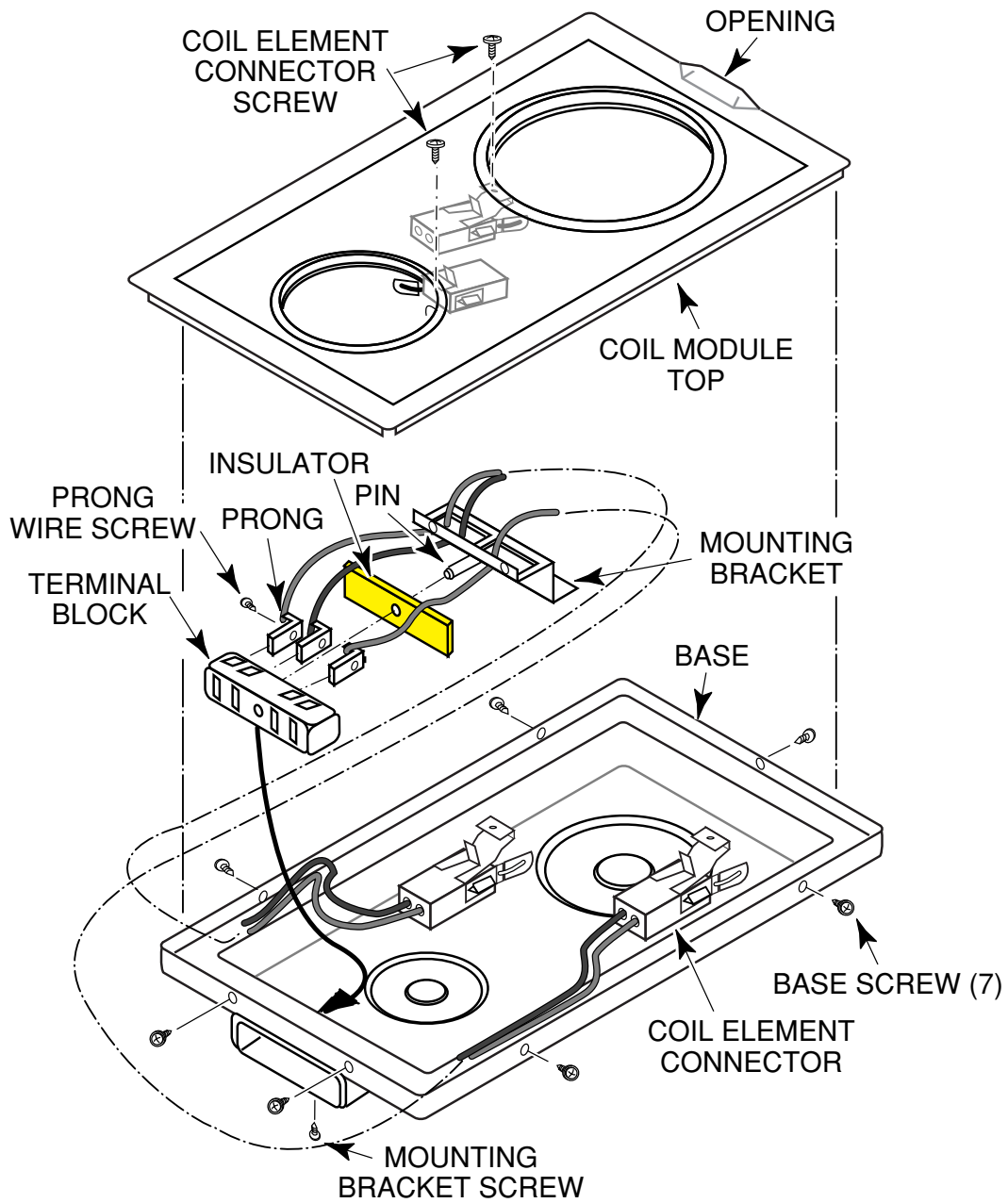

## The Grill RCM20DB Removing The Grill Element

### **! WARNING**

#### **Electrical Shock Hazard**

Disconnect from electrical supply before servicing unit.

Failure to do so could result in electrical shock or other personal injury.

### **! CAUTION**

#### **Personal Injury Hazard**

When you work on the cooktop, be careful when handling the sheet metal parts. Sharp edges may be present and you can cut yourself if you are not careful.

1. Turn off the electrical power to the cooktop.
2. Make sure that the grill element is cool.
3. To remove the grill element, remove the grill grates from the cooktop.

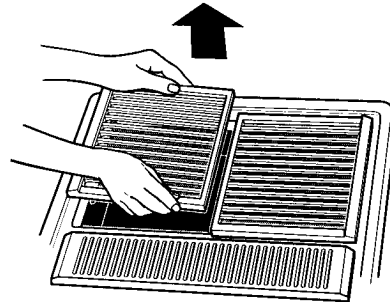

4. Unplug the grill element and remove it.

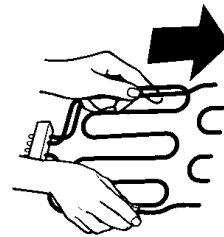

## Removing A Terminal Plug Connector

### ⚠ WARNING

#### Electrical Shock Hazard

Disconnect from electrical supply before servicing unit.

Failure to do so could result in electrical shock or other personal injury.

### ⚠ CAUTION

#### Personal Injury Hazard

When you work on the cooktop, be careful when handling the sheet metal parts. Sharp edges may be present and you can cut yourself if you are not careful.

1. Turn off the electrical power to the cooktop.
2. Make sure that the module you are servicing is cool and remove it from the cooktop.
3. Remove the seven hex-head screws from around the module top and lift it off the base.
4. Remove the terminal block mounting bracket screw from the bottom of the base.
5. Slide the mounting bracket and the insulator away from the terminal block.
6. Replace the defective part.
7. Reassemble the terminal plug connector so that the pin and prongs fit into their terminal block openings and mount the bracket to the base with its screw. **NOTE: Make sure to reinstall the shunt between the indicated prongs if you are servicing a grill element, otherwise the fan motor will not operate.**

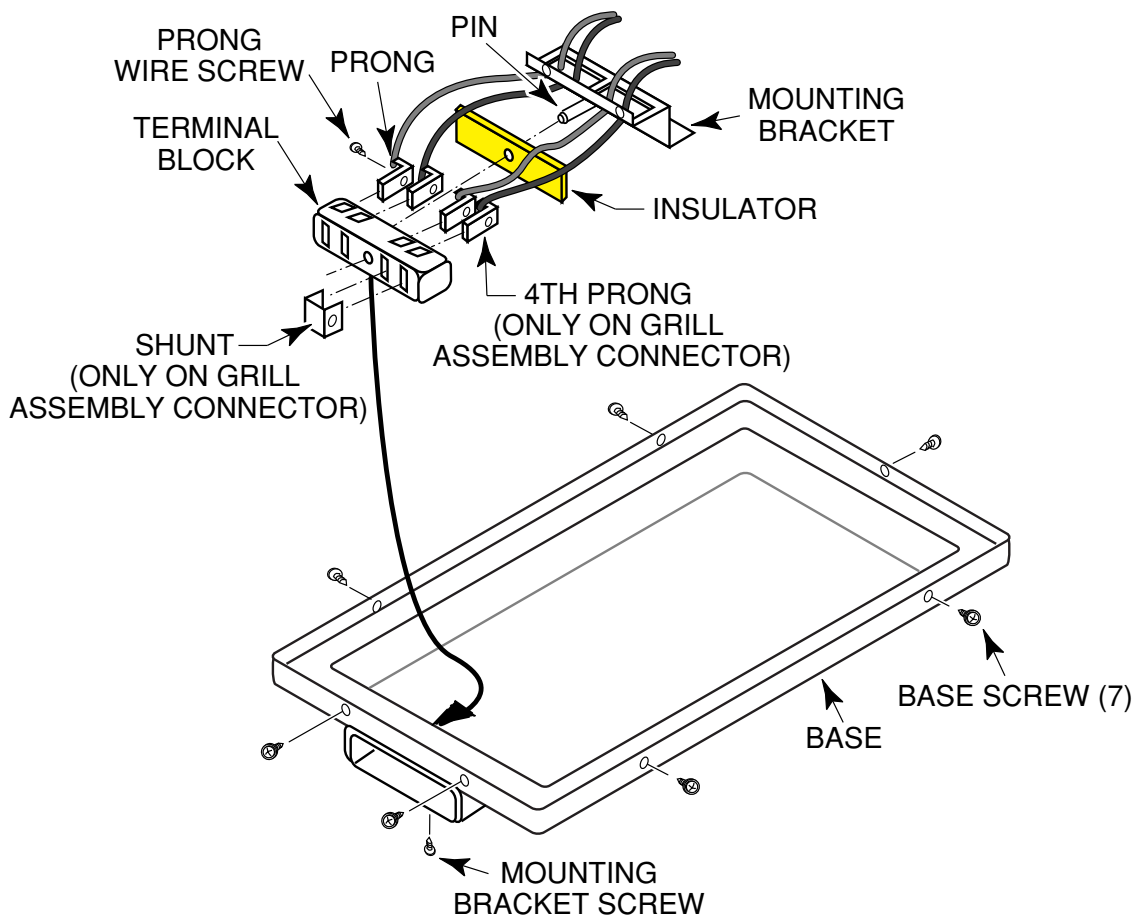

— NOTES —

# COMPONENT TESTING

## TROUBLESHOOTING

### ⚠ WARNING

#### Electrical Shock Hazard

Certain procedures in this section require electrical tests or measurements while power is applied to the cooktop. Exercise extreme

caution at all times. If test points are not easily accessible, disconnect power, attach test equipment, and reapply power to test.

### CONTROL SWITCH

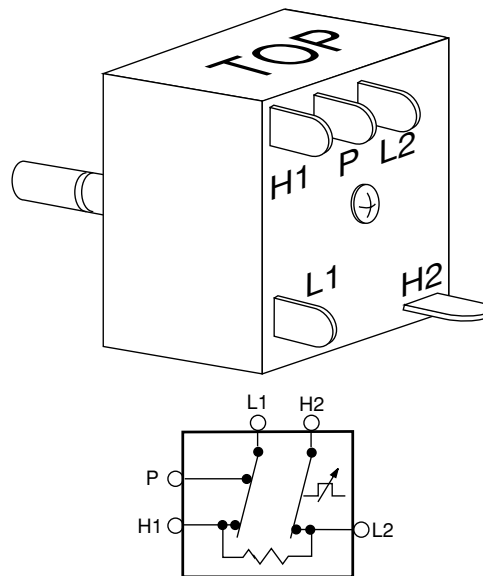

### ⚠ WARNING

#### Electrical Shock Hazard

Disconnect from electrical supply before servicing unit.

Failure to do so could result in electrical shock or other personal injury.

### Test Procedure

Refer to page 3-3 for the procedure for servicing a control switch.

To test a switch, perform the following steps:

1. Use an ohmmeter and set the range switch to R x 1.
2. With no power applied and the switch turned ON, you should obtain continuity between the terminals, as indicated.

<i>Switches (ON)</i>	<i>Continuity Between Terminals:</i>		
	L1-H1	L1-P	H2-L2

## LIMITER

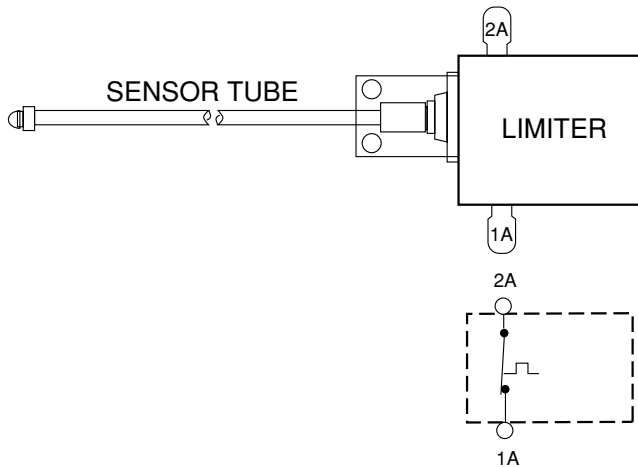

### **! WARNING**

#### Electrical Shock Hazard

Disconnect from electrical supply before servicing unit.

Failure to do so could result in electrical shock or other personal injury.

### Test Procedure

Refer to page 3-8 for the procedure for servicing a limiter.

To test a limiter, perform the following steps:

1. Use an ohmmeter and set the range to R x 1.
2. With no power applied, touch the ohmmeter leads to the following terminals. You should obtain the following readings at the indicated temperature:

1A and 2A opens @ 1025°F.

If the readings are not within the range shown, the limiter is defective and should be replaced.

## RADIANT ELEMENTS

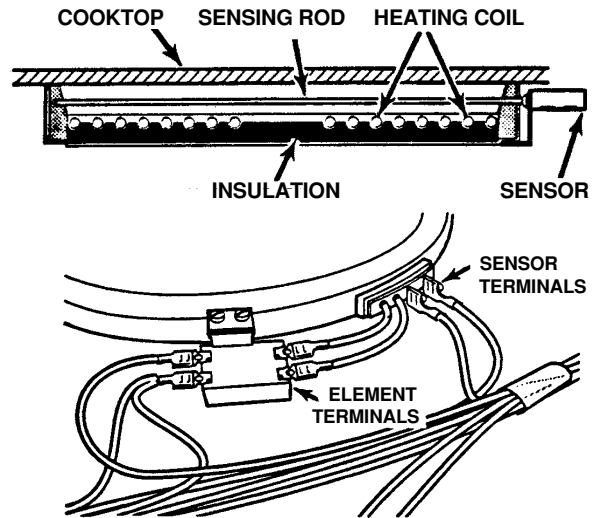

### **! WARNING**

#### Electrical Shock Hazard

Disconnect from electrical supply before servicing unit.

Failure to do so could result in electrical shock or other personal injury.

### Test Procedure

Refer to page 3-8 for the location of the elements and the procedure for servicing them.

To test an element, perform the following steps:

1. Use an ohmmeter and set the range switch to R x 1.
2. With no power applied, disconnect one wire from the element terminals.
3. You should obtain the reading for the indicated element:

RADIANT (CERAN)		
Dia.	Watts	Ohms
6"	1200	46 ±5
8"	1800	33 ±5

ALL WATTAGES ARE AT 240 VOLTS, A.C.



## COIL ELEMENTS

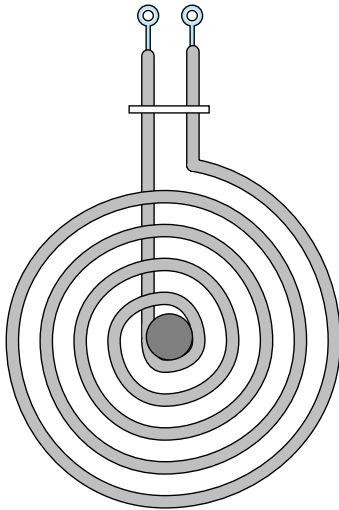

### **! WARNING**

#### Electrical Shock Hazard

Disconnect from electrical supply before servicing unit.

Failure to do so could result in electrical shock or other personal injury.

### Test Procedure

Refer to page 3-10 for the location of the elements and the procedure for servicing them.

To test an element, perform the following steps:

1. Use an ohmmeter and set the range switch to R x 1.
2. With no power applied, disconnect one wire from the element terminals.
3. You should obtain the reading for the indicated element:

COIL ELEMENT		
Dia.	Watts	Ohms
6"	1250	46 ±5
8"	2100	27 ±5

ALL WATTAGES ARE AT 240 VOLTS, A.C.

## GRILL ELEMENTS

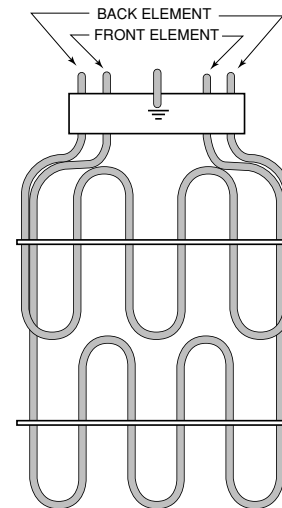

### **! WARNING**

#### Electrical Shock Hazard

Disconnect from electrical supply before servicing unit.

Failure to do so could result in electrical shock or other personal injury.

### Test Procedure

Refer to page 3-12 for the location of the elements and the procedure for servicing them.

To test an element, perform the following steps:

1. Use an ohmmeter and set the range switch to R x 1.
2. With no power applied, disconnect one wire from the element terminals.
3. You should obtain the reading for the indicated element:

GRILL ELEMENT		
Loc.	Watts	Ohms
Front	1400	40 ±5
Back	1400	40 ±5

ALL WATTAGES ARE AT 240 VOLTS, A.C.

## Troubleshooting Chart

PROBLEM	POSSIBLE CAUSE	SOLUTION
Element does not heat.	No line voltage. Loose or bad wiring. Defective element.	Repair or replace wiring (see wiring diagrams). Test and/or replace element.
Element barely heats.	Low line voltage.  Loose or bad wiring connection at element or terminal block. Defective cooktop control switch.	Line voltage should be minimum 240-volts. If necessary, electrician should repair cause for low line voltage. Repair or replace wiring (see wiring diagrams). Test and/or replace switch.
Element will not heat higher than low-medium.	Low line voltage.  Defective cooktop element.	Line voltage should be minimum 240-volts. Electrician should repair cause for low line voltage. Test and/or replace element.
Element heats up normally, but drops to lower setting automatically.	Customer using improper cookware. Defective cooktop control switch.	Evaluate suitability of cookware. Test and/or replace switch.
On indicator light does not work.	Loose or defective light. Loose or bad wiring to indicator light assembly.	Replace indicator light. Replace indicator light assembly and wiring.

# TECH TIPS

## SCHEMATIC DIAGRAM Model RC8700ED

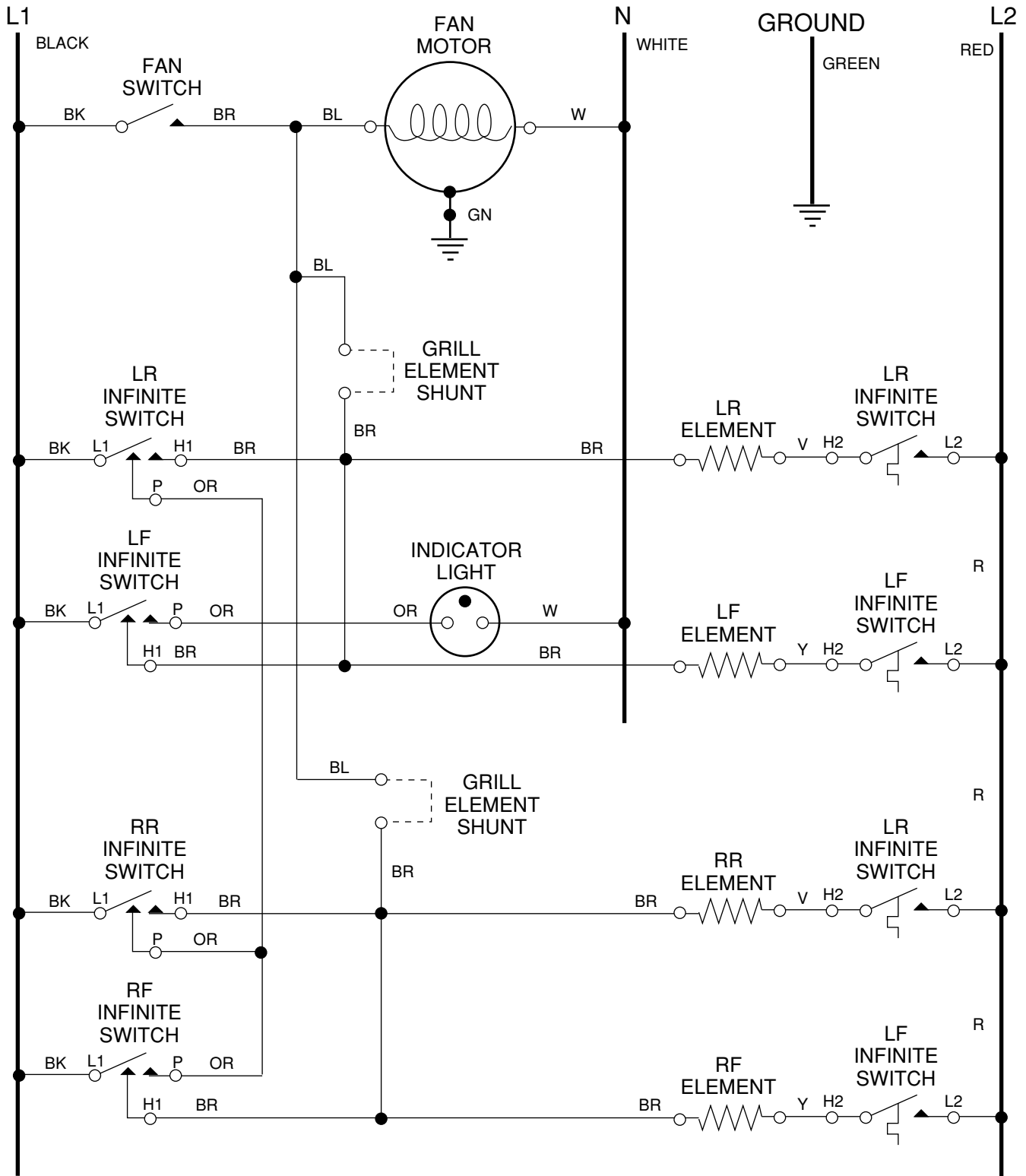

# WIRING DIAGRAM

## Model RC8700ED

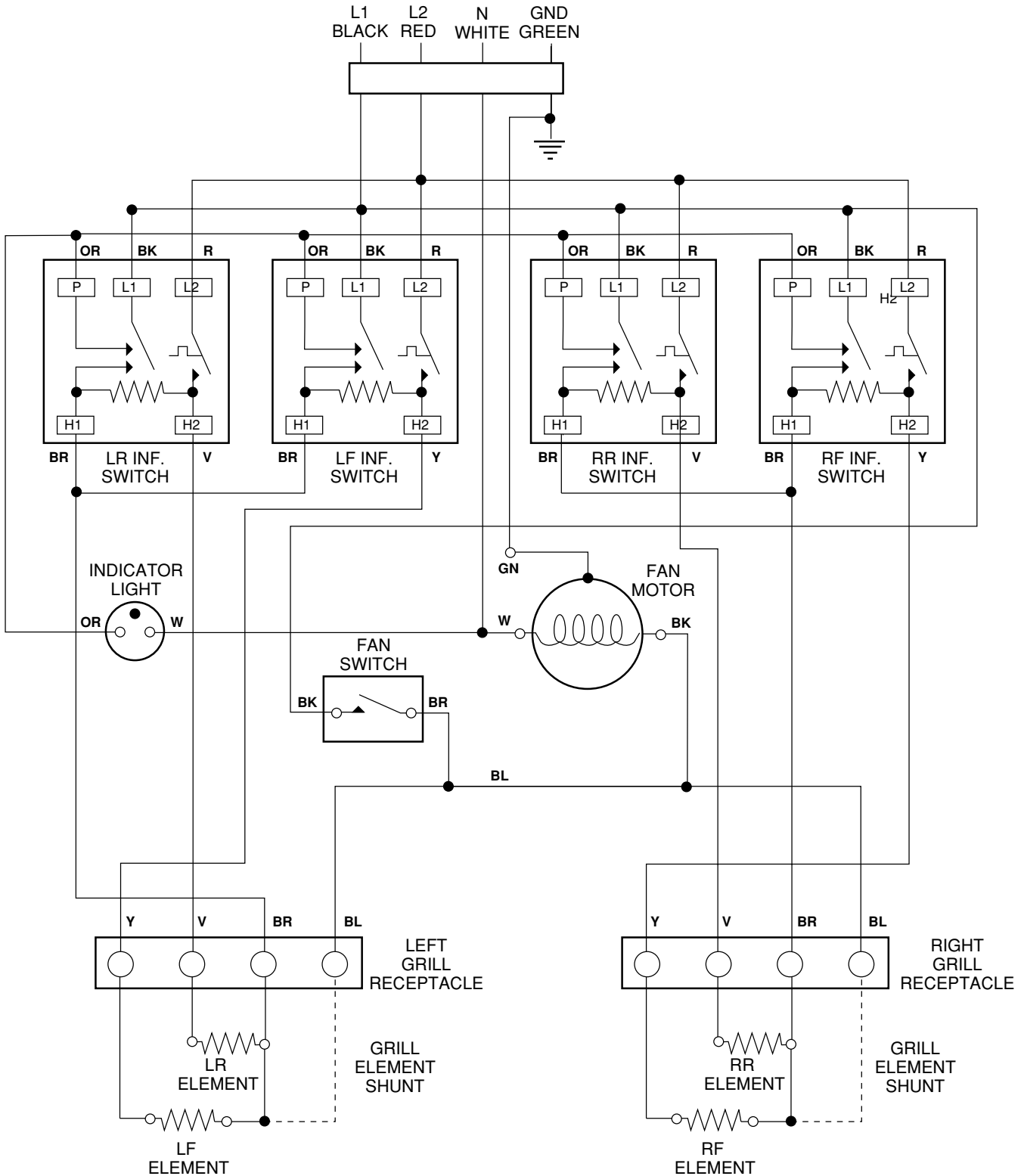

# SCHEMATIC DIAGRAM

## Model RC8720ED

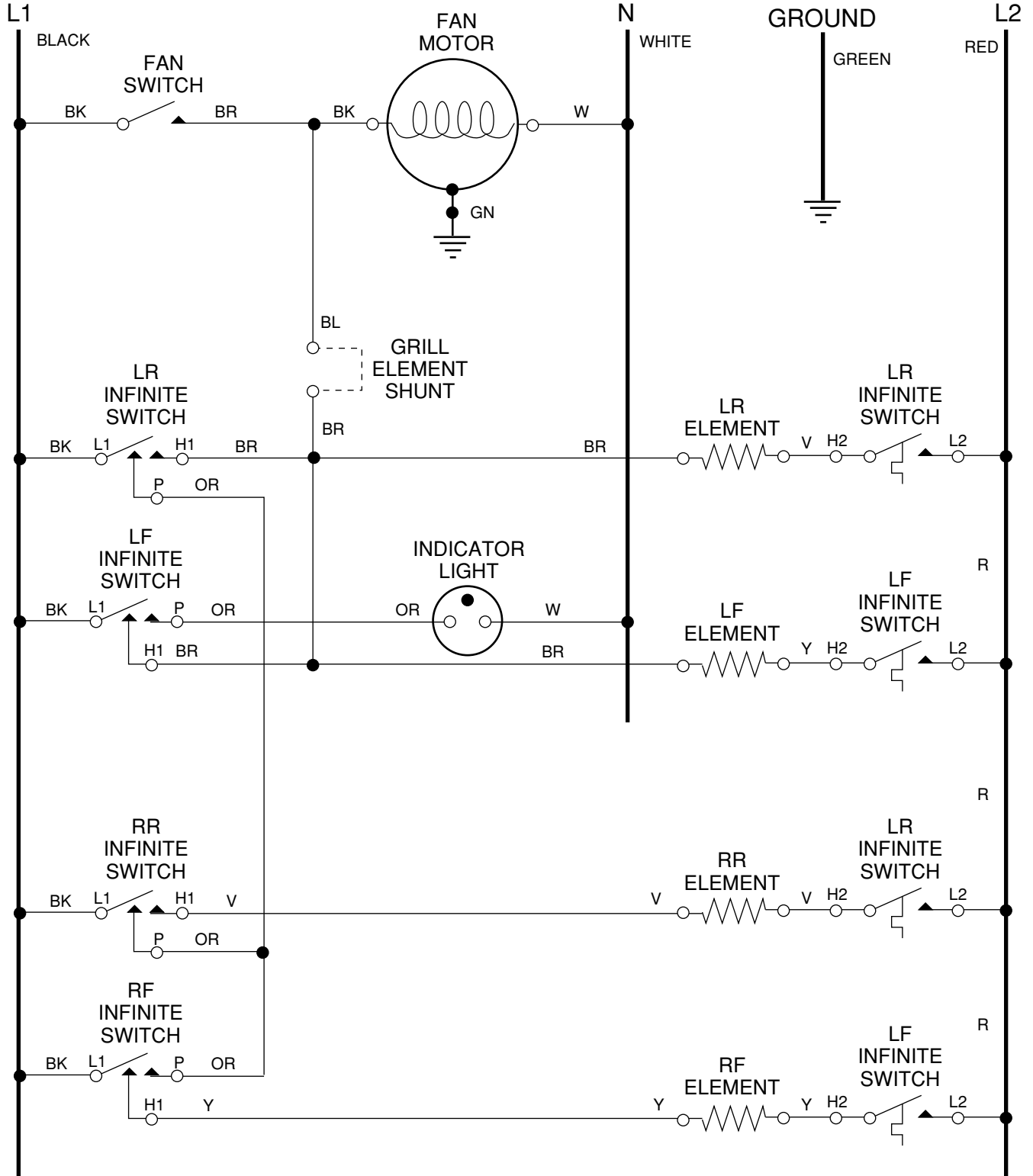

# WIRING DIAGRAM

## Model RC8720ED

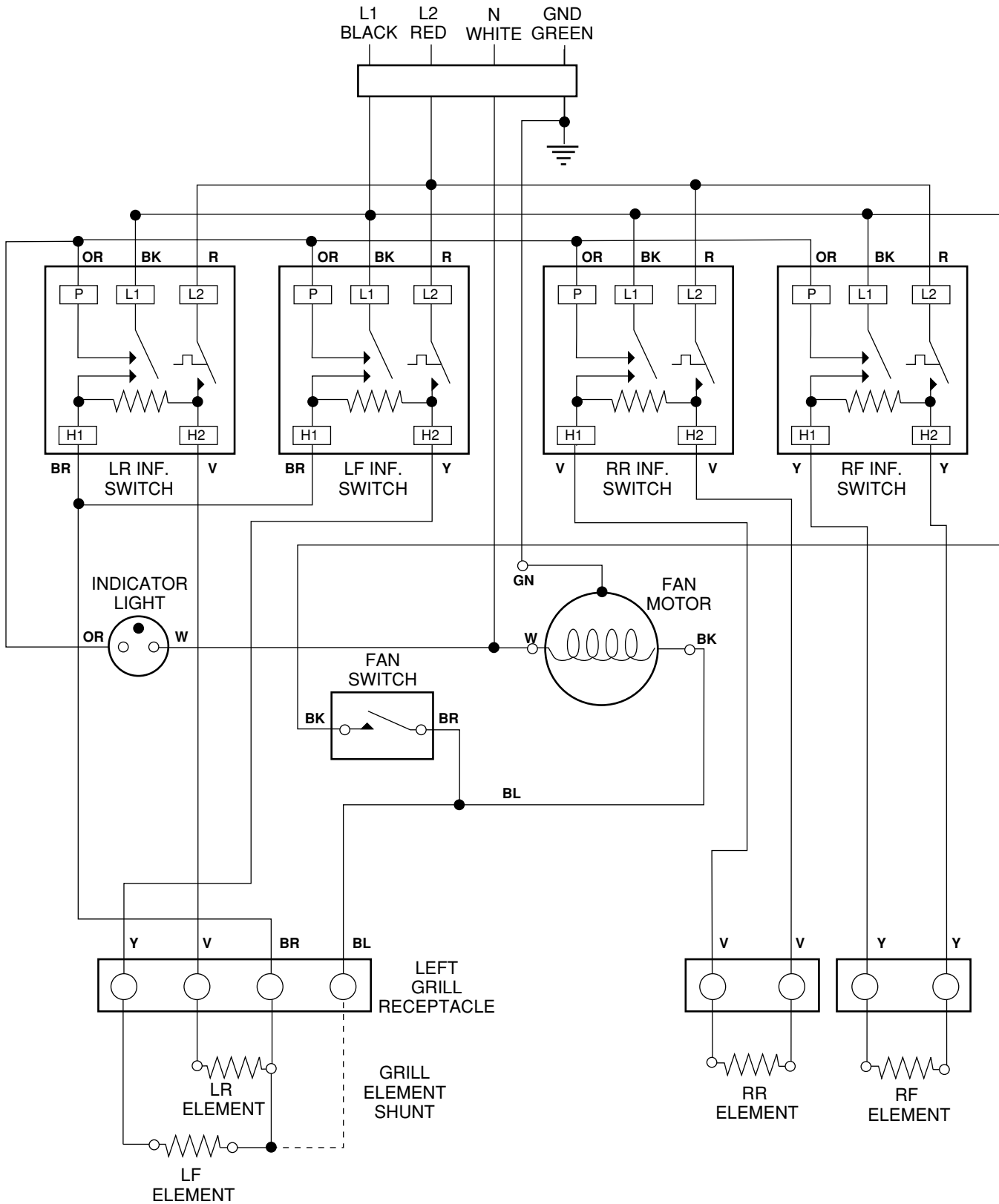

# STRIP CIRCUITS

## RADIANT ELEMENT

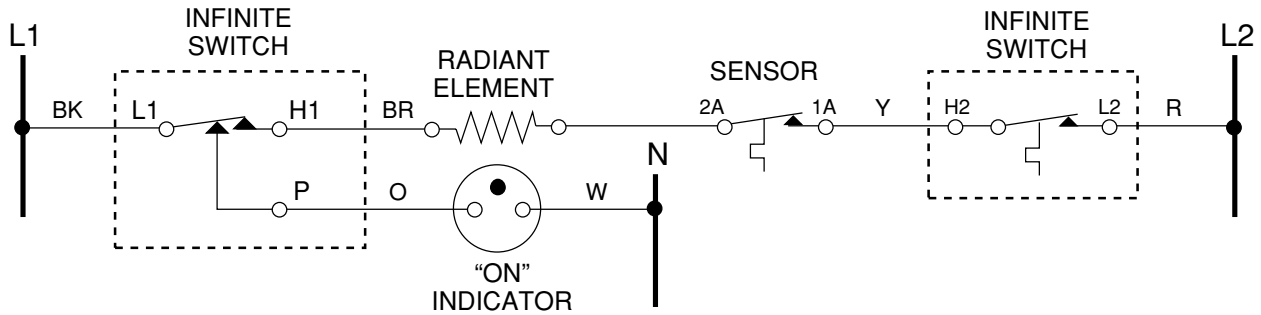

## COIL ELEMENT

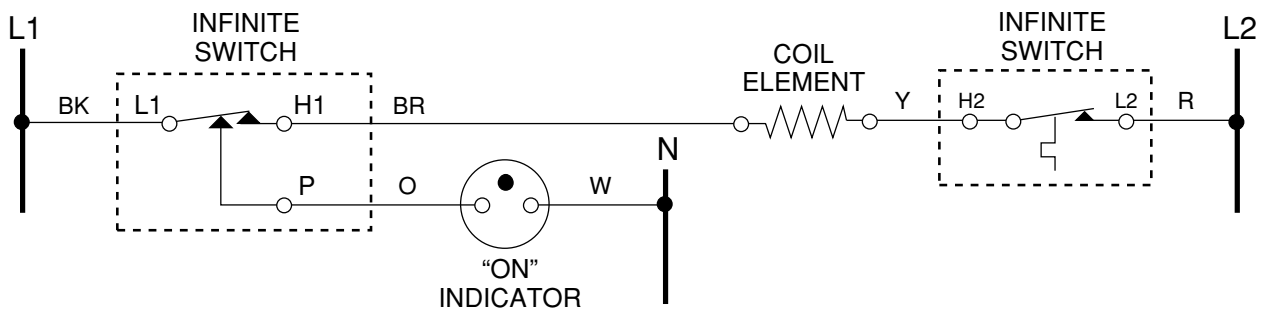

## GRILL ELEMENT

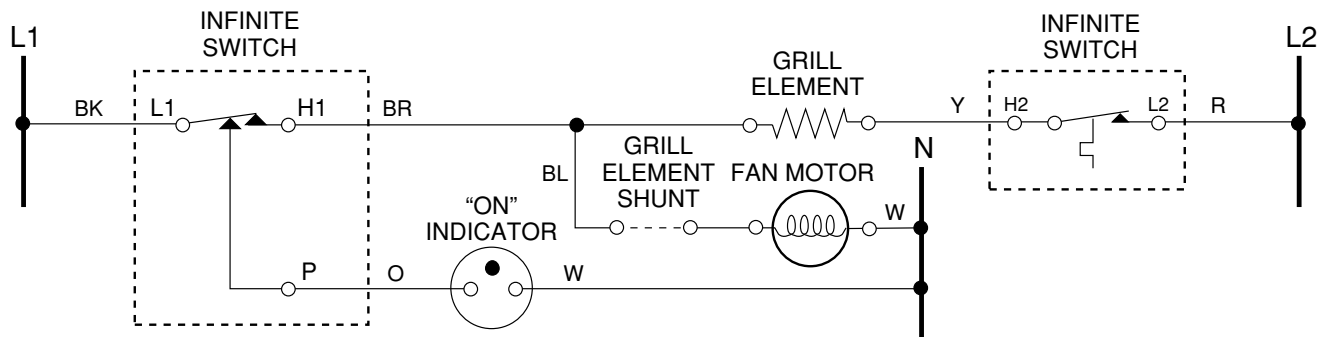

# SPECIFICATIONS

## Model RC8700EDB/W

<b>MODEL NUMBER</b>	<b>RC8700EDB</b>	<b>RC8700EDW</b>
<i>Cooktop Colors:</i>		
Perimeter Finish	Porcelain Black	Porcelain White
Control Panel	Black	White
Control Panel Graphics	White	Ascot Grey
Control Panel Accents	Persimmon Red	Persimmon Red
<i>Dimensions (Inches):</i>		
Overall Width	29-7/8	29-7/8
Overall Depth	21-1/2	21-1/2
Cutout Width	28-7/8	28-7/8
Cutout Depth	20-7/8	20-7/8
Blower Assembly Clearance (Below Countertop)	16-7/16	16-7/16
<i>Cooktop Features:</i>		
Right Bay	Open	Open
Left Bay	Open	Open
Number of Bays Convertible	Double Convertible	Double Convertible
Control Location	Right Side	Right Side
Indicator Light	On/Off	On/Off
Control Type	Standard Mechanical	Standard Mechanical
Blower	300 CFM	300 CFM
Blower Switch	On/Off Dial	On/Off Dial
<i>Other Specifications:</i>		
Total Connected Load	7.7 kW	7.7 kW
Electrical Requirements	32.1 Amp Circuit	32.1 Amp Circuit
Junction Box w/o Power Cord	Yes	Yes
Warranty	1-Year Full — 2-Year Parts	1-Year Full — 2-Year Parts
Approximate Weight	51 Lbs.	51 Lbs.
Agency Approval	U.L. - C.S.A.	U.L. - C.S.A.





MODEL NUMBER	RC8700EDB	RC8700EDW
<i>Approved Modules:</i>		
2-Elements Fixed Coil Module	RCM10DB	RCM10DQ
2-Elements Radiant Ceran	RCM30DB	RCM10DQ
Grill (Left Bay Only)	RCM20DB	RCM20DB
<i>Approved Modules— 2-Elements Fixed Coil :</i>		
Size & # of Turns of Each element	8" coil w / 5-Turns 6" coil w / 4-Turns	8" coil w / 5-Turns 6" coil w / 4-Turns
Right Front	8" Element @ 2100-Watts	8" Element @ 2100-Watts
Right Rear	6" Element @ 1250-Watts	6" Element @ 1250-Watts
Bowl Material	Chrome	Chrome
Approximate Weight	9 Lbs.	9 Lbs.
<i>Approved Modules—Grill:</i>		
Grill Grate	Black	Black
Grill Grate Finish	Whitford	Whitford
Dual Circuit Grill Element	Yes - 2800-Watts	Yes - 2800-Watts
Automatic Blower w / Grill	Yes	Yes
Approximate Weight	12 Lbs.	12 Lbs.
Accessory: Grill Cover	RCM50DB	RCM50DQ
Accessory: Griddle	RCM40DB	RCM40DB
<i>Approved Modules— 2-Element Radiant Ceran:</i>		
Quick-Start Series 7 Elements	Yes	Yes
Front	8" Element @ 1800-Watts	8" Element @ 1800-Watts
Rear	6" Element @ 1200-Watts	6" Element @ 1200-Watts
Glass Pattern	Whirlpool Design	Whirlpool Design
Warranty	1-Year Full — 5-Years Glass	1-Year Full — 5-Years Glass
Approximate Weight	11 Lbs.	11 Lbs.
<i>Approved Accessory:</i>		
Wall Vent Cap 3-1/4" x 10"	RCM3D	RCM3D
Wall Vent Cap 6" Round	RCM6D	RCM6D
Wall Vent Cap 5" Round	RCM5D	RCM5D
<i>Literature:</i>		
Use & Care Guide	4381591	4381591
Wiring Diagram	4381593	4381593
Installation Instructions	4381589	4381589

## Model RC8720EDB/W

<b>MODEL NUMBER</b>	<b>RC8720EDB</b>	<b>RC8720EDW</b>
<i>Cooktop Colors:</i>		
Perimeter Finish	Porcelain Black	Porcelain White
Control Panel	Black	White
Control Panel Graphics	White	Ascot Grey
Control Panel Accents	Persimmon Red	Persimmon Red
Air Grille	Black	White
<i>Dimensions (Inches):</i>		
Overall Width	29-7/8	29-7/8
Overall Depth	21-1/2	21-1/2
Cutout Width	28-7/8	28-7/8
Cutout Depth	20-7/8	20-7/8
Blower Assembly Clearance (Below Countertop)	16-7/16	16-7/16
<i>Cooktop Features:</i>		
Right Bay	2-Elements—Fixed Coil	2-Elements—Fixed Coil
Left Bay	Open	Open
2-Elements Fixed Coil (Right Bay)	8" Coil with 5-Turns 6" Coil with 4-Turns	8" Coil with 5-Turns 6" Coil with 4-Turns
Right Front	8" Element @ 2100-Watts	8" Element @ 2100-Watts
Right Rear	6" Element @ 1250-Watts	6" Element @ 1250-Watts
Number of Bays Convertible	Single Convertible	Single Convertible
Control Location	Right Side	Right Side
Indicator Light	On/Off	On/Off
Removable Coils & Bowls	Yes	Yes
Control Type	Standard Mechanical	Standard Mechanical
Bowl Material	Chrome	Chrome
Blower	300 CFM	300 CFM
Blower Switch	On/Off Dial	On/Off Dial
<i>Other Specifications:</i>		
Total Connected Load	7.7 kW	7.7 kW
Electrical Requirements	32.1 Amp Circuit	32.1 Amp Circuit
Junction Box w/o Power Cord	Yes	Yes
Warranty	1-Year Full — 2-Year Parts	1-Year Full — 2-Year Parts
Approximate Weight	53 Lbs.	53 Lbs.
Agency Approval	U.L. - C.S.A.	U.L. - C.S.A.



<b>MODEL NUMBER</b>	<b>RC8720EDB</b>	<b>RC8720EDW</b>
<i>Approved Modules:</i>		
2-Elements Fixed Coil Module	RCM10DB	RCM10DQ
2-Elements Radiant Ceran	RCM30DB	RCM30DQ
Grill (Left Bay Only)	RCM20DB	RCM20DB
<i>Approved Modules— 2-Elements Coil:</i>		
	RCM10DB	RCM10DQ
Size & # of Turns of Each element	8" Coil w / 5-Turns 6" Coil w / 4-Turns	8" Coil w / 5-Turns 6" Coil w / 4-Turns
Right Front	8" Element @ 2100-Watts	8" Element @ 2100-Watts
Right Rear	6" Element @ 1250-Watts	6" Element @ 1250-Watts
Bowl Material	Chrome	Chrome
Approximate Weight	9 Lbs.	9 Lbs.
<i>Approved Modules—Grill:</i>		
	RCM20DB	RCM20DB
Grill Grate	Black	Black
Grill Grate Finish	Whitford	Whitford
Dual Circuit Grill Element	Yes - 2800-Watts	Yes - 2800-Watts
Automatic Blower w / Grill	Yes	Yes
Approximate Weight	12 Lbs.	12 Lbs.
Accessory: Grill Cover	RCM50DB	RCM50DQ
Accessory: Griddle	RCM40DB	RCM40DQ
<i>Approved Modules— 2-Element Radiant Ceran:</i>		
	RCM30DB	RCM30DQ
Quick-Start Series 7 Elements	Yes	Yes
Front	8" Element @ 1800-Watts	8" Element @ 1800-Watts
Rear	6" Element @ 1200-Watts	6" Element @ 1200-Watts
Glass Pattern	Whirlpool Design	Whirlpool Design
Warranty	1-Year Full — 5-Years Glass	1-Year Full — 5-Years Glass
Approximate Weight	11 Lbs.	11 Lbs.
<i>Approved Accessory:</i>		
Wall Vent Cap 3-1/4" x 10"	RCM3D	RCM3D
Wall Vent Cap 6" Round	RCM6D	RCM6D
Wall Vent Cap 5" Round	RCM5D	RCM5D
<i>Literature:</i>		
Use & Care Guide	4381591	4381591
Wiring Diagram	4381593	4381593
Installation Instructions	4381589	4381589

# MODEL NUMBER DESIGNATION

<b>MODEL NUMBER</b>	R	C	8	7	0	0	E	D	B	0
<b>INTERNATIONAL SALES IND.</b> OR MARKETING CHANNEL, IF PRESENT										
<b>PRODUCT GROUP</b> R = ELECTRIC S = GAS										
<b>PRODUCT IDENTIFICATION</b> A = ACCESSORY      H = HOODS C = COOKTOP        K = KITS E = EYE-LEVEL      S = SET-INS F = FREESTANDING										
<b>MODEL SIZE</b> 0 = 20" OR 24" FREESTANDING 1 = 24" OR 27" BUILT IN OVEN 3 = 30" FREESTANDING 4 = 40" FREESTANDING 5 = 36" FREESTANDING 6 = 30" SET-IN RANGES 8 = BUILT-IN COOKTOPS 9 = EYE-LEVEL DOUBLE OVEN										
<b>OVEN TYPE (DOES NOT APPLY TO COOKTOPS)</b> 0 THRU 1 = STANDARD PORCELAIN 2 THRU 5 = CONTINUOUS CLEAN 6 THRU 9 = PYROLYTIC SELF-CLEAN										
<b>FEATURE / VARIATIONS</b> 3 = SEALED BURNER GLASS TOP 4 = BUILDER - CERAMIC COOKING SURFACE 5 = HIGH SPEED COIL ELEMENT 6 = RETAIL - CERAMIC COOKING SURFACE 7 = SOLID ELEMENT WITHOUT TOUCH CONTROL 8 = OPEN COIL ELEMENTS WITH TOUCH CONTROL 9 = SOLID ELEMENTS WITH TOUCH CONTROL										
<b>DOOR TYPE (DOES NOT APPLY TO COOKTOPS)</b> B = SOLID BLACK GLASS O = METAL OVEN DOOR P = WINDOW BLACK GLASS										
<b>FEATURE CODE</b> E = ELECTRONIC IGNITION (GAS ONLY) S = STANDING IGNITION (GAS ONLY) C = COLOR COORDINATED GLASS X = NOT DEFINED										
<b>YEAR OF INTRODUCTION</b> D = 1995 E = 1996										
<b>COLOR CODE</b> B = BLACK Q = WHITE										
<b>ENGINEERING CHANGE (0, 1, 2, ETC.)</b>										



## WHIRLPOOL ELECTRIC MODULAR DOWNDRAFT COOKTOP WARRANTY

<b>LENGTH OF WARRANTY</b>	<b>WHIRLPOOL WILL PAY FOR:</b>
<b>ONE YEAR FULL WARRANTY</b> From Date of Installation.	FSP® replacement parts and repair labor costs to correct defects in materials or workmanship. Service must be provided by an authorized Whirlpool service company.
<b>WHIRLPOOL WILL NOT PAY FOR:</b>	
A. Service calls to: <ol style="list-style-type: none"> <li>1. Correct the installation of the cooktop.</li> <li>2. Instruct you how to use the cooktop.</li> <li>3. Replace house fuses or correct house wiring.</li> </ol>	
B. Repairs when cooktop is used in other than normal, single family home use.	
C. Pickup and delivery. This product is designed to be repaired in the home.	
D. Damage to the cooktop resulting from accident, misuse, fire, flood, acts of God, or use of products not approved by Whirlpool.	
E. Repairs to the ceramic cooktop if it has not been cared for as recommended in the Use And Care Guide.	
F. Repairs to parts or systems caused by unauthorized modifications made to the appliance.	

**WHIRLPOOL CORPORATION SHALL NOT BE LIABLE FOR INCIDENTAL OR CONSEQUENTIAL DAMAGES.** Some states do not allow the exclusion or limitation of incidental or consequential damages, so this exclusion or limitation may not apply to you.

This warranty gives you specific legal rights, and you may also have other rights which vary from state-to-state.

**Outside the United States, a different warranty may apply. For details, please contact your authorized Whirlpool dealer.**

If you need service, first see the "Assistance or Service" section of the Use and Care Guide. After checking "Assistance or Service," additional help can be found by calling our Consumer Assistance Center telephone number, **1-800-253-1301**, from anywhere in the U.S.A.

— NOTES —