

GE Appliances

# Technical Service Guide

October 2015

## GE CleanSpeak™ Wi-Fi Connect Top Load Washer

GTW810SSJWS  
GTW810SPJMC  
GTW860SSJWS  
GTW860SPJMC

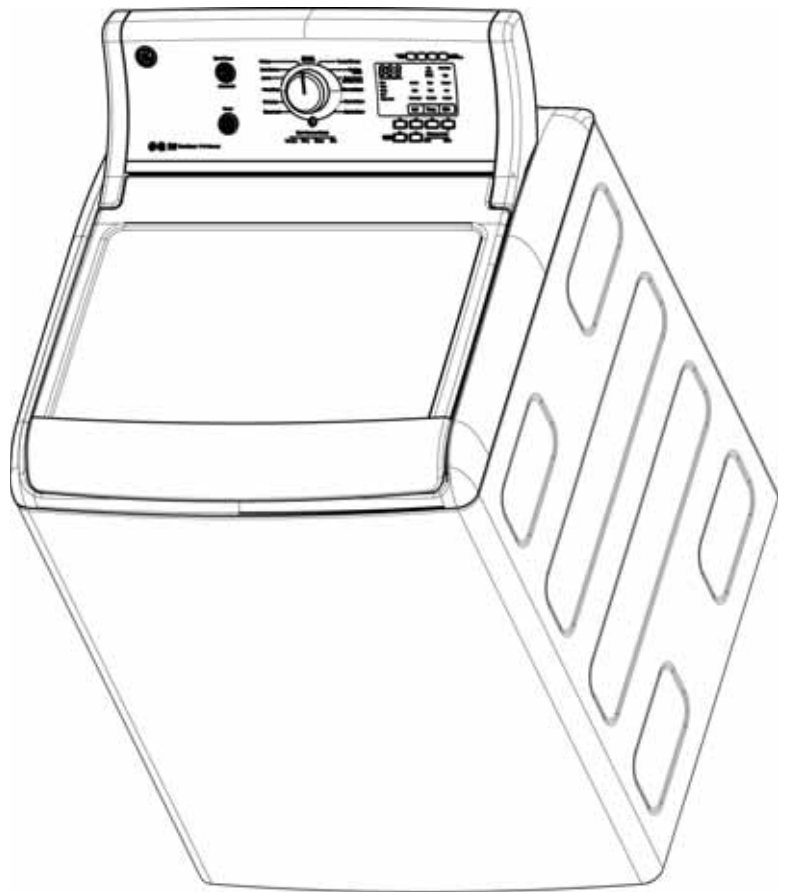

GE Appliances  
General Electric Company  
Louisville, Kentucky 40225

31-9245

# Safety Information



## Important Safety Notice

The information in this service guide is intended for use by individuals possessing adequate backgrounds of electrical, electronic, and mechanical experience. Any attempt to repair a major appliance may result in personal injury and property damage. The manufacturer or seller cannot be responsible for the interpretation of this information, nor can it assume any liability in connection with its use.

## Warning

To avoid personal injury, disconnect power before servicing this product. If electrical power is required for diagnosis or test purposes, disconnect the power immediately after performing the necessary checks.

## Reconnect all Grounding Devices

If grounding wires, screws, straps, clips, nuts, or washers used to complete a path to ground are removed for service, they must be returned to their original position and properly fastened.

## GE Appliances

*Technical Service Guide*

*Copyright © 2015*

All rights reserved. This service guide may not be reproduced in whole or part in any form without written permission from the General Electric Company.

# Table of Contents

Safety Requirements .....	5
Introduction .....	6
Nomenclature .....	8
Product Specifications.....	9
Electrical Specifications .....	9
Tools Needed.....	10
Model Graphics .....	11
Component Locator Views .....	12
Underside Top Cover 860 .....	12
Underside Top Cover 810 .....	13
Tub Basket.....	14
Basket Assembly .....	15
Control Panel.....	16
Bottom .....	17
Operation .....	18
Operating Controls.....	18
Redistribution Attempts.....	24
Cycle Chart .....	25
Diagnostics .....	28
Service Mode.....	28
Additional Diagnostics.....	31
H2O Supply Message .....	31
Fault Codes.....	32
Explaining 0D and D3 Fault Codes .....	42
Explaining 0D and D3 Fault Codes Shown at the Same Time.....	44
Diagnostic Testing Visual Symptoms with 2.XX and or 4.XX Software .....	46
“SEnSE” is Scrolling in the Display/No Display .....	48
Cabinet and Structure .....	49
Backsplash.....	49
UI Logic Board.....	51
Inverter Machine Control (IMC) Board.....	52
Lid Assembly .....	54
Hinges.....	55
Top Cover.....	56
Lid Lock .....	57
LED Tub Light.....	60
Rear Panel .....	61

Leveling Legs .....	62
Impeller Assembly .....	63
Suspension System.....	64
Basket.....	67
Outer Tub .....	68
Drive System .....	69
Rotor .....	69
Stator .....	70
Hall Sensor .....	71
Mode Shifter .....	72
Platform Assembly.....	75
Fill System.....	78
Water Valve Assembly .....	78
Pressure Sensor .....	81
Water Levels .....	82
Top Cover Dispenser Cups.....	83
Bulk Dispenser Tanks.....	85
Bulk Tank Pressure Sensors .....	88
Tub Thermistor .....	91
Wash System.....	93
Recirculation Pump .....	93
Recirculation Tube .....	94
Drain System .....	95
Drain Pump .....	95
Drain Hose .....	96
Schematics .....	97
GE Top Load Washer Warranty .....	99

# Safety Requirements

GE Factory Service Employees are required to use safety glasses with side shields, safety gloves & steel toe shoes for all repairs.



## ⚠ WARNING

Prior to disassembly of the washer to access components, GE Factory Service technicians are REQUIRED to follow the Lockout / Tagout (LOTO) 6 Step Process:

<p><b>Step 1</b> Plan and Prepare</p>	<p><b>Step 4</b> Apply LOTO device and lock</p>
<p><b>Step 2</b> Shut down the appliance</p>	<p><b>Step 5</b> Control (discharge) stored energy</p>
<p><b>Step 3</b> Isolate the appliance</p>	<p><b>Step 6</b> “Try It” verify that the appliance is locked out</p>

# Introduction

## **MAKE STAINS HOWEVER YOU LIKE. WE'LL MAKE WASHING THEM SIMPLE.**

Getting messy is still fun. We make clean-up easier with new and innovative features such as our Stain Removal Guide, designed to fight common stains with the push of a button.

GE's CleanSpeak™ Top Load Washer features and appearance may vary depending upon model.

- **SmartDispense™ TECHNOLOGY**

Never measure detergent again. The washer can hold about a two-month supply of detergent and fabric softener, and can automatically dispense the right amount for each load. The preferred amount for each load can be adjusted. Check the indicator to see when to refill the detergent and fabric softener.

- **STAIN REMOVAL GUIDE**

Remove stains with the push of a button. The Stain Removal Guide is pre-programmed with the ideal wash settings to tackle four common stains: tomato, oil, dirt and grass.

- **SOFT-CLOSE GLASS LID**

Our Soft-Close Lid uses hydraulic technology to allow the lid to open to various angles, and then close gently every time.

- **TINTED GLASS LID**

See what's going on inside the washer. The tinted glass lid lets you take a peek inside without opening the washer mid-cycle.

- **LED WASHER BASKET LIGHT**

Find every last sock with a bright LED light that effectively lights the wash basket

- **CLEAN SPEAK COMMUNICATION SYSTEM**

Perfect drying performance is achievable thanks to the ability of the washer to communicate with the dryer to preset the dry cycle.

- **QUIETPACK**

Enjoy a powerful clean that you won't hear thanks to noise dampening material that holds in sound for a quieter cycle.

- **VIBRATION CONTROL**

Wash without the shake. Quietly washes any size load without vibration thanks to technology that optimizes spin pattern.

- **ENERGY EFFICIENT**

ENERGY STAR® qualified and CEE Tier III meets or exceeds federal guidelines for energy efficiency for year-round energy and money savings.

- **eMonitor**

Get the energy saving insight you need to reduce your utility bills with an electronic readout that shows the efficiency level of each load.

- **eWash™**

Energy saving option uses a cold water wash on select cycles without sacrificing performance.

- **FLEXIBLE CAPACITY**

Take clean further with large, flexible capacity. GE's largest capacity top load washer and dryer help you get more laundry done in less time.

- **DEEP TUB ACCESS**

Easily reach the bottom. Deep tub access offers an ergonomically designed wash basket opening so anyone can easily reach the bottom.

- **PERSONALIZED SETTINGS**

With My Settings, you can wash and dry your clothes with the settings you prefer on any cycle, and save them as favorites.

- **Wi-Fi CAPABILITY**

Control your washer from your computer or smart phone.

- **OXI SANITIZE CYCLE**

When combined with detergent, an Oxi laundry additive performs a concentrated prewash sanitation step, followed by a hot water wash. This cycle is designed to remove 99.9% of bacteria found in home laundry.

<b>NOTICE</b>
The default <b>Sanitize With Oxi</b> cycle water temperature (Hot) can NOT be changed.

# Nomenclature

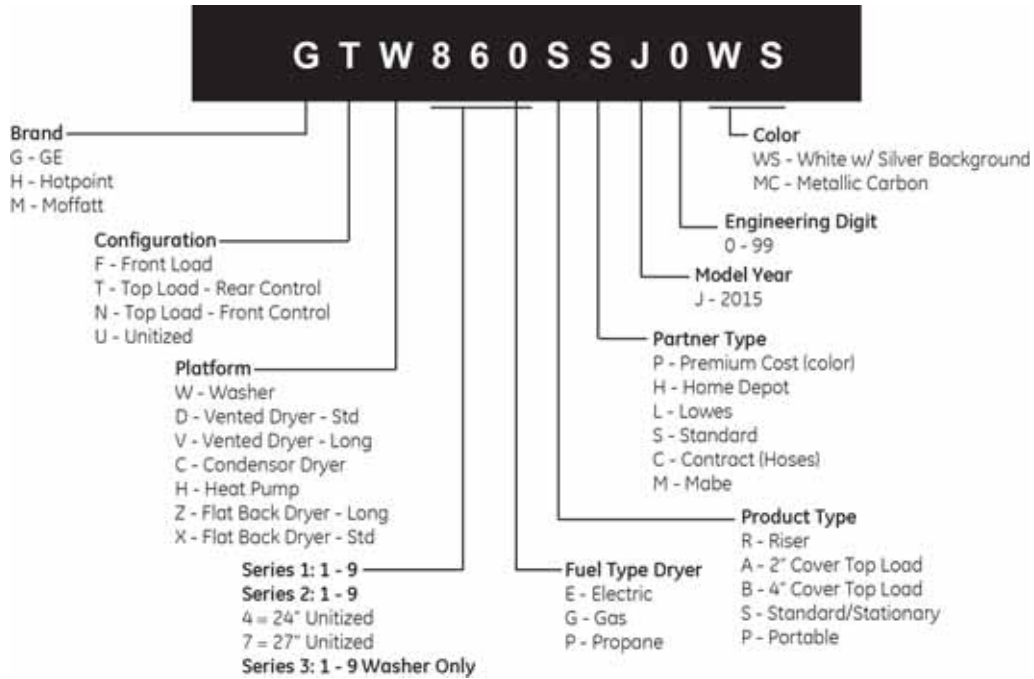

## Serial Number

The nomenclature breaks down and explains what the letters and numbers mean in the model number. The first two characters of the serial number identify the month and year of manufacture. Example: LA123456S = June, 2013

A – JAN	2024 – Z
D – FEB	2023 – V
F – MAR	2022 – T
G – APR	2021 – S
H – MAY	2020 – R
L – JUN	2019 – M
M – JUL	2018 – L
R – AUG	2017 – H
S – SEP	2016 – G
T – OCT	2015 – F
V – NOV	2014 – D
Z – DEC	2013 – A

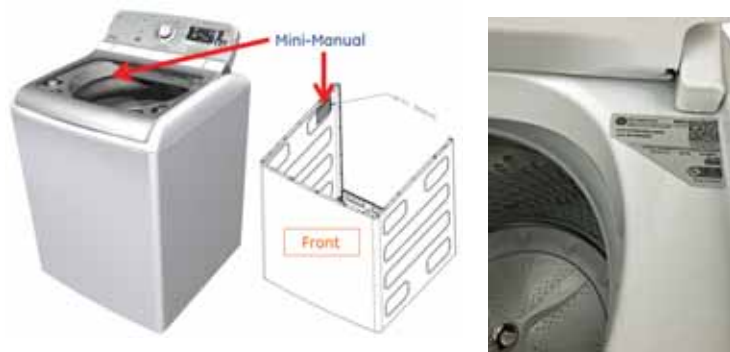

The letter designating the year repeats every 12 years.

The Model Serial ID Tag is located on the top cover, under the lid near the right rear hinge cover.

The Mini Manual is in a storage bag on the inside left rear of the outer wrapper. Push down on the tub to access.



# Product Specifications

## Electrical Specifications

### AC Voltage

- Inverter board: 120 VAC to the J101
- Recirculation Pump: Should read approximately 30.5 ohms - 120 VAC
- Drain Pump: Should read approximately 16.5 ohms - 120 VAC
- Mode Shifter Motor: Should read approximately 4k ohms - 120 VAC
- Water Valves: Should read approximately 1k ohms – 120 VAC

### DC Voltage

- UI Logic Board: 12 VDC / 7.5 VDC
- Lid Lock Position Locked/Unlocked: 5 VDC
- Tub Light: 3.8 VDC
- Testing the Hall Sensor: 12 VDC

**CAUTION: Potential of -170 VDC from Earth Ground to “P”**

### NOTICE

Terminal “P” at the J1001 connector on the IMC board is referred to as “V” on the mini manual.

### CAUTION

FOR ELECTROSTATICS, be sure to make an earth ground connection before replacing any electronic components to prevent electrostatic damage to them. This is done by touching a good earth ground on the appliance being repaired.

# Tools Needed

The following specialized tools are referenced within this Service Guide and may be ordered from GE.

## Specialized Tools

### WX05X10022 Socket

This is not an ordinary impact socket. This is a shallow wall deep well 1-5/16 impact socket, used to remove the washer hub nut.



### WX05X10025 Click Pliers

The click pliers can be used for removing the factory installed clamps on all of the washer tube connections. These can also be used to install the click clamps.



### WX05X10028 Torque Limiter

The torque limiter tool is used with an impact gun to achieve the proper torque.

**NOTE:** Use the torque limiter when removing or installing the hub nut to prevent damage to the shaft and tube assembly.



## Standard Tools

- 1/4" Nut driver
- 5/16" Nut driver
- 3/8" Socket
- 7/16" Socket
- 1/2" Socket
- 11/16" Socket
- 10mm Wrench or deep well socket
- Electric impact gun
- Inch lb Torque wrench
- Foot lb Torque wrench
- T15 Torx bit
- Putty knife
- Multimeter (that can measure frequency)
- Needle nose pliers

# Model Graphics



**GTW810S**



**GTW860S**

# Component Locator Views

## Underside Top Cover 860

### Underside Top Cover Of 860 Bulk Dispense Model

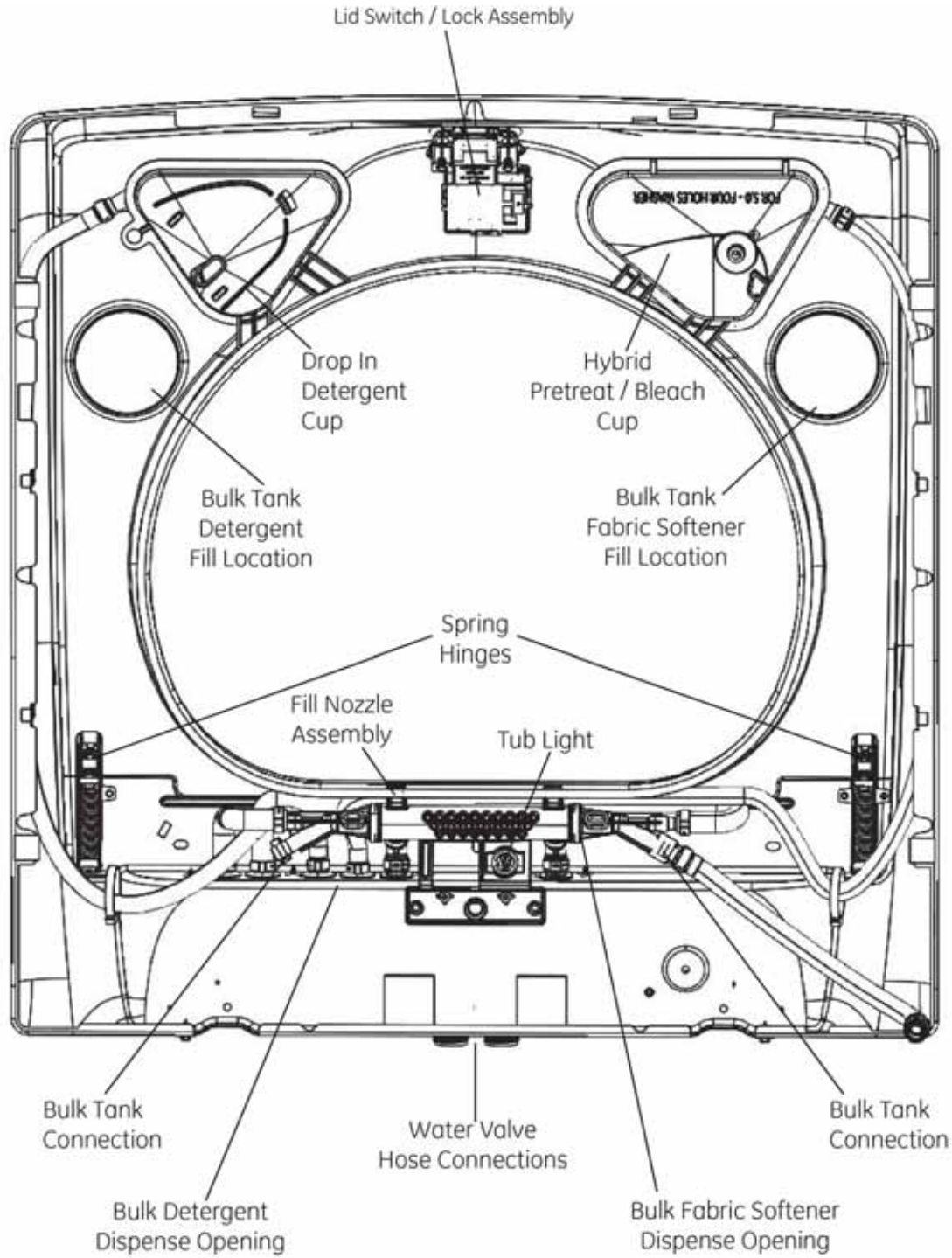

# Underside Top Cover 810

## Underside Top Cover Of 810 Bulk Dispense Model

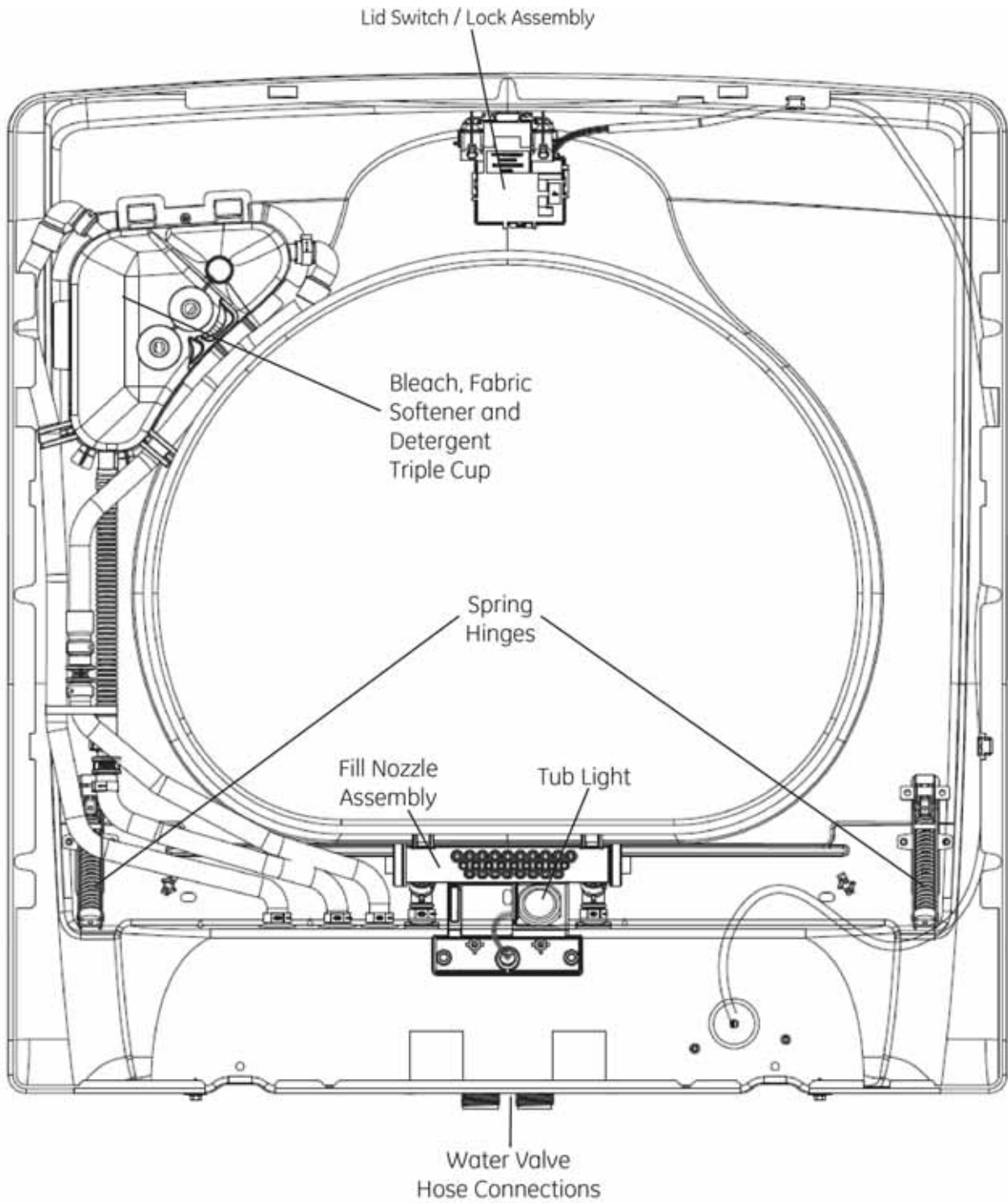

# Tub Basket

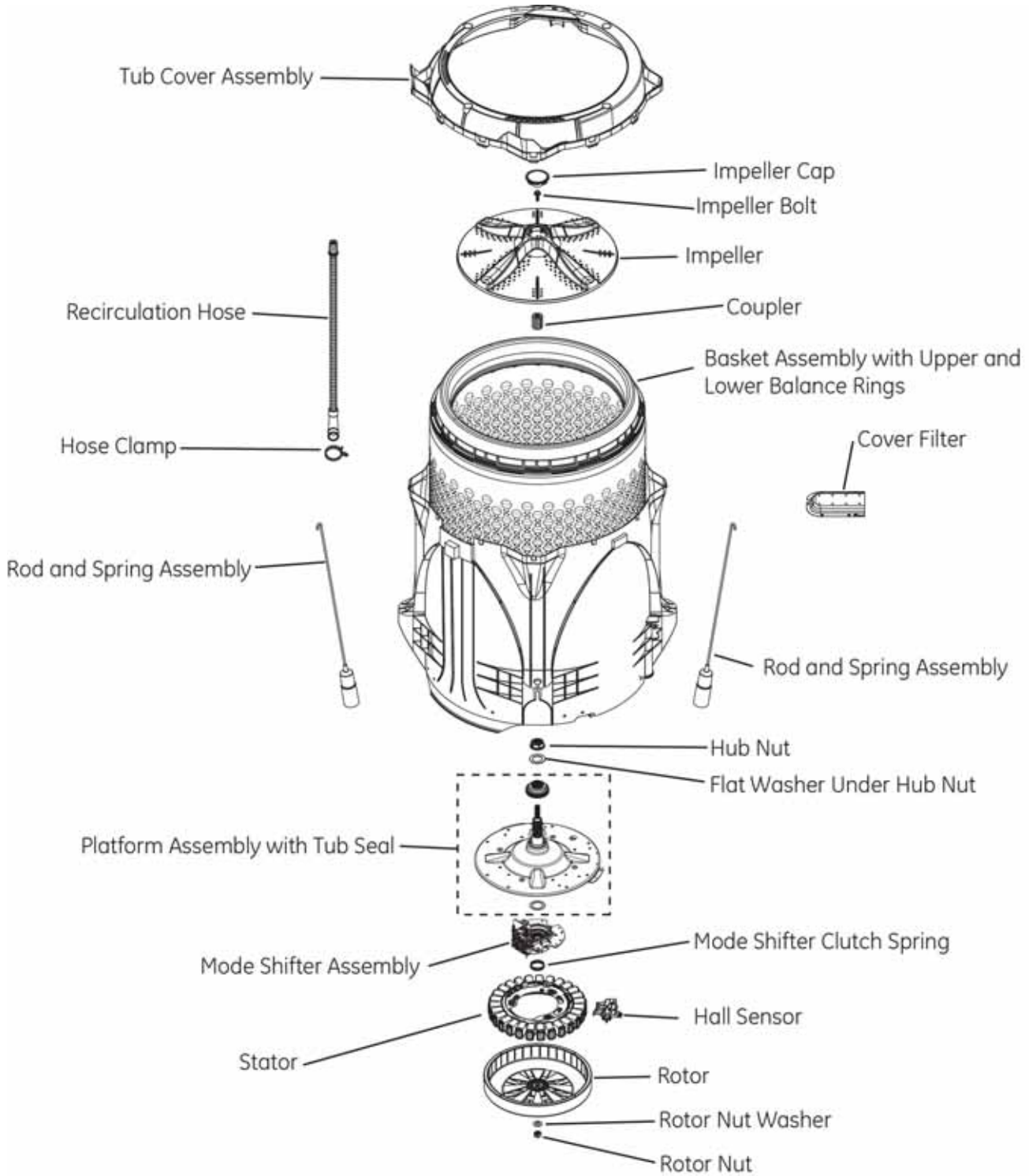

# Basket Assembly

\* This comes as a complete assembly.

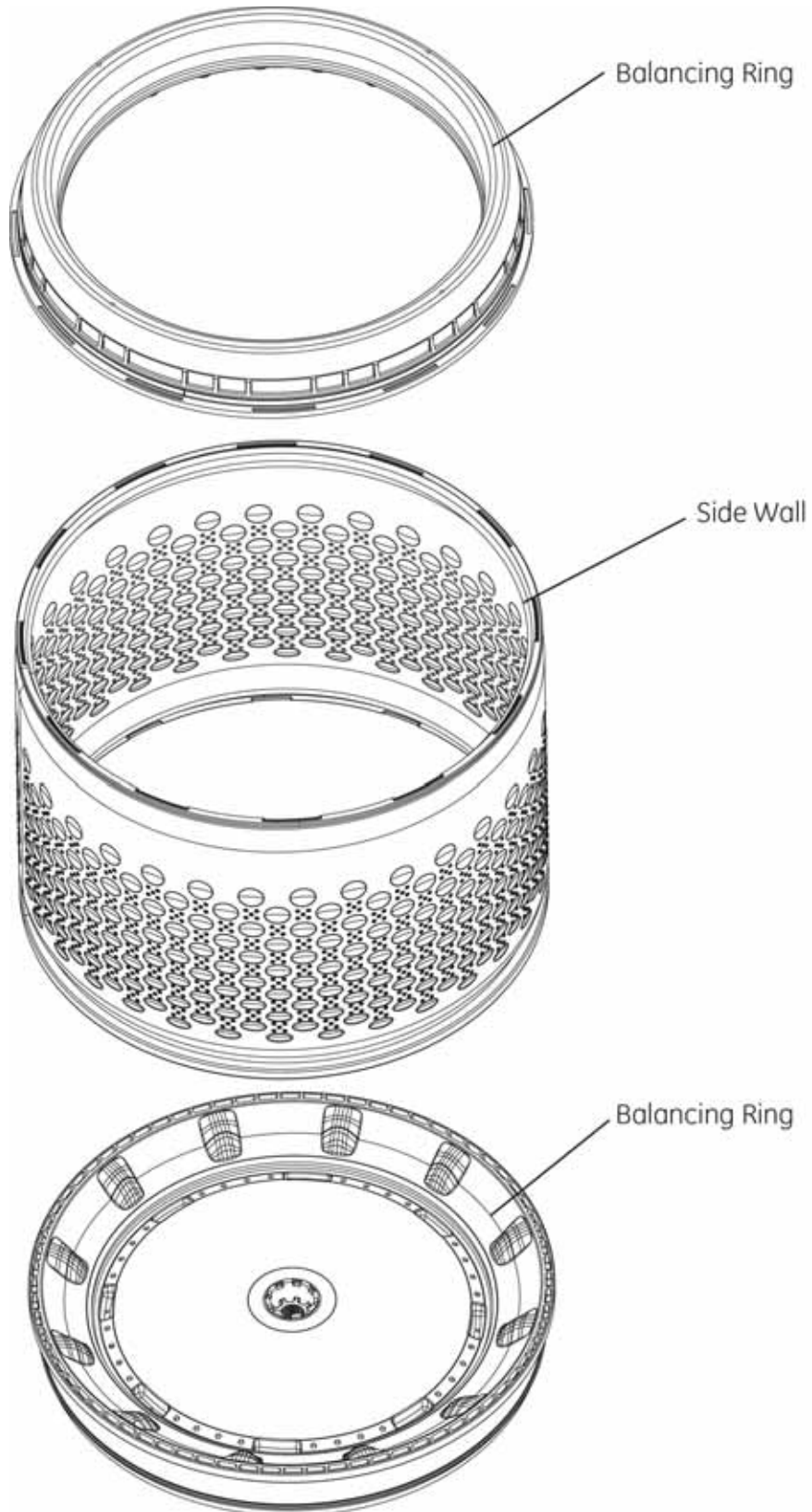

# Control Panel

\* The ACM Module is also referred to as RJ-45.

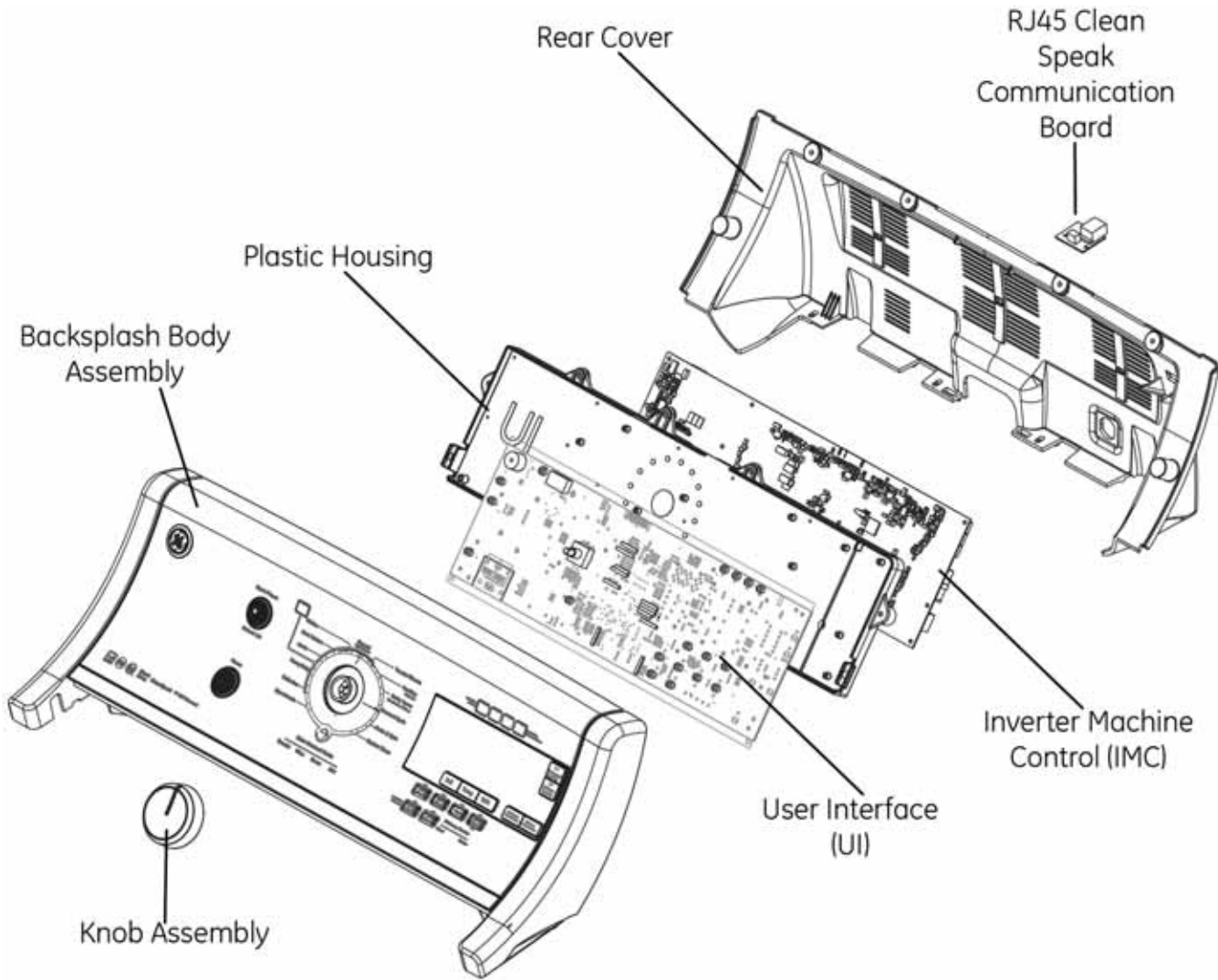



# Bottom

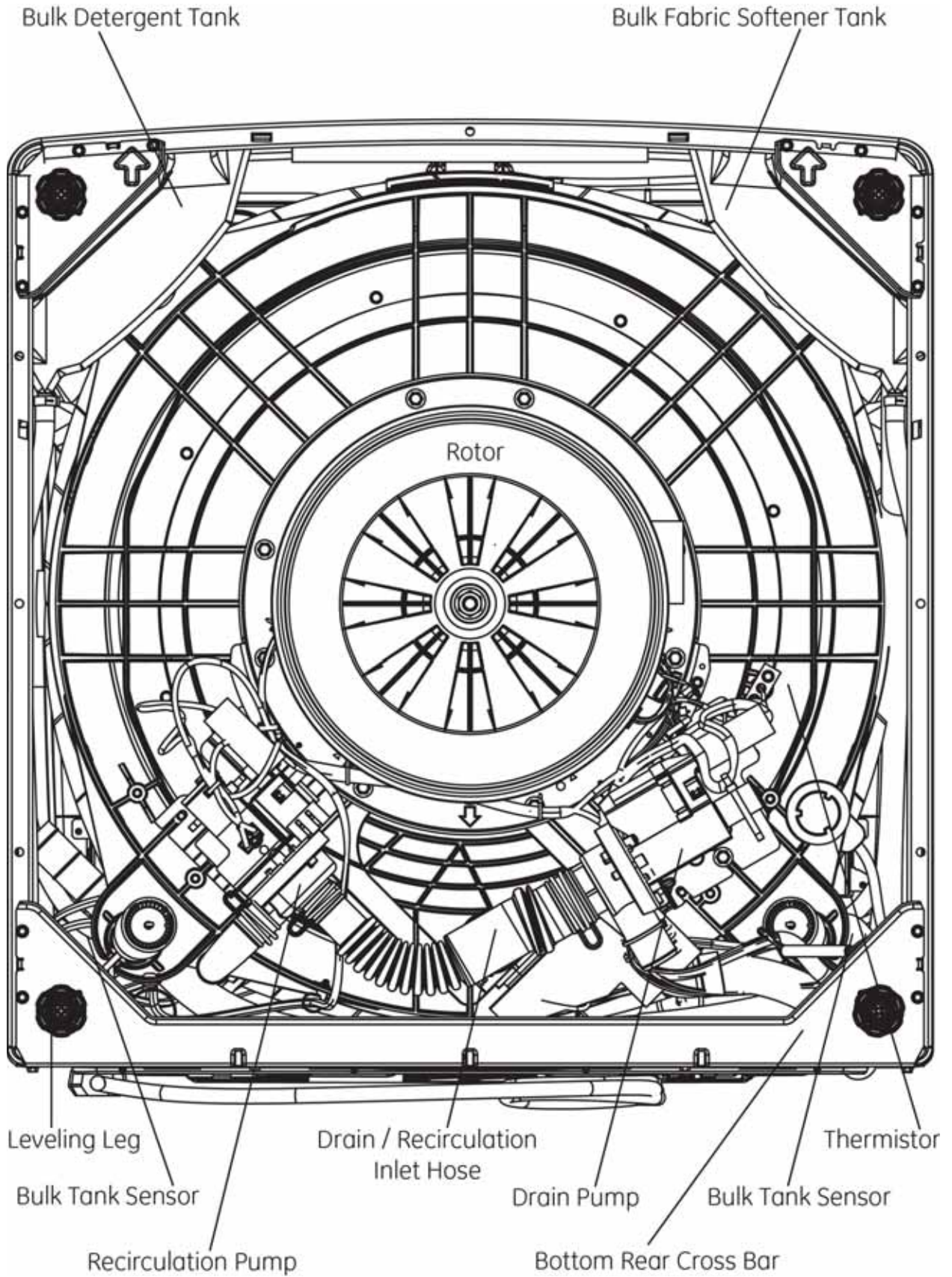

# Operation

## Operating Controls

\*Some features may not be available on all models.

### Controls

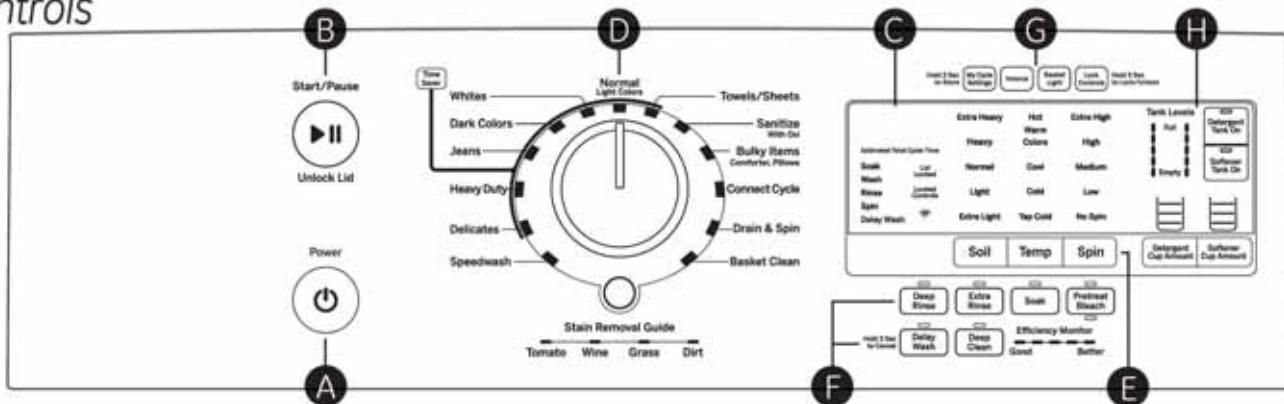

#### A Power

Press **Power** to “wake up” the display. If the display is active, press **Power** to put the washer into idle mode.

**NOTE:** Pressing **POWER** does not disconnect the appliance from the power supply.

#### B Start and Unlock Lid

Press **Start** to begin the cycle. The lid must be closed for the washer to fill and the cycle to start. If the lid is open, “LID” will scroll across the display. If the lid is closed, the lid will lock, the **LID LOCKED** light will light, the detergent will be dispensed, and “FILL” will scroll across the display.

Pressing **Unlock Lid** will **Pause** the cycle and the **Start** indicator light will blink.

To continue the cycle, press **Start** again. If machine is paused more than 24 hours, the cycle will be cancelled. If water remains in the machine, select the **Drain & Spin** cycle to drain tub and spin water out of the washer tub.

## C Display and Status Lights

### Display:

The display shows the **approximate** time remaining until the end of the cycle.

**NOTE:** The cycle time is affected by how long it takes the washer to fill. This depends on the water pressure in the home. The “smart” timer “learns” the amount of time it takes to fill the washer and adjusts the total time accordingly.

### In addition, this display will scroll the washer status:

- **bALANCINGg**: Start of rebalancing cycle to redistribute clothes. Stops after rebalancing is complete.
- **CyCLE PrEP**: Sensing dry load size prior to fill (normal).
- **dELAY**: Appears when **Delay Wash** is initiated. Replaced with estimated time when cycle starts.
- **End**: End of current cycle.
- **ES**: Washer in a delay start (4 hour maximum) awaiting lower energy rates (see the **Energy Smart** section in the Owners Manual Use & Care book).
- **FILL**: For the first 45 seconds of a fill, the estimated end of cycle time is displayed. For the rest of the fill time, “FILL” is scrolled until the fill completes.
- **H2O SUPPLY**: Cannot sense water level (house water supply possibly turned off). This will be displayed if the flow rate is less than 1 gallon per minute for 9 minutes.
- **HEAT**: Water being heated for **Sanitize** cycle.
- **Lid Cycle**: Stopped because lid is open. Close the lid.
- **LOAD SenSE**: Sensing wet load size (normal).
- **PAUSE**: Cycle paused because the **Start/Pause** button was pressed and the washer was set to **Pause**. Press **Start** button again to restart the cycle.

### Cycle status lights:

Shows whether the washer is in the **SOAK, WASH, RINSE** or **SPIN** cycle.

**Feature status lights indicate** (see sections **F, G** and **H** for more details):



The **My Settings** feature is on for this cycle.



The lid is locked. See the **Control Lock** description in **G Additional Options**.



The washer is locked - will blink once if any button is pressed or if the cycle knob is turned.



The **eWash** feature is selected.



The signal is on. See the **Variable Signal** description in **G Additional Options**.



A **Delay Wash** time is set.



The **Energy Smart** feature is selected. See **About Appliance Communication** section in the Owners Manual Use & Care book.

---

## D Wash Cycles-Cycle Selector Knob

The wash cycle controls the type of washing process. The Cycle Selector knob can be turned in either direction. Turning the knob after starting a cycle will stop the washer and change the cycle/ options to the new selection. Press **Start** to begin the new cycle selection.

**NOTE:** When the knob is turned to another cycle, the tub light is turned on to assist in loading.

The chart below will help match the wash cycle setting with the clothing load. **\*Cycles available with Steam Assist**

---

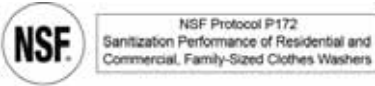
<b>Speedwash</b>	For small loads of lightly soiled items that are needed in a hurry. Provides light wash/rinse and short high speed spin.
<b>Delicates</b>	For lingerie and special-care fabrics with light to normal soil. Provides light wash and low speed spin.
<b>Hand Wash*</b>	For items labeled hand washable with light soils. Provides an extra light wash and medium speed spin.
<b>Jeans*</b>	For washing medium to lightly soiled jeans. Provides normal wash and medium speed spin. (For heavily soiled work jeans, use Whites cycle.)
<b>Dark Colors*</b>	For non-colorfast cottons and blends or items that are labeled cold wash. Provides normal wash and medium speed spin.
<b>Whites*</b>	For heavy to lightly soiled whites, household linens, work and play clothes. Provides a heavy wash and a high speed spin.
<b>Normal/Light Colors*</b>	For heavy to lightly soiled colorfast cottons, household linens, work and play clothes. This cycle provides the best overall cleaning and should be used for most everyday items. Provides normal wash and medium speed spin.
<b>Towels/Sheets*</b>	Provides periods of agitation and soak tailored for washing towels and sheets. Provides normal wash and a high speed spin.
<b>Sanitize</b>	When selecting sanitize, the washer increases the water temperature to sanitize and remove 99.9% of bacteria found in home laundry. Provides an extra heavy wash and a medium spin.
	
<b>Bulky Items/ Comforters, Pillows</b>	For large coats, bed spreads, mattress covers, sleeping bags and similar large and bulky items. Large items such as blankets, comforters, jackets and small rugs. Provides a normal wash and an extra heavy spin.
<b>Quick Rinse</b>	Rinses and spins non-soiled items where a rinse only is desired. Provides an extra light wash and an extra high speed spin. Fabric Softener and Extra Rinse options are available with this cycle.
<b>Drain &amp; Spin</b>	For draining the tub and spinning water out of the clothes. Provides a normal wash and a medium speed spin.

---

---

## BASKETclean

Use for cleaning the basket of residue and odor. The washer will fill with hot water. Use this cycle once a month with liquid chlorine bleach or Tide® Washing Machine Cleaner. **NOTE:** Never load laundry while using **BASKETclean**. The laundry may become damaged or contaminated.

---

## Steam Assist



Steam Assist adds steam into the washer during Hand Wash, Jeans, Dark Colors, Whites, Normal/Light Colors and Towels/Sheets cycles. This helps to loosen stains for better washability.

To use:

1. Turn Power on and select one of the wash cycles.
  2. Press the Steam Assist button to activate.
  3. Press the Start button.
- 

## Stain Removal Guide



The **Stain Removal Guide** feature allows the user to indicate what stains are on the garments in the load. This feature can be used with any wash cycle except **Sanitize**.

**To use Stain Removal Guide:**

1. Select the wash cycle.
2. Press the Stain Removal Guide button (the button will light up when it is on).

Continue to press to select tomato stain, oily stain, grass stain or dirt stain. The indicator light will show the selected stain.

To select a different stain, press the Stain Removal Guide button until desired stain to be removed is lit.

To turn off Stain Removal Guide, press until the light on the button turns off.

**NOTE:** The Soil and Temperature levels will be changed to match each stain type. Turning off Stain Removal Guide will return the settings to default.

## E Settings

Individual settings for agitation (Soil), water temperature (Temp), and spin (Spin) can be set from the minimum (lowest in column) to maximum (highest in column). In general, the higher up the column, the more washer energy will be used.

**NOTE:** Higher Spin speeds typically reduce dryer time/energy usage (i.e.: reduces total energy when using both a washer and a dryer).

## **F Cycle Options**

### **Soak**

This option begins with a brief agitation, soaks for a specified period of time, then moves through the rest of the cycle automatically. Repeated pressing of the Soak button will add 15, then 30 and then return back to 0 soak minutes.

### **Extra Rinse**

When using extra detergent or bleach to clean heavily soiled clothes, use the Extra Rinse option to better remove additional residues.

**NOTE:** This option is not allowed for some cycles.

### **Deep Rinse**

Set this option to provide a deep rinse or when manually adding fabric softener to the rinse cycle.

**NOTE:** This option is not allowed for some cycles.

**NOTE:** This option is not allowed for some cycles.

### **Pretreat/Bleach**

Set this option to add pretreatment -OR- bleach in the next load. Press once to indicate adding pretreatment (light on above button), twice to specify bleach (light on below button), three times to turn off (no light). Pretreatment or bleach will be added at the optimal time during the wash cycle (differs for pretreatment or bleach).

**Do NOT use pretreatment and bleach in the same load. If user forgets to dispense (did not press button once or twice), they can flush out the dispenser by pouring water into the compartment and running a Quick Rinse cycle to remove from the tub.**

### **Delay Wash**

When the Delay Wash button is repeatedly pressed, the delay time is set from 1 (01H) to 9 (09H) hours and back to clear (00H) hours. If the Delay Wash is pressed and held for 3 seconds, it will immediately reset.

## G Additional Options

### My Settings

As the cycle selector knob is turned, the Soil, Temp and Spin settings change to automatic pre-set default settings. If user desires a different setting, select the desired options or changes to cycle settings. Press and hold the My Settings button for 3 seconds, the washer will save these settings for that cycle and the status heart and My Settings button will light when active. In the future, when the user turns the selector knob to that cycle, their settings will be automatically recalled. To temporarily (i.e.: for this load) return to the pre-set default settings, press the My Settings button for 1/2 second. The status heart and button lights will turn off and the options will change back to these defaults. To make these default settings permanent, hold the My Settings button again for 3 seconds to make them the preferred settings (the lights will turn back on). **NOTE:** My Settings includes Stain Removal Guide and Steam Assist but not Delay Wash or Variable Signal - or any bulk dispense options.

### Variable Signal

Use the Variable Signal button to change the volume of the end of cycle signal. Press the button until the desired volume is met (high, medium, low), or to off.

### Basket Light

The basket light will turn on when the Basket Light button is pressed, the lid is lifted, or the cycle knob is turned. It will stay on for 5 minutes or until the Basket Light button or Power button is pressed.

### Control Lock

The controls can be locked to prevent any selections from being made. Or the controls can be locked after a cycle has been started. Washer cannot be accidentally started by touching buttons with this option selected.

To lock the washer controls, press and hold the Control Lock button for 3 seconds. The control lock icon will light up when it is on.

To unlock the washer controls, press and hold the Control Lock button for 3 seconds.

**NOTE:** The Power button can still be used when the machine is locked.

## H eWash

When the eWash button is pressed, the cycle changes to its most energy efficient settings and all of the eMonitor lights will light to indicate that the most efficient settings are on. If the settings are changed, the eWash light will go off and the number of eMonitor lights will decrease (or increase) to indicate decreased (or increased) energy efficiency settings.

## I SmartDispense™

The SmartDispense™ feature allows the user to set their liquid h.e. (High Efficiency) detergent and/or softener dispensing preferences for their load. This feature can be used with any wash cycle, except for Quick Rinse, Drain & Spin and BASKETclean cycles.

The SmartDispense™ system automatically dispenses liquid h.e. (High Efficiency) detergent and/or concentrated liquid fabric softener into each cycle at the optimal times.

To utilize the SmartDispense™ dispensers, they must first be filled. Although any liquid h.e. (High Efficiency) laundry detergent and concentrated liquid fabric softener can be used in the SmartDispense™ system, all liquid h.e. (High Efficiency) detergents and concentrated liquid fabric softeners are not the same.

**CAUTION! Absolutely do not store liquid chlorine bleach, powder detergent, non-concentrated liquid fabric softener or other laundry additives in any of the tanks. Use only liquid detergent which has been specifically designed for use in High Efficiency washers.**

## Redistribution Attempts

The washer will only attempt to redistribute an out of balance load one time per cycle in the final spin up. The redistribution attempt consists of the follow sequence.

- The washer will try to reach the target spin speed five consecutive times. It will spin, then stop to let the clothes fall back to the bottom of the basket. Then it will attempt a second spin. This may occur up to five times, although it may not need to use all of the spin attempts if it reaches its target spin speed.
- If the washer cannot get to the target spin speed, it will stop, then fill the basket with water appropriate for the selected cycle load size. Once the filling is complete, the washer will switch to agitate to jog the clothes and redistribute the clothes in the basket. After this redistribution attempt is completed, the basket will drain the water. This step is considered the redistribution, not the spin attempts.
- The washer will then switch to spin again and make another attempt to reach the target spin speed. The target spin speed may be reached on the first attempt. However, if the target spin speed is not reached, it will go through another set of 5 sequential tries to reach the target spin speed. If it does not reach the target spin speed it will spin at the highest spin speed it was able to obtain. In this example, a customer may possibly report that their clothes came out wet.
- This process can add up to 30 minutes to the cycle.



# Cycle Chart

The information provided below is based on an example load filling the tub to just under the top balance ring. The **Control Display** will adjust the times according to load size and weight after the load **CyCLE PrEP**.

Example Cycle Chart — Dark Colors Selected		
Description (Start to Finish)	Control Display	Comments
<b>Settings:</b> Normal Soil, Cold Wash, Extra High Spin	101 (minutes)	Bulk Detergent and Bulk Softener on.  Tub light goes out after 5 minutes.
5 Second Safety Water Spray		Every time a load is started or restarted, after a short pause, the lid will lock and then a 5 second water safety spray will occur, then a load sense to recalculate the load.
Lid Lock		
Load Sense Dry, Spin 120 RPM	<b>CyCLE PrEP</b> (Scrolling)	
Water Fill, Spin 15 RPM	58	Control display reflects recalculated cycle time after load sense.
Wet Clothes Load Sense	<b>LOAD SenSE</b> (Scrolling)	
Water Fill	<b>FILL</b> (Scrolling)	Water valves cycle to obtain correct temperature.
Adds Detergent from Bulk Dispense	<b>FILL</b> (Scrolling)	
Stops Spin and Adds Water in Detergent Cup	<b>FILL</b> (Scrolling)	
Starts 15 RPM Spin Again — Continues Filling	<b>FILL</b> (Scrolling)	
Stops Fill and Spin	<b>SenSE</b> (Scrolling)	
Mode Shift to Agitation	<b>SenSE</b> (Scrolling)	While sensing, movement of the basket or agitator is normal to ensure proper clutch engagement.
Recirculation Pump and Agitation Starts	54	Agitation pushes the load up from the center to the outer

Example Cycle Chart — Dark Colors Selected		
Description (Start to Finish)	Control Display	Comments
		edge of the basket. Then pulls the clothes back to the center from the outer edge.
Recirculation Soak, Agitation Stops	<b>51</b>	Programmed soak.
Recirculation Pump Off, Soak	<b>49</b>	
Recirculation Pump On, Agitation Starts	<b>46</b>	
Recirculation Pump Off, Continues Agitation	<b>44</b>	
Recirculation Pump On, Continues Agitation	<b>40</b>	
Recirculation Pump Off, Agitation Stops	<b>SenSE</b> (Scrolling)	
Mode Shift To Spin	<b>SenSE</b> (Scrolling)	While sensing, movement of the basket or agitation is normal to ensure proper clutch engagement.
Drain Pump On	<b>34</b>	Will recalculate time for pump out.
450 RPM Spin	<b>33</b>	It is normal for the cabinet to be bumped during the initial spin while determining out of balance loads.
Spin Stops	<b>29</b>	
Add Fabric Softener, Continues Filling, 15 RPM Spin	<b>FILL</b> (Scrolling)	
Stops Fill and Spin	<b>SenSE</b> (Scrolling)	
Mode Shift To Agitation	<b>SenSE</b> (Scrolling)	While sensing, movement of the basket or agitator is normal to ensure proper clutch engagement.
Recirculation Pump On, Agitation Starts	<b>23</b>	
Recirculation Off, Continues Agitation	<b>21</b>	Agitation arc is smaller to even the clothes load.
Agitation Stops	<b>SenSE</b> (Scrolling)	
Mode Shift To Spin	<b>SenSE</b> (Scrolling)	While sensing, movement of the basket or agitator is normal to ensure

Example Cycle Chart — Dark Colors Selected		
Description (Start to Finish)	Control Display	Comments
		proper clutch engagement.
Drain Pump On	<b>19</b>	
Drain Pump On, Spin Starts	<b>18</b>	Ramps up to final spin speed (1,000 RPM with extra high spin selected).
Spin Stops	<b>1</b>	Coast to stop.
	<b>End</b> (Scrolling)	Communicates wash load information to the dryer (if Clean Speak communication is connected).

Cycle temperatures cannot be used to diagnose or determine proper operation of this machine. The only temperatures that can be checked are the incoming house water supply to the washer using service mode. For optimal hot water temperature from the machine, the house hot water supply should be at least 115°F degrees.

Actual Sanitize Cycle time (verses what is displayed) will vary based on temperature of the hot water supply from the house. This cycle at the time of publish is certified by the Nation Sanitization Federation under their test conditions. To view the standards set by the Nation Sanitization Federation, look on the web under NSF.org.

# Diagnostics

## Service Mode

### Field Service Mode

To enter into **Field Service Mode**, press and hold the **Start** pad while rotating the **Cycle Selection** knob 180 degrees (8 clicks) and then release the **Start** pad. The **Cycle Selection** knob is now used to control the test selection menu. The seven segment display will show the test number according to the knob position (Example: **01** is **Test 1**). Upon entering the **Service Mode**, the control will be in the test selection mode, and will display "00" on the Control Panel.

Rotating the knob **clockwise** will **increase** the test number. Rotating the knob **counterclockwise** will **decrease** the test number. Rotate the knob to select the desired test and press **Start** to begin test.

To stop the test and/or choose the next test, turn the knob.

To exit **Field Service Mode**, press the **Power** pad or unplug the unit. The control will also exit **Field Service Mode** after 30 minutes.

### Acronyms:

- UI – User Interface
- MC – Machine Control
- SSD – Seven Segment Display
- HEX – Hexadecimal (i.e.: 255 = FF)  
\*Hexadecimal is a formula the control displays the Fault code in.

Test No.	Test Function
00	LED and Lid Check
01	Model ID Number
02	UI Software Version
03	Hot Water Valve Check
04	XML Version
05	Cold Water Valve Check
06	MC Software Version
07	Detergent Flow-Through Test
08	Inverter Software Version
09	Fabric Softener Flow-Through Test
10	Bleach Flow-Through Test
11	Bulk Detergent Test
12	Bulk Fabric Softener Test
13	Agitate
14	Spin
15	Drain Pump Check
16	Recirculation Pump Check
19	Lid Lock Check
20	Washer Communication Test
21	UI Critical SW Version Check
22	MC Critical SW Version Check
23	Inverter Critical SW Version Check
24	Error Codes
25	Clear Error Codes
26	Clear EEPPROM

### **Test 00 – Lid and LED Check**

- When the Start pad is pressed, all LEDs and displays will be lit (should display “8:88”).
- When the lid is raised, all LED and displays will begin blinking indicating that the lid switch is reading open.

### **Test 03 – Hot Water Valve Check**

- When the Start pad is pressed, the hot water valve will open and the SSD will display an “H”.

### **Test 05 – Cold Water Valve Check**

- When the Start pad is pressed, the cold water valve will open and the SSD will display a “C1”.
- At any time during **Service Mode**, if the water level reaches the lower pressure sensor levels, the Extra Light LED will come on. When the water reaches the upper level, the Extra Light and Light LED lights come on.
- After all water tests fill to the upper level, it will continue filling to the overflow level set in the control logic. When the overflow level is reached, the water will shut off and the drain pump will turn on. The pump will turn off when the water drains to the upper level. To drain the rest of the water out, switch to the drain pump test.

### **Test 07 – Detergent Flow-Through Test**

- (This feature is optional and will give an invalid beep if the test is selected and the feature is not available.)
- When the Start pad is pressed, the detergent valve will turn on for 2 seconds, off for 2 seconds, and repeat.
- The SSD will display “C2”.

### **Test 09 – Fabric Softener Flow-Through Test**

- (This feature is optional and will give an invalid beep if the test is selected and the feature is not available.)
- When the Start pad is pressed, the fabric softener valve will turn on for 2 seconds, turn off for 2 seconds, and repeat.
- The SSD will display “C3”.

### **Test 10 – Bleach Flow-Through Test**

- (This feature is optional and will give an invalid beep if the test is selected and the feature is not available.)
- When the Start pad is pressed, the bleach valve will turn on for 2 seconds, off for 2 seconds, and repeat.
- The SSD will display “C4”.

### **Test 11 – Bulk Detergent Test**

- (This feature is optional and will give an invalid beep if the test is selected and the feature is not available.)
- When the Start pad is pressed, the bulk detergent valve will turn on for 2 seconds, off for 2 seconds, and repeat.
- The SSD will display “C5”.

### **Test 12 – Bulk Fabric Softener Test**

- (This feature is optional and will give an invalid beep if the test is selected and the feature is not available.)
- When the Start pad is pressed, the bulk fabric softener valve will open and the SSD will display “C6”.

### **Test 13 – Agitate**

- When the Start pad is pressed, the SSD will display “A”.
- The test will not begin until the lid is closed. When the lid is closed, the lid will lock.
- After the lid is locked, if a shift is necessary, the unit will shift to agitate. When the shift is complete, the unit will start agitating.

### **Test 14 – Spin**

- When the Start pad is pressed the SSD will display “S”.
- The test will not begin until the lid is closed. When the lid is closed the lid will lock.
- If a shift is necessary, the unit will shift to spin. When the shift is complete, (on older software versions), the unit will start spinning at (15 RPM) with the lid unlocked. On units with newer software versions, it will ramp up to top spin speeds with the lid locked.
- If the lid is opened during spin, the spin will stop and will resume when the lid is closed.

### **Test 15 – Drain Pump Check**

- When the Start pad is pressed the SSD will display “P1”.
- The drain pump will turn on until the test is ended.

### **Test 16 – Recirculation Pump Check**

- (This feature is optional and will give an invalid beep if the test is selected and the feature is not available.)
- When the Start pad is pressed the SSD will display “P2”.
- The recirculation pump will turn on until the test is ended.

### **Test 19 – Lid Lock**

- When the Start pad is pressed the lid will lock and the SSD will display “LC”.
- Pressing the Start pad again will unlock the lid and the SSD will display “UL”.
- The lid will also unlock when the test is exited.

### **Test 20 – Dryer Communication Test**

- When the Start pad is pressed the SSD will display “- -” for one second. If the units are connected properly, able to communicate, and a version number is found, the display will show the major and then minor software version number of the Dryer UI.
- If the version number is not found (for whatever reason) the washer control will give an invalid beep and return to the Test Selection Menu.
  - The control will repeat the major – minor display sequence until the user exits the test.

### **Test 24 –Error Codes**

- When the Start pad is pressed, the SSD will display the first fault code in a HEX format.
- Each press of the Start pad will advance to the next fault in the list.
- Faults will only be displayed if they have occurred at least once.

### **Test 25 – Clear Error Codes**

- When the Start pad is pressed the SSD will display “Er”.
- Pressing and holding the Start pad for 3 seconds will clear all fault codes and sound a valid tone and update the display to “- -”.
- On press and hold of the Start pad for 3 seconds the fault log will be cleared.

### **Test 26 – Clear EEPROM**

- When the Start pad is pressed the SSD will display “EE”.
- Next, pressing and holding the Start pad for 3 seconds will clear all EEPROM (including any fault codes), restore to default settings, and sound a valid tone and update the display to “- -”.

### **Tests 01, 02, 04, 06, 08, 21, 22 & 23 – Various Version Checks**

- When the Start pad is pressed, the SSD will display the major and then minor digit of the version number.
- The “Extra Heavy” Soil Level LED will be lit when the SSD is displaying the Major version digit.
- The “Heavy” Soil Level LED will be lit when the SSD is displaying the Minor version digit.

# Additional Diagnostics

## H2O Supply Message

An “H2O Supply” message scrolling on the display is NOT a fault code. It is a message indicating to the consumer that the control has not seen a frequency change from the pressure sensor. This can be caused by a few things that the consumer or installer can check and correct if no water is entering the washer.

- The water supply could be turned off.
- The hose or water valve screens could be clogged.
- The hoses could be pinched.

If water is entering the washer and the H2O message is displayed, check the following:

- Drain hose is not too far into the house standpipe. This will cause the water to be siphoned out of the tub.
- The pressure sensor hose may be blocked.
- Loose or disconnected wire harness connections or broken harness wire to the pressure sensor.
- Pressure sensor malfunctioning.

The H2O scrolling message can be cleared from the display ONLY after the drain pump has been allowed to run and shut off on its own. This takes approximately 3 minutes. After the pump has stopped, wait 10 seconds and then turn the cycle knob to a different position. The H2O message will be cleared from the display.

If the pump does not shut off on its own before turning the cycle knob, button press or unplugging the washer, the complete H2O will start over from the beginning running the drain pump.

# Fault Codes

Fault Code (Hex)	Name	Description	Repair Action
1	UI EEPROM	Board software not operating correctly	<ol style="list-style-type: none"> <li>1. Clear the error code using <b>Service Mode</b> test T25.</li> <li>2. Verify model ID # using <b>Service Mode</b> test T01. If correct, go to next step. If incorrect, set the correct Model ID #. Power cycle and verify Model ID #.</li> <li>3. Power cycle and check that error does not return.</li> <li>4. If error comes back, replace UI (User Interface PCB).</li> </ol>
5	Bulk Dispense Detergent and Fabric Softener	Not dispensing properly	<ol style="list-style-type: none"> <li>1. Enter <b>Service Mode</b>. Actuate bulk dispense valves to check water flow and dispense operation.</li> <li>2. If no detergent or softener flow, check for blocked or kinked bulk dispense hose.</li> <li>3. If no flow, check for frequency (Hz) change at IMC. If frequency changes, replace IMC.</li> <li>4. If no frequency change, replace appropriate bulk tank pressure sensor.</li> <li>5. If no water flow, check resistance of the water valve coil (1k ohms) at IMC connector.</li> <li>6. If no resistance (open), check wiring harness and appropriate water valve coil.</li> <li>7. If resistance checks OK, check for 120 VAC at IMC connector.</li> <li>8. If no voltage, replace IMC (Inverter Machine Control). If voltage, replace water valve.</li> <li>9. If still no water flow, replace UI board (User Interface PCB).</li> </ol>
6	Bulk Dispense Detergent and Fabric Softener	Not dispensing properly	<ol style="list-style-type: none"> <li>1. Follow same actions as in Fault Code 5.</li> </ol>



Fault Code (Hex)	Name	Description	Repair Action
7	Stuck Button	Buttons not operating when pressed	<ol style="list-style-type: none"> <li>1. Check buttons and adjust.</li> <li>2. Loosen screws on backsplash and or UI board (User Interface PCB).</li> <li>3. Replace backsplash.</li> <li>4. Replace UI (User Interface PCB).</li> </ol>
8	Pressure Sensor	Not filling as designed	<ol style="list-style-type: none"> <li>1. Check frequency (Hz) using multimeter. Validate the frequency matches table in mini manual.</li> <li>2. If frequency is not correct, check wiring harness and pressure sensor.</li> <li>3. If frequency is correct, but error persists, replace IMC (Inverter Machine Control).</li> </ol>
9	Lid Lock	Will not lock or unlock or is locked while lid is opened	<ol style="list-style-type: none"> <li>1. Check lid switch continuity at IMC.</li> <li>2. Check continuity of lid lock position. Opened or Closed?</li> <li>3. Check operation of lid lock. Plunger should slide freely in and out.</li> <li>4. Check lid lock wiring harness from IMC to lock assembly.</li> <li>5. If lid lock OK, replace IMC (Inverter Machine Control). If error persists, replace User Interface PCB.</li> </ol>
A	No Fill	Unit not filling with water properly	<ol style="list-style-type: none"> <li>1. Confirm house water supply is on and has proper water pressure.</li> <li>2. Check for kinked hoses.</li> <li>3. Check hose screens. Make sure they are not clogged.</li> <li>4. Check the lid switch continuity. The washer will not fill with the lid switch open.</li> <li>5. Check pressure sensor and pressure sensor hose.</li> </ol>

Fault Code (Hex)	Name	Description	Repair Action
			<ol style="list-style-type: none"> <li>6. Check resistance of the water valve coil (1k ohms).</li> <li>7. Check for 120 VAC to the water valve.</li> <li>8. If proper voltage and resistance, replace water valve assembly.</li> </ol>
B	Drain Pump	Water remaining in basket	<ol style="list-style-type: none"> <li>1. Check installation instructions for proper standpipe height.</li> <li>2. Check pressure sensor frequency (Hz) and pressure sensor hose.</li> <li>3. Check resistance of the pump (16.5 ohms) from the UI (User Interface PCB).</li> <li>4. If open circuit, check wiring harness to the pump and pump motor.</li> <li>5. Check for 120 VAC to the drain pump.</li> <li>6. If voltage is present and pump does not operate, replace pump.</li> <li>7. If voltage is not present, replace IMC (Inverter Machine Control).</li> </ol>
D	IMC (Inverter Machine Control) Communication Time-out	No operation	<ol style="list-style-type: none"> <li>1. Reset control boards by unplugging the washer for 30 seconds.</li> <li>2. Check wiring harness connections between the IMC and UI boards.</li> <li>3. If still no operation, replace IMC (Inverter Machine Control).</li> </ol>
E	Lid Lock	Will not lock or unlock or is locked while lid is opened	<ol style="list-style-type: none"> <li>1. Check lid switch continuity at IMC.</li> <li>2. Check continuity of lid lock position. Opened or Closed?</li> <li>3. Check operation of lid lock. Plunger should slide freely in and out.</li> <li>4. Check lid lock wiring harness from IMC (Inverter Machine Control) to lock assembly.</li> </ol>

Fault Code (Hex)	Name	Description	Repair Action
			5. If lid lock OK, replace IMC (Inverter Machine Control). If error persists, replace User Interface PCB
F	Heater Water Level	Check for water in tub by continuity between heater and thermistor	<ol style="list-style-type: none"> <li>1. With water in tub, check continuity between the heater sheath and the thermistor case from IMC.</li> <li>2. If no continuity, check harness and connections at IMC, thermistor and heater.</li> <li>3. If continuity is present, replace IMC (Inverter Machine Control).</li> </ol>
10	Slow Fill	Not enough water	<ol style="list-style-type: none"> <li>1. Check house water supply and proper water pressure.</li> <li>2. Check for kinked hoses.</li> <li>3. Check hose and water valve screens. Make sure they are not clogged.</li> <li>4. Check the lid switch continuity. The washer will not fill with the lid switch open.</li> <li>5. Check resistance of the water valve coil (1k ohms).</li> <li>6. Check for 120 VAC to the water valve</li> <li>7. If proper voltage and resistance, replace water valve assembly.</li> <li>8. Check pressure sensor and pressure sensor hose.</li> </ol>
11	Heater	Not reaching target temperature	<ol style="list-style-type: none"> <li>1. Check resistance of heater (approximately 12 ohms).</li> <li>2. Check resistance of thermistor (approximately 12k ohms at 77F)</li> <li>3. Replace heater and/or thermistor if necessary.</li> <li>4. Energize the heater in <b>Service Mode</b> and check for 120 VAC/ 10amps.</li> </ol>

Fault Code (Hex)	Name	Description	Repair Action
			5. If no voltage, and wiring harness is OK, replace IMC (Inverter Machine Control).
12	IMC (Inverter Machine Control) Communication Time-out	No operation	<ol style="list-style-type: none"> <li>1. Reset control boards by unplugging the washer for 60 seconds.</li> <li>2. Check wiring harness connections between the IMC and UI boards.</li> <li>3. If still no operation, replace IMC (Inverter Machine Control).</li> </ol>
16	Mode Shifter	Mode shifter not engaged to spin	<ol style="list-style-type: none"> <li>1. Using an ohm meter, check to ensure mode shifter switch is in the open position.</li> <li>2. Check resistance of mode shifter motor (approximately 3.8k ohms).</li> <li>3. Check for 120 VAC to the mode shifter motor at the IMC.</li> <li>4. If voltage is not present while activating the mode shifter in the service mode, replace the IMC (Inverter Machine Control).</li> <li>5. Check mode shifter coupler for damage and ability to slide in and out freely.</li> <li>6. Replace mode shifter assembly if necessary.</li> </ol>
17	Mode Shifter	Mode shifter not engaged to agitate	<ol style="list-style-type: none"> <li>1. Using an ohm meter, check to ensure mode shifter switch is in the closed position.</li> <li>2. Check resistance of mode shifter motor (approximately 3.8k ohms).</li> <li>3. Check for 120 VAC to the mode shifter motor at the IMC.</li> <li>4. If voltage is not present while activating the mode shifter in the service mode, replace the IMC (Inverter Machine Control).</li> </ol>

Fault Code (Hex)	Name	Description	Repair Action
			<ol style="list-style-type: none"> <li>5. Check mode shifter coupler for damage and ability to slide in and out freely.</li> <li>6. Replace mode shifter assembly if necessary.</li> </ol>
18	Mode Shifter	Mode shifter taking too long to engage	<ol style="list-style-type: none"> <li>1. Using an ohm meter, check to ensure mode shifter switch is in the open or closed position.</li> <li>2. Check resistance of mode shifter motor (approximately 3.8k ohms).</li> <li>3. Check for 120 VAC to the mode shifter motor at the IMC.</li> <li>4. If voltage is not present while activating the mode shifter in the service mode, replace the IMC (Inverter Machine Control).</li> <li>5. Check mode shifter coupler for damage and ability to slide in and out freely.</li> <li>6. Replace mode shifter assembly if necessary.</li> </ol>
19	Flood Protection	Flood level detected	<ol style="list-style-type: none"> <li>1. Check water valve is not filling washer tub in the off position.</li> <li>2. If water valve is leaking, replace water valve assembly.</li> <li>3. Check pressure sensor frequency (Hz). Validate the frequency matches table in mini manual.</li> <li>4. If frequency is not correct, check wiring harness, pressure sensor and pressure sensor hose.</li> <li>5. If frequency is correct, but error persists, replace IMC (Inverter Machine Control).</li> </ol>
65	Lid Lock	Will not lock or unlock or is locked while lid is opened	<ol style="list-style-type: none"> <li>1. Check lid switch continuity at IMC.</li> <li>2. Check continuity of lid lock position. Opened or Closed?</li> </ol>

Fault Code (Hex)	Name	Description	Repair Action
			<ol style="list-style-type: none"> <li>3. Check operation of lid lock. Plunger should slide freely in and out.</li> <li>4. Check lid lock wiring harness from IMC (Inverter Machine Control) to lock assembly.</li> <li>5. If lid lock OK, replace IMC (Inverter Machine Control). If error persists, replace User Interface PCB.</li> </ol>
66	Lid Lock	Will not lock or unlock or is locked while lid is opened	<ol style="list-style-type: none"> <li>1. Check lid switch continuity at IMC.</li> <li>2. Check continuity of lid lock position. Opened or Closed?</li> <li>3. Check operation of lid lock. Plunger should slide freely in and out.</li> <li>4. Check lid lock wiring harness from IMC (Inverter Machine Control) to lock assembly.</li> <li>5. If lid lock OK, replace IMC (Inverter Machine Control). If error persists, replace User Interface PCB.</li> </ol>
68	Pressure Sensor Error	Pressure sensor out of range	<ol style="list-style-type: none"> <li>1. Check frequency (Hz) using multimeter. Validate the frequency matches table in mini manual.</li> <li>2. If frequency is not correct, check wiring harness and pressure sensor.</li> <li>3. If frequency is correct, but error persists, replace IMC (Inverter Machine Control).</li> </ol>
6A, 6B	Thermistor Error	Thermistor open or short	<ol style="list-style-type: none"> <li>1. Check thermistor resistance. Validate the resistance matches the table in mini manual.</li> <li>2. Check wiring harness and connections.</li> <li>3. Replace thermistor.</li> </ol>

Fault Code (Hex)	Name	Description	Repair Action
72	Inverter Spin Redundancy	IMC detected spin speeds with either lid unlocked or open	<ol style="list-style-type: none"> <li>1. Attempt to operate a Drain and Spin cycle.</li> <li>2. If error clears itself and unit operates normally, then there is no issue.</li> <li>3. If error persists replace IMC (Inverter Machine Control).</li> </ol>
75	Lid Lock	Will not lock or unlock or is locked while lid is opened	<ol style="list-style-type: none"> <li>1. Check lid switch continuity at IMC.</li> <li>2. Check continuity of lid lock position. Opened or Closed?</li> <li>3. Check operation of lid lock. Plunger should slide freely in and out.</li> <li>4. Check lid lock wiring harness from IMC (Inverter Machine Control) to lock assembly.</li> <li>5. If lid lock OK, replace IMC (Inverter Machine Control). If error persists, replace User Interface PCB.</li> </ol>
76	Detergent Bulk Dispenser Sensor	Sensor not reading correctly	<ol style="list-style-type: none"> <li>1. Check frequency (Hz) using multimeter. Validate frequency matches table in the mini manual.</li> <li>2. If frequency is correct, replace IMC (Inverter Machine Control).</li> <li>3. If frequency is incorrect, check harness and connectors. If good, replace the bulk tank sensor.</li> </ol>
77	Softener Bulk Dispenser Sensor	Sensor not reading correctly	<ol style="list-style-type: none"> <li>1. Check frequency (Hz) using multimeter. Validate frequency matches table in the mini manual.</li> <li>2. If frequency is correct, replace IMC (Inverter Machine Control).</li> <li>3. If frequency is incorrect, check harness and connectors. If good, replace the bulk tank sensor.</li> </ol>

Fault Code (Hex)	Name	Description	Repair Action
C9, CA, CC, CD, CE, CF, D5, DD, DE, DF	IMC (Inverter Machine Control) Fault	IMC (Inverter Machine Control) Fault	<ol style="list-style-type: none"> <li>1. Reset IMC by unplugging washer from 60 seconds. Attempt to operate a Drain and Spin cycle.</li> <li>2. Enter <b>Service Mode</b> and check that error has cleared.</li> <li>3. If error persists, or unit does not spin, replace IMC (Inverter Machine Control).</li> </ol>
CB	DC Bus Brownout	DC bus voltage too low	<ol style="list-style-type: none"> <li>1. Check AC line voltage is correct.</li> <li>2. Reset IMC by unplugging washer from 60 seconds. Attempt to operate a Drain and Spin cycle.</li> <li>3. Enter <b>Service Mode</b> and check that error has cleared.</li> <li>4. If error persists, or unit does not spin, replace IMC (Inverter Machine Control).</li> </ol>
CB	DC Bus High	DC bus voltage too high	<ol style="list-style-type: none"> <li>1. Check AC line voltage is correct.</li> <li>2. Reset IMC by unplugging washer from 60 seconds. Attempt to operate a Drain and Spin cycle.</li> <li>3. Enter <b>Service Mode</b> and check that error has cleared.</li> <li>4. If error persists, or unit does not spin, replace IMC (Inverter Machine Control).</li> </ol>
CC	Motor Temp high	Motor Temp high	<ol style="list-style-type: none"> <li>1. Visually check that the motor has no signs of overheating.</li> <li>2. Reset IMC by unplugging washer from 60 seconds. Attempt to operate a Drain and Spin cycle.</li> <li>3. Enter <b>Service Mode</b> and check that error has cleared.</li> <li>4. If error persists, or unit does not spin, replace IMC (Inverter Machine Control).</li> </ol>



Fault Code (Hex)	Name	Description	Repair Action
D2	Locked Rotor	Locked rotor	<ol style="list-style-type: none"> <li>1. Check the motor and basket is free to spin.</li> <li>2. Reset IMC by unplugging washer from 60 seconds. Attempt to operate a Drain and Spin cycle.</li> <li>3. Enter <b>Service Mode</b> and check that error has cleared.</li> <li>4. Check harness and motor connections.</li> <li>5. If error persists, or unit does not spin, replace IMC (Inverter Machine Control).</li> </ol>
D3	Hall Sensor Fault	Issue with pulses from hall sensor	<ol style="list-style-type: none"> <li>1. Reset IMC by unplugging washer from 60 seconds. Attempt to operate a Drain and Spin cycle.</li> <li>2. Enter <b>Service Mode</b> and check that error has cleared.</li> <li>3. If error persists or unit does not spin, check hall sensor harness and module.</li> <li>4. If hall sensor and harness check OK, replace IMC (Inverter Machine Control).</li> </ol>

# Explaining 0D and D3 Fault Codes

Upon power-up (at install or coming back from a power loss), each electronic control board UI (User Interface), MC (Machine Control), and INV (Inverter) perform a self-diagnostic test (SD). If a SD fails, the MC and/or INV will not talk to the UI. When the UI doesn't get communication from the MC or the INV, or fails its own SD, The UI (at power up only) will display no other LED's except for the bottom most LED in each column under Soil, Temp, or Spin selection range.

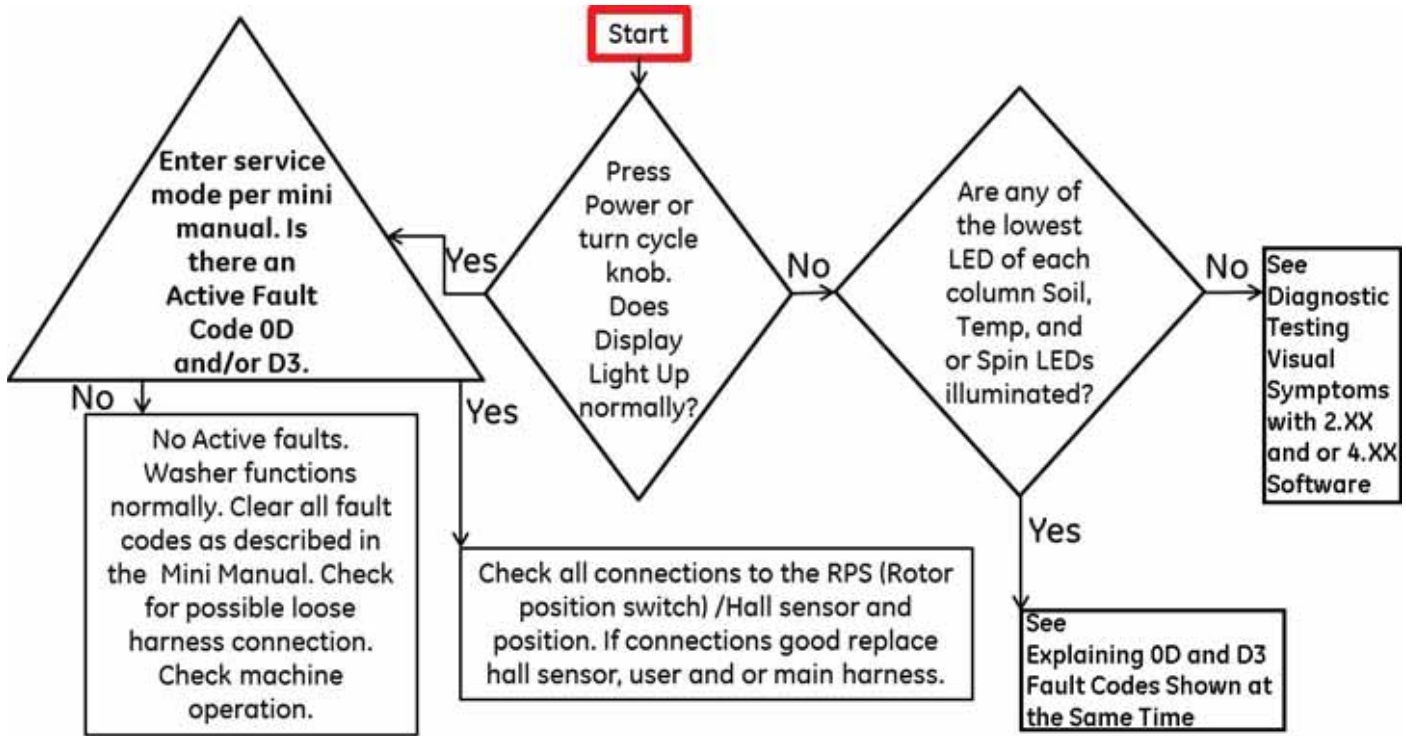

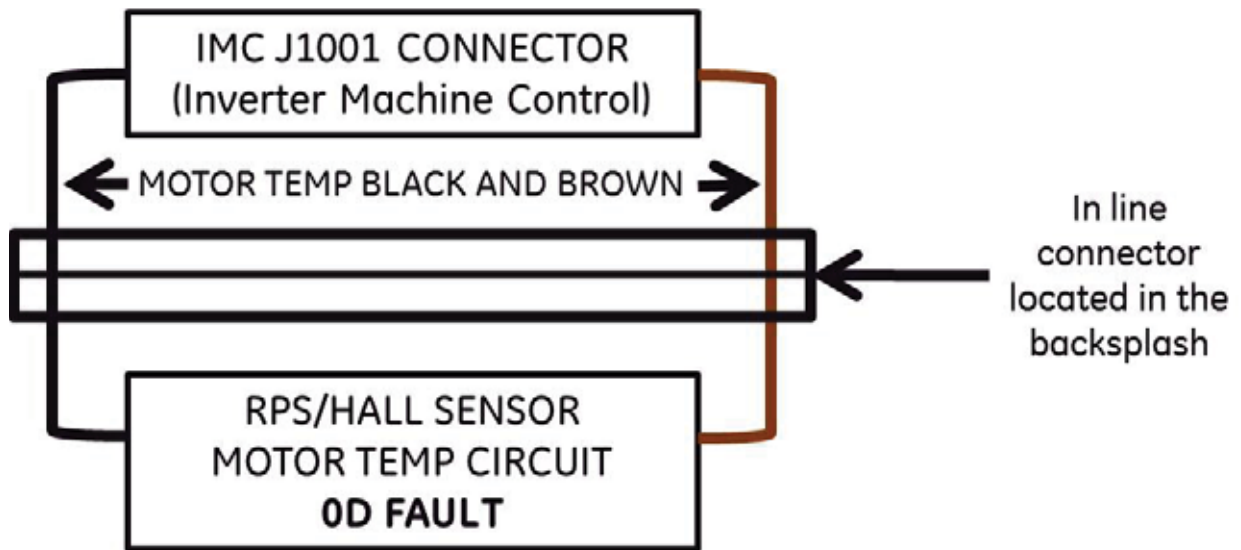

If the Motor Temp Communication Circuit wire or the RPS is open, “0D Fault” will be displayed in the Service Mode. Replace the RPS/Hall Sensor. If the fault remains, check the harness continuity from the IMC (J1001 connector) to the RPS/Hall Sensor. If open, replace user interface harness and/or the main harness. This should read approximately 8k ohm + 1k ohm at room temperature.

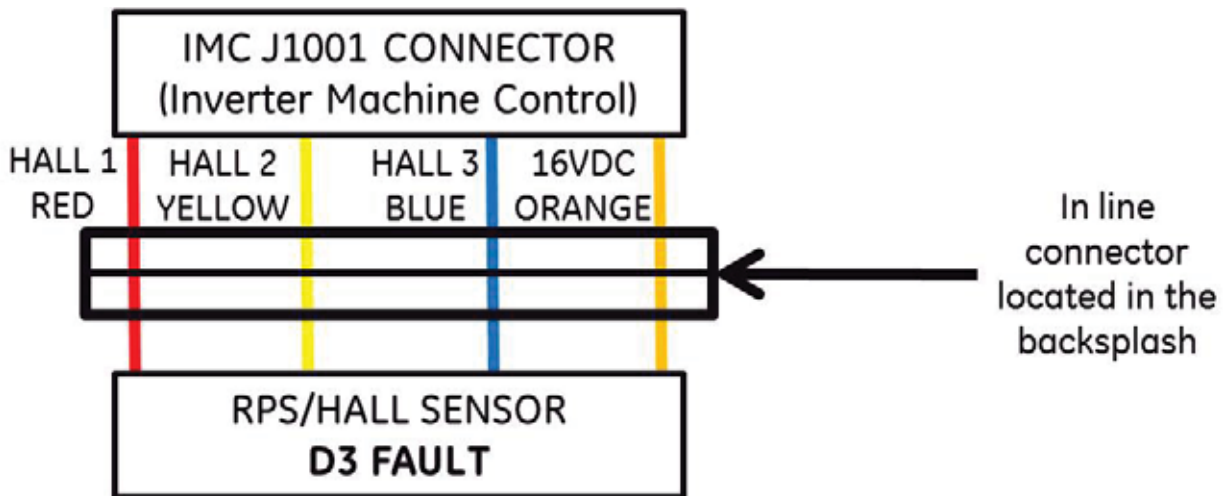

If the RPS/Hall Sensor or any one of the four circuit wires are open, a D3 fault will be displayed in the Service Mode. Replace the RPS/Hall Sensor. If the fault remains, check the harness continuity from the IMC (J1001 connector) to the RPS/Hall Sensor. If open, replace user interface harness and or main harness.

## Explaining 0D and D3 Fault Codes Shown at the Same Time

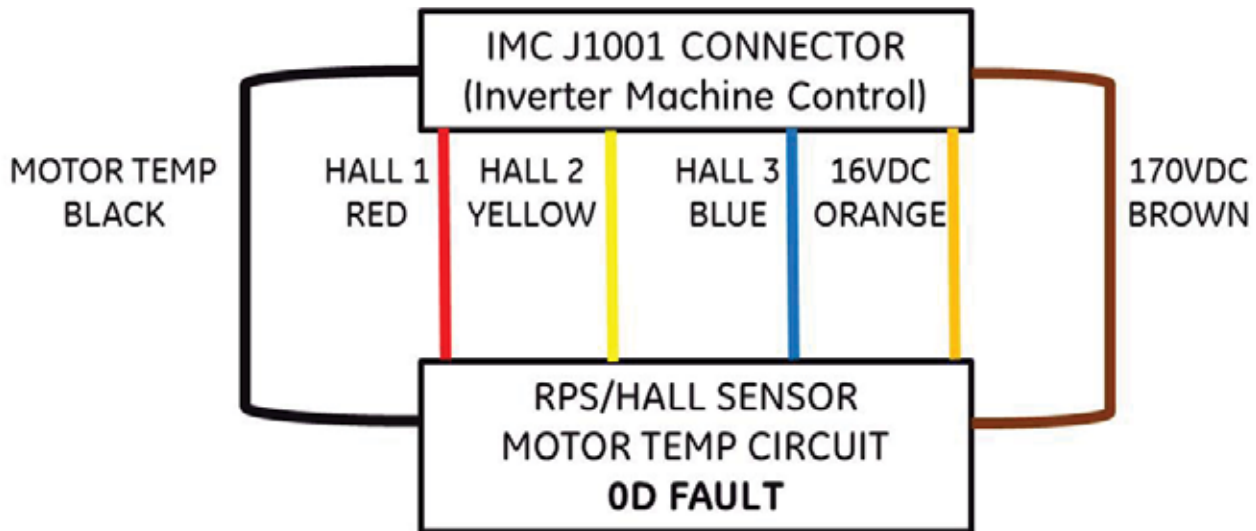

If both 0D and D3 fault codes are showing active at the same time, check the harness connectors at the IMC (J1001 connector) and also at the RPS/HALL sensor. The connector at the sensor might look like it is connected but may not be. Disconnect it from the sensor and reconnect until it clicks locking it in place.

If the lowest LED for SPIN stays ON (in this example: No Spin), the Inverter (INV) isn't communicating with the UI. 0D and/or D3 fault codes will show when in Service Mode. Check the harness connection between UI and IMC. Also, check the **black** and **brown** wires going down to the RPS/Hall Sensor. (Motor Temp Communication Circuit)

If the lowest LEDs for both Temp and Spin (in this example: Tap Cold and No Spin) both come on, there is an open GEA bus (Communication) connection (**purple** wire) between the MC J603 and UI.



If the lowest LED for Temp (in this example - Tap Cold) stays ON, the Machine Control (MC) isn't communicating with the UI. Check the harness from the INV to the UI. If good, replace the INV.

If the lowest LED of the Soil (in this example: Extra Light) stays ON, the User Interface (UI) has an internal issue. Replace the UI.



# Diagnostic Testing Visual Symptoms with 2.XX and or 4.XX Software

## **Open wires from the INV/MC to the UI**

### **Purple wire INV/MC to UI – GEA bus (communication between boards)**

- Disconnected or cut wire – Lowest Temp and Spin LEDs on – No other LEDs on
- No basket movement
- No UI operation
- If disconnected mid cycle, will light the Lowest Temp and Spin LEDs again after approximately 15 seconds

### **Yellow wire IMC/MC to UI - Ground**

- Disconnected or cut wire – No UI operation
- No basket movement

### **Brown wire INV/MC to UI – Supplies 7.5 VDC to the UI**

- Disconnected or cut wire – No lights on the display
- LED on the inverter board flashes 3 times, then pauses

### **Red Wire INV/MC to UI - Supplies 12 VDC to the UI**

- Disconnected or cut wire – Normal lights and display
- Normal flash on the INV – 1 sec on, 1 sec off
- Washer will operate normally
- No tones for any button presses
- Will not let NewFi connect

Boards will automatically reset when repaired or reconnected and will operate normally.

## **Open wires from the INV/MC to the RPS/Hall Sensor**

### **Black and Brown wire to the Hall Sensor – Motor Temp - 0D Fault**

- Disconnected or cut wire – Normal UI operation but will not start cycle
- Not basket movement
- No pump
- If powered up after unplugging the washer, No Spin LED on, No other UI operation
- Orange wire to the Hall sensor – 16.2VDC to the Hall Sensor – D3 Fault
- Disconnected/cut wire from the UI or RPS/Hall Sensor– Normal UI operation
- LED on the inverter board flashes 3 times then pause
- Cycle Prep in the display then timer counts down
- No basket movement

### **Blue, Red and Yellow wires to Hall Sensor – Same as orange**

#### **Hall Sensor Disconnected – OD and D3 Fault**

- Disconnected or cut wire from the UI – Normal UI operation
- No basket movement
- Cycle Prep in the display then time counts down while filling. Display will go to SENSE when it tries to mode shift and Pause when timed out. Depending on when where the mode shifters position is, it may not count down and go right into Sense. This also happen if the RPS/Hall Sensor is out of position.
- If unplugged and then plugged back in No Spin LED will be lit
- No other UI operation

#### **Pressure Switch Connection**

- Disconnected or cut wire from the pressure switch
- Pump will turn on
- UI will operate normally but will not start a cycle

Boards will automatically reset when repaired or reconnected and will operate normally.

# “SEnSE” is Scrolling in the Display/No Display

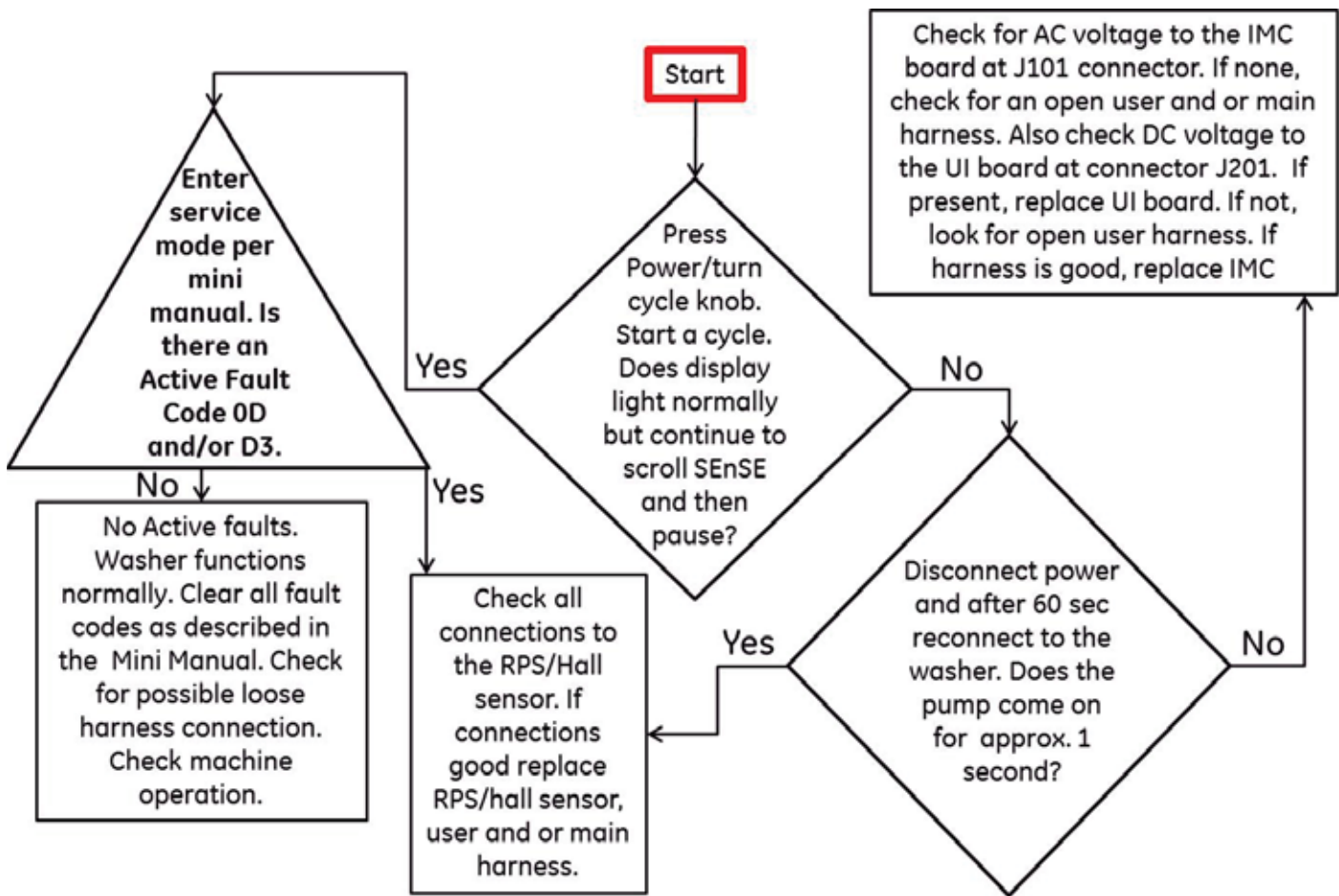



# Cabinet and Structure

## Backsplash

The backsplash is a separate part of the washer that houses the button fingers that press against the buttons on the User Interface (UI) board. The UI and the Inverter Machine Control (IMC) mounts to the backsplash.

The backsplash needs to be removed from the cabinet in order to access components including the control board, water valve, and pressure sensor.

### Backsplash Removal

1. Open the lid to an approximate 45° angle.
2. Using a screwdriver, push in on the front clips that hold the backsplash front to the top cover. Pull slightly forward and lift the backsplash front up at the same time to release it from the front clips.

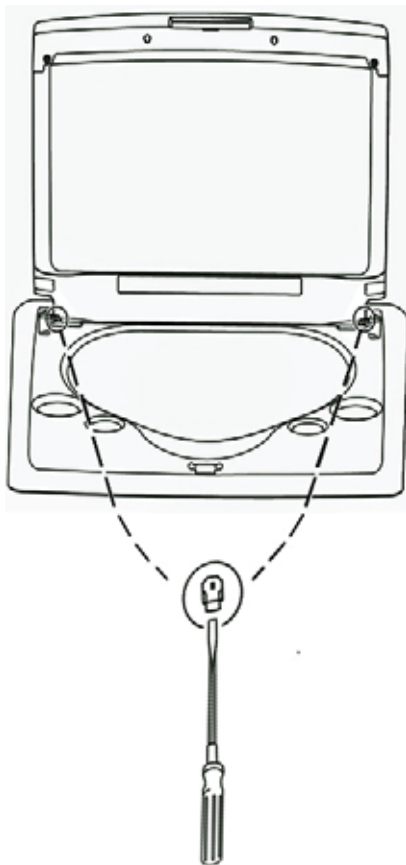

3. Close the lid and lay a towel over the washer to protect the product. Lift up slightly to clear the front clips and push back to disengage the rear cover from the two retention clips.

**NOTE:** The following picture illustrates the clip inside the backsplash.



4. Rotate the backsplash towards the front of the washer, and lay it face down on top of the washer.
5. Remove the four screws from the rear cover and separate the backsplash assembly.

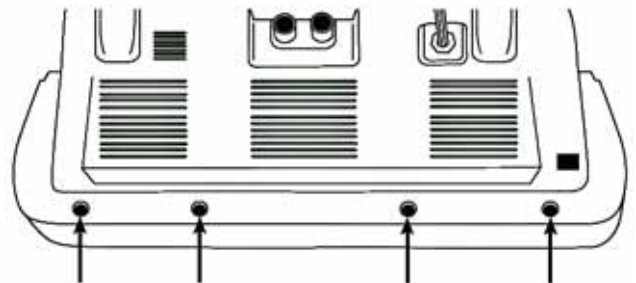

**NOTE:** Handle the harness that goes to the RJ45 board carefully when separating the backsplash.



## Backsplash Reassembly

1. Reconnect all of the wire connections to the control board.
2. Reconnect the harness to the RJ45 board on the rear half of the backplash.
3. Refasten the rear half of the backplash to the front half with the 1/4 in. hex screw.
4. Reinstall the backplash to the top cover, sliding the rear of the backplash into the clips on the top cover first. Pull the backplash towards the front of the top cover, lifting slightly to go over the front clips, one on each side. **NOTE:** With the two bottom rear backplash screws gone, the front of the backplash will flex open when attaching to the front retaining clips.
5. Push down on the front of the backplash until the front clips snap into position.

**NOTE:** Be careful not to pinch the harness when reinstalling the backplash assembly.

# UI Logic Board

The User Interface (UI) board is accessible once the six dual head screws on the back cover of the Backsplash have been removed.

## UI Logic Board Removal

To access the board assembly, the backslash will need to be removed and then opened (See **Backsplash Removal** for instructions).

1. Disconnect all of the wire connectors to the inverter board assembly.
2. Use needle nose pliers to remove all of the clips from the heat sink on the inverter board by placing the pliers under the clip, then pushing the handle of the pliers towards the heat sink. This will allow the clip to release from the heat sink.



3. Remove the eight 1/4 in. hex head screws that secure the Inverter Machine Control (IMC) board assembly to the backslash.

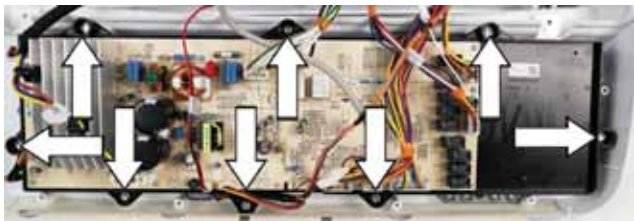

4. Transfer the Cycle Status Lights display to the new control board assembly. Use a razor safety knife and carefully separate the glue securing the Cycle Status Lights display to the UI board.

**Note:** It does not have to be re-glued back to the UI board.

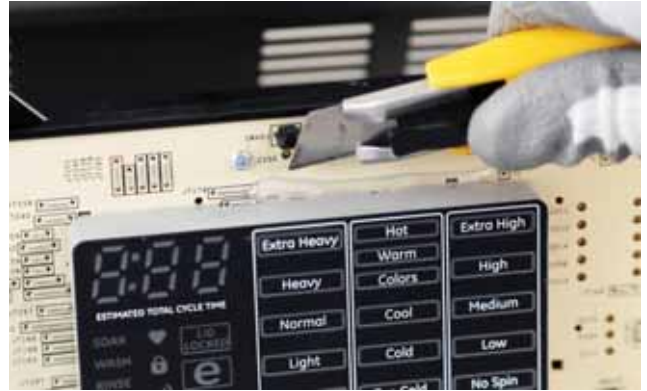

5. Carefully pull the Cycle Status Lights display away from the UI board.



6. Lift up on the board assemblies' plastic housing to unclip the mounting clips, then flip the board assembly over to access the UI board. Replace the old UI Logic Board with the new UI Logic Board.



## Reinstalling the Board Assembly

1. Snap the clips on the plastic housing onto the backslash.
2. Secure the plastic housing with the boards attached to the backslash using the eight 1/4 in. hex head screws.
3. Reconnect all of the harness connectors to the board assembly.

## UI Logic Board Diagnostics

### UI Logic Board Voltage

1. Check from the J603 connector on the inverter board.
2. Look for approximately 12 VDC from the **red** wire (pin 4) to the **yellow** wire (pin 1). There should also be approximately 7.5 VDC from the **brown** wire (pin 3) to the **yellow** wire (pin 1).
3. If either of these voltages are not present, replace the inverter board.
4. If the voltages are present and correct, check for voltage at the user interface (UI) board. If voltage is present there and the UI board does not power on, replace the UI board.

### UI Logic Board Strip Circuit

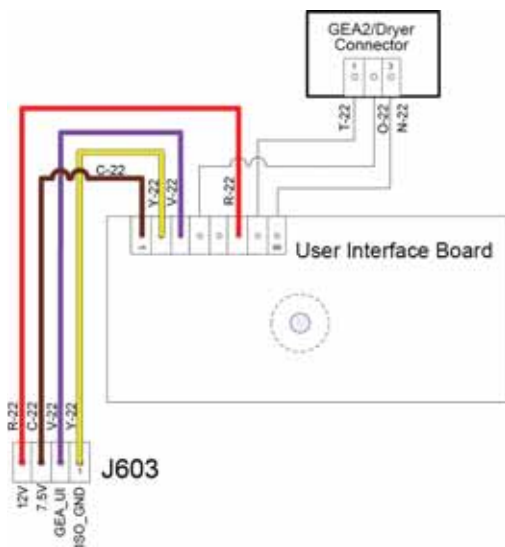

## Inverter Machine Control (IMC) Board

The Inverter Machine Control (IMC) board is accessible in the same manner as the UI Logic board, once the six dual head screws on the back cover of the Backsplash have been removed.

### Inverter Machine Control (IMC) Board Removal

To access the IMC board, the backsplash will need to be removed and then opened (See **Backsplash Removal** for instructions).

1. Disconnect all of the wire connectors to the inverter board assembly.
2. Use needle nose pliers to remove all of the clips from the heat sync on the inverter board by placing the pliers under the clip, then pushing the handle of the pliers towards the heat sync. This will allow the clip to release from the heat sync.



3. Remove the eight 1/4 in. hex head screws that secure the Inverter Machine Control (IMC) board assembly to the backsplash.

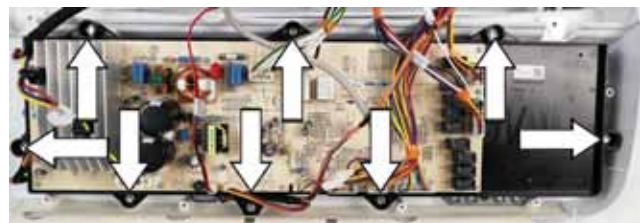

4. Transfer the Cycle Status Lights display to the new control board assembly. Use a razor safety knife and carefully separate the glue securing the Cycle Status Lights display to the UI board.

**Note: It does not have to be re-glued back to the UI board.**



- Carefully pull the Cycle Status Lights display away from the UI board.



- Lift up on the board assemblies' plastic housing to unclip the mounting clips.



### Inverter Machine Control (IMC) Assembly

- Snap the clips on the plastic housing onto the back splash.
- Secure the plastic housing with the boards attached to the back splash using the eight 1/4 in. hex head screws.
- Reconnect all of the harness connectors to the board assembly.

### Main Control Service LED

- The Main Control Service LED is located, looking at the board from the front of the washer, at the upper left of the IMC/Inverter Board, alongside the heat sink. The normal status of the LED should be a steady one second on, one second off. If the LED is not lit at all, check the voltage to the inverter board.



- If voltage is present, and the LED still does not flash, this indicates that the IMC/Inverter Board will need to be replaced. If the LED is flashing 3 flashes and then pauses, the inverter board has an error. Try resetting the board.
- The board can be reset by unplugging the power cord from the wall for at least 60 seconds, and then plugging the power cord back in to the wall.
- If the error persists, put the control into **Service Mode** and check for error codes. If no error codes are present, if the **Service Mode** is unresponsive, or if the UI board does not light up, check for DC voltage going to the UI board. If there is no voltage going to the UI board, and the boards do not light up, replace the Inverter Board.

### Inverter Machine Control (IMC) Board Diagnostics

- First check the house outlet for the proper voltage.
- Check for 120 VAC to the J101 connector **black** to **white** wires from the **LINE FILTER**.
- If no voltage is present, check line voltage coming into the line filter from the power cord connector. If there is no voltage coming out of the line filter to the IMC, replace the line filter.
- If no voltage, check the power cord connector and harness for damage.

## Inverter Machine Control (IMC) Board Strip Circuit

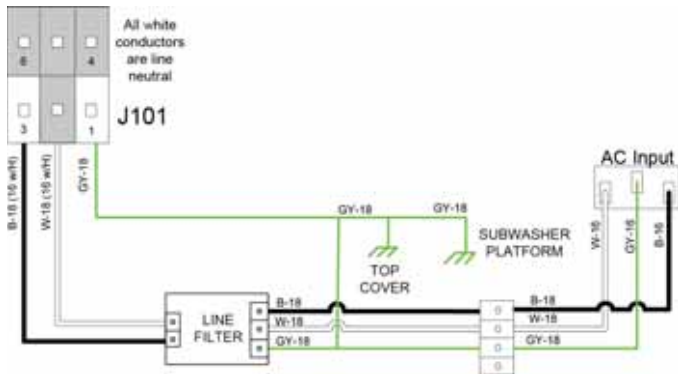

## Lid Assembly

The lid comes as a complete assembly. On all metal lids, the magnet can be ordered separately. On encapsulated glass lids, the glass and magnet comes as an assembled part.

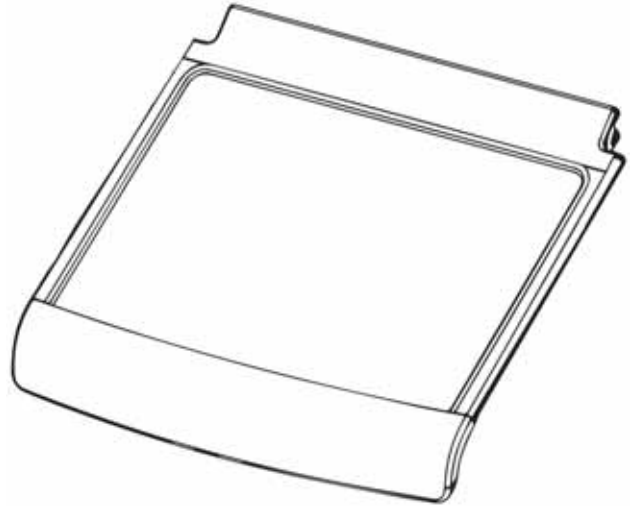

### Lid Assembly Removal

1. Open the lid.
2. Remove the four Phillips screws (two on each side).
3. Lift the lid up and off of the hinge.

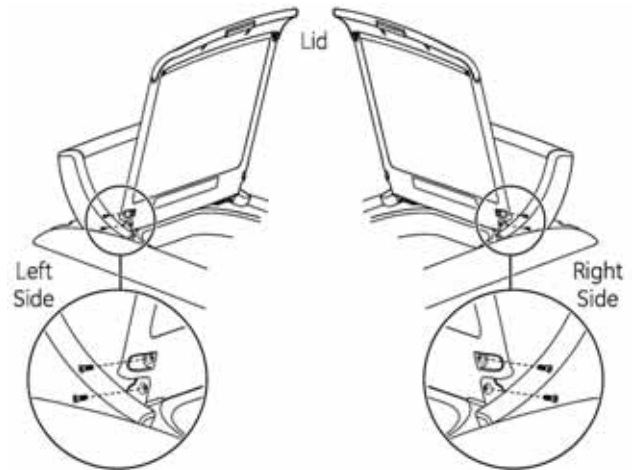

# Hinges

The glass encapsulated lids are slow closing so that the lid will not drop hard. The right and left hinges can be removed without raising the top cover.

## Hinge Removal

1. Remove the backsplash assembly and the lid assembly. (See **Backsplash Removal** and **Lid Assembly Removal** for instructions).
2. Reach hand under the top cover, grasping the hinge assembly while removing the two 1/4 in. hex head screws.

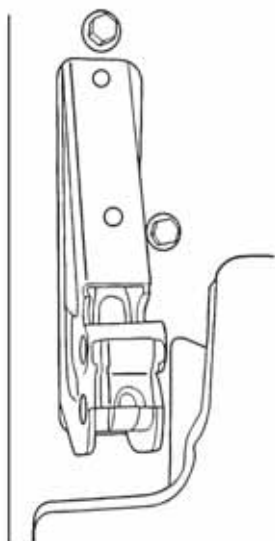

3. Slide the hinge out from under the top cover.

## Hinge Reinstallation

1. Insert the hinge from the underside of the top cover.
2. Reinstall the two 1/4 in. hex head screws that hold the hinge to the top cover.
3. Reinstall the lid and backsplash assembly.

# Top Cover

The top cover is used to house the dispenser cups, lid assembly, hinges, lid lock, lid switch, and the water supply tubes. The lid lock prevents the top cover from opening during operation, providing safety by restricting access to any moving parts.

## Top Cover Removal

1. Remove the Backsplash and Pressure Sensor assemblies. (See **Backsplash Removal** and **Pressure Sensor Removal** for instructions).
2. Remove the two white 1/4 in. screws at the rear of the cover that secure the cover to the rear rod support, as well as the ground screw connecting the wire to the top cover.



3. Use a putty knife to disengage the cover from the two clips mounted to the front flange of the apron. The front clips that hold the down the top cover to the apron are located approximately 7 inches in from the right and left sides of the washer. Once the cover is disengaged from the apron, lift up the front of the top cover from the front clips securing it to the washer.



4. Remove the hose clamps to disconnect the two bulk dispenser hoses where they connect to the fill funnel.



## NOTICE

If the unit being serviced is not a bulk dispenser washer, then Step 4 is unnecessary.

5. Remove the top cover.

**It is not necessary to remove the top cover to replace the water valve. See Water Valve Removal for further instructions.**



## Top Cover Reinstallation

1. At the front of the top cover, make sure to line the front clips on the wrapper and the slots on the top cover together. Once lined up, push down on the top cover to snap the clips into place.



2. If the clip and the slot in the top cover are not lined up, the top cover area where the slot is could be damaged or bent. This damage will result in the clip not locking into place correctly, as seen in the photograph below.



3. Reinstall the two white 1/4 in. hex head screws at the rear of the top cover that hold the top cover to the frame.
4. Reinstall the ground screw at the rear of the top cover.
5. Reinstall the Backsplash. (See **Backsplash Reinstallation** for instructions).

## Lid Lock

The lid lock is used to prevent injuries incurred from moving parts. Once the cycle starts, the lid lock is engaged, locking the lid. The lid lock assembly also contains the lid switch. The lid lock and the lid switch are one assembly. The lid switch needs to be operational for the lid lock to activate. The lid lock assembly consists of the lock motor, lock position switches and the lid switch.



### Lid Lock Assembly

In an unlocked state, the latch in the bezel will be in a retracted state, as shown below. When the lid is closed, the magnets in the lid assembly activate the lid switch, closing the switch.



When the switch circuit is closed, DC voltage is sent back to the inverter board. This prompts the lid lock motor to activate, resulting in the latch extending to a locked state, as seen in the photograph below.



## Lid Lock Removal

To remove the lid lock assembly, the backsplash needs to be removed, and the top cover needs to be raised. (See **Backsplash Removal** and **Top Cover Removal** for instructions).

### ⚠ CAUTION

When raising the top cover, be sure to tape the lid to the top cover to prevent it from opening.

1. Remove the two 1/4 in. hex head screws that mount the lock assembly to the bezel on the top cover.



2. Unclip the harness from the top cover and pull the rubber grommet through the top cover.



## Lid Lock Reassembly

1. Insert the grommet back through the hole in the top cover.
2. When looking at the top cover from the front, route the wire harness up through the underside of the top cover into the side clips.
3. Snap the wire harness into the clips located on the side of the dispenser cup.
4. Holding the bezel in place, and reinstall the lid lock assembly back into position using the two 1/4 in. hex head screws.
5. Reinstall the top cover back on to the cabinet.
6. Reinstall the backsplash assembly to the top cover.

### Lid Lock Motor Diagnostics

Check the resistance of the lid lock motor from the Inverter Board J407 connector **black** (pin 4) to **brown** (pin 5) wires. The resistance should read approximately 39 ohms.

**Lid Lock Motor:** The resistance should read approximately 39 ohms. It operates with DC voltage, at approximately 12 VDC.

**Lid Lock Position Locked/Unlocked:** The lid locked or unlocked signal voltage should be 5 VDC.

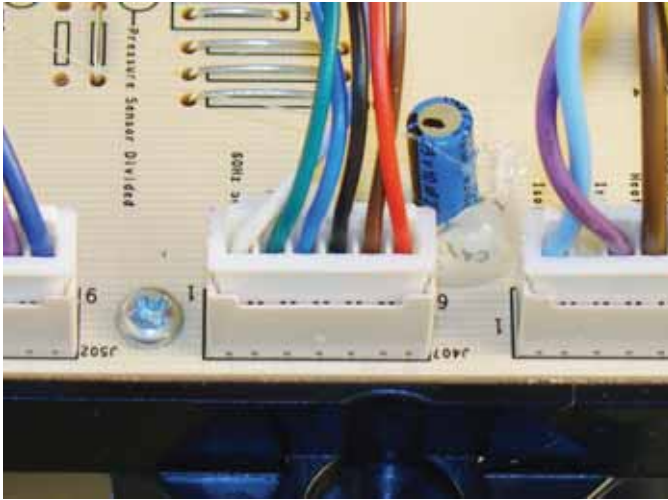

Check the lid lock position continuity from the J407 connector **blue** wire (position 3) to the **white** wires when unlocked. When the lid is locked, check the **red** wire (position 6) to the **white** wire (position 1).

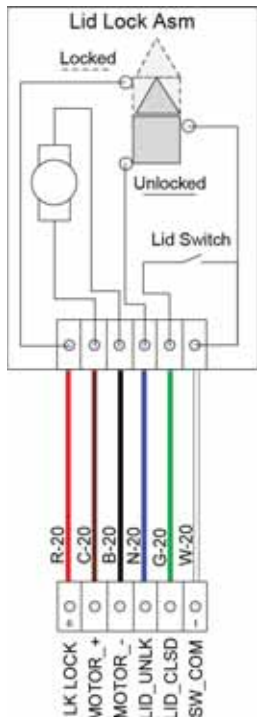

**Motor Circuit = 12VDC**  
Black - Brown = 39 Ω

**Lid Circuit = 5VDC**  
Lid Switch  
Green - White

**Lock Circuit = 5VDC**

Lid Locked  
Red - White

Lid Unlocked  
Blue - White

J407

The internal lid switch actuators in the lid lock assembly are closed by the magnets in the lid, shown by the two arrows at the bottom of the photograph below. The upper arrows in the photograph display the contacts of the lid lock assembly latch in an unlocked position.

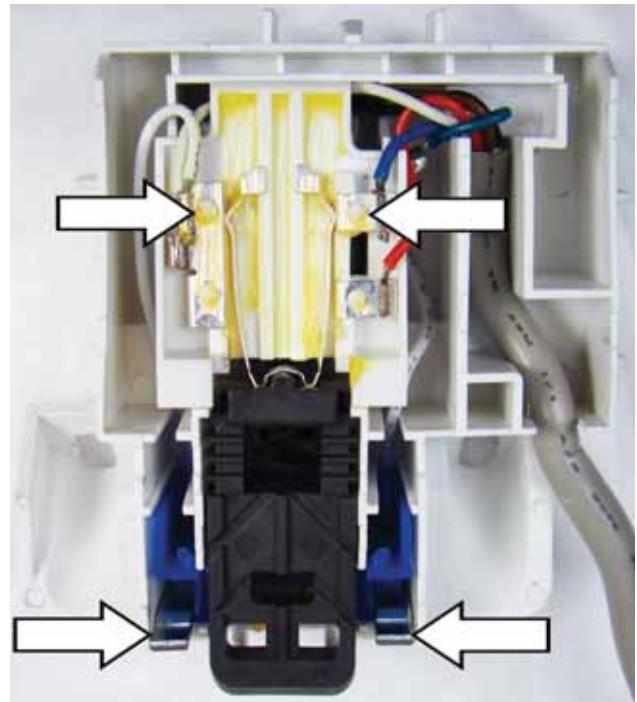

The photograph below displays the contacts of the lid lock assembly latch in a locked position.

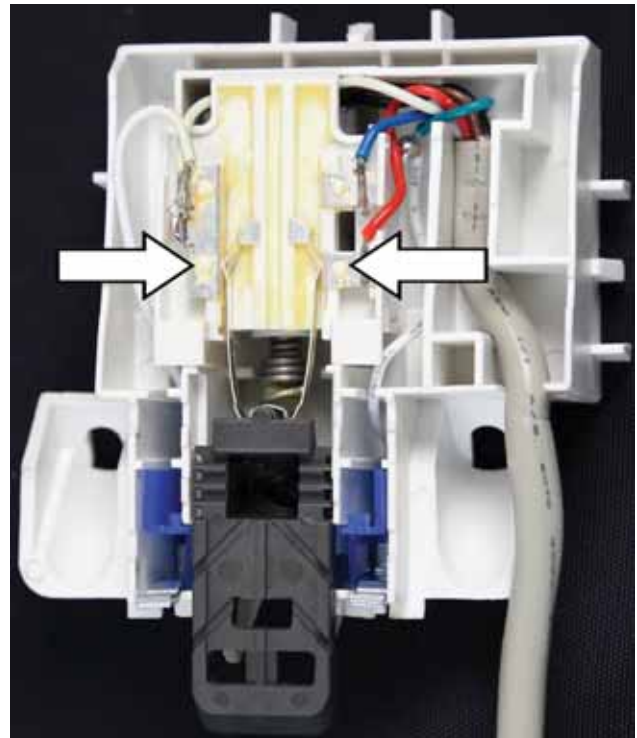

# LED Tub Light

The tub light is mounted to the fill funnel assembly. It receives approximately 3.8 VDC from the inverter board at the J204 connector.

## LED Tub Light Removal

1. Access to the inverter board is needed to disconnect the LED light harness from the inverter board. (See **Backsplash Removal** for instructions).
2. Disconnect the LED light from the J204 connector on the inverter board.

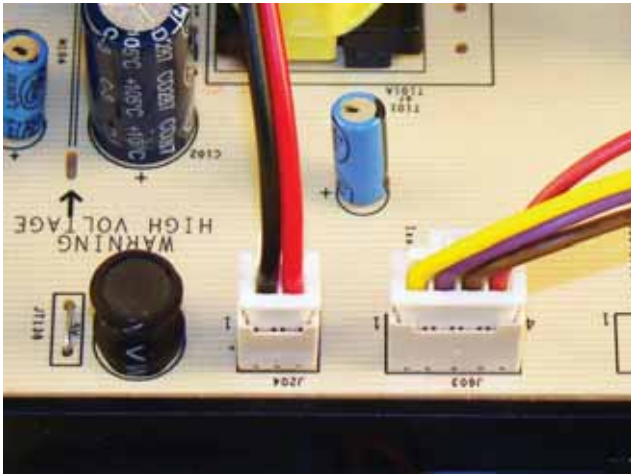

3. Use pliers to pull the grommet from the bracket of the fill funnel. Then push in on the two side clips of the LED tub light to release the light assembly from the fill funnel.



4. Pull the LED tub light, harness, and the grommet through the fill funnel.

## LED Tub Light Reassembly

1. Leading with the wires, route the LED tub light harness through the mounting bracket of the fill funnel and through the hole provided in the top cover.



2. Seat the rubber grommet into the hole in the fill funnel and top cover. The grommet will provide a moisture seal for that area.
3. Reconnect the harness connector to the inverter board.
4. Reinstall the backsplash assembly.

## LED Tub Light Diagnostics

Check from the J204 connector on the board.

Look for approximately 3.8 VDC.

If voltage is present, but no light, disconnect power from the washer.

Disconnect the J204 connector from the board.

Set the meter to the DIODE setting.

With your black lead on the **red** wire, and your red lead on the **black** wire, the meter should read approximately 0.727 if good.

If the meter leads are reversed to **red** on **red**, there should be no reading.

## LED Tub Light Strip Circuit

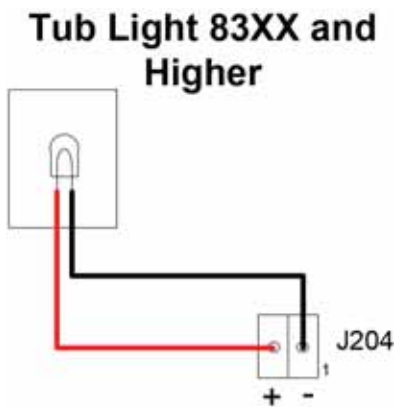

## Rear Panel

The rear panel provides access to the rear components that are mounted to the tub assembly. This also is the only access used to remove the basket and the tub assembly. The panel provides a stiffening support for the cabinet assembly when it is screwed to the cabinet.

### Rear Panel Removal

1. To remove the rear panel, pull the washer out far enough to access the twelve hex head screws securing the panel to the rear of the washer.

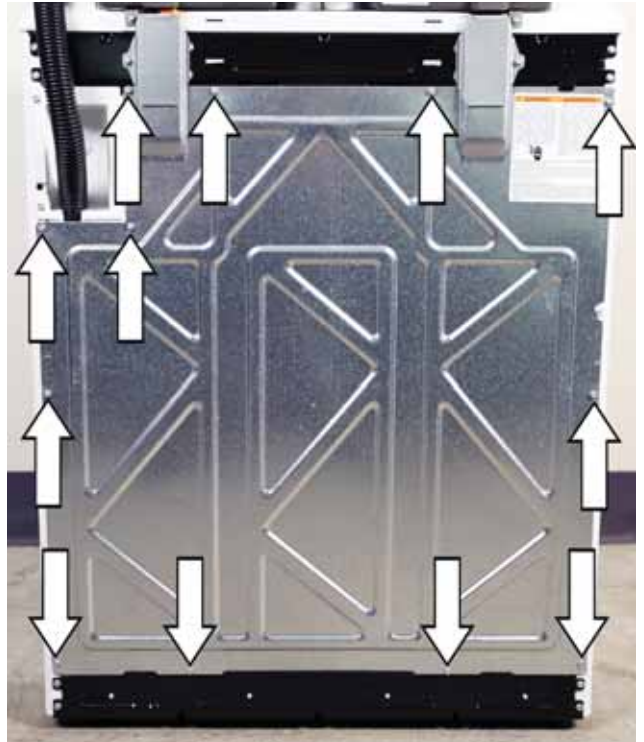

2. Remove the twelve 1/4 in. hex head screws and remove the rear panel from the rear upper suspension bracket and lower rear leveling leg brackets.

3. Once the back panel has been removed, the tub assembly and components become accessible.



#### Rear Panel Reinstallation

1. Fit the rear panel back into the rear upper suspension bracket and lower rear leveling leg brackets.
2. Reinstall the twelve 1/4 in. hex head screws.

## Leveling Legs

Keeping the washer level is critical because the clearance of the tub to the outer cabinet is minimal. It is normal for the tub to bump against the outer wrapper during usage, which the washer uses to sense when the load is out of balance.

#### Adjustment

Move the washer into its final position. Place a level on a flat top side edge of the washer. Adjust all four leveling legs by screwing them into or out of the foot brackets until the washer is level from left to right and front to back.

Should any of the leveling legs show signs of damage, order a new leg.



# Impeller Assembly

The impeller moves the clothes in the basket. It takes the place of the tall agitator. Impellers are designed to work best moving material around in the basket with low water levels.

## Impeller Removal

1. Remove the center cap from the impeller. Take a pocket screwdriver or putty knife and carefully pry the cap off.



2. Remove the 7/16 hex bolt that holds the impeller in place.



3. Lift the impeller up and off the shaft. The coupler may come off with the impeller.



## Impeller Reassembly

1. Reinstall the impeller and coupler onto the shaft spline. Install a new 7/16 hex bolt and torque to 60 inch pounds. **A new hex bolt is required because of the specific Loctite that is on the threads of the new bolts.**

### NOTICE

DO NOT REUSE THE OLD BOLT WITH REGULAR LOCTITE. USE A NEW BOLT.

# Suspension System

## Rod and Spring Suspension System

The rod and spring suspension system consists of assemblies which include: four rods each with a hook at the top, and four springs and spring covers that are each supported by a ball joint and ball socket that mount onto the support bracket. They are used to support the tub assembly and assist with balancing the load being washed. There are two rod and spring suspension systems mounted toward the rear of the washer and two toward the front. Each of the four assemblies are the same for the washer they are mounted on.

## Suspension System Removal

1. To remove the rod and spring assembly, the top cover assembly and components mounted to it will need to be removed. (See **Top Cover Removal** for instructions).
2. Once the top cover assembly is removed, disengage the suspension rod assembly from the tub by lifting up slightly on the tub assembly. Then slide the rod through the slot on the tub where the spring cover is seated.



3. Once the rod and spring are disengaged from the tub, lift the rod up to remove the upper ball joint from the rod.



4. To remove the ball joint from the rod, push on the lower end of the ball until it snaps off.

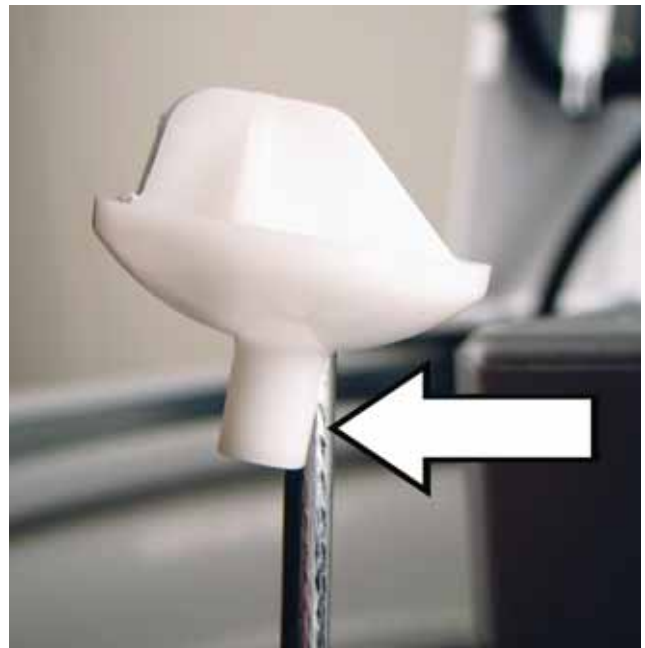



5. Slide the ball joint downward on the rod, until the hook is completely exposed.



6. Rotate the ball around until the hook is in the opposite direction.



7. The ball socket then needs to be removed by sliding it over and off the hook of the suspension rod.



8. To remove the socket cup, lift up on the rod support until the cover that is over the spring hits the bottom of the cup.



9. Pull upward with a firm pressure to pop the cup from the bracket. Then slip the ball socket off of the rod.



10. Slide the rod down through the support bracket and out of the machine.

### **Suspension System Reassembly**

1. Slide the new rod back up through the rod support.
2. The ball socket needs to slide over the hook of the rod, and be seated into the support bracket until it snaps into place.
3. Then install the support rod ball back onto the hook of the rod, and rotate the hook into position, snapping the ball into place.
4. Slide the rod into position through the cup.
5. Lift slightly on the tub, and push the rod assembly through the slot on the tub where the spring cover is seated to support the tub.
6. Reinstall the top cover assembly.

# Basket

The basket assembly consists of the stainless steel side wall and balance rings located at the top and bottom of the basket assembly. When ordered, this comes as a complete assembly.

## Basket Removal

1. The basket and tub assembly is serviced through the rear panel of the washer. The backsplash, lid and the top cover need to be removed to access the suspension brackets in the front and rear. (See **Backsplash Removal**, **Lid Assembly Removal**, **Rear Panel Removal**, and **Top Cover Removal** for instructions).
2. The drain hose will also need to be removed from the tub. Use a pan to catch the excess water in the drain hose.
3. Be sure that the harness that goes to the subassembly is moved to the sides of the apron so they are not damaged during the tub removal.
4. Remove the impeller. Once the impeller has been removed, remove the hub nut (1-5/16 reverse thread).
5. Roll the tub back and out of the washer apron and lay the tub on its side. Removing the tub assembly ergonomically prevents injuries.

## NOTICE

If using an impact gun to remove the hub nut, it is required to use the torque limiter to prevent damaging the threads on the shaft from going the wrong direction.



6. Remove the suspension brackets that hold the tub to the apron by removing the sixteen 1/4 in. hex screws, four on each corner.

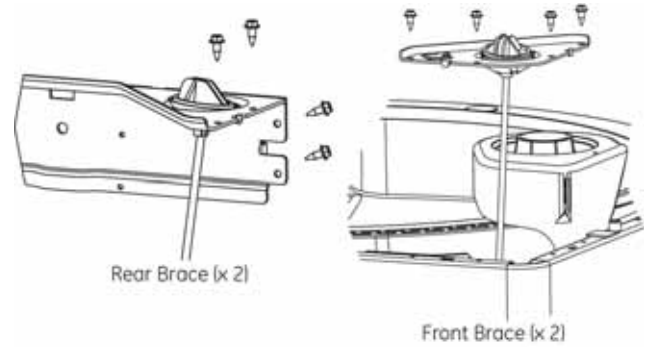

7. Lift the rear rod support off the apron. Remove the rod and spring assembly from the tub and set it on the floor.
8. Remove the front rod support brackets. Place the screw hole of the bracket on the post of the outer tub.



9. Roll the tub back and out of the washer apron and lay the tub on its side.

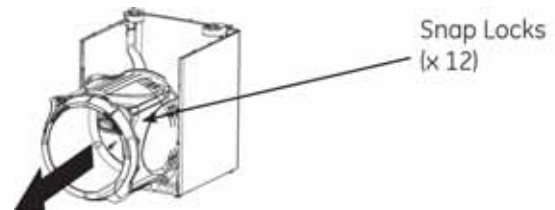

10. Remove the tub cover by lifting the twelve snap locks for the tub.
11. Slide the basket assembly out. Make sure that the flat washer under the basket remains on the shaft of the platform assembly.

## Basket Reinstallation

1. Reinstall the basket by sliding it back into the tub assembly, then roll back to the upright position.
2. Reinstall the tub cover by fastening the twelve clips on the cover to the tub.
3. Reinstall the front suspension support brackets to the front outer wrapper.
4. Reconnect the suspension rod and spring assembly back to the tub and lift onto the rear of the outer wrapper.
5. Fasten both the front and rear suspension brackets onto the outer wrapper with the sixteen 1/4 in. hex head screws.
6. Install the new hub nut onto the shaft of the platform assembly in the basket and tighten to 100 ft pounds.

### NOTICE

If using an impact gun to reinstall the hub nut, it is required to use the torque limiter to prevent damaging the threads on the shaft from over tightening.

7. Reinstall the harness, top cover, rear panel and the backsplash assembly.
8. Reinstall the impeller using a new bolt.

## Outer Tub

To access the outer tub, the rear panel must be removed (see **Rear Panel Removal** for instructions). The outer tub assembly is made of a plastic material that holds the water for the wash cycles. It is also used to mount components to it such as the drive motor, pumps, thermistor, heater, and platform shaft and tube assembly. The outer tub also has a built in overflow drain on it at the front of the tub assembly.

### Outer Tub Removal

1. Remove the basket assembly. (See **Basket Removal** for instructions).
2. Roll the complete tub assembly over to the upside down position. Remove all of the components, including the harnesses, from the bottom of the tub assembly.
3. Lift the outer tub off of the basket assembly.

### Outer Tub Reinstallation

1. Make sure the flat washer is on the bottom of the basket before setting the tub over and on the basket assembly.
2. Reinstall all of the components back onto the bottom of the tub assembly.
3. Continue by following the reinstallation of the basket assembly. (See **Basket Reinstallation** for instructions).

# Drive System

## Rotor

The rotor has magnets mounted within it that respond when voltage is applied to the stator. This creates a pulsating magnetic field (3 phase VDC), which then creates a strong magnetic force that repels the magnets on the rotor. This will cause the rotor to turn with the shaft in the platform assembly.

### Rotor Removal

1. To access the rotor or any component on the bottom of the washer, lean the washer back or lay on the washer on its side.

### NOTICE

If lying the washer on its side, and the model being repaired has a bulk dispense system on it, tape the vent holes on the top of the bulk tanks, and the oval opening on the fill funnel. See the NOTICE in the **Bulk Dispenser Tanks** section of this guide.

2. Remove the rotor by turning the 11/16 nut counter clockwise.



3. Remove the concave washer from the lower platform shaft. The washer should have a red color on one side.
4. Pull the rotor away from the washer.

### NOTICE

During removal and reassembly, be careful not to pinch any fingers between the rotor and the stator as the magnetic pull on the rotor is strong.

### Rotor Reassembly

1. To reinstall the rotor, slide it onto the shaft of the platform assembly, over the stator.
2. Install the concave washer onto the shaft. The side with the red color should go toward the rotor on the shaft.



3. Install the new 11/16 rotor nut onto the shaft of the platform assembly and tighten to 500 in. pounds.

# Stator

The stator receives three separate phases of pulsing VDC from the inverter board, which creates a magnetic force that causes the rotor to turn with the shaft.

## Stator Removal

1. Remove rotor. See **Rotor Removal** instructions.
2. Disconnect the harness from both the stator and the hall sensor.



3. Remove the three 1/2 in. hex bolts.



4. Remove and transfer the hall sensor from the stator that is being replaced to the new stator. (See **Hall Sensor Removal** for instructions).

## Stator Reassembly

1. To reinstall the stator, reconnect the three phase power wire connector.
2. Reinstall the three 1/2 in. hex bolts that mount the stator to the platform assembly, and torque to 130 inch pounds.
3. Reconnect the hall sensor wire. Make sure to seat the connector until it clicks into place on the hall sensor.
4. Snap the hall sensor onto the stator. (See **Hall Sensor Reassembly** for instructions).

## Diagnosing the Stator

Check from any one of the three stator phase wires to any other stator phase wires, **red, yellow, or blue**. On connector J1203, the resistance should be approximately 18 ohms. If no resistance is present, check the harness and connectors for damage. If the harness and connectors are good, replace the stator.

## Stator Strip Circuit

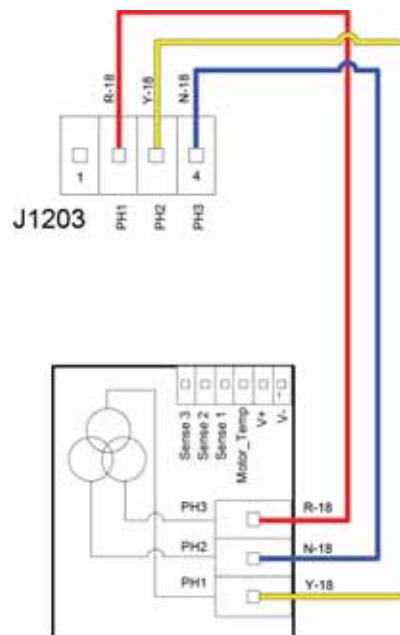

# Hall Sensor

The hall sensor is used to measure the movement and the speed of the rotor assembly. The hall sensor has internal switches that open and close with the movement of the rotor magnets. The hall sensor then sends these measured, pulsating signals back to the inverter board.

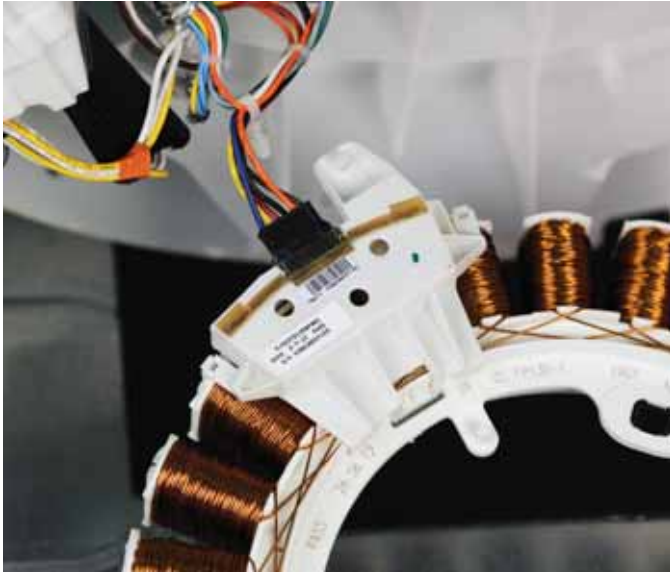

## Hall Sensor Removal

### NOTICE

The hall sensor can be removed without removing the stator.

1. Remove the 11/16 in. rotor nut and pull the rotor off to access the stator.
2. Unplug the connector located on the center of the hall sensor.



3. Unclip the hall sensor from the stator by lifting up from the outer edge, releasing the outer clips. **Use care when releasing the outer clips, as it is possible that they may break when removing. Have a new hall sensor available on the truck before servicing.**

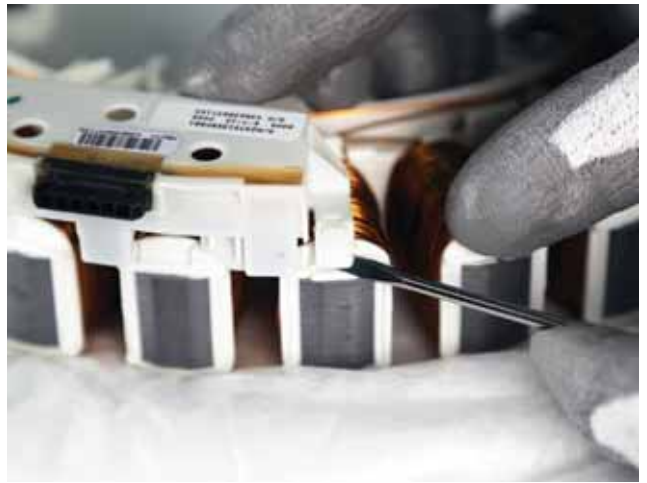

4. Rotate the sensor up to release the inner clip off of the stator.



## Hall Sensor Reassembly

1. To reassemble, push the inside rears clip onto the stator and then clip the two front clips to the outside of the stator. Be sure that the front clips snap into position.
2. Plug the harness connector back onto the hall sensor.

## Diagnostics from the Board – Testing the Hall Sensor

Check from the J1001 connector. With the power to the washer on, and the connector plugged into the inverter board, use a multimeter to verify that a 0 – 12 VDC signal from “P” goes to any one of the three HALL wires on the inverter board while very slowly moving the basket by hand. **CAUTION: There is a potential of -170 VDC from earth ground to “P”.**

## Hall Sensor Strip Circuit

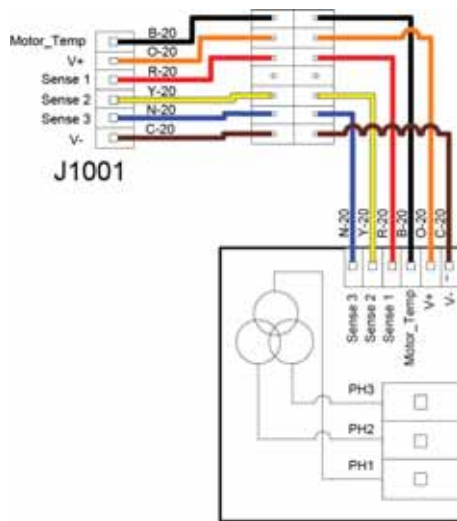

## NOTICE

Terminal “P” at the J1001 connector on the IMC board is referred to as “V” on the mini manual.

## Mode Shifter

The mode shifter consists of a motor, micro switch, spring and clutch. Its purpose is to switch modes of movement, spin or agitate, depending on where in the wash cycle the control is.



When switching from spin to agitate, the mode shifter motor receives 120 VAC from the inverter board. The motor will rotate until the mode shifter motor sense switch closes, signaling to the inverter that the mode shifter has reached the agitate mode.

**Mode Shifter in spin state. This is the home position after a cycle is completed.**





### Mode Shifter in agitate state — Clutch pressed in



2. Remove the three 5/16 in. hex screws.



### Mode Shifter Removal

The mode shifter cannot be removed without removing the stator. (See **Stator Removal** for instructions).

1. Disconnect the harness to the mode shifter and disengage the wire zip tie from the platform.

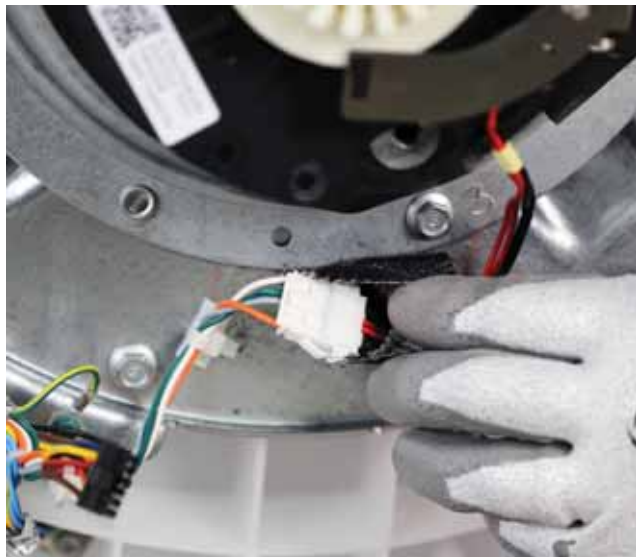

3. Pull the mode shifter up and off the platform.

### Mode Shifter Reassembly

1. The mode shifter will come as a complete assembly. When replacing the mode shifter assembly, be sure to insert the flat washer before sliding the spring on to the shaft of the platform.



2. Slide the motor of the mode shifter into the platform housing opening.
3. When installing the clutch, make sure it moves freely up and down on the shaft while lining up the teeth.
4. Install the three 5/16 hex head screws.
5. The torque for the mode shifter screws is 54 in. pounds.

### Diagnostics from the Board – Mode Shifter Position Switch

The mode shifter motor sense switch can be tested at the J501 connector between the gray and the green wires. The switch is normally open in the idle/spin state. It is closed in the agitate state.

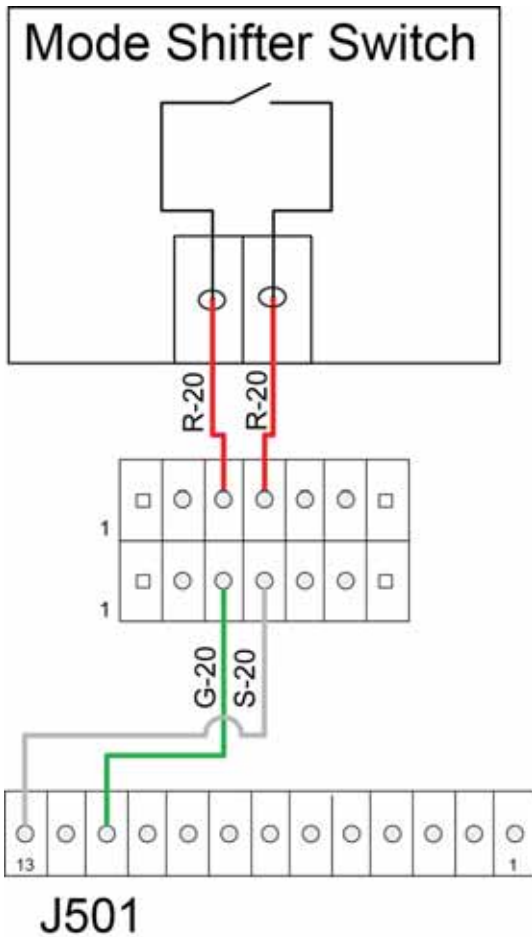

### Diagnostics from the Board – Mode Shifter Motor Resistance

Check the Mode Shifter Motor Resistance from J701 connector **orange** wire to the **white** neutral wire on the J101 connector. Should read approximately 4k ohms.

If Resistance is good, check for 120 VAC at the same locations when activated.

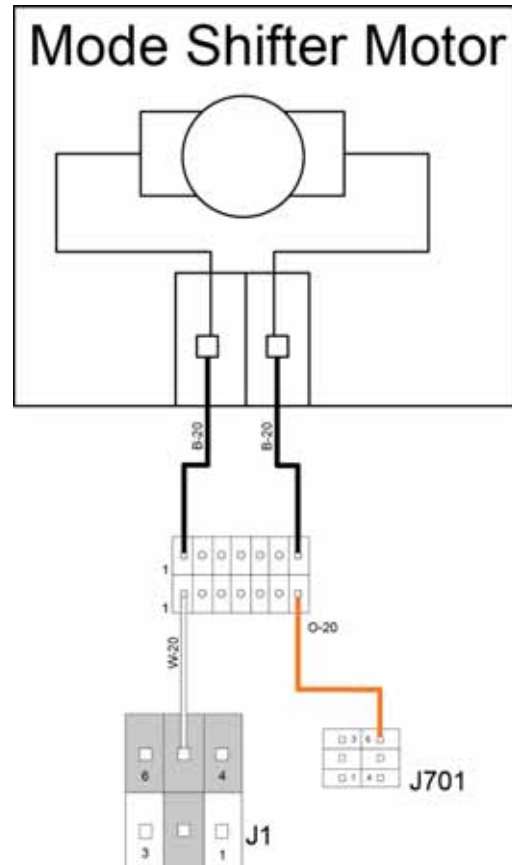

# Platform Assembly

The platform assembly consists of a shaft and a tube, with no gears or grease. If the wash cycle is in agitate mode, the inner shaft will have the only movement. If the cycle is in the spin mode, both the inner shaft and the outer tube will move to allow both the impeller and the basket to turn. This is done from the action of the mode shifter. The platform also acts as the mounting plate for the mode shifter and stator.

## Platform Assembly Removal

1. Remove the impeller. (See **Impeller Removal** for instructions).
2. Remove the 1-5/16 in. hub nut.



### NOTICE

If an impact gun is not being used and a torque wrench is, do not use the torque limiter. The torque limiter tool is used with an impact gun to achieve the proper torque. Use the torque limiter when removing or installing the hub nut to prevent damage to the shaft and tube assembly.

3. Apply tape over the vent hole on the top of the bulk tanks. Also apply tape to the oval shaped dispense holes on the fill funnel. This will prevent detergent/softener leakage when removing the tank or laying the washer on its side.

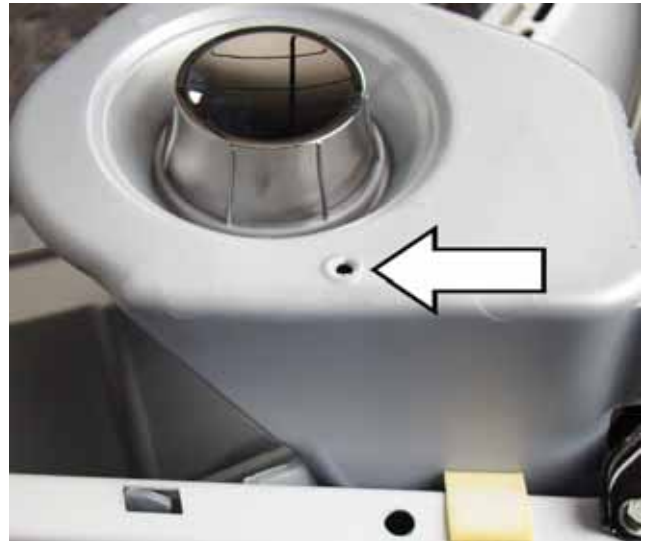

4. Lay the washer on its side.

### CAUTION

Tape the lid closed as it will spring open when laying the washer on its side.

5. Remove all of the components from the bottom of the tub assembly.

6. Remove the twelve 3/8 in. hex bolts.



7. Pry the platform off of the tub assembly. **The design of the tub allows it to be used to aid with prying the platform off of it.**

### Platform Assembly Reassembly

1. When reassembling the platform, insert the orientation post on the tub into the post hole on the platform.

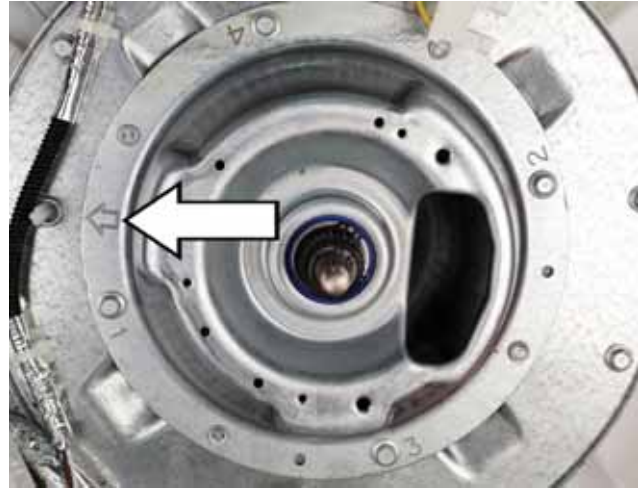

2. Install the platform starting with the inner bolts first. They are numbered 1, 2, 3 and 4. Start with number 1 first.

### NOTICE

It is important to install the platform bolts in this pattern. It allows the tub seal to be pulled into the tub evenly without damaging it.

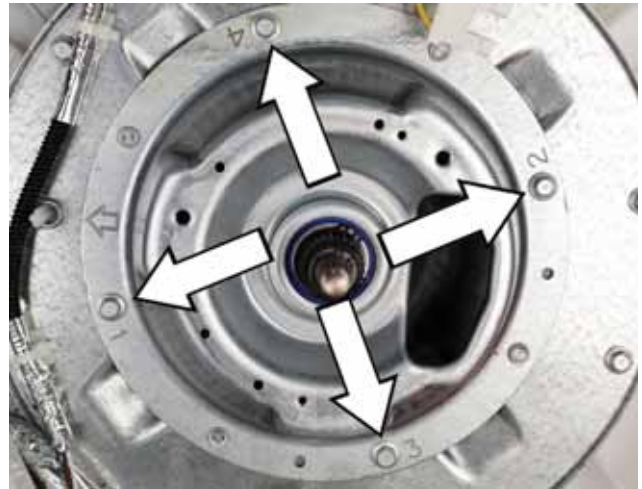

3. Place the bolts, but do not tighten them all the way in. Tighten each bolt 1/4 of the way in at a time. This is done to pull the pressed on seal into the tub assembly evenly.
4. Once the inner bolts are all pulled in, the outer bolts may then be installed. Tighten and torque each to 65 in. pounds.
5. Reinstall all of the components back onto the bottom of the tub assembly.

6. Stand the washer upright.
7. Remove the tape from the vent holes on the bulk tanks and the oval shaped dispense holes on the fill funnel.
8. Reinstall the hub nut. The torque when re-installing the hub nut is 100 ft pounds.
9. Reinstall the impeller with coupler onto the shaft.

# Fill System

## Water Valve Assembly

The water valve is a 120 VAC, compound solenoid type, and is accessed by removing the backsplash assembly. It is inserted and retained in a cutout at the rear of the top cover under the backsplash assembly. It is held in place by 1/4 in. hex head screws. It is only available as a complete assembly.

Flow rates are as follows:

Water Valve Flow Rates	Gallons Per Minute (GPM)
Hot	2.64
Cold	2.64
Bleach	1.32
Detergent	1.32
Softener	2.00
Bulk Detergent	2.00
Bulk Softener	2.00

### Water Valve Removal

1. To replace the water valve remove the backsplash assembly. (See **Backsplash Removal** for instructions).
2. Remove the two 1/4 in. hex screws that hold the fill funnel in place.

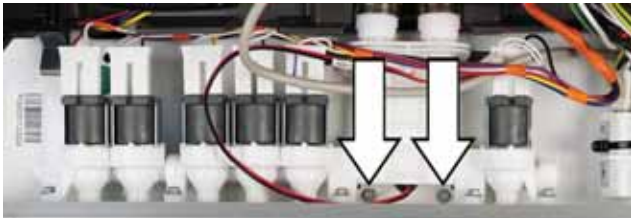

3. Then remove the 1/4 in. hex screws that hold the water valve to the top cover. The number of screws vary depending on the water valve in the washer, from three coils to six coils.



4. Slide the water valve out toward the rear of the washer.
5. Once the water valve is slid out, use pliers to grasp the clamps and turn them until the lobe of the clamp is accessible.



### NOTICE

The tube the clamp is securing may turn with the clamp. This is OK. Although regular pliers will work, click pliers will work better.

6. Once a clamp is oriented, using pliers, grasp the lobe of the clamp and twist. The clamp will break off.



7. The tubes can then be removed from the valve.



## Water Valve Assembly Reinstallation

There are two sizes of replacement clamps in clamp kit WR49X20000, needed for all the tube connections on this washer. The larger of the two clamps are only used for the Fill Funnel Tubes. The smaller of the two clamps is used for all other tubes.

1. Insert the two tubes from the fill funnel through the two large hose clamps. This will hold it in position as the clamps will not go through the hole until they are clamped closed.
2. Then using the smaller clamps, insert the tubes through the clamps and attach the tubes to the water valve barbed stems.



3. After seating the tubes back onto the water valve, orient the click pliers where the thin edge is under the lip of the clamp. That way it will slip under the hook of the clamp. **If the clamp needs to be opened or removed after installing, flip the pliers over so that the thin edge is on the hump and the thick edge of the pliers is on the lip and clip portion of the clamp. Squeeze the pliers until the click clamp snaps open.**



4. Squeeze the clamp until it snaps together.



5. Make sure that the clamp is closed.



6. Reinstall the water valve to the top cover.

There are three different water valves that accommodate three different dispenser configurations.

- For the GTWN7450 models, the 3 coil valve is used.
- For the GTWN815 – GTWN845 models, the 5 coil valve is used.
- For the GTWS865 models, the 6 coil valve is used.

## Diagnosing the Water Valve

- If no water is coming out of the valve, check the inlet hoses and water valve screens to make sure they are not clogged.
- If water is still not coming out of the valve, put the control into **Service Mode** and apply voltage to the water valve coil that is not working. Check for 120 VAC on the corresponding colored wire at the J702 connector on the inverter board to the **white** wire at the J101 on the inverter board. Also, the resistance of the coil can be checked at those same connectors. The resistance should read approximately 1k ohms (1000 ohms).
- If no resistance is present, check for resistance at the coil. This will verify whether or not there is an open harness.

### NOTICE

“H2O Supply” scrolling on the control is caused by the control not sensing water going into the tub.

If the water is going into the tub, check the pressure sensor readings with NewFi or by checking the Hz output from the pressure sensor in approximate comparison to the amount of water in the tub. Check the harness and the connections along with the pressure sensor tube.

If no water is flowing into the tub, check the house water supply. Make sure that it is turned on, and that the house doesn't just have low water pressure.

If water is still not flowing into the tub, or only a low amount of water is flowing into the tub, check the hose screens for debris. If debris is present, clean the hose screens. Also check the hoses for kinks.

If there is still no water or a low amount of water flowing into the tub, check or clean the water valve screens.

If still no water is flowing, replace the water valve.

## Water Valve Assembly Strip Circuits

### Water Valve Assembly 7450

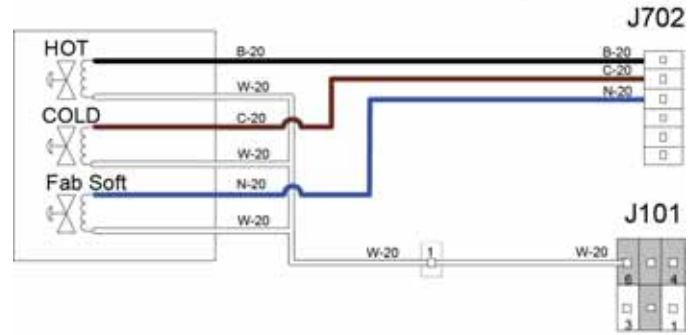

### Water Valve Assembly 82XX-84XX

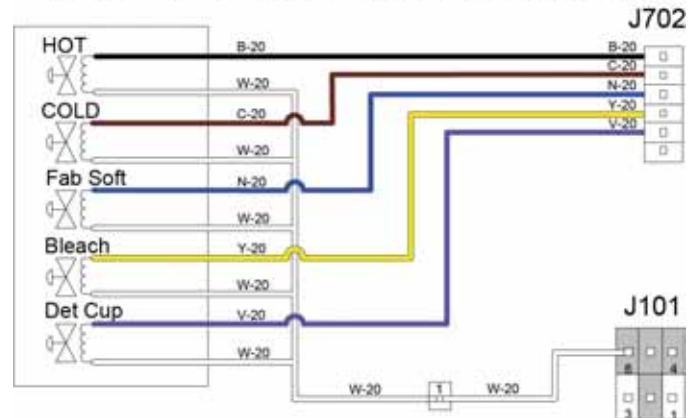

### Water Valve Assembly 86XX

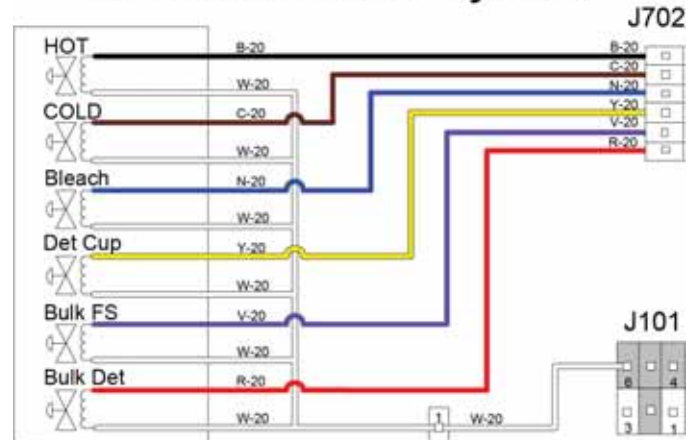

### NOTICE

On the **white** neutral wire going to the water valves, there is an in-line connector between the J101 connector on the inverter board and the water valve.

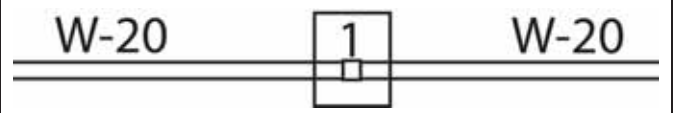



# Pressure Sensor

For models equipped with a pressure sensor, the pressure sensor status will be determined by reading the frequency coming from the pressure sensor.

## Pressure Sensor Removal

1. The pressure sensor is located in the backsplash area. Remove the backsplash assembly.\* (See **Backsplash Removal** for instructions). \**With the tub in an empty state.*
2. Use pliers to compress the locking tab that is holding the sensor in its housing, and onto the backsplash bottom.



3. Disconnect the sensor wire connector by pushing up on the tab above the wire connector and pull the connector from the sensor.

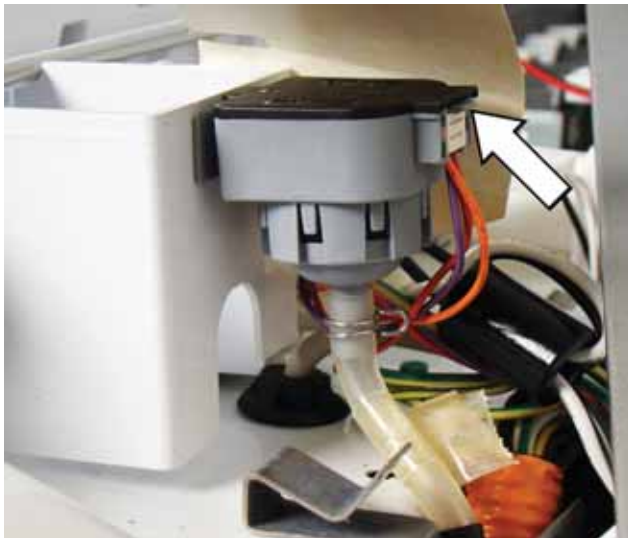

## Pressure Sensor Reinstallation

1. To reinstall the pressure sensor, reconnect the pressure tube to the sensor, and also to the harness connector.
2. Push the clip of the pressure sensor back onto the backsplash bottom.

## Pressure Sensor Diagnostics

If the pressure sensor's frequency is outside of the "Valid Values" illustrated in the **Tub Water Level / Hz Conversion** chart, then an error condition is set. The error condition will be logged in **Service Mode**.

If a Pressure Sensor error occurs during a cycle, the cycle will be canceled and the control should go to an **Idle** state.

If a cycle is started during a Pressure Sensor error, the fill cycle will be cancelled.

## Pressure Sensor Testing

Use a hertz meter to read the frequency at specified water levels.

For testing at the pressure sensor, the pin out is as follows:

1 = Ground
2 = Signal
3 = 5V

Test between pins 1 and 3 to verify that 5 VDC is going to the sensor. This is needed to be able to read the signal coming from the sensor.

Test between pins 1 and 2 to measure the signal.

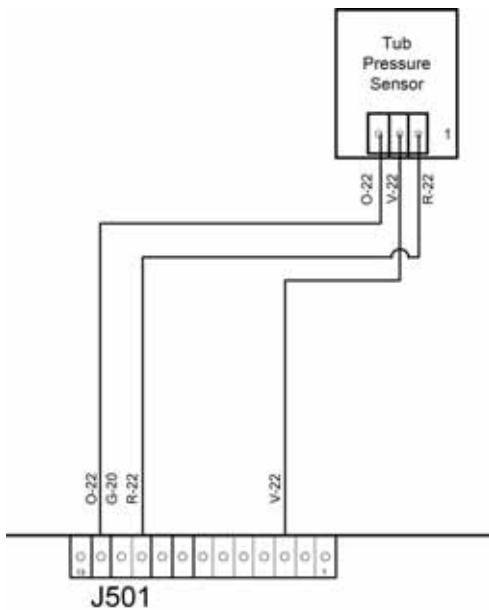

## Tub Water Level / Hz Conversion

Inches of Water	Frequency Hz
Pumped out tub	45.2
1" in basket	44.2
3" in basket	43.3
6" in basket	42
9" in basket	40.7
12" in basket	39.4

## Water Levels

Water levels can vary depending on the load being washed. This can be attributed to the weight of the items in the load, which is what sets the water level in most cycles.

The level will vary from a minimum of 7 gallons to 25 gallons.

### NOTICE

Water should always cover all valley areas (as shown below) when a cycle is run with an empty basket. There are four valley areas located between the fins of the impeller. The valley areas can be identified on the impeller by the four sections with holes, which are designed to help circulation within the basket.

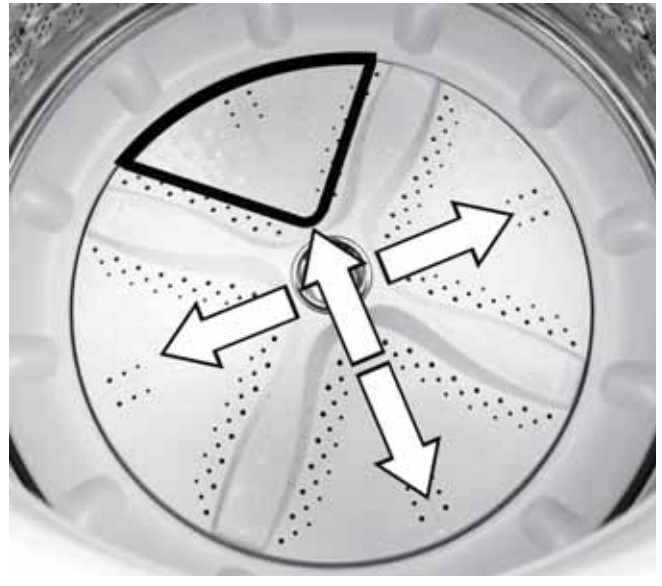

If there is less than 7 gallons in the basket, then water pressure from the home supply, or debris in the water valve or hose screens may be the cause.

# Top Cover Dispenser Cups

## Triple Dispenser Cup Assembly

The dispenser cups are used to either direct the fluid into the tub assembly immediately during the cycle, or to hold the fluid and dispense at a specific time in the cycle. This occurs by flushing the dispenser cups with water from the water valve.



The liquid bleach and softener cups will dispense at certain points in the cycle. The bleach cup will dispense close toward the end of the wash cycle. It is timed like this so the surfactant in the detergent has more time to absorb dirt. The softener cup will dispense in the final rinse when selected. After the water is shut off to the specified cup, the contents in the cup will continue to siphon out until the cup is empty. Water will enter the cups several times to completely flush the contents out.

## Diagnosing Dispenser Cups

To diagnose the dispenser cups, put the control into Service Mode and turn the individual water valve coil on to the dispenser cup. This will allow water into the cup to be dispensed. Depending on the type of cup (either flow through or siphon), it will flow right through or fill the cup to start the siphon.

## Dispenser Cup Removal

1. With the top cover still installed, remove the dispenser bezel by pulling it upward.



2. Once the cup bezel is removed, remove one Phillips screw that holds the cup in place.



3. Slide the dispenser cup toward the front of the washer to disengage cup lips from the top cover.



4. Pull the cup between the top of the tub and the top cover and disconnect the tubes going to it. Be sure to note where each tube connects to the dispenser cup for reinstallation.



#### Dispenser Cup Reassembly

1. Install the tube on to the new cup using the small click clamp. (Refer to the click clamp instructions found in **Water Valve Assembly Reinstallation**).
2. Slide the new dispenser cup under the top cover into the opening provided for it. Be sure that the lip of the cup is on the top side of the top cover.
3. Reinstall the Phillips screw that prevents the cup from sliding out of position.
4. Push the dispenser bezel onto the cup until it snaps into position.

# Bulk Dispenser Tanks

## Bulk Dispenser Tanks Operation

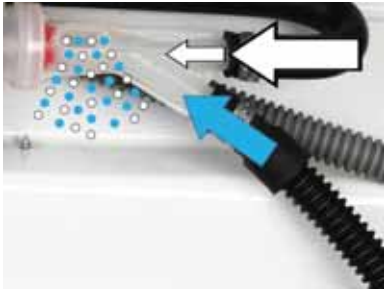

Water enters the fill funnel from the water valve. The tube on the fill funnel narrows (Venturi), which then creates a pressure. When the pressurized water flows through to the oval opening in the fill funnel, it causes a suction. It is this suction that pulls the detergent and/or softener from the bulk tank through the bulk tank sensor, to the fill funnel mixing with the water.

## Bulk Detergent/Softener Tanks

The bulk detergent tank and the bulk softener tank each hold over a gallon (140 ounces or 4100 ml) of liquid. After filling the tank, press the **Detergent Tank On** button to turn on its light and designate bulk (rather than manual) detergent dispense.

The **Tank Levels** lights (five total) indicate how much detergent is left. An empty tank is shown by a single red light. A full (or nearly full) tank is shown by five lights.

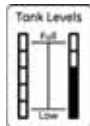

## NOTICE

If **Start** is pressed when the tank is empty, the **Detergent Tank On** light and the red **Tank Levels** indicator light for the tank that is empty will flash four times, along with the **Start** button.

A beep will also sound if **Variable Signal** is on. The **Start** button will continue to flash approximately 30 seconds longer, and then will turn off the control.

The **Detergent Cup Amount** lights indicate if a *Low*, *Medium*, or *High* amount will be dispensed.

Detergent will be automatically dispensed at the optimum time at the beginning of each fill cycle.

## Set the Bulk Detergent Cup Amount Preference

When the **Detergent Tank On** light is on, pressing the **Detergent Cup Amount** button will set the **Detergent Cup Amount** lights (1, 2, or 3).

- Level 1 will distribute the standard amount minus 25%.
- Level 2 will distribute the standard amount.
- Level 3 will distribute the standard amount plus 25%.

## Examples:

Factory default standard amount is 1.5 oz (44 ml) ( <b>Concentration Setting 15</b> ).													
If <b>Detergent Cup Amount</b> shows 3 lights then 1.9 oz (55 ml) will be dispensed.	<table border="1"> <thead> <tr> <th colspan="2">Concentration Setting</th> <th>15</th> </tr> </thead> <tbody> <tr> <td>3 lights:</td> <td></td> <td>1.9 oz.</td> </tr> <tr> <td>2 lights:</td> <td></td> <td>1.5 oz.</td> </tr> <tr> <td>1 light:</td> <td></td> <td>1.1 oz.</td> </tr> </tbody> </table>	Concentration Setting		15	3 lights:		1.9 oz.	2 lights:		1.5 oz.	1 light:		1.1 oz.
Concentration Setting		15											
3 lights:			1.9 oz.										
2 lights:		1.5 oz.											
1 light:		1.1 oz.											
If <b>Detergent Cup Amount</b> shows 2 lights then 1.5 oz (44 ml) will be dispensed.													
If <b>Detergent Cup Amount</b> shows 1 light then 1.1 oz (33 ml) will be dispensed.													

Factory default standard amount is 1.0 oz (30 ml) ( <b>Concentration Setting 10</b> ).													
If <b>Softener Cup Amount</b> shows 3 lights then 1.3 oz (37 ml) will be dispensed.	<table border="1"> <thead> <tr> <th colspan="2">Concentration Setting</th> <th>10</th> </tr> </thead> <tbody> <tr> <td>3 lights:</td> <td></td> <td>1.3 oz.</td> </tr> <tr> <td>2 lights:</td> <td></td> <td>1.0 oz.</td> </tr> <tr> <td>1 light:</td> <td></td> <td>0.8 oz.</td> </tr> </tbody> </table>	Concentration Setting		10	3 lights:		1.3 oz.	2 lights:		1.0 oz.	1 light:		0.8 oz.
Concentration Setting		10											
3 lights:			1.3 oz.										
2 lights:		1.0 oz.											
1 light:		0.8 oz.											
If <b>Softener Cup Amount</b> shows 2 lights then 1.0 oz (30 ml) will be dispensed.													
If <b>Softener Cup Amount</b> shows 1 light then .8 oz (22 ml) will be dispensed.													

**NOTE:** Each cycle knob position defaults to a different **Detergent Cup Amount** (including 0 if no detergent is used). If the **Soil** setting is changed, the **Detergent Cup Amount** may change. The user can then manually change the **Detergent Cup Amount**, but the change will *not* be saved when the user leaves this knob position or if a **My Settings** is set.

## Setting The Bulk Tank Detergent/Softener Concentration

To set the concentration level you need to enter the Special Features mode:

To enter the bulk tank Special Features mode:

1. Press the Power button.
2. Simultaneously press and hold either:
  - **Detergent Tank On** and **Detergent Cup Amount** buttons for three seconds
  - **Softener Tank On** and **Softener Cup Amount** buttons for three seconds

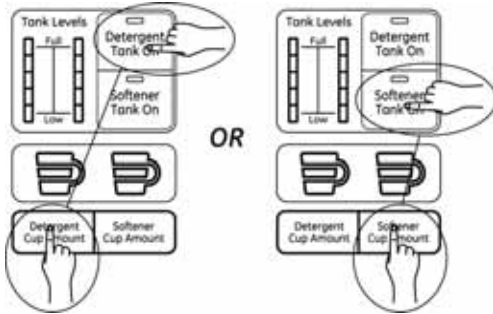

The **My Settings** and **Extra Rinse** lights will flash to indicate you are in the *Special Features Mode*.

## Set Concentration Settings

### NOTICE

During initial installation, or if the household water pressure dramatically changes, the bulk dispenser will change to accommodate the homes' unique water pressure. Wait a few wash cycles before changing concentrations.

The factory default concentration settings are 1.5 oz (44 ml) for detergent and 1.0 oz (30 ml) for softener. To allow maximum user flexibility either of these can be changed to between 0.5 and 10 ounces.

1. Enter **Special Features** mode.
2. Press the **My Settings** button.

The **My Settings** and the chosen (Detergent or Softener) three **Cup Amount** lights will come on and the **Extra Rinse** light will go out. The display will show "10 times in ounces" the current concentration setting (e.g. 15 represents 1.5 ounces). This amount will be dispensed when two (of the three) **Cup Amount** lights are lit.

3. Turn the cycle knob clockwise to increase or counter-clockwise to decrease the setting (within preset limits). Each click increases or decreases Level 2 (standard amount) by a 1/2 ounce. Levels 1 & 3 change proportionally.

4. Press the **Cup Amount** button to save the new setting.

This function will then exit and the display will reflect whatever cycle the cycle knob is on.

To exit without changing the setting, press the **Power** button. This function will automatically exit (without saving) if neither button is pressed within one minute.

The following table shows the approximate amount dispensed in ounces (oz) at each **Cup Amount** setting (1, 2 or 3) for each **Concentration Setting**:

Concentration Setting	5	10	15	20	25	30	35	40	45	50	55	60	65	70	75	80	85	90	95	100
Number of Loads*	200	100	67	50	40	33	29	25	22	20	18	17	15	14	13	13	12	11	11	10
	0.6	1.3	1.9	2.5	3.1	3.8	4.4	5.0	5.6	6.3	6.9	7.5	8.1	8.8	9.4	10.0	10.6	11.3	11.9	12.5
	0.3	1.0	1.5	2.0	2.5	3.0	3.5	4.0	4.5	5.0	5.5	6.0	6.5	7.0	7.5	8.0	8.5	9.0	9.5	10.0
	0.4	0.8	1.1	1.5	1.9	2.3	2.6	3.0	3.4	3.8	4.1	4.5	4.9	5.3	5.6	6.0	6.4	6.8	7.1	7.5

\* For a 100 oz (2957 ml) bottle for normal setting.

## NOTICE

Apply tape over the vent hole on the top of the bulk tank.



Also apply tape to the oval shaped dispenser hole on each end of the fill funnel.



Doing this prevents detergent leakage when removing the tank or laying the washer on its side. After taping the vent hole, lay a rag under the tank flange (where the tube connects to the tank) before disconnecting the tube to catch the small amount of detergent that will come out. Then tape or plug the tank flange hole to prevent spillage.

## Bulk Dispenser Tank Removal

1. The bulk dispenser tank can be removed from the bottom of the washer.
2. Lean the washer back using ergo assisting prop blocks or by laying the washer on its side.



3. Pull the tank out from the bottom by lifting the tank up and off of the bottom apron lip. Slide the tank down and out of the outer wrapper at a 45 degree angle.



4. Remove the hose clamps at the bottom of the bulk tank. (Refer to the click clamp instructions found in **Water Valve Assembly Reinstallation**). If there is fluid still in the tank, block the opening where the tube connects to the tank with thumb to prevent any leakage from the tank. Also have a towel under it to prevent a mess on the floor.

## Bulk Dispenser Tank Reassembly

1. With the washer still leaning back or laying on its side, slide the tank in at a 45 degree angle. Make sure to reconnect the hose back to the tank using a small click clamp.
2. Slide the tank up and in alongside the front corner of the cabinet.
3. Maneuver the top of the tank around the front suspension rod.
4. Once the top of the tank is in place, it will lock into position.
5. Once locked into position at the top, apply pressure while pushing the tank in until both tank posts are secured on the bottom lip of the cabinet. Once locked in, the pressure will hold the tank in position and also prevent the tank from rattling on the cabinet.

## Bulk Tank Pressure Sensors

The bulk tank pressure sensors, one for each tank, are located at the back of the unit. They are mounted to a plastic bracket that sits over the rear leg posts. Slots in the bracket hold them in place to the cabinet. The sensors are used to measure the amount of fluid that is in the bulk tanks.

### Pressure Sensor for Bulk Tanks Removal

1. To remove the pressure sensor for bulk tanks, either lean the unit back or open the rear panel.



2. Lift the sensor and bracket assembly up and off of the leg post.





- Using the pinch off pliers, pinch off the tube coming from the bulk tank to the sensor. Disconnect the tube for the sensor by breaking the clamp off and then removing the tube. (Refer to the click clamp instructions found in **Water Valve Assembly Reinstallation**).



- Pull the sensor straight up off of the mounting bracket.



- Disconnect the wire connector from the sensor.



- Remove the remaining hose that leads to the fill funnel.

### **Tank Pressure Sensor Reassembly**

- To reinstall the sensor, push the tubes with new click clamps onto the sensor.
- Use the click pliers to click the clamps shut. (Refer to the click clamp instructions found in **Water Valve Assembly Reinstallation**).
- Push the sensor back onto the plastic bracket and then slide the bracket over the leg post onto the outer wrapper.



## Tank Pressure Sensor Diagnostics

If no liquid is being dispensed from the bulk tanks, check the water valve operation in the **Service Mode**. Make sure the tanks are full, and that the water pressure going to the tub is good. The hose or water valve screen could be clogged. Check the bulk tank pressure sensors to make sure that they are in range, that they are connected, and that power is going to them. If there is no power, check for a broken wire to the sensor.

### NOTICE

If the bulk tanks are empty of either fabric softener or detergent, the tank level indicators will flash three times, and the cycle will not start. This can be bypassed by turning off the bulk tanks, and applying detergent manually.

Diagnosing the bulk tank sensors can be done at the sensor or from the J502 connector on the IMC board.

Use a hertz meter to read the signal at specified tank fluid levels.

For testing the pressure sensor, the pin out is the same as the pressure sensor for the basket water levels and are as follows:

1 = Ground

2 = Signal

3 = 5V

Test between pins 1 and 3 to verify that 5 VDC is going to the sensor. This is needed to be able to read the signal coming from the sensor.

Test between pins 1 and 2 to measure the signal.

## Bulk Tank Pressure Sensors Strip Circuit

### Bulk Tank Sensors 86XX

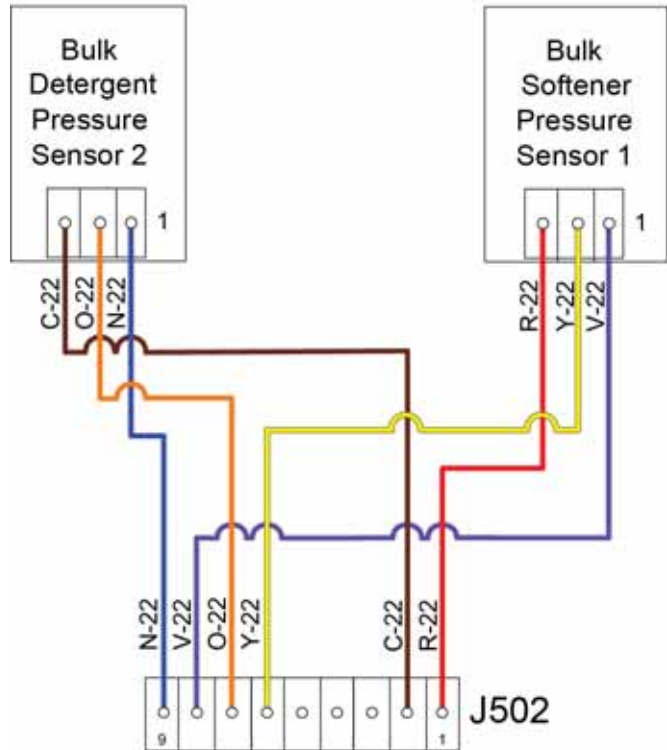

### Bulk tank pressure sensors

Inches of Fluid	Frequency Hz
0	1380
2	1362
6	1331
9.5	1269
20	1220

# Tub Thermistor

The thermistor is used to sense the water temperature in the tub, and also for the steam assist cycle.

**IF THE TEMPERATURE NEEDS TO BE TAKEN, WAIT AT LEAST TWO MINUTES AFTER AGITATION/RECIRCULATION HAS BEGUN.**

## Tub Thermistor Removal

1. The thermistor is located in the bottom of the outer tub assembly, next to the drain pump. Remove the two 5/16 in. hex screws to remove the thermistor.



2. Once the tub thermistor is removed, there are two different possible configurations for the harness wiring to the thermistor. Some models may present a separate **yellow** wire connected to a ring terminal mounted underneath one of the thermistor assembly screws. Some units may not have a separate **yellow** wire.

Unit with separate **yellow** wire.



Unit with no separate **yellow** wire.



3. If the **yellow** wire with the ring terminal is present, carefully lift it out of the way and protect it from damage. It will be reinstalled in the same location in a later step.

4. Cut both **azure** (blue) wire leads flush with the rear black seal of the old tub thermistor to keep the **azure** leads coming from the harness as long as possible.
5. The leads are interchangeable when splicing so there is no need to label them.

## Tub Thermistor Reassembly

1. Splice the thermistor back onto the main harness.
2. Slide the new thermistor into the tub assembly.
3. Fasten the new thermistor with the two 5/16 in. hex screws.
4. If there is a **yellow** wire with a connector on it, slide it onto the hex screw before installing the hex screws through the thermistor.

## NOTICE

Make sure the rubber O-ring is in place before reinstalling the new thermistor into the tub.

5. Torque the hex screws to 17 in. pounds.

## Thermistor Diagnostics from the IMC board.

To test the thermistor with the tub empty, take the ambient room temperature with a thermometer to see if the thermistor is within plus or minus 5 degrees. If good, turn on the TAP COLD water into the tub and measure the incoming water temperature at the fill funnel. The thermistor reading should drop to within what the thermometer is reading, plus or minus 5 degrees.

From the J501 connector, check thermistor resistance between the two **azure** wires.

## Tub Thermistor Strip Circuit

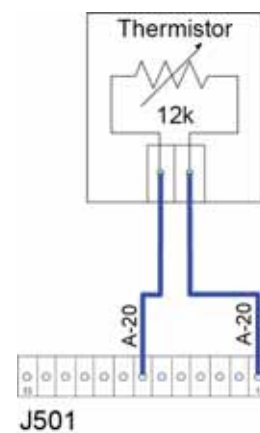

**Thermistor Resistance Table**

**(These values are read from the leads while disconnected from the control PCB)**

Temp (degC)	Temp (degF)	Resistance
10	50	22166
15.5	60	17407
21	70	13840
27	80	10780
32	90	8878
38	100	7040
43	110	5610
49	120	4700
54	130	3900
66	150	2620
77	170	1840

# Wash System

## Recirculation Pump

The recirculation pump is used to spray water over the wash load during the wash cycle, and to rinse during the rinse cycle.

### Recirculation Pump Removal

1. To remove the recirculation pump, access the bottom of the washer, and disconnect the wire harness from the pump.



2. Remove the recirculation tube and hose from the pump. Use the pinch off pliers to secure the hose going from the tub to the pump before disconnecting the hoses from the pump.



3. Remove one 3/8 in. hex bolt.
4. Lift up slightly and slide the pump bracket out from under the platform.

### Recirculation Pump Reassembly

1. To reinstall the recirculation pump, slide the pump bracket under the platform first.
2. Reinstall the 3/8 in. hex bolt. Torque is 65+/-20 in. pounds.
3. Reconnect the hose and the wire harness connector to the pump.

### Recirculation Pump Thermal Cut Off (TCO)

The recirculation pump thermal cut off (TCO) is a safety thermostat used for this pump in case of a thermal issue with the pump. This is a one shot TCO. If it does open for any reason, replace it and the recirculation pump.

### Recirculation Pump Diagnostics from the IMC board

1. Disconnect power to the washer.
2. Access the control.
3. Disconnect the J701 connector.
4. Check the resistance from the **brown** wire to the neutral **white** wire at the J101 connector.
5. Should read approximately 30.5 ohms.
6. If resistance is good, check for 120 VAC at the same locations when activated, while in Service Mode.

## Recirculation Pump Strip Circuit

### Recirculation Pump 8XXX and Higher

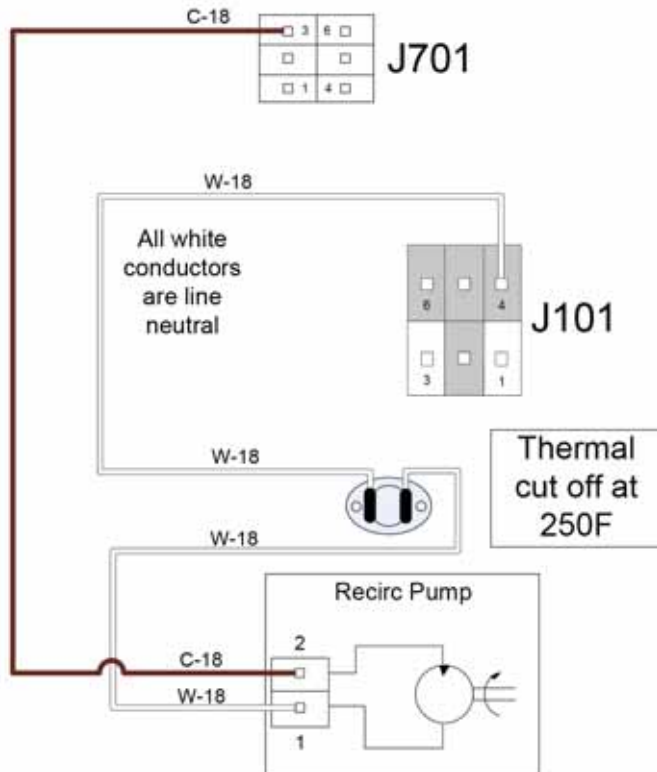

## Recirculation Tube

The recirculation tube is connected to the recirculation pump with a spring clamp. From the front of the washer, the recirculation tube is mounted to the left rear side of the tub assembly, and is pushed into a rubber grommet at the top of the tub assembly. The recirculated water is then sprayed into the tub with the assistance of the tub cover at that same location.

### Recirculation Tube Removal

1. To remove the recirculation tube, disengage the spring clamp from the recirculation pump and pull the tube off of the pump.
2. Then pull down on the tube to remove from the tub assembly.



### Recirculation Tube Reassembly

1. To reinstall the recirculation tube, push the top of the tube with the rubber grommet in to the top of the tub assembly.
2. Put the clamp onto the new tube and then push the tube onto the recirculation pump.
3. Slide the spring clamp back into position so that it holds the tube to the pump.

# Drain System

## Drain Pump

The Drain Pump is a 120 VAC pump used to expel water from the tub assembly to the house drain. The maximum drain height that it will pump out to is 8 ft.

### Drain Pump Removal

1. To remove the drain pump, disconnect the wire harness connector from the pump.
2. Pinch off the hose that comes from the tub to the pump. Remove the drain hoses from the pump.
3. Remove the one 3/8 in. hex bolt.

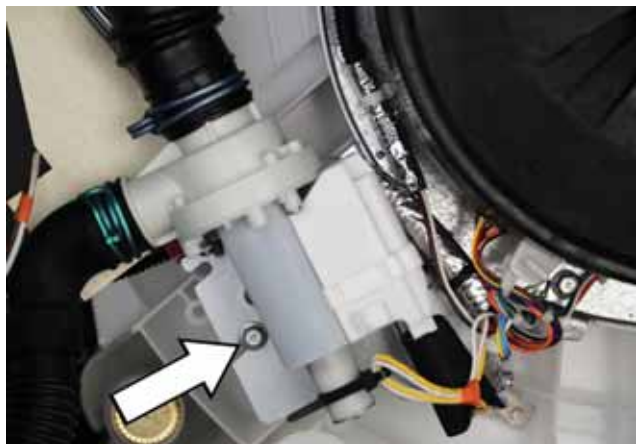

4. Lift up slightly on the bracket and then slide the drain pump out from under the platform.

### Drain Pump Reassembly

1. To reinstall either pump, slide the pump bracket under the platform first.
2. Reinstall the 3/8 in. hex bolt. Torque is 65+/-20 in. pounds.
3. Reconnect the hoses and the wire harness connector to the pump.

### Drain Pump Diagnostics

Disconnect power to the washer. Access the control. Disconnect the J701 connector.

Check the resistance from the **yellow** wire to the **white** wire at the **J101** connector. Should read approximately 16.5 ohms.

If resistance is good, check for 120 VAC at the same locations while in **Service Mode**.

### Drain Pump Diagnostics from the IMC Board

1. Disconnect power to the washer.
2. Access the control.
3. Disconnect the J701 connector.
4. Check the resistance from the **yellow** wire to the **white** wire at the J101 connector.
5. Should read approximately 16.5 ohms.
6. If resistance is good, check for 120 VAC at the same locations while in **Service Mode**.

### Drain Pump Strip Circuit

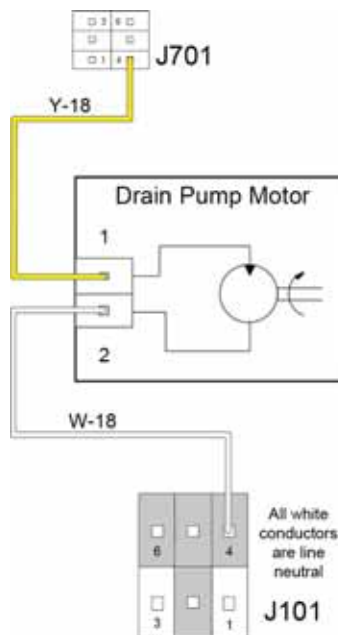

## Drain Hose

The drain hose is used to direct the water being expelled from the tub by the drain pump to the house drain or standpipe.

### Drain Hose Removal

1. To remove the drain hose, squeeze the spring clamp and slide it up onto the drain hose, past where it clamps onto the drain pump and then remove the drain hose from the drain pump.

### NOTICE

Have a pan or towels under the hose when disconnecting to catch any excess water in the drain hose.

2. Unclip the two wire ties that hold the drain hose to the rear of the outer wrapper and remove the drain hose from the drain box on the rear of the washer.

### Drain Hose Reassembly

1. To reinstall, slide the drain hose into the bottom hole on the drain box.



2. Reconnect the spring clamps onto the drain pump and hose. Install new wire ties onto the drain hose and fasten them into the rear outer wrapper.
3. Place the drain hose back into the house drain or standpipe.

### NOTICE

Improper placing of the drain hose can cause a siphoning action. No more than seven inches of hose should be in the house stand pipe. There must be an air gap around the drain hose. A snug fit can also cause a siphoning action.

The drain hose must exceed 32 in. at some point between the washer back and drain. If this height is not obtained, the washer may not operate properly. If a longer drain hose is required, order the drain hose extension kit. Connect the additional drain hose (contained in the kit) to the original hose with the hose clamp (also contained in kit).



# Schematics

\*Schematics also found on the Mini (“Maxi”) Manual.

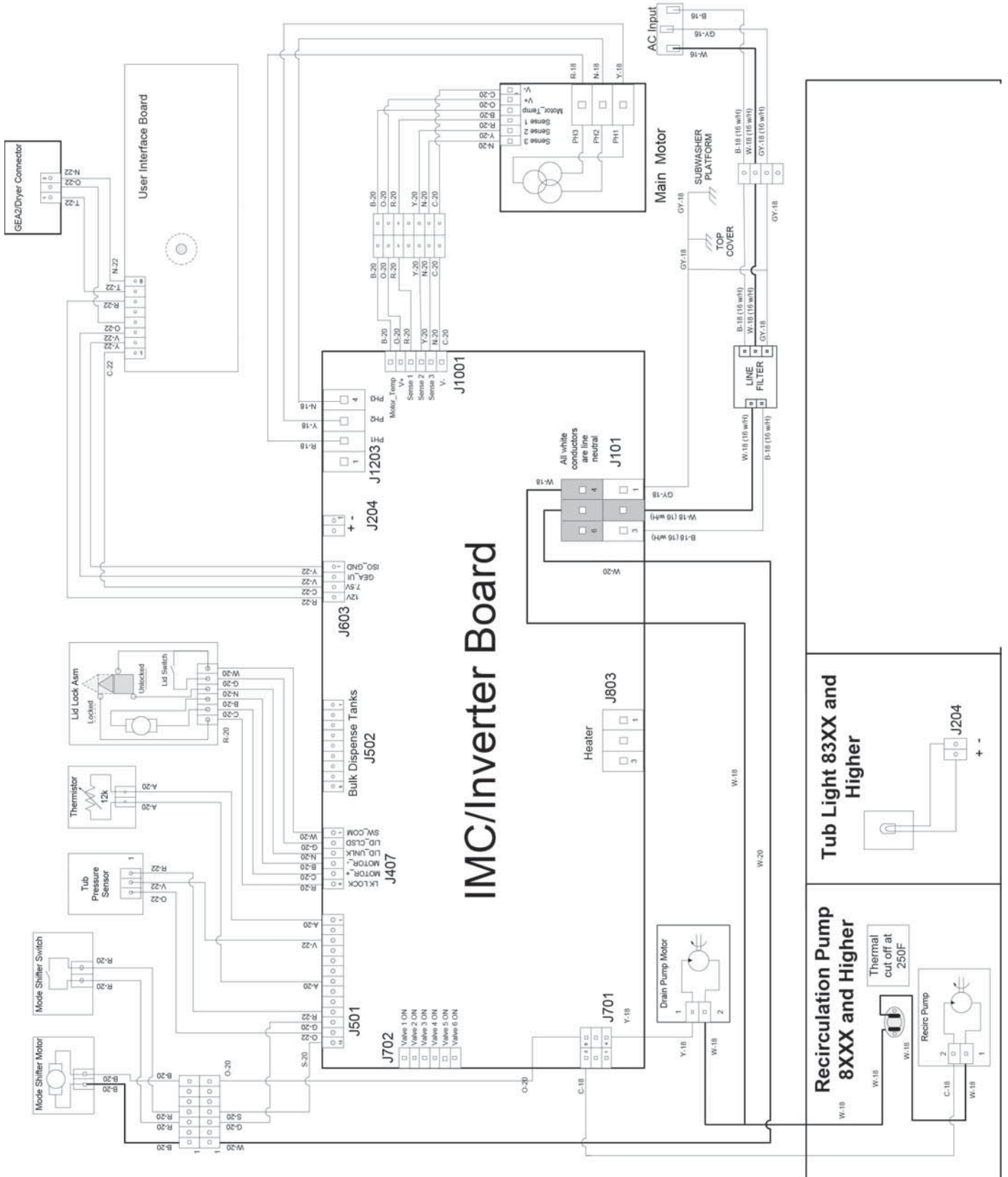

### Wire Color Key

XX:YY  
 XX:Wire color  
 YY:Wire gauge

---

W:White  
 B:Black  
 S:Grey  
 N:Blue  
 Y:Yellow  
 G:Green  
 GY:Green with Yellow

C:Brown  
 R:Red  
 P:Pink  
 V:Purple  
 O:Orange  
 A:Aqua

(XX w/H) – Denotes alternate wire gauge in models equipped with heaters

### Water Valve Assembly 82XX-84XX

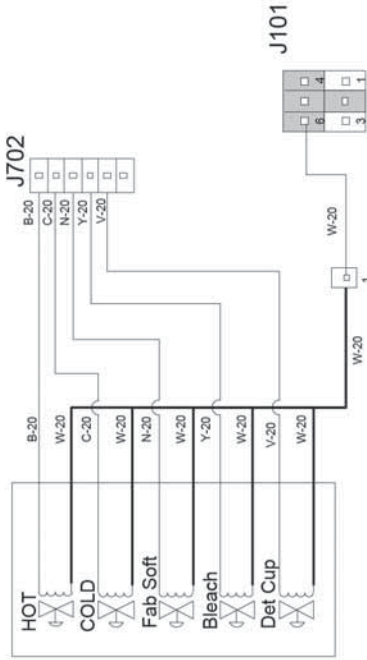

### Water Valve Assembly 86XX

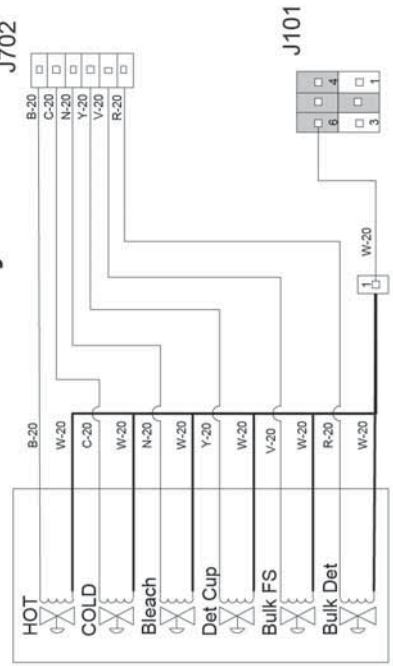

### Tub water level pressure sensor

Inches of Water	Frequency Hz
Pumped out tub	45.2
1" in basket	44.2
3" in basket	43.3
6" in basket	42
9" in basket	40.7
12" in basket	39.4

### Thermistor Resistance Table

(these values are read from the leads while disconnected from the control PCB)

Temp (degC)	Temp (degF)	Resistance
10	50	22166
15.5	60	17407
21	70	13840
27	80	10780
32	90	8878
38	100	7040
43	110	5610
49	120	4700
54	130	3900
66	150	2620
77	170	1840

### Resistance Table

(these values are read from the leads while disconnected from the control PCB)

Component	Resistance
Water Valve coil	1000
Mode shifter motor	3800
Drain Pump	16.5
Recirculation pump	30.5
Heater	12
Motor (phase to phase)	17

### Bulk Tank Sensors 86XX

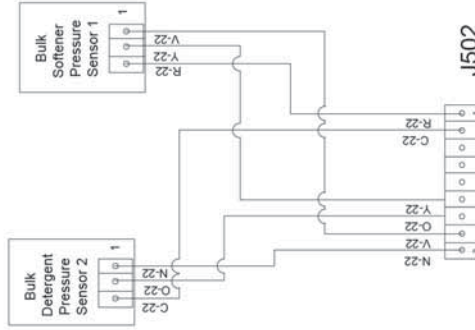

### Bulk tank pressure sensors

Inches of Fluid	Frequency Hz
0	1380
2	1362
6	1331
9.5	1269
20	1220

# GE Top Load Washer Warranty



All warranty service provided by out Factory Service Centers or an authorized Customer Care® technician. To schedule service, visit us on-line at [GEAppliances.com](http://GEAppliances.com), or call 800.GE.CARES (800.432.2737). Please have serial number and model number available when calling for service.

Staple your receipt here.  
Proof of the original purchase date is needed to obtain service under the warranty.

## For The Period Of:

## GE Will Replace:

### One Year

From the date of the original purchase

**Any part** of the CleanSpeak™ Top Load Washer which fails due to a defect in materials or workmanship. During this **limited one-year warranty**, GE will also provide **free of charge**, all labor and in-home service to replace the defective part.

## What GE Will Not Cover

- Service trips to your home to teach you how to use the product
- Improper installation, delivery or maintenance
- Replacement of house fuses or resetting of circuit breakers
- Product not accessible to provide required service
- Damage to the product caused by accident, fire, floods or acts of God.
- Failure of the product if it is abused, misused, or used for other than the intended purpose or used commercially
- Incidental or consequential damage caused by possible defects with this appliance.
- Cleaning or servicing of the air gap device in the drain line.
- Damage caused after delivery, including damage from items dropped on the door.

**EXCLUSION OF IMPLIED WARRANTIES – Your sole and exclusive remedy is product repair as provided in this Limited Warranty. Any implied warranties, including the implied warranties of merchantability or fitness for a particular purpose, are limited to one year or the shortest period allowed by law.**

This warranty is extended to the original purchaser and any succeeding owner for products purchased for home use within the USA. If the product is located in an area where service by a GE Authorized Servicer is not available, you may be responsible for a trip charge or you may be required to bring the product to an Authorized GE Service location for service. Proof of original purchase date is needed to obtain service under the warranty. In Alaska, the warranty excludes the cost of shipping or service calls to your home.

Some states do not allow the exclusion or limitation of incidental or consequential damages. This warranty gives you specific legal rights, and you may also have other rights which vary from state to state. To know what your legal rights are, consult your local or state consumer affairs office or your state's Attorney General.

**Warrantor: General Electric Company, Louisville, KY 40225**

