



# Refrigerator

## Use & Care Guide

### Table of Contents

	<b>Important Safety Instructions</b> ..... 1-2
	<b>Installation</b> ..... 3-9
	<b>Temperature Controls</b> ..... 10-12
	<b>Fresh Food Features</b> ..... 13-15
	<b>Freezer Features</b> ..... 15
	<b>Ice And Water</b> .....16

	<b>Water Filter</b> .....17-18
	<b>Food Storage Tips</b> ..... 19-21
	<b>Care and Cleaning</b> ..... 22-25
	<b>Operating Sounds</b> ..... 26
	<b>Troubleshooting</b> ..... 27-29
	<b>Warranty &amp; Service</b> ..... 31
	<b>Guide d'utilisation et d'entretien</b> ..... 32
	<b>Guía de Uso y Cuidado</b> ..... 64



# Important Safety Instructions

**Installer:** Please leave this guide with this appliance.

**Consumer:** Please read and keep this Use and Care Guide for future reference; it provides the proper use and maintenance information.

Keep sales receipt and/or canceled check as proof of purchase.

Call: 1-800-688-9900 U.S.A.  
1-800-688-2002 Canada  
1-800-688-2080 (U.S. TTY for hearing or speech impaired)  
(Mon.-Fri., 8 am-8 pm Eastern Time)

Have complete model and serial number identification of your refrigerator. This is located on a data plate inside the fresh food compartment, on the upper right side. Record these numbers below for easy access.

Model Number \_\_\_\_\_

Serial Number \_\_\_\_\_

Date of Purchase \_\_\_\_\_

In our continuing effort to improve the quality and performance of our appliances, it may be necessary to make changes to the appliance without revising this guide.

## What You Need to Know About Safety Instructions

Warning and Important Safety Instructions appearing in this guide are not meant to cover all possible conditions and situations that may occur. Common sense, caution and care must be exercised when installing, maintaining or operating appliance.

Always contact your dealer, distributor, service agent or manufacturer about problems or conditions you do not understand.

## Recognize Safety Symbols, Words, Labels

### DANGER

**DANGER** – Immediate hazards which **WILL** result in severe personal injury or death.

### WARNING

**WARNING** – Hazards or unsafe practices which **COULD** result in severe personal injury or death.

### CAUTION

**CAUTION** – Hazards or unsafe practices which **COULD** result in minor personal injury or property damage.

### DANGER

**To reduce risk of injury or death, follow basic precautions, including the following:**

**IMPORTANT:** Child entrapment and suffocation are not problems of the past. Junked or abandoned refrigerators are still dangerous – even if they sit out for “just a few days.” If you are getting rid of your old refrigerator, please follow the instructions below to help prevent accidents.

Before you throw away your old refrigerator or freezer:

- Take off the doors.
- Leave the shelves in place so children may not easily climb inside.

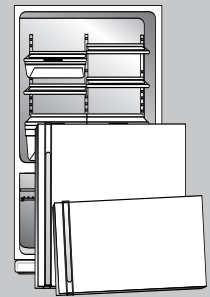

This appliance is equipped with a three-prong grounding plug for your protection against possible electrical shock hazards. It must be plugged into a grounding receptacle. Where a standard two-prong wall receptacle is encountered, it is the personal responsibility and obligation of the customer to have it replaced with a properly grounded three-prong wall receptacle. Do not under any circumstances, cut or remove the third (ground) prong from the power cord. Do not use an adapter plug.

Power supply cord with three-prong grounding plug

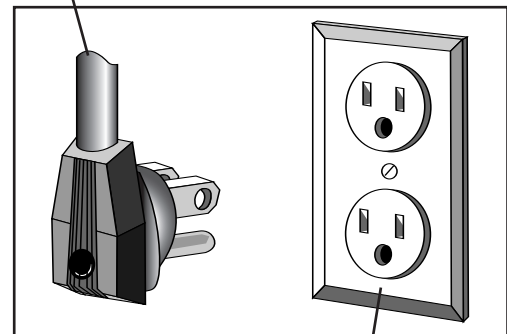

Grounding type wall receptacle



# Important Safety Instructions

## WARNING

**To reduce risk of fire, electric shock, serious injury or death when using your refrigerator, follow these basic precautions, including the following:**

1. Read all instructions before using the refrigerator.
2. Observe all local codes and ordinances.
3. Be sure to follow grounding instructions.
4. Check with a qualified electrician if you are not sure this appliance is properly grounded.
5. Do not ground to a gas line.
6. Do not ground to a cold-water pipe.
7. Refrigerator is designed to operate on a separate 115 volt, 15 amp., 60 cycle line.
8. Do not modify plug on power cord. If plug does not fit electrical outlet, have proper outlet installed by a qualified electrician.
9. Do not use a two-prong adapter, extension cord or power strip.
10. Do not remove warning tag from power cord.
11. Do not tamper with refrigerator controls.
12. Do not service or replace any part of refrigerator unless specifically recommended in Use & Care Guide or published user-repair instructions. Do not attempt service if instructions are not understood or if they are beyond personal skill level.
13. Always disconnect refrigerator from electrical supply before attempting any service. Disconnect power cord by grasping the plug, not the cord.
14. Install refrigerator according to Installation Instructions. All connections for water, electrical power and grounding must comply with local codes and be made by licensed personnel when required.
15. Keep your refrigerator in good condition. Bumping or dropping refrigerator can damage refrigerator or cause refrigerator to malfunction or leak. If damage occurs, have refrigerator checked by qualified service technician.
16. Replace worn power cords and/or loose plugs.
17. Always read and follow manufacturer's storage and ideal environment instructions for items being stored in refrigerator.
18. Your refrigerator should not be operated in the presence of explosive fumes.
19. Children should not climb, hang or stand on any part of the refrigerator.
20. Clean up spills or water leakage associated with water installation.

**SAVE THESE INSTRUCTIONS**



# Installation

Your refrigerator was packed carefully for shipment. Remove and discard shelf packaging and tape. Do not remove the serial plate.

## Location

- Do not install refrigerator near oven, radiator or other heat source. If not possible, shield refrigerator with cabinet material.
- Do not install where temperature falls below 55° F (13° C) or rises above 110° F (43° C). Malfunction may occur at this temperature.
- **Refrigerator is designed for indoor household application only.**

## Measuring the Opening

When installing your refrigerator, measure carefully. Allow 1/2" space at top and 1/2" space behind the machine compartment cover (located in the rear) for proper air circulation.

Subflooring or floor coverings (i.e. carpet, tile, wood floors, rugs) may make your opening smaller than anticipated.

Some clearance may be gained by using the leveling procedure under *Leveling*.

**Important:** If refrigerator is to be installed into a recess where the top of the refrigerator is completely covered, use distance from floor to top of hinge cap to verify proper clearance.

## Transporting Your Refrigerator

- **NEVER** transport refrigerator on its side. If an upright position is not possible, lay refrigerator on its back. Allow refrigerator to sit upright for approximately 30 minutes before plugging it in to assure oil returns to the compressor. Plugging the refrigerator in immediately may cause damage to internal parts.
- Use an appliance dolly when moving refrigerator. **ALWAYS** truck refrigerator from its side or back—**NEVER** from its front.
- Protect outside finish of refrigerator during transport by wrapping cabinet in blankets or inserting padding between the refrigerator and dolly.
- Secure refrigerator to dolly firmly with straps or bungee cords. Thread straps through handles when possible. Do not overtighten. Overtightening restraints may dent or damage outside finish.

## Leveling

### ⚠ CAUTION

To protect property and refrigerator from damage, observe the following:

- Protect vinyl or other flooring with cardboard, rugs, or other protective material.
- Do not use power tools when performing leveling procedure.

To enhance the appearance and maintain performance, the refrigerator should be level.

### Note

- Complete any required door reversal, panel installation and/or a water supply connection, before leveling.

### Materials Needed:

- 3/8" hex head driver
- Carpenter's level

#### 1. Remove toe grille.

- Grasp firmly and pull outward to unclip.

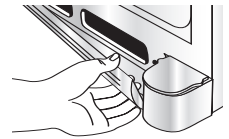

#### 2. Remove bottom hinge cover(s).

- Place the eraser end of a pencil or similar blunt tool in the cover notch.

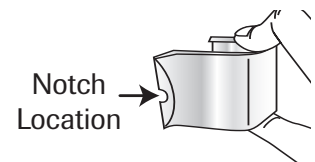
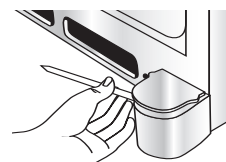

- Use slight pressure to pry the cover loose.
- Continue to maintain downward pressure to the notched side of the cover while swinging it off.

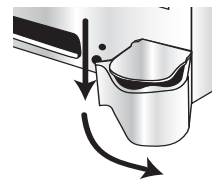

#### 3. Using hex head driver, turn the front adjustment screws (A) on each side to raise or lower the front of the refrigerator.





# Installation

## Note

- Some models only have adjustment screws "A."

- Using the hex head driver, turn each of these adjustment screws (B) to raise or lower the rear of the refrigerator.
- Using the carpenter's level, make sure front of refrigerator is  $\frac{1}{4}$ " (6 mm) or  $\frac{1}{2}$ " bubble higher than back of refrigerator and that the refrigerator is level from side to side.
- Turn stabilizing legs (C) clockwise until firmly against floor.
- Turn adjustment screws (A) counterclockwise to allow the full weight of the refrigerator to rest on the stabilizing legs.
- Replace hinge cover(s).
  - Position cover into the outer edge of the hinge.
  - Swing the cover toward the cabinet and snap it into place.
- Replace the toe grille.

## Note

- For proper reinstallation, ensure the "top" marking on the interior of the toe grille is oriented correctly.
- Align the toe grille mounting clips with the lower cabinet slots.
- Push the toe grille firmly until it snaps into place.

## Door and Drawer Removal

Some installations require door/drawer removal to transport the refrigerator to its final location.

## ⚠ WARNING

To avoid electrical shock which can cause severe personal injury or death, observe the following:

- Disconnect power to refrigerator before removing doors or drawer. Connect power only after replacing doors or drawer.

## ⚠ CAUTION

To avoid damage to walls and flooring, protect vinyl or other flooring with cardboard, rugs or other protective material.

- Unplug power cord from power source.
- Remove toe grille and bottom hinge cover(s) (see page 3).

- Remove top hinge cover from refrigerator door by removing Phillips screw and retain screw and cover for later use.

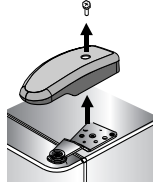

- Unscrew  $\frac{5}{16}$ " hex head screws from top hinge to remove hinge and retain all screws for later use.

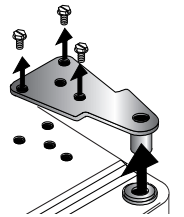

- Lift right side refrigerator door from center hinge pin. Remove door closure from center hinge pin on the right side and retain for later use.

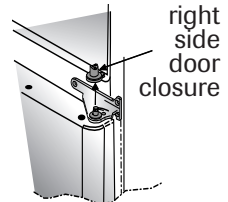

- Disconnect wire harness on top of left side refrigerator door top hinge.

Release two-pin connector by pressing junction point with a flat blade screwdriver or fingernail.

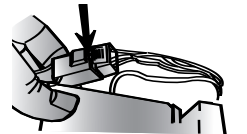

Green ground wire remains attached to the hinge.

- Unscrew  $\frac{5}{16}$ " hex head screws from top hinge to remove hinge and retain for later use.

Lift left side refrigerator door, along with top hinge, from center hinge pin.

Remove center hinge pin with a  $\frac{5}{16}$ " hex head driver and retain hinge pin for later use.

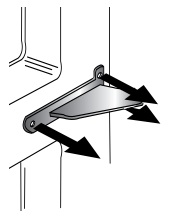

- Remove Phillips screws to remove right and left hinges and retain all screws for later use.

- Remove both stabilizing brackets with  $\frac{3}{8}$ " hex head driver and retain screws for later use.

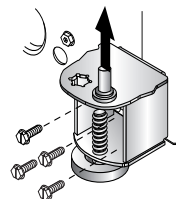



# Installation

## Pullout Freezer Drawer (select models)

### ⚠ DANGER

To prevent accidental child entrapment or suffocation risk, do not remove the divider in the top freezer basket.

### ⚠ WARNING

To avoid electrical shock which can cause severe personal injury or death, disconnect power to refrigerator before removing doors. After replacing doors, connect power.

### ⚠ CAUTION

To avoid possible injury, product, or property damage, you will need two people to perform the following instructions.

#### To Remove:

1. Pull drawer open to full extension.
2. Tilt the lower basket forward and lift to remove.
3. On each white drawer bracket is a basket cradle with two snap attachments. To release each cradle, unlatch the snaps by pushing them inward, away from the side bracket. Lift the cradles off of the rails.
4. Remove Phillips screw from each of the drawer slides (select models).
5. Lift top of drawer front to unhook the drawer from the slides. Lift door front out to remove.

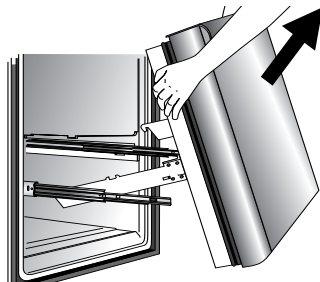
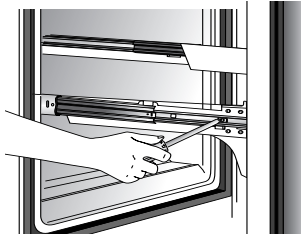
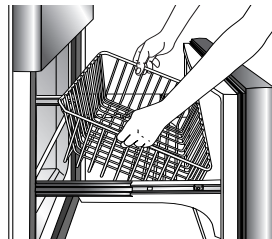

#### To Install:

1. Pull both rails out to full extension.
2. While supporting door front, hook supports into slots located on inside of each slide.

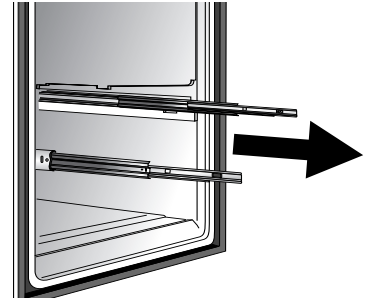

#### Note

- All four drawer bracket supports must be in the proper slots for the drawer to function properly.

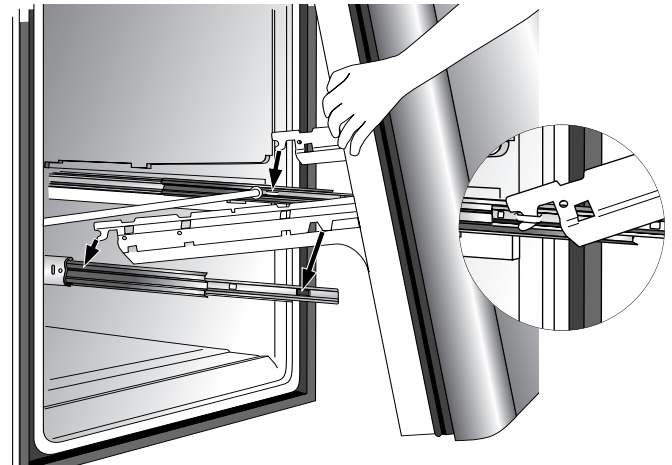

3. Lower door front into final position.
4. Replace and tighten Phillips screws that were removed from the drawer slides (select models).
5. Place the basket cradles back onto the drawer slides. Align basket cradle snaps with the slots on the drawer brackets and press each cradle towards the bracket until it clicks.

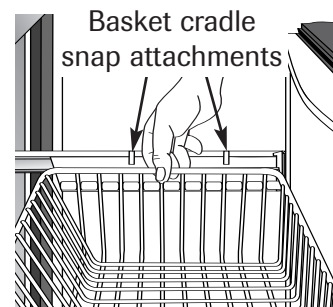

6. Tilt the lower basket front down and set it down into the basket cradles.



# Installation

## Door Reinstallation

1. Install hinge assemblies:
  - Install center hinge with Phillips screws.
2. Place hinge side of refrigerator door on center hinge pin.
  - Install top hinge with  $\frac{5}{16}$ " hex head screws.
3. While holding refrigerator door upright, tighten down top hinge with  $\frac{5}{16}$ " hex head driver.
4. Reconnect two-pin connector.
5. Replace top hinge covers.

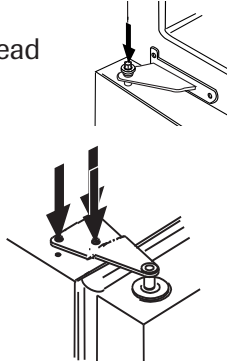

## Handles

If not installed, the handle is located in the interior of the fresh food section or attached to the back of your refrigerator.

Remove and discard handle packaging and tape.

### Front Mount Handle

#### Materials Needed:

- Gloves to protect hands
- Phillips screwdriver
- Plastic door removal card (or  $\frac{1}{32}$ " thick plastic card), retain the card

#### Attach Extensions to Handle:

1. Align handle and extension as shown.
2. Place extension in handle opening.
3. Apply slight pressure to both sides of the extension piece.
4. Slide extension until it stops on inside edge of handle.

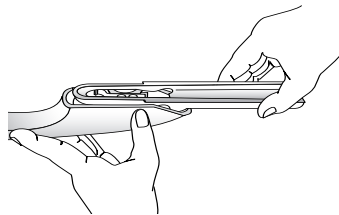

#### To Install:

1. The handles are to be oriented as shown.
2. Align front mount door handle clip with the door tabs.

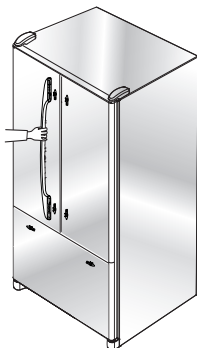

3. Ensure the handle clips are positioned slightly above the door tabs.

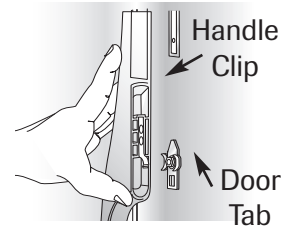

4. Rotate the handle so that the handle is flat against the door.

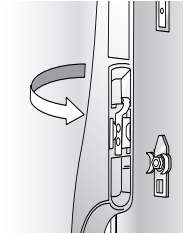

5. Push the handle down against the upper door tab just enough to allow it to hang unsupported.

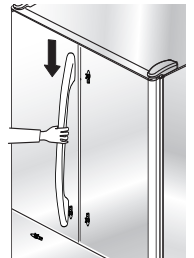

6. Align bottom of handle with lower door tab. Press upper handle end to door surface and firmly grasp lower end of handle. Gently slide handle upward until bottom of handle settles on door surface, then reverse direction, sliding downward to almost engaging tab with clip.

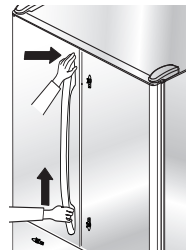

7. Grasp the handle firmly and slide down until it clicks. The audible click indicates fastening clips are securely interlocked.

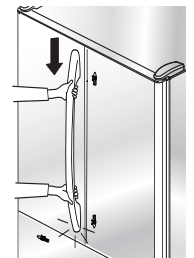

#### To Remove:

1. Flex the handle away from the door panel. Simultaneously place door handle removal card underneath the base of the lower handle. Insert the card to the line or until it stops.
2. Grasp the lower part of the handle firmly and lift to remove.

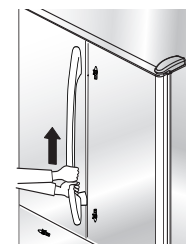
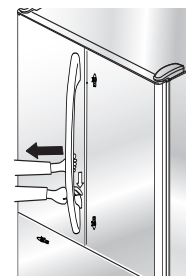



# Installation

## Freezer Handle

### Materials Needed:

- Gloves to protect hands.
- Phillips screwdriver.
- Plastic handle removal card (or 1/32" thick plastic card). Retain the card.

### Notes

- There is a slight curve to the freezer handle.
- For proper installation, be sure handle is oriented as shown.

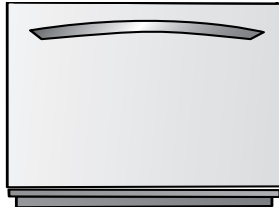

### To Install:

1. Align door handle clips slightly to the left of the tabs attached to the freezer door.
2. Rotate the handle so the left base is flat against the door.

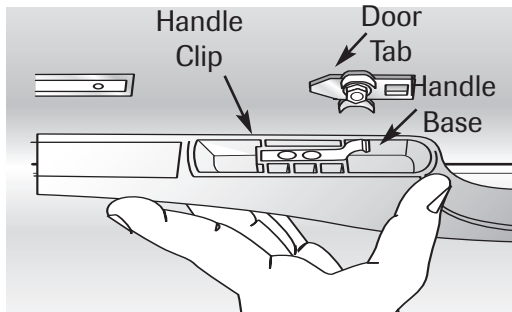

3. Push the left handle base against the left door tab and slightly to the right, just enough to allow it to hang unsupported.
4. While firmly supporting the left handle base against the door, align the right base of the handle with the right tabs that are attached to the door.
5. Now, while firmly holding the handle at the left and right bases, gently slide the handle towards the right until the right base settles in. The handle should now be flat against the face of the freezer door at both the left and right bases.
6. With hands still firmly keeping the handle flat against the freezer door, you may have to reverse directions momentarily to assure clip/tab

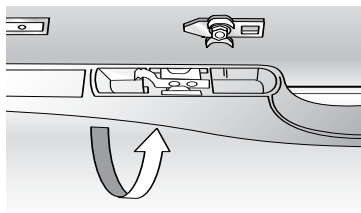

engagement. Then firmly slide the handle to the right until it clicks. The audible “click” indicates that the fastening clips are securely interlocked.

### To Remove:

1. At the right end, flex the handle base away from the surface of the freezer drawer. Simultaneously slide the door handle removal card that came with your refrigerator under the right side base of the handle. Slide the card to the line indication or until it stops, which will be approximately 1 1/2”.
2. With both hands, firmly grasp the handle towards the right base.
3. Slide towards the left, lift and remove from the surface.

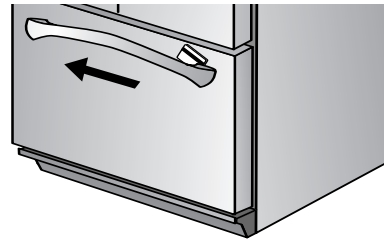

## Installing Front-Mounted Handles for Stainless Steel Doors

1. Loosen lower door clip on door with a phillips screwdriver.
2. Locate predrilled hole at base of handle, and fit hollow end of handle over lower door clip.
3. Fit other end of handle over upper door clip and slide up as far as possible.

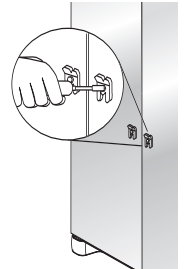

**NOTE:** If top of handle does not fit over top clip, loosen lower clip further until fit can be accomplished.

4. Insert phillips screwdriver into predrilled hole at base of handle to tighten screw. Insert plastic button plug into hole.
5. Repeat above steps to install other handle.

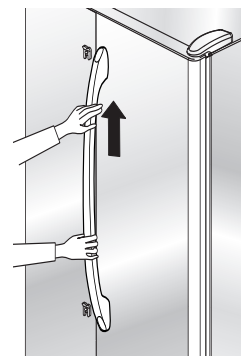
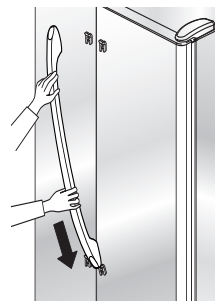





# Installation

## Removing Front-Mounted Handles for Stainless Steel Doors

1. Remove plastic button plug at base of handle with a very small flat-blade screwdriver.

- Insert phillips screwdriver into predrilled hole to remove screw.

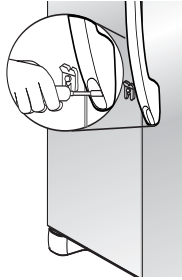

2. Slide handle down and remove from door clip.

3. Repeat above steps to remove other handle.

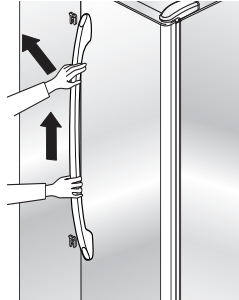

## Installing Front-Mounted Handles for Stainless Steel Freezer Door

1. Loosen lower door clip on door with a phillips screwdriver

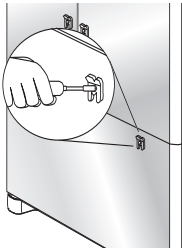

2. Locate predrilled hole at base of handle, and fit hollow end of handle over left door clip.

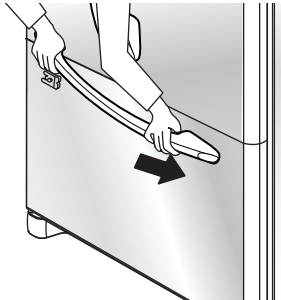

3. Fit other end of handle over left door clip and slide left as far as possible.

**NOTE:** If end of handle does not fit over left clip, loosen right clip further until fit can be accomplished.

4. Insert phillips screwdriver into predrilled hole at end of handle to tighten screw. Insert plastic button plug into hole.



## Removing Front-Mounted Handles for Stainless Steel Freezer Door

1. Remove right side plastic button plugs at each end of handle with a very small flat-blade screwdriver.

- Insert phillips screwdriver into predrilled hole to remove screw.

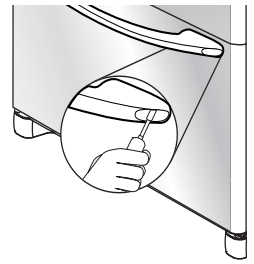

2. Slide handle right and remove from door clip.

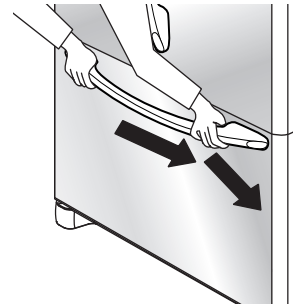

## Connecting the Water Supply

### ⚠ WARNING

To reduce the risk of injury or death, follow basic precautions, including the following:

- Read all instructions before installing ice maker.
- Do not attempt installation if instructions are not understood or if they are beyond personal skill level.
- Observe all local codes and ordinances.
- Do not service ice maker unless specifically recommended in Use & Care Guide or published user-repair instructions.
- Disconnect power to refrigerator before installing ice maker.
- Water damage due to an improper water connection may cause mold/mildew growth. Clean up spills or leakage immediately!

cont.



# Installation

## ⚠ CAUTION

To avoid property damage or possible injury, follow basic precautions, including the following:

- Consult a plumber to connect  $\frac{1}{4}$ " O.D. copper tubing to household plumbing to assure compliance with local codes and ordinances.
- Confirm water pressure to water valve is between 35 and 100 pounds per square inch, 20 pounds per square inch without filter.
- Do not use a self-piercing, or  $\frac{3}{16}$ " saddle valve. Both reduce water flow and can become clogged over time, and may cause leaks if repair is attempted.
- Tighten nuts by hand to prevent cross threading. Finish tightening nuts with pliers and wrenches. Do not overtighten.
- Wait two to three hours before placing refrigerator into final position to check and correct any water leaks. Recheck for leaks after 24 hours.
- Verify the copper tubing under the sleeve is smooth and free from defects. Do not reuse an old sleeve.

### Materials Needed:

- $\frac{1}{4}$ " outer diameter flexible copper tubing
- Shut-off valve (requires a  $\frac{1}{4}$ " hole to be drilled into water supply line before valve attachment)
- Adjustable wrench
- $\frac{1}{4}$ " hex nut driver

### Notes

- Use copper tubing only for installation. Plastic is less durable and can cause damage.
- Add 8' to tubing length needed to reach water supply for creation of service loop.

1. Create service loop with copper tubing (minimum 2' diameter). Avoid kinks in the copper tubing when bending it into a service loop. Do not use plastic tubing.

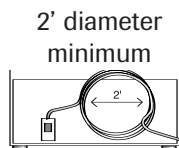

2. Remove plastic cap from water valve inlet port.
3. Place brass nut (A) and sleeve (B) on copper tube end as illustrated.

**Reminder:** Do not use an old sleeve. The nut and sleeve are provided in the use and care packet.

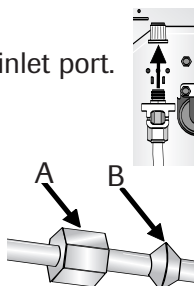

4. Place end of copper tubing into water valve inlet port. Shape tubing slightly. Do not kink – so that tubing feeds straight into inlet port.

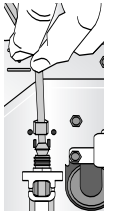

5. Slide brass nut over sleeve and screw nut into inlet port. Tighten nut with wrench.

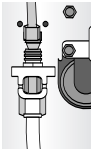

**IMPORTANT:** Do not overtighten. Cross threading may occur.

6. Pull on tubing to confirm connection is secure. Connect tubing to frame with water tubing clamp (C) and turn on water supply. Check for leaks and correct if necessary. Continue to observe the water supply connection for two to three hours prior to moving the refrigerator to its permanent location.

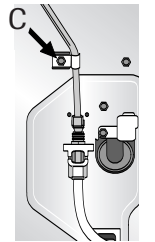

7. Monitor water connection for 24 hours. Correct leaks, if necessary.

## Opening and Closing Your Fresh Food Doors

Your new refrigerator is uniquely designed with two fresh food doors. Either door can be opened or closed independently of one another.

There is a vertically-hinged section on the left fresh food door. When the left door is closed, the hinged section automatically forms a seal between the two doors when both doors are closed.

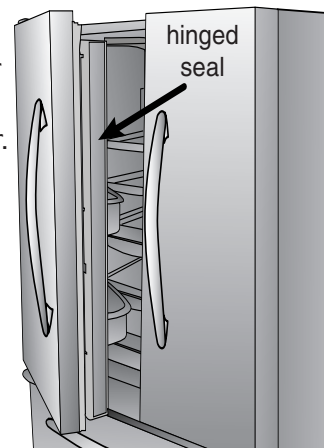

When the left door is opened, the hinged seal automatically folds inward so that it is out of the way.

## ⚠ WARNING

To avoid electrical shock which can cause severe personal injury or death, **DO NOT** attempt to remove the hinged seal from the fresh food section.

## ⚠ CAUTION

To avoid possible product damage, **ALWAYS** verify that the hinged seal is folded against the edge of the door prior to closing.



# Temperature Controls

## Touch Temperature Controls

The controls are located at the top front of the refrigerator compartment.

### Control



## Initial Control Settings

After plugging the refrigerator in, set the controls.

- Pressing the or pads adjusts the controls to the desired setting.
- The temperature control range for both compartments is 1 through 7 (coldest).
- Initially set the refrigerator control on 4.
- Initially set the freezer control on 4.
- Let the refrigerator run at least 8 to 12 hours before adding food.

## Warm Cabinet Surfaces

At times, the front of the refrigerator cabinet may be warm to the touch. This is a normal occurrence that helps prevent moisture from condensing on the cabinet. This condition will be more noticeable when you first start the refrigerator, during hot weather and after excessive or lengthy door openings.

## Adjusting the Controls

- 24 hours after adding food, you may decide that one or both compartments should be colder or warmer. If so, adjust the control(s) as indicated in the *Temperature Control Guide* table below. See page 19 for instructions on checking compartment temperature.
- Except when starting the refrigerator, do not change either control more than one number at a time.
- Allow 24 hours for temperatures to stabilize.
- Changing either control will have some effect on the temperature of the other compartment.

### Temperature Control Guide

<b>Refrigerator too warm</b>	Set the refrigerator control to next higher number by pressing the  pad.
<b>Refrigerator too cold</b>	Set the refrigerator control to next lower number by pressing the  pad.
<b>Freezer too warm</b>	Set the freezer control to next higher number by pressing the  pad.
<b>Freezer too cold</b>	Set the freezer control to next lower number by pressing the  pad.
<b>Turn refrigerator OFF</b>	Press the refrigerator or freezer  pad until a dash (-) appears in the display.

## Energy Saver Switch (select models)

- **Off** - The refrigerator uses more energy when this switch is off, because a heater located in the hinged seal section of the door is running. This heater helps prevent condensation formation on the exterior of the hinged seal. Turn the energy saver switch OFF when the environment is warm and more humid or if moisture is noticed on the door exterior.
- **On** - This setting saves energy by not using the heater. Turn the energy saver switch ON when the environment is less humid.



# Temperature Controls

## Triple Cool Climate Control (select models)

The control is located at the top front of the fresh food compartment.

### Control

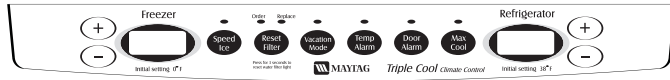

### Initial Temperature Setting

Temperatures are preset at the factory at 38° F (3° C) in the fresh food compartment and 0° F (-18° C) in the freezer compartment.

### Adjusting the Control

24 hours after adding food, you may decide that one or both compartments should be colder or warmer. If so, adjust the control as indicated in the Temperature Control Guide below.

- The first touch of the (+) or (-) pads shows the current temperature setting.
- The display will show the new setting for approximately three seconds, and then return to the actual temperature currently within that compartment.
- Do not change either control more than one degree at a time. Allow temperature to stabilize for 24 hours before making a new temperature adjustment.

### Temperature Control Guide

<b>Refrigerator too cold</b>	Set the refrigerator control to next higher number by pressing the (+) pad.
<b>Refrigerator too warm</b>	Set the refrigerator control to next lower number by pressing the (-) pad.
<b>Freezer too cold</b>	Set the freezer control to next higher number by pressing the (+) pad.
<b>Freezer too warm</b>	Set the freezer control to next lower number by pressing the (-) pad.
<b>Turn refrigerator OFF</b>	Press the freezer (+) pad until OFF appears in the display. Press either the freezer or refrigerator (-) pad to turn back on.

### Speed Ice



When activated, Speed Ice reduces the freezer temperature to the optimum setting for 24 hours in order to produce more ice. **Note:** When the Speed Ice feature is in operation, the (+) and (-) pads for the freezer control will not operate.

### Reset Filter (select models)



When a water filter has been installed in the refrigerator, the yellow **Order** light will illuminate when 90 percent of the volume of water for which the filter is rated has passed through the filter OR 11 months have elapsed since the filter has been installed.

The red **Replace** light will illuminate when the rated volume of water has passed through the filter OR 12 months have elapsed since the filter was installed. A new filter should be installed immediately when the **Replace** light is illuminated.

After replacing the filter, press and hold the **Reset Filter** pad for three seconds. The Order and Replace lights will go off.

### Vacation Mode



The Vacation Mode feature causes the freezer to defrost less frequently, conserving energy. The Vacation Mode indicator light will illuminate when the feature is activated. To deactivate, press the Vacation Mode pad again OR open either door. The indicator light will go off.

### Notes

- Door openings will not deactivate Vacation Mode for approximately one hour after activation.
- If vacationing for more than a few days, see the Preparing for Vacation section, page 25.

### Temp Alarm



The Temp Alarm system will alert you if the freezer or fresh food temperatures exceed normal operating temperatures due to a power outage or other event. When activated, the Temp Alarm light will illuminate.



# Temperature Controls

If the freezer or fresh food temperatures have exceeded these limits, the display will alternately show the current compartment temperatures and the highest compartment temperatures reached when the power was out. An audible alarm will sound repeatedly.

Press the Temp Alarm pad once to stop the audible alarm. The Temp Alarm light will continue to flash and the temperatures will alternate until the temperatures have stabilized.

To turn off Temp Alarm, press and hold the Temp Alarm pad for three seconds. The indicator light will go off.

## Door Alarm



The Door Alarm will alert you when one of the doors has been left open for five continuous minutes. When this happens, an audible alarm will sound every few seconds until the door is closed OR the Door Alarm pad is pressed to deactivate the feature.

## Max Cool



When activated, Max Cool causes the fresh food and freezer temperatures to drop to the minimum settings on the control. This cools down the refrigerator and freezer after extended door openings or when loading the refrigerator or freezer with warm food. **Note:** When the Max Cool feature is in operation, the (+) and (-) pads for the refrigerator and freezer controls will not operate.

To activate, press the Max Cool pad. Max Cool will deactivate automatically after 12 hours, OR press the Max Cool pad to deactivate the feature.

## User Preferences

Access the User Preferences menu to:

- Activate or turn off Super Cool (select models)
- Change the temperature display from °F to °C
- Enable or disable audible alarms.
- Adjust the light level at which the Dispenser Auto Light will illuminate (when this feature is activated on the ice and water dispenser) (select models)
- Activate the Sabbath Mode

To access the User Preferences menu, press and hold the Door Alarm pad for three seconds. When in the User Preferences mode, a short title for the feature will appear in the Freezer temperature display and the feature status will appear in the Fresh Food display.

1. Use the Freezer up and down control to scroll through the features.
2. When the desired feature is displayed, use the Fresh Food up and down control to change the status.
3. When changes are complete, press the Door Alarm pad for three seconds OR close the Fresh Food door.

## Super Cool (CC) (select models)

When Super Cool is ON, an air-mixing fan in the fresh food compartment is activated to improve air flow and temperature control. To save energy, this feature may be deactivated by choosing OFF.

## Temperature Display (F\_C)

Change the display to show temperatures in degrees Fahrenheit or degrees Celsius.

## Alarm (AL)

When the Alarm mode is OFF, all audible alarms will be disabled until the feature is turned on.

## Auto Light Level Selection (LL) (select models)

This setting adjusts the light level at which the dispenser light will illuminate when the sensor detects that the light levels in the room are low. Setting 1 is the darkest light level setting, setting 9 is the lightest light level setting. **Note:** The Auto Light (select models) must be activated on the ice and water dispenser control to take advantage of this option.

## Sabbath Mode (SAB)

When the Sabbath Mode is ON, all control lights and the night light will be disabled until the feature is turned OFF. This feature does not disable the interior lights. Press any pad to restore the control lights.

## Warm Cabinet Surfaces

At times, the front of the refrigerator cabinet may be warm to the touch. This is a normal occurrence that helps prevent moisture from condensing on the cabinet. This condition will be more noticeable when the refrigerator is first started, during hot weather and after excessive or lengthy door openings.



# Fresh Food Features

## Shelves

### ⚠ CAUTION

To avoid personal injury or property damage, observe the following:

- Never attempt to adjust a shelf that is loaded with food.
- Confirm shelf is secure before placing items on shelf.
- Handle tempered glass shelves carefully. Shelves may break suddenly if nicked, scratched, or exposed to sudden temperature change.

Your refrigerator has **Spill-Catcher™ Glass Shelves**. The shelves have a spill retainer edge which allows for easier clean up and some are equipped with a slide out feature. To slide out, grasp the front of the shelf and pull forward. Push in the shelf to return to the original position.

### To Remove a Shelf:

- Slightly tilt up the front and lift up the rear of the shelf, then pull the shelf straight out.

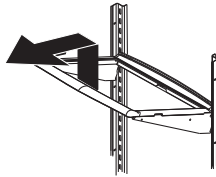

### To Lock the Shelf Into Another Position:

- Tilt up the front edge of the shelf.
- Insert the hook into the desired frame openings and let the shelf settle into place.
- Be sure the shelf is securely locked at the rear.

## Elevator™ Shelf (select models)

The **Elevator™ Shelf** is equipped with a spill-retaining edge and the EasyGlide™ slide-out feature. It can be adjusted up or down without unloading.

### To Slide Out Elevator™ Shelf:

- Grasp the front of the shelf and pull forward.
- Push the shelf in to return to original position.

### To Adjust the Elevator™ Shelf:

- Pull out the knob on the crank handle.
- Rotate the crank clockwise to raise the shelf, and counterclockwise to lower the height of the shelf.

### To Remove Elevator™ Shelf:

- Completely unload the shelf and pull the shelf forward.
- Pull until the shelf stops.
- Press up on the tabs located underneath its outside edges and continue pulling forward until the shelf is clear of the frame.

### To Replace Elevator™ Shelf:

- Align the shelf to the frame and push it all the way back. It is not necessary to press up on the tabs for reinstallation.

In ordinary use, the Elevator™ Shelf frame assembly does NOT require removal. Though unlikely, and not recommended, the correct removal procedure is as follows:

### To Remove Frame Assembly:

- Unload the shelf completely.
- Slide the shelf forward about 2" and manually move the two rear latches toward the shelf center.
- While supporting the entire shelf and frame from underneath, lift slightly and rotate the assembly approximately 30° to allow the rear mechanism to clear the vertical rear side rails.
- The entire assembly can then be moved forward and clear of the refrigerator compartment.

### To Reinstall Frame Assembly:

- Reverse the removal procedure. Be sure the shelf is in a level position. When the sliding shelf is pushed to the rear, it will reposition the rear latches to their correct operating position.

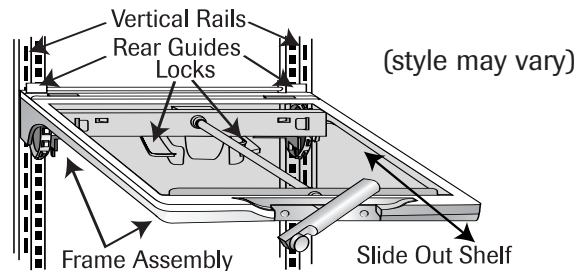



# Water Filter (select models)

## Water Filter Removal and Installation

### ⚠ WARNING

To avoid serious illness or death, do not use refrigerator where water is unsafe or of unknown quality without adequate disinfection before or after use of filter.

### ⚠ CAUTION

**After installing a new water filter, always dispense water for two minutes before removing the filter for any reason. Air trapped in system may cause water and cartridge to eject. Use caution when removing.**

- The bypass cap does not filter water. Be sure to have replacement cartridge available when filter change is required.
- If water filtration system has been allowed to freeze, replace filter cartridge.
- If system has not been used for several months, or water has an unpleasant taste or odor, flush system by dispensing water for two to three minutes. If unpleasant taste or odor persists, change filter cartridge.

## Initial Installation

The water filter is located in the upper right-hand corner of the fresh food compartment.

1. Remove blue bypass cap and retain for later use.
  2. Remove sealing label from end of filter and insert into filter head.
  3. Rotate gently clockwise until filter stops. Snap filter cover closed.
  4. Reduce water spurts by flushing air from system. Run water continuously for two minutes through dispenser until water runs steady. During initial use, allow about a one- to two-minute delay in water dispersal to allow internal water tank to fill.
- Additional flushing may be required in some households where water is of poor quality.

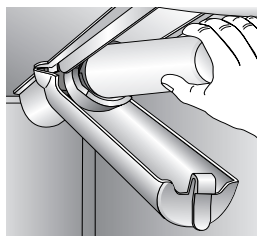
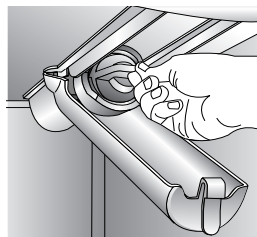

## Replacing Water Filter

**IMPORTANT: Air trapped in system may cause water and cartridge to eject. Always dispense water for at least 2 minutes before removing the filter for any reason. Use caution when removing.**

1. Turn filter counterclockwise until it releases from filter head.
2. Drain water from filter into sink, and dispose in normal household trash.
3. Wipe up excess water in filter cover and continue with *Initial Installation*, steps 2 through 4.

The filter should be changed at least every 12 months.

**IMPORTANT:** Condition of water and amount used determines life span of water filter cartridge. If water use is high, or if water is of poor quality, replacement may need to take place more often.

To purchase a replacement water filter cartridge, contact your dealer or call 1-877-232-6771 U.S.A. or 1-800-688-8408 Canada.

The dispenser feature may be used without a water filter cartridge. If you choose this option, replace filter with blue bypass cap.

State of California  
Department of Health Services

### Water Treatment Device Certificate Number

03 - 1583

Date Issued: September 16, 2003  
Date Revised: April 22, 2004

Trademark/Model Designation	Replacement Elements
-----------------------------	----------------------

UKF8001AXX750	UKF8001AXX
469006-750	46 9006
67003523-750	67003523

Manufacturer: PentaPure Inc.

The water treatment device(s) listed on this certificate have met the testing requirements pursuant to Section 116830 of the Health and Safety Code for the following health related contaminants:

**Microbiological Contaminants and Turbidity**

Cysts  
Turbidity

**Inorganic/Radiological Contaminants**

Asbestos  
Lead  
Mercury

**Organic Contaminants**

Atrazine  
Lindane  
Benzene  
Carbofuran  
p-dichlorobenzene  
Toxaphene

Rated Service Capacity: 750 gal.

Rated Service Flow: 0.78 gpm

**Conditions of Certification:**

Do not use where water is microbiologically unsafe or with water of unknown quality, except that systems certified for cyst reduction may be used on disinfected waters that may contain filterable cysts.



# Water Filter (select models)

## PuriClean® II System Specification and Performance Data Sheet Refrigerator Water Filter Cartridge Model UKF8001AXX

### Specifications

Service Flow Rate (Maximum).....0.78 GPM (2.9 L/min)  
 Rated Service Life UKF8001AXX-750 (Maximum).....750 gallons/2838 liters  
 Maximum Operating Temperature .....100° F/38° C  
 Minimum Pressure Requirement.....35 psi/241 kPA  
 Minimum Operating Temperature.....33° F/1° C  
 Maximum Operating Pressure.....120 psi/827 kPA



1000 Apollo Road  
 Eagan, Minnesota 55121-2240  
 651.450.4913  
 EPA EST #35917-MN-1

100834/B

### Performance Data

Standard No. 42: Aesthetic Effects								
Parameter	USEPA MCL	Influent Challenge Concentration	Influent Average	Effluent		% Reduction		Min. Required Reduction
				Average	Maximum	Average	Minimum	
Chlorine	–	2.0 mg/L ± 10%	1.88 mg/L	<0.05136364 mg/L	0.06 mg/L	>97.26%	96.84%	50%
T & O	–	–	–	–	–	–	–	–
Particulate**	–	at least 10,000 particles/ml	5,700,000 #/ml	30,583 #/ml	69,000 #/ml	99.52%	98.94%	85%

Standard No. 53: Health Effects								
Parameter	USEPA MCL	Influent Challenge Concentration	Influent Average	Effluent		% Reduction		Min. Required Reduction
				Average	Maximum	Average	Minimum	
Turbidity	1 NTU**	11 ± 1 NTU***	10.7 NTU	0.31 NTU	.049 NTU	97.09%	95.20%	0.5 NTU
Cysts	99.5% Reduction	Minimum 50,000/L	166,500 #/L	<1 #/L	<1 #/L	>99.99%	>99.99%	>99.95%
Asbestos	99% Reduction	10 <sup>7</sup> 10 <sup>6</sup> fibers/L; fibers >10 micrometers in length	155 MF/L	<1 MF/L	<1 MF/L	>99.99%	>99.99%	99%
Lead at pH 6.5	0.015 mg/L	0.15 mg/L + 10%	0.153 mg/L	<.001 mg/L	<.001 mg/L	>99.35%	>99.29%	0.10 mg/L
Lead at pH 8.5	0.015 mg/L	0.15 mg/L + 10%	0.150 mg/L	<.001 mg/L	<.001 mg/L	>99.33%	>99.29%	0.10 mg/L
Mercury at pH 6.5	0.002 mg/L	.006 mg/L ± 10%	0.006 mg/L	0.0003 mg/L	0.0005 mg/L	95.70%	90.91%	0.002 mg/L
Mercury at pH 8.5	0.002 mg/L	.006 mg/L ± 10%	0.006 mg/L	0.0008 mg/L	0.0015 mg/L	86.22%	75.93%	0.002 mg/L
Atrazine	0.003 mg/L	0.009 mg/L + 10%	0.009 mg/L	<0.002 mg/L	0.002 mg/L	76.99%	75.31%	0.003 mg/L
Benzene	0.005 mg/L	0.015 mg/L ± 10%	0.014 mg/L	0.0006 mg/L	0.0011 mg/L	95.71%	92.14%	0.005 mg/L
Carbofuran	0.04 mg/L	0.08 mg/L ± 10%	0.081 mg/L	<0.001 mg/L	<0.001 mg/L	98.74%	98.46%	0.04 mg/L
p-Dichlorobenzene	0.075 mg/L	.225 mg/L ± 10%	0.208 mg/L	<0.0005 mg/L	<0.0005 mg/L	99.76%	99.74%	0.075 mg/L
Lindane	0.0002 mg/L	0.002 mg/L + 10%	0.002 mg/L	0.000 mg/L	<0.0001 mg/L	98.72%	96.50%	0.0002 mg/L
Toxaphene	0.003 mg/L	0.015 ± 10%	0.015 mg/L	<0.001 mg/L	<0.001 mg/L	92.97%	91.67%	0.003 mg/L

\* Tested using a flow rate of 0.78 gpm; pressure of 60 psig; pH of 7.5 + 0.5; temp. of 68° + 5° F (20° + 3° C)

\*\* Measurement in Particles/ml. Particles used were 0.5 - 1 microns

\*\*\* NTU - Nephelometric Turbidity Units



Tested and certified by NSF International against ANSI/NSF Standards 42 & 53 in models UKF8001AXX-750 for the reduction of:

#### Standard No. 42: Aesthetic Effects

Taste and Odor Reduction  
 Chlorine Taste & Odor  
 Mechanical Filtration Unit  
 Particulate Reduction Class 1

#### Standard No. 53: Health Effects

Chemical Reduction Unit  
 Lead, Atrazine, Lindane, Benzene, Carbofuran, p-Dichlorobenzene, Mercury & Toxaphene Reduction  
 Mechanical Filtration Unit  
 Cyst, Turbidity and Asbestos Reduction

### General Use Conditions

Read this Performance Data Sheet and compare the capabilities of this unit with your actual water treatment needs.

**DO NOT use this product where water is microbiologically unsafe or of unknown quality without adequate disinfection before or after the system. System certified for cyst reduction may be used on disinfected water that may contain filterable cysts.**

**USE ONLY WITH COLD WATER SUPPLY. CHECK FOR COMPLIANCE WITH THE STATE AND LOCAL LAWS AND REGULATIONS.**

The PuriClean® II retractable water filtration system uses a UKF8001AXX replacement cartridge. Timely replacement of filter cartridge is essential for performance satisfaction from this filtration system. Please refer to the applicable section of your Use & Care Guide for general operation, maintenance requirements and troubleshooting. Suggested retail price of replacement water filter is \$39.99.

This system has been tested according to ANSI/NSF 42 and 53 for reduction of the substance listed above. The concentration of the indicated substances in water entering the system was reduced to a concentration less than or equal to the permissible limit for water leaving the system, as specified in ANSI/NSF 42 and 53.





# Food Storage Tips

## Fresh Food Storage

- The fresh food compartment of a refrigerator should be kept between 34°-40° F (1°-4° C) with an optimum temperature of 37° F (3° C). To check the temperature, place an appliance thermometer in a glass of water and place in the center of the refrigerator. Check after 24 hours. If the temperature is above 40° F (4° C) adjust the controls as explained on pages 10-12.
- Avoid overcrowding the refrigerator shelves. This reduces the circulation of air around the food and results in uneven cooling.

## Fruits and Vegetables

- Storage in the crisper drawers traps humidity to help preserve the fruit and vegetable quality for longer time periods (see page 14).
- Sort fruits and vegetables before storage and use bruised or soft items first. Discard those showing signs of decay.
- Always wrap odorous foods such as onions and cabbage so the odor does not transfer to other foods.
- While vegetables need a certain amount of humidity to remain fresh, too much humidity can shorten storage times (especially leafy vegetables). Drain vegetables well before storing.
- Wait to wash fresh produce until right before use.

## Meat and Cheese

- Raw meat and poultry should be wrapped securely so leakage and contamination of other foods or surfaces does not occur.
- Occasionally mold will develop on the surface of hard cheeses (Swiss, Cheddar, Parmesan). Cut off at least an inch around and below the moldy area. Keep your knife or instrument out of the mold itself. Do not try to save individual cheese slices, soft cheese, cottage cheese, cream, sour cream or yogurt when mold appears.

## Dairy Food

- Most dairy foods such as milk, yogurt, sour cream and cottage cheese have freshness dates on their cartons for appropriate length of storage. Store these foods in the original carton and refrigerate immediately after purchasing and after each use.

## Frozen Food Storage

- The freezer compartment of a refrigerator should be kept at approximately 0° F (-18° C). To check the temperature, place an appliance thermometer between the frozen packages and check after 24 hours. If the temperature is above 0° F (-18° C), adjust the control as described on pages 10-12.
- A freezer operates more efficiently when it is at least two-thirds full.

## Packaging Foods for Freezing

- To minimize dehydration and quality deterioration use aluminum foil, freezer wrap, freezer bags or airtight containers. Force as much air out of the packages as possible and be sure they are tightly sealed. Trapped air can cause the food to dry out, change color and develop an off-flavor (freezer burn).
- Overwrap fresh meats and poultry with suitable freezer wrap prior to freezing.
- Do not refreeze meat that has completely thawed.

## Loading the Freezer

- Avoid adding too much warm food to the freezer at one time. This overloads the freezer, slows the rate of freezing and can raise the temperature of frozen foods.
- Leave space between the packages so cold air can circulate freely, allowing food to freeze as quickly as possible.
- Avoid storing hard-to-freeze foods such as ice cream and orange juice on the freezer door shelves. These foods are best stored in the freezer interior where the temperature varies less with door openings.

Refer to the *Food Storage Chart* on pages 20 and 21 for approximate storage times.

# Care and Cleaning

## Replacing Light Bulbs

### WARNING

To avoid electrical shock which can cause severe personal injury or death, disconnect power to refrigerator before replacing light bulb. After replacing light bulb, reconnect power.

### CAUTION

To avoid personal injury or property damage, observe the following:

- Allow light bulb to cool.
- Wear gloves when replacing light bulb.

## Fresh Food Section (style of light shield varies)

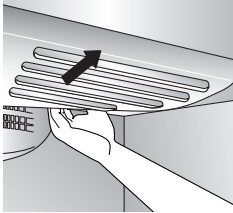
1. Slide clear light shield toward back of compartment to release from light assembly. 
2. Remove light bulbs.
3. Replace with appliance bulbs **no greater than 40 watts.**
4. Replace light bulb cover by inserting tabs on light shield into liner holes on each side of light assembly. Slide shield toward front of refrigerator until it locks into place. Do not force shield beyond locking point. Doing so may damage light shield.

## Freezer (style of light shield varies)

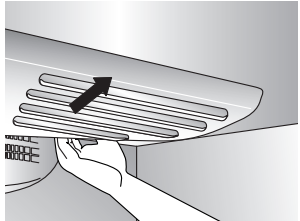
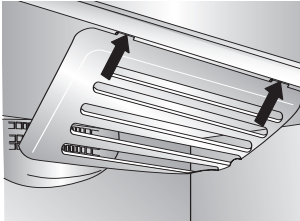
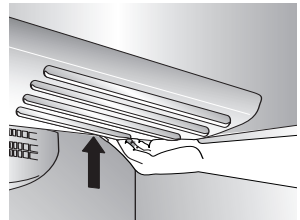
1. Reach behind the light cover. 
2. With firm pressure, press forward on the notches at the back of the cover and pull down. The cover will open from the back. 
3. Remove the cover.
4. Remove light bulb.
5. Replace bulb with appliance bulb **no greater than 40 watts.**
6. Insert front tabs of light cover into slots in freezer liner and snap rear portion over light assembly until rear tab engages. 



# Care and Cleaning

## Preparing for Vacation

### ⚠ CAUTION

If your refrigerator has a dispenser and if there is any possibility that the temperature can drop below freezing where the refrigerator is located, the water supply system (including the water tank and the water valve) must be drained by a qualified servicer.

#### For short vacations or absences (three months or less):

1. Remove all perishables.
2. If no one will be checking in on the refrigerator during your absence, remove all frozen items also.
3. If your refrigerator has an automatic ice maker:
  - Shut off the water supply to the ice maker at least one day ahead of time.
  - After the last load of ice drops, raise the wire shut off arm to the OFF position.
  - Empty the ice bin.
4. If the room temperature will drop below 55° F (13° C), follow the instructions for longer absences.

#### For long vacations, absences (more than three months) OR if the room temperature will drop below 55° F (13° C):

1. Remove food.
2. If your refrigerator has an automatic ice maker:
  - Shut off the water supply to the ice maker at least one day ahead of time.
  - After the last load of ice drops, raise the wire shut off arm to the OFF position.
  - Empty the ice bin.
3. If your refrigerator has a dispenser system with water filter, remove the water filter cartridge and install the filter bypass. Dispose of the used cartridge.
4. Turn the freezer control to OFF.
5. Unplug the refrigerator.
6. Thoroughly clean the interior of both compartments with a baking soda solution and a clean soft cloth (four tablespoons of baking soda in one quart of warm water).
7. Dry thoroughly.
8. Leave the doors open to prevent the formation of mold and mildew.

## Upon your return

#### After a short vacation or absence:

For models with automatic ice makers or dispensers:

- Reconnect the water supply and turn on supply valve (see pages 8-9).
- Monitor water connection for 24 hours and correct leaks if necessary.
- Run 10-15 glasses of water from the dispenser to flush out the system.
- Restart the ice maker by lowering the ice maker arm.
- Discard at least the first three ice harvests.

#### After a long vacation or absence:

- Reconnect the water supply and turn on supply valve (see pages 8-9).
- Plug the refrigerator back in and reset controls (see pages 10-12).
- Monitor water connection for 24 hours and correct leaks, if necessary.

For dispenser models, run water through the dispenser for at least three minutes with the filter bypass in place, then install water filter (see page 17).

- After installing the water filter, run water through the dispenser continuously for at least two minutes, or until water runs steady. Initially you may notice a one to two minute delay in water dispersal as the internal tanks fills.
- Restart the ice maker by lowering the ice maker arm.
- Discard ice produced within the first 12 hours (at least the first three harvests).

## Preparing to move

- Follow the above instructions for long vacations/absences, through step 7.
- Secure all loose items such as shelves and drawers by taping them securely in place to prevent damage.
- Tape the doors shut.
- Use an appliance dolly when moving the refrigerator. Always truck the refrigerator from its side or back - never from its front.
- Be sure the refrigerator stays in an upright position during moving.

# Operating Sounds

Improvements in refrigeration design may produce sounds in your new refrigerator that are different or were not present in an older model. These improvements were made to create a refrigerator that is better at preserving food, is more energy efficient, and is quieter overall. Because new refrigerators run quieter, sounds may be detected that were present in older refrigerators, but were masked by higher sound levels. Many of these sounds are normal. Please note that the surfaces adjacent to a refrigerator, such as hard walls, floors and cabinetry may make these sounds seem even louder. The following are some of the normal sounds that may be noticed in a new refrigerator.

SOUND	POSSIBLE CAUSE	SOLUTION
<b>Clicking</b>	• Freezer control <b>(A)</b> clicks when starting or stopping compressor.	• Normal operation
	• Motorized device <b>(B)</b> sounds like an electric clock and snaps in and out.	• Normal operation
<b>Air rushing or whirring</b>	• Freezer fan <b>(C)</b> and condenser fan <b>(D)</b> make this noise while operating.	• Normal operation
<b>Gurgling or boiling sound</b>	• Evaporator <b>(E)</b> and heat exchanger <b>(F)</b> refrigerant makes this noise when flowing.	• Normal operation
<b>Thumping</b>	• Ice cubes from ice maker (select models) drop into ice bucket <b>(G)</b> .	• Normal operation
<b>Vibrating noise</b>	• Compressor <b>(H)</b> makes a pulsating sound while running.	• Normal operation
	• Refrigerator is not level.	• See page 3 for details on how to level your refrigerator.
<b>Buzzing</b>	• Ice maker water valve <b>(I)</b> hookup (select models) buzzes when ice maker fills with water.	• Normal operation
<b>Humming</b>	• Ice maker <b>(J)</b> is in the 'on' position without water connection.	• Stop sound by raising ice maker arm to OFF position (see page 16).
	• Compressor <b>(H)</b> can make a high-pitched hum while operating.	• Normal operation
<b>Hissing or popping</b>	• Defrost heater <b>(K)</b> hisses, sizzles or pops when operational.	• Normal operation

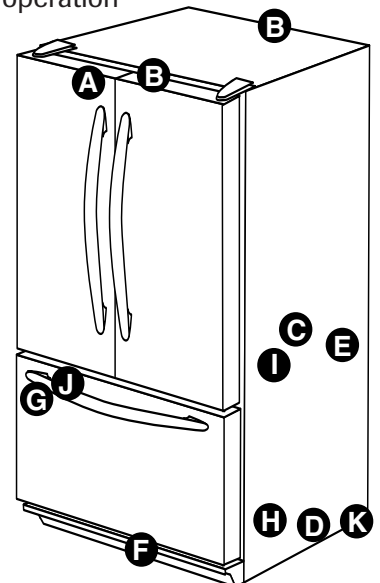



# Troubleshooting

PROBLEM	POSSIBLE CAUSES	WHAT TO DO	
<b>Freezer control and lights are on, but compressor is not operating</b>	Refrigerator is in defrost mode.	Normal operation. Wait 40 minutes to see if refrigerator restarts.	
<b>Crisper drawer temperature is too warm</b>	Control settings are too low.	See pages 10-12 to adjust controls.	
<b>Refrigerator does not operate</b>	Refrigerator is not plugged in.	Plug in refrigerator.	
	Control is not on.	See pages 10-12 to adjust your controls.	
	Fuse is blown, or circuit breaker needs to be reset.	Replace any blown fuses. Check circuit breaker and reset, if necessary.	
	Power outage has occurred.	Call local power company listing to report outage.	
<b>Refrigerator still won't operate</b>	Refrigerator is malfunctioning.	Unplug refrigerator and transfer food to another refrigerator. If another refrigerator is not available, place dry ice in freezer section to preserve food. Warranty does not cover food loss. Contact service for assistance.	
<b>Food temperature is too cold</b>	Condenser coils are dirty.	Clean according to the chart on page 22.	
	Refrigerator or freezer controls are set too high.	See pages 10-12 to adjust your controls.	
<b>Food temperature is too warm</b>	Door is not closing properly.	Refrigerator is not level. See page 3 for details on how to level your refrigerator. Check gaskets for proper seal. Clean, if necessary, according to the chart on page 22. Check for internal obstructions that are keeping door from closing properly (i.e. improperly closed drawers, ice buckets, oversized or improperly stored containers, etc.)	
	Controls need to be adjusted.	See pages 10-12 to adjust your controls.	
	Condenser coils are dirty.	Clean according to the chart on page 22.	
	Rear air grille is blocked.	Check the positioning of food items in refrigerator to make sure grille is not blocked. Rear air grilles are located under crisper drawers.	
	Door has been opened frequently, or has been opened for long periods of time.	Reduce time door is open. Organize food items efficiently to assure door is open for as short a time as possible.	
	Food has recently been added.	Allow time for recently added food to reach refrigerator or freezer temperature.	
	<b>Refrigerator has an odor</b>	Compartment is dirty or has odor-causing food.	Clean according to instructions on page 22.
	<b>Water droplets form on outside of refrigerator</b>	Check gaskets for proper seal.	Clean according to the chart on page 22.
Humidity levels are high.		Normal during times of high humidity.	
Controls require adjustment.		See pages 10-12 to adjust your controls.	

# Troubleshooting

PROBLEM	POSSIBLE CAUSES	WHAT TO DO
<b>Water droplets form on inside of refrigerator</b>	<ul style="list-style-type: none"> <li>Humidity levels are high or door has been opened frequently.</li> </ul>	<ul style="list-style-type: none"> <li>See pages 10-12 to adjust your controls.</li> <li>Reduce time door is open. Organize food items efficiently to assure door is open for as short a time as possible.</li> </ul>
	<ul style="list-style-type: none"> <li>Check gaskets for proper seal.</li> </ul>	<ul style="list-style-type: none"> <li>Clean, if necessary, according to the chart on page 22.</li> </ul>
<b>Refrigerator or ice maker makes unfamiliar sounds or seems too loud</b>	<ul style="list-style-type: none"> <li>Normal operation.</li> </ul>	<ul style="list-style-type: none"> <li>See page 16.</li> </ul>
<b>Crisper drawers do not close freely</b>	<ul style="list-style-type: none"> <li>Contents of drawer, or positioning of items in the surrounding compartment could be obstructing drawer.</li> </ul>	<ul style="list-style-type: none"> <li>Reposition food items and containers to avoid interference with the drawers.</li> </ul>
	<ul style="list-style-type: none"> <li>Drawer is not in proper position.</li> </ul>	
	<ul style="list-style-type: none"> <li>Refrigerator is not level.</li> </ul>	<ul style="list-style-type: none"> <li>See page 3 for details on how to level your refrigerator.</li> </ul>
	<ul style="list-style-type: none"> <li>Drawer channels are dirty or need treatment.</li> </ul>	<ul style="list-style-type: none"> <li>Clean drawer channels with warm, soapy water.</li> <li>Rinse and dry thoroughly.</li> <li>Apply a thin layer of petroleum jelly to drawer channels.</li> </ul>
<b>Refrigerator runs too frequently</b>	<ul style="list-style-type: none"> <li>Doors have been opened frequently or for long periods of time.</li> </ul>	<ul style="list-style-type: none"> <li>Reduce time door is open.</li> <li>Organize food items efficiently to assure door is open for as short a time as possible.</li> <li>Allow interior environment to adjust for period the door has been opened.</li> </ul>
	<ul style="list-style-type: none"> <li>Humidity or heat in surrounding area is high.</li> </ul>	<ul style="list-style-type: none"> <li>Normal operation.</li> </ul>
	<ul style="list-style-type: none"> <li>Food has recently been added.</li> </ul>	<ul style="list-style-type: none"> <li>Allow time for recently added food to reach refrigerator or freezer temperature.</li> </ul>
	<ul style="list-style-type: none"> <li>Refrigerator is exposed to heat by environment or by appliances nearby.</li> </ul>	<ul style="list-style-type: none"> <li>Evaluate your refrigerator's environment. Refrigerator may need to be moved to run more efficiently.</li> </ul>
	<ul style="list-style-type: none"> <li>Condenser coils are dirty.</li> </ul>	<ul style="list-style-type: none"> <li>Clean, if necessary, according to the chart on page 22.</li> </ul>
	<ul style="list-style-type: none"> <li>Controls need to be adjusted.</li> </ul>	<ul style="list-style-type: none"> <li>See pages 10-12 to adjust your controls.</li> </ul>
	<ul style="list-style-type: none"> <li>Door is not closing properly.</li> </ul>	<ul style="list-style-type: none"> <li>Refrigerator is not level. See page 3 for details on how to level your refrigerator.</li> </ul>
		<ul style="list-style-type: none"> <li>Check gaskets for proper seal.</li> </ul>
		<ul style="list-style-type: none"> <li>Clean, if necessary, according to the chart on page 22.</li> <li>Check for internal obstructions that are keeping door from closing properly (i.e. improperly closed drawers, ice buckets, oversized or improperly stored containers, etc.)</li> </ul>
	<ul style="list-style-type: none"> <li>Normal Operation</li> </ul>	<ul style="list-style-type: none"> <li>See <i>Operating Sounds</i> on page 26.</li> </ul>

# Troubleshooting

## Ice and Water

PROBLEM	POSSIBLE CAUSES	WHAT TO DO
<b>Refrigerator is leaking water</b>	<ul style="list-style-type: none"> <li>Plastic tubing was used to complete water connection.</li> </ul>	<ul style="list-style-type: none"> <li>The manufacturer recommends using copper tubing for installation. Plastic is less durable and can cause leakage. <b>The manufacturer is not responsible for property damage due to improper installation or water connection.</b></li> </ul>
	<ul style="list-style-type: none"> <li>Improper water valve was installed.</li> </ul>	<ul style="list-style-type: none"> <li>Check water connection procedure (see pages 8-9). Self-piercing and <math>\frac{3}{16}</math>" saddle valves cause low water pressure and may clog the line over time. <b>The manufacturer is not responsible for property damage due to improper installation or water connection.</b></li> </ul>
<b>Ice forms in inlet tube to ice maker</b>	<ul style="list-style-type: none"> <li>Water pressure is low.</li> </ul>	<ul style="list-style-type: none"> <li>Water pressure must be between 35 to 100 pounds per square inch to function properly. A minimum pressure of 35 pounds per square inch is recommended for refrigerators with water filters.</li> </ul>
	<ul style="list-style-type: none"> <li>Freezer temperature is too high.</li> </ul>	<ul style="list-style-type: none"> <li>Adjust freezer control (see page 10). Freezer is recommended to be approximately 0° F (-18° C).</li> </ul>
<b>Water flow is slower than normal</b>	<ul style="list-style-type: none"> <li>Water pressure is low.</li> </ul>	<ul style="list-style-type: none"> <li>Water pressure must be between 35 to 100 pounds per square inch to function properly. A minimum pressure of 35 pounds per square inch is recommended for refrigerators with water filters.</li> </ul>
	<ul style="list-style-type: none"> <li>Improper water valve was installed.</li> </ul>	<ul style="list-style-type: none"> <li>Check water connection procedure in your Installation Instructions. Self-piercing and <math>\frac{3}{16}</math>" saddle valves cause low water pressure and may clog the line over time. <b>The manufacturer is not responsible for property damage due to improper installation or water connection.</b> Open water valve completely and check for leaks.</li> </ul>
	<ul style="list-style-type: none"> <li>Copper tubing has kinks.</li> </ul>	<ul style="list-style-type: none"> <li>Turn off water supply and remove kinks. If kinks cannot be removed, replace tubing.</li> </ul>
	<ul style="list-style-type: none"> <li>Water filter is clogged or needs to be changed.</li> </ul>	<ul style="list-style-type: none"> <li>Change water filter (see page 17).</li> </ul>

Brand: **Maytag, Amana, Jenn-Air**

Date: February 25, 2005

Product Type: **Refrigeration**

Product Sub-System: **System Operation**

Models Affected: **New 2005 Electronic Refrigerators**

Maytag is introducing a new electronic control for refrigeration products.

This control will be used in the more advanced models of refrigerators including the Wide by Side and the French Door refrigerators. The current Mid-Level control that was introduced in the last half of 2004 will still be an option for temperature control in similar models.

This solid-state module provides compressor, damper, defrost and temperature control. There are three thermistors used for temperature management. One thermistor is in each compartment plus one thermistor found in the machine compartment.

A major departure from past controls, this controller is programmed with the information it needs to operate any of the compatible variety of refrigerators. When installed, the controller needs to be activated by entering a code that matches the refrigerator it is going to operate. This code will be located on the serial number tag. The word code will be printed, followed by the proper code for that refrigerator. This code is also referred to as the personality for the control.

The controller will also allow individual components to be powered during diagnosis.

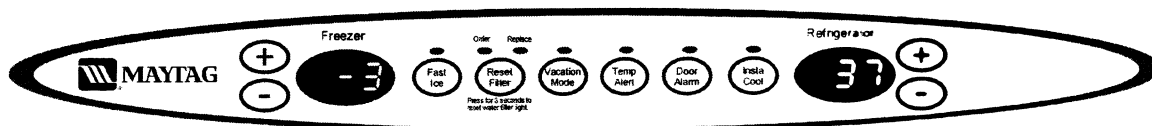

One of the most noticeable changes with the new control is the use of temperature displays for the set point. Several user options are also included on the control. Built into the control is an exhaustive service and diagnostic program.

The defrost system is both adaptive and preemptive. The compressor run time between defrosts will adjust based on the time between the start of a defrost cycle and when the defrost terminator opens. This will decrease the run time between defrosts when frost is heavier and extend the run time when frost loads are light. The preemptive feature monitors the frequency of door openings and adjusts defrost timing to avoid high usage periods. Prior to each defrost cycle, the freezer temperature is intentionally decreased to help prevent freezer burn.

Some side by side products add a stirrer fan in the fresh food compartment. This additional fan will help to prevent stratification throughout the compartment. The stirrer fan will operate any time the fresh food door is opened as well as whenever the evaporator fan is not running and the door is closed.



**Customer Options**

The following features are discussed in the owner's manual and are customer options

**Fast Ice**

The *Fast Ice* function will lower the freezer temperature to minimum and allow for more frequent ice harvests. The freezer evaporator fan will run for two hours after each ice fill. The freezer temperature display will indicate the actual freezer temperature and the freezer temperature adjustment buttons will not change the set temperature. This function will cancel after 48 hours.

**Reset Filter**

The yellow indicator will light when the filter has reached 90% of the rated capacity. A red indicator will light when the filter has reached 100% of capacity. When installing a new filter, press and hold the *Reset Filter* pad for three seconds.

**Vacation Mode**

The *Vacation Mode* extends the compressor run time between defrosts to the maximum duration. This run time is used after the next scheduled defrost cycle has completed. The vacation mode will cancel when the door is opened. The control will ignore door openings for the first hour after the mode is initiated to allow for last minute door openings before heading off on vacation.

**Temp Alert**

The *Temp Alert* will provide two types of temperature warnings. To turn this feature off, the button must be pressed for three seconds.

If the freezer temperature rises above +15°F for 1½ hour or the fresh food section gets warmer than 50°F for one hour the *Temp Alert* will activate. The temperature displays will alternate between the current temperatures and the warmest temperatures reached. If the display is alternating 55 and 37 this indicates that the cavity is currently 37 degrees but did reach 55 degrees.

If after a loss of power, if the freezer is above 15°F or the fresh food section is above 50°F, the temperature alarm will activate and indicate the highest temperature measured alternating with the current temperature. This feature is ignored for the first six hours of operation after installation.

**Door Alarm**

The *Door Alarm* will sound if either door remains open for more than five minutes.

**Insta Cool**

The *Insta Cool* feature overrides any set temperatures for twelve hours. The target temperature will be the minimum control temperature. The display will indicate the current temperature but the temperature adjustment buttons will not function.

**Hidden Options**

There are four hidden customer options. These are accessed through a menu system.

The additional options are accessed by pressing the *Door Alarm* button for three seconds. The freezer temperature display will indicate the option that is currently

available for setting. To scroll through the different options, use the freezer temperature adjustment buttons.

The refrigerator temperature display will indicate whether the function is ON or OFF or, in the case of the temperature mode, Fahrenheit or Celsius. The temperature adjustment buttons will change the setting.

To exit the user options and save the changes to these settings, press the door alarm button for three seconds.

The extended options are summarized by the following table:

Feature	Freezer Display	Settings (Refrigerator Display)	Notes
Sabbath Mode	SAB	ON or OFF	Displays and indicators will not light.
°F or °C Display Selection	F_C	F or C	Changes temperature scale.
Audible Alarms	AL	ON or OFF	Turns off audible alarms but not the alarm features.
Fresh Food Fan (Optional)	CC	ON or OFF	Turns fresh food stirrer fan on or off.
Light Level	LL	ON or OFF	Changes auto light level setting.

This list of features could increase or decrease with future revisions to the control.

The complete control system will be made up of two or three circuit boards. In refrigerators without dispensers there will only be two boards. In machines with dispensers there will be three boards.

The main control board is located in the machine compartment. All control operated components are switched from this board. The user interface and the dispenser boards are user input boards only. The main circuit board provides the interface boards with twelve volts DC. Communication between the boards is through a two wire data system.

**Thermistors**

All the thermistors in the system have a negative temperature coefficient. As the temperature increases, the resistance decreases. If the temperature decreases, the resistance increases.

If a thermistor were to open or short the control will react as though the thermistor was sending a reading back that indicated an extreme condition.

If the Fresh Food or Freezer thermistor were to short, the system would assume the temperature was high and compressor runtimes would be excessive with very low compartment temperatures because of the long run time.

If the thermistor was open, the system would assume the compartment was sufficiently cool and no additional cooling would be called for. In the case of an open freezer compartment thermistor, the compressor would not turn on properly. In the case of an open Fresh Food thermistor, the damper would not open to allow cool air from the freezer compartment to cool the fresh food compartment.

The machine compartment thermistor is used to adjust the total temperature management system for highest efficiency while maintaining desired compartment temperatures. Since the compartment temperature is not exactly the same as the thermistor temperature, a program is used to provide an approximate temperature that will in most cases result in a slightly cooler thermistor temperature than the compartment air temperature. At high ambient temperatures the program is adjusted to provide the customer with the target temperature they desire.

**Service Modes**

At this time there are four modes available to the technician that will assist in troubleshooting and repair. These modes are: Programming Mode, Showroom Mode, Forced Defrost Mode and Service Test Mode.

Entering any of the modes is a two-step process. First the mode must be requested by pressing the door alarm keypad followed by the correct freezer or refrigerator up or down keypad. These modes will exit by closing the refrigerator door or after four minutes of inactivity

Mode	Activation Button	Freezer Display	Ref Display
Programming	Door Alarm/Freezer Temp Down	PE	
Showroom	Door Alarm Freezer Temp Up	SH	On/Off
Forced Defrost	Door Alarm Refrigerator Temp Down	Fd	SH
Service Test	Door Alarm Refrigerator Temp Up	SE/001	---

## Programming Mode

The replacement control board is shipped with no active code entered into the board. The display will indicate a code of 0000. Without a code entered into the control board the refrigerator will not run. Also it is important that the correct code be entered into the control board, or the refrigerator will not operate properly.

To enter the programming mode so the correct code may be set, open the refrigerator door and hold the door alarm keypad. While holding the door alarm keypad press and hold the freezer temperature down keypad. Release the door alarm keypad while holding the freezer temperature down keypad for three seconds.

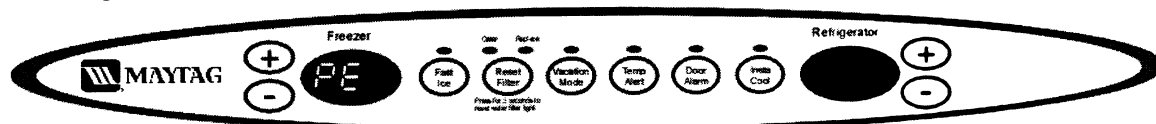

After three seconds the control will display PE in the freezer display. When PE is displayed release the freezer temperature down keypad. Entry is confirmed into the programming mode by pressing the freezer temperature down keypad once more.

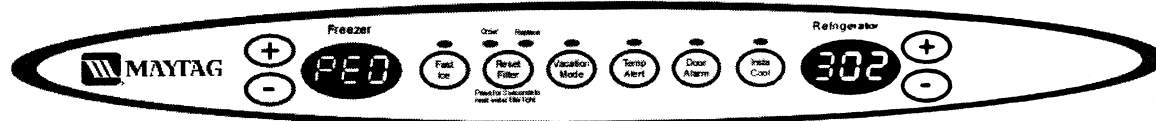

The control will display the current program code. If the program code is correct, the programming mode is exited by closing the refrigerator door. This value should be validated with the program code printed on the serial tag, located in the refrigerator section. Pressing the refrigerator temperature up or down refrigerator keypad will change the digit value and pressing the freezer temperature up keypad will select the next digit. The currently selected digit is indicated with the placement of a decimal point at the lower right of the digit.

Once the desired program code is entered, press and hold the freezer temperature down keypad until the display begins flashing indicating it has been saved. If an invalid program code is entered the control will not save it, but will beep and the refrigerator will not run with a program code of 0000. After the program code flashes the mode is exited by closing the refrigerator door. If an invalid code is entered this process should be repeated after closing the refrigerator door. Also closing the refrigerator door at any time during this mode will cancel the programming mode. The control will also exit the programming mode if there is no activity for four minutes

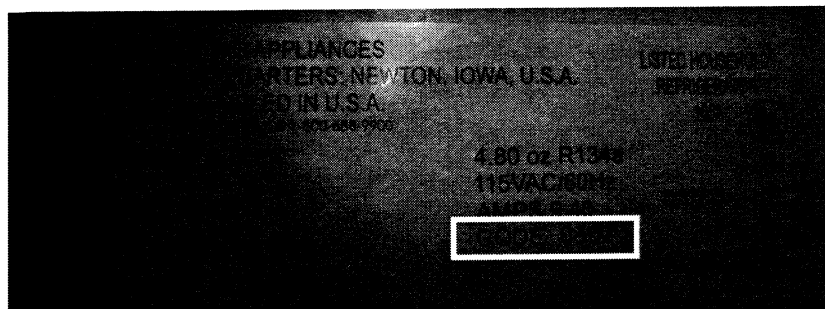

## Showroom Mode

The showroom mode will allow for demonstration of the electronic control without the cooling system being energized. This is for display purposes only. To enter the showroom mode, open the refrigerator door press and hold the door alarm keypad. While holding the door alarm keypad press and hold the freezer up keypad. Release the door alarm keypad and continue to hold the freezer up keypad for three seconds, SH will appear in the freezer display. When SH appears in the freezer display release the freezer up keypad.

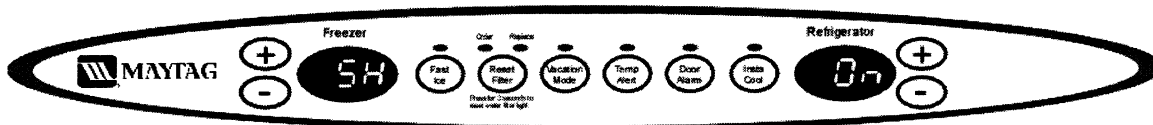

Press the freezer up keypad again will confirm entry into the showroom mode and either On or OFF will be displayed in the refrigerator display. Pressing the up refrigerator keypad will toggle the showroom mode on and off. After the on or off mode is selected confirm entry by pressing the freezer up keypad. Removing power will cancel the showroom mode

## Forced Defrost Mode

The forced defrost function is performed using the freezer display and the refrigerator keypad. Enter the forced defrost mode by performing the following sequence of events. Open the refrigerator door press the door alarm keypad. While holding the door alarm keypad press and hold the refrigerator temperature down keypad release the door alarm keypad and hold the refrigerator temperature down keypad for three seconds.

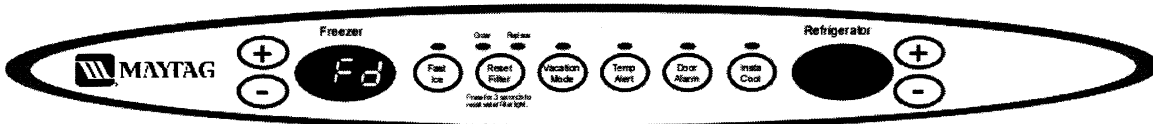

After three seconds Fd will appear in the freezer display. When Fd appears in the freezer display release the refrigerator down keypad.

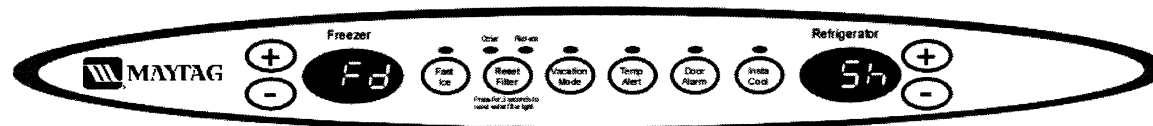

Press the refrigerator down keypad again and SH will appear in the refrigerator display. Pressing the refrigerator temperature down keypad again will force a defrost Fd and SH will flash in the display indicating the refrigerator is in a forced defrost.

## Service Test Mode

The service test functions are performed using both the refrigerator and freezer display and keypad. Enter the service test mode by performing the following sequence of events. Open the refrigerator door, press and hold the door alarm keypad. While holding the door alarm keypad press and hold the refrigerator temperature up keypad. Release the door alarm keypad and continue to hold the refrigerator temperature up keypad for three seconds.

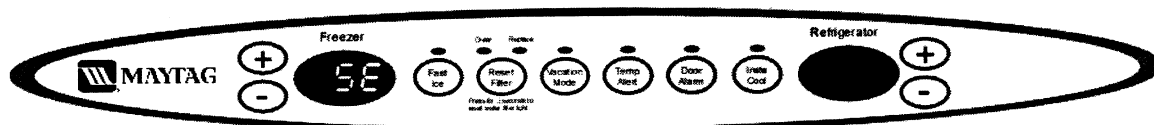

When SE appears in the freezer window release the refrigerator temperature up keypad.

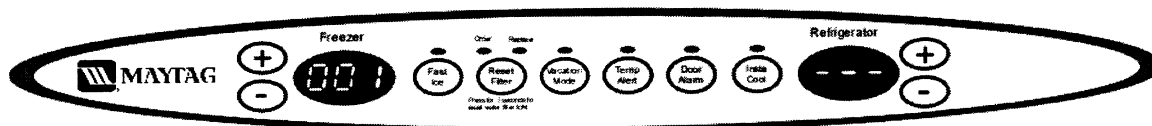

Press the refrigerator temperature up keypad again to confirm entry into the service mode the freezer will display 001 and the refrigerator will display dashes. Pressing the freezer up and down keypad will toggle through the service tests. The refrigerator temperature up and down keypads will activate the test.

## Service Test Mode

There are several service test modes available to the technician. These modes can be used to operate various components in the refrigerator as well as test some of the components. The different service test modes are summarized in the following table.

Service Test	Service Test Name	Indications
101	Defrost Heater & Defrost Circuit	<p>This test will either energize or de-energize the defrost circuit. The refrigerator display will show:</p> <p>OFF when de-energized</p> <p>OP when energized with an open defrost thermostat</p> <p>CL when energized with a closed defrost thermostat</p>
102	Condenser Fan	<p>Energizes the Condenser Fan on and off. The refrigerator display will Show the state either On or OFF.</p>

111	Fresh Food Fan	Energizes the Fresh Food Fan on or off. The refrigerator display will Show the state either OFF or DC voltage.
112	Freezer Fan	Energizes the freezer Fan on or off. The refrigerator display will Show the state either OFF or DC voltage.
121	Damper Operation	Cycles the electronic damper open and closed (OP) for open and (CL) for closed. Requires one minute between changes in state.
141	Fresh Food Thermistor Test	Tests the fresh food compartment thermistor circuit and displays condition in the fresh food temperature selection display. The display will either show: Fresh Food Temperature: OP indicates an Open thermistor SH indicates a Shorted thermistor



142	Freezer Thermistor Test	<p>Tests the freezer compartment thermistor circuit and displays condition in the fresh food temperature selection display. The display will either show:                      Freezer Temperature:                      OP indicates an Open thermistor                      SH indicates a Shorted thermistor</p>
143	Machine Compartment Thermistor	<p>Tests the Machine compartment thermistor circuit and displays condition in the fresh food temperature selection display. The display will either show:                      Machine Compartment Temperature                      OP indicates an Open thermistor                      SH indicates a Shorted thermistor</p>
151	Fresh Food Door State	<p>Will show the state of the fresh food door:                      OP indicates open                      CL indicates closed</p>

152	Freezer Door State	<p>Will show the state of the freezer door:                      OP indicates open                      CL indicates closed</p>
161	Cube Dispenser	<p>Shows the state of the cube dispenser:                      ON                      OFF</p>
162	Crusher Dispenser	<p>Shows the state of the crusher dispenser:                      ON                      OFF</p>
163	Water Dispenser	<p>Shows the state of the water dispenser:                      ON                      OFF</p>

164	Ice Chute Dispenser	Shows the state of the ice chute dispenser: ON OFF
165	Dispenser Lamp	Shows the state of the dispenser lamp: ON OFF
171	Actuator Pad	Shows the state of the Actuator pad: ON OFF
172	Sports Fill	Shows the state of the sports fill: ON OFF

173	Ambient Light	Refrigerator display will show the light sensor measurement either Hi or Lo.
175	Dispenser Line	Refrigerator will show the state of the dispenser line On or OFF.
181	Keypad Operation	Display shows a numeric or letter display indicating the last key pressed.
182	LED Indicator Operation	Shows operation of LED indicators. All LED's will flash.
191	Ice Maker Water Valve	Display shows the state of the ice maker water valve.

202	Default Defrost Operation	Change defrost operation from normal adaptive defrost in the OFF position to minimum time defrost in the On position.
203	Show Temperature Set Point	This test will allow for either showing actual temperature in the OFF position or show temperature set point only in the On position.
211	Fresh Food Temperature Adjustment	Adjusts Fresh Food Thermistor offset. Increasing the value will decrease the temperature in the Fresh Food compartment.
212	Freezer Temperature Adjustment	Adjusts Freezer Thermistor offset. Increasing the value will decrease the temperature in the Freezer compartment.
221	Reset Default Settings	This test will reset all factory settings DEF will be in the refrigerator display.

