

Service

Commercial Microwave Oven

This manual replaces RS2220001 Rev. 2.

Service Manual for
Amana®

Models and manufacturing numbers in this manual

DQ22HS	P1198607M
DQ22HS	P1107908M
DQ22HS	P1198617M
KFC1	P1198622M
MC22MP	P1198701M
MC22MP	P1107904M
MC22MP	P1198703M
MC22MP	P1198706M
MC22MPT	P1198702M
MC22MPT	P1198704M
MC22MPT	P1198707M
MC22MPT2	P1198705M
MC22MPT2	P1198708M
RC16MP	P1191101M
RC17	P1191104M
RC17	P1198601M
RC17	P1198612M
RC17SD	P1198623M
RC20A	P1198603M
RC20A	P1191103M
RC22	P1107909M
RC22	P1198604M
RC22	P1198614M
RC22LW	P1198610M
RC22LW	P1198611M
RC22MP	P1107902M
RC22MPS	P1107906M
RC22S	P1198605M
RC27	P1198608M
RC27	P1198618M
WDYRC	P1198621M

This manual is to be used by qualified appliance technicians only. Amana does not assume any responsibility for property damage or personal injury for improper service procedures done by an unqualified person.

The Amana logo is written in a bold, italicized, sans-serif font.

RS2220001
Revision 3
November 2000

IMPORTANT PRODUCT INFORMATION



WARNING

Precautions to be observed before and during servicing to avoid possible exposure to excessive microwave energy, or electrical shock disconnect power to oven.

- (A) Do not operate or allow oven to be operated with door open.
- (B) Make the following safety checks on all ovens to be serviced before activating the magnetron or other microwave source, and make repairs as necessary:
 - Interlock operation
 - Proper door closing
 - Seal and sealing surfaces (arcing, wear, and other damage)
 - Damage to or loosening of hinges and latches
 - Evidence of dropping or abuse
- (C) Before turning on microwave power for any service test or inspection within the microwave generating compartments, check the magnetron, waveguide or transmission line, and cavity for proper alignment, integrity, and connections.
- (D) Any defective or misadjusted components in the interlock, monitor, door seal, and microwave generation and transmission systems shall be repaired, replaced or adjusted by procedures described in this manual before oven is released to the consumer.
- (E) Check microwave leakage to verify compliance with the federal performance standard should be performed on each oven prior to release to the consumer.



WARNING

To avoid risk of electrical shock, injury, or death, make sure these grounding instructions are followed.

Grounding Instructions



WARNING

Do not remove grounding prong when installing grounded appliance in a home or business that does not have three wire grounding receptacle, under no condition is grounding prong to be cut off or removed. It is the personal responsibility of the consumer to contact a qualified electrician and have properly grounded three prong wall receptacle installed in accordance with appropriate electrical codes

Servicing of Grounded Products

The standard accepted color coding for grounding wires is GREEN or GREEN WITH YELLOW STRIPE. These ground leads are NOT to be used as current carrying conductors. It is extremely important that the technician replace any and all grounds prior to completion of the service call. Under no condition should ground wire be left off causing a potential hazard to technicians and consumer.

WIRING

Good service practice is to never route wiring over terminals and/or sharp edges. This applies to any wiring without regard to the circuit voltage. Wire insulation material and thickness is designed and regulated for electrical spacing purpose only, but cannot always be relied upon because of possible cuts and/or abrasions, which can occur during servicing.

Table of Contents

Important Product Information	2	Component Testing Procedures	17
Important Information	4	Display Diagnostics	
Important Safety Information	5	Service Codes	21
Microwave Leakage Testing	6	S1 Watchdog - Membrane Touch Panel	22
Equipment	6	HOT Magnetron Overheating	22
Procedure For Measuring Radiation Leakage	6	CS Current Sense	22
Measurement With the Outer Panel Removed	6	PCE1 Checksum	23
Measurement With a Fully Assembled Oven	6	PCE5 Communication Failure	23
Record Keeping and Notification After Measurement	6	PCE6 Communication Failure	23
Specifications	7	HI High Line Voltage	23
Installation		LO Low Line Voltage	23
Installation	8	Service Test – All Models Except WDYRC	
Care and Cleaning	8	Accessing Service Test Mode	24
Replacing Oven Light Bulb	8	H.V. System Test	24
Product Information		Diagnosing Individual H.V. System Components	24
Antennas, Antenna Gears, Antenna Motors	9	Door Cycles and Magnetron Hours	25
Autotransformer	9	Power Test (Traditional 1 Liter Test)	26
Blower/Fan Assembly	9	Troubleshooting	
Power Relay	9	Initial Power Up	27
Door Interlock and Monitoring Switch	9	Stand By Condition	28
Grease Shield	9	Cook Condition	29
Transformers	9	Disassembly	
High Voltage Capacitor	9	Latch Handle	30
High Voltage Diode (Rectifier)	9	Door	30
Magnetron	9	Outer Case	30
Thermal Protectors	9	Inner Door Ring Assembly	30
Keypads	9	Hinge	30
Triac	9	Bottom Shelf	31
Operating Instructions		Grease Shield	31
Control Panel	10	Outer Case	31
Pads	10	Top Keypad	31
Readout Display	10	Side Keypad	31
"RC" Operating Instructions		Low Voltage Circuit Board	31
Preprogrammed Pads	11	Top Antennas	32
Operating Preprogrammed Pads	11	Top Antenna Motor	32
Variable Time Entry	11	Antenna Matching	32
Summary of Programming Multiple Stages	11	Interlock Switch Module	33
Operating Notes	11	Top Rear Magnetron	33
"DQ & MC" Operating Instructions		Top Front Magnetron	33
Preprogrammed Menu Items	12	Bottom Magnetron	34
Operating Preprogrammed Menu Items	12	Magnetron and Control Thermal Protectors (TCO) ..	34
Variable Time Entry	12	Bottom Access Panel	34
Operating Notes	12	Bottom Stirrer Motor	34
Programming Menu Items	13	Bottom Antenna	35
Programming Multiple Stages	13	Back Panel	35
Specialized Programs		Blower Wheel and Motor	35
[QTY] Quantity (RC16, RC17, RC20, RC22, RC27)	14	Fan Blade	36
[LMT] Limit (All Models)	14	H.V. Board	36
Programming PAUS	15	Cavity Thermal Protector (TCO)	36
Using PAUS Function	15	Power Cord	36
Option Programs (All Models Except WDYRC)	15	Component Location	36
WDYRC Operating Instructions	16	Wiring Diagrams and Schematics	39–60

Important Information

Pride and workmanship go into every product to provide our customers with quality products. It is possible, however, that during its lifetime a product may require service. Products should be serviced only by a qualified service technician who is familiar with the safety procedures required in the repair and who is equipped with the proper tools, parts, testing instruments and the appropriate service manual. **REVIEW ALL SERVICE INFORMATION IN THE APPROPRIATE SERVICE MANUAL BEFORE BEGINNING REPAIRS.**

Important Notices for Consumers and Servicers

WARNING

To avoid risk of serious injury or death, repairs should not be attempted by an unauthorized personal, dangerous conditions (such as exposure to electrical shock) may result.

CAUTION

Amana will not be responsible for any injury or property damage from improper service procedures. If performing service on your own product, assume responsibility for any personal injury or property damage which may result.

To locate an authorized servicer, please consult your telephone book or the dealer from whom you purchased this product. For further assistance, please contact 1-800-628-5782 first, if no answer contact the following number.

CONSUMER AFFAIRS DEPT.
AMANA APPLIANCES, INC.
AMANA, IOWA 52204

**OR
CALL**

1-319-622-5511 or (1-800-843-0304)
and ask for
Consumer Affairs

If outside the United States contact:

AMANA
ATTN: CONSUMER AFFAIRS DEPT
AMANA, IOWA 52204, USA
Telephone: (319) 622-5511
Facsimile: (319) 622-2180
TELEX: 4330076 AMANA
CABLE: "AMANA", AMANA, IOWA, USA

Recognize Safety Symbols, Words, and Labels

DANGER

DANGER - Immediate hazards which **WILL** result in severe personal injury or death.

WARNING

WARNING - Hazards or unsafe practices which **COULD** result in severe personal injury or death.

CAUTION

CAUTION - Hazards or unsafe practices which **COULD** result in minor personal injury or product or property damage.

Important Safety Information



CAUTION

Read the following information to avoid possible exposure to microwave radiation.

The basic design of the Amana Microwave Oven makes it an inherently safe device to both use and service. However, there are some precautions which should be followed when servicing microwave oven to maintain this safety. These are as follows:

1. Always operate unit from an adequately grounded outlet. Do not operate on a two-wire extension cord.
2. Before servicing unit (if unit is operable) perform microwave leakage test.
3. The oven should never be operated if the door does not fit properly against the seal, hinges or hinge bearings are damaged or broken; the choke is damaged, (pieces missing, etc.); or any other visible damage can be noted. Check choke area to ensure that this area is clean and free of all foreign matter.
4. If the oven operates with door open and produces microwave energy, take the following steps:
 - A. Tell the user not to operate the oven.
 - B. Contact Amana Refrigeration, Inc. immediately.
5. Always have oven disconnected when the outer case is removed except when making "live" tests called for in the service manual. Do not reach into equipment area while unit is energized. Make all connections for the test and check them for tightness before plugging cord into outlet.
6. Always ground capacitors on magnetron filter box and H.V. capacitor with an insulated-handle screwdriver before working in high voltage area of equipment compartment. Some types of failures will leave a charge in these capacitors and the discharge could cause a reflex action which could make you injure yourself.
7. In the area of the transformer, capacitor, diode, and magnetron there is HIGH VOLTAGE. When the unit is operating - keep this area clean and free of anything which could possibly cause an arc or ground, etc.
8. Do not for any reason defeat interlock switches - there is no valid reason for this action at any time; nor will it be condoned by Amana.
9. IMPORTANT: Before returning a microwave to a customer, check for proper switch interlock action. The primary and secondary switches MUST open when the door handle is actuated. The monitor switch MUST close at 1/4 inches when the door is opened. (See Service Section for detailed instructions.
10. Before returning a microwave to a customer, verify the door spacing is reasonably uniform along the top, bottom, and sides, and that it measures 1/8-inch or less.
11. The Amana microwave oven should never be operated with:
 - Any components removed and/or bypassed.
 - Any of the safety interlocks are found to be defective.
 - Any of the seal surfaces are defective, missing, or damaged.
12. To ensure that the unit does not emit excessive microwave leakage and to meet Department of Health and Human Services guidelines check oven for microwave leakage using Narda Model 8100, 8200, Holaday HI1500, HI1501, or Simpson 380M leakage monitor as outlined in instructions on the following page. The maximum leakage level allowed is $4\text{mw}/\text{cm}^2$.
13. If servicer encounters an emission reading over $4\text{mw}/\text{cm}^2$ the servicer is to cease repair and contact Amana Service Department immediately for further direction. Amana Refrigeration, Inc. will contact the proper Government Agency upon verification of the test results.

Microwave Leakage Testing

WARNING

Check for radiation leakage after servicing. Should the leakage be more than $4\text{mW}/\text{cm}^2$ inform Amana Refrigeration, Inc. immediately. After repairing or replacing any radiation safety device, keep a written record for future reference, as required by D.H.H.S. and HEW regulations. This requirement must be strictly observed. In addition, the leakage reading must be recorded on the service repair ticket while in the customer's home.

Equipment

- Electromagnetic radiation monitor
- 600 cc glass beaker

Procedure For Measuring Radiation Leakage

Note before measuring -

- Do not exceed meter full scale deflection. Leak monitor should initially be set to the highest scale.
 - To prevent false readings the test probe should be held by the grip portion of the handle only.
 - The scan speed is equal to one inch per antenna revolution or one inch per second if antenna speed is unknown.
 - Areas to be checked are all door seal areas and any venting parts.
 - Leakage with the outer panel removed... $4\text{mW}/\text{cm}^2$ or less.
 - Leakage for fully assembled oven with door normally closed ... $4\text{mW}/\text{cm}^2$ or less.
 - Leakage for a fully assembly oven (before the latch switch (primary) is interrupted) while pulling the door ... $4\text{mW}/\text{cm}^2$ or less.
1. Pour 275 ± 15 cc (9 oz \pm 1/2 oz) of $20 \pm 5^\circ\text{C}$. ($68 \pm 9^\circ\text{F}$.) water in a beaker which is graduated to 600 cc and place the beaker in the center of oven.
 2. Set the radiation monitor to 2450 MHz and use it following the manufacturer's recommended test procedure to assure correct results.
 3. While measuring the leakage, always use the two inch (5 cm) spacer supplied with the probe.
 4. Press the START pad or turn on the timer and with the magnetron oscillating, measure the leakage by holding the probe perpendicular to the surface being measured.

Measurement With the Outer Panel Removed

DANGER

Avoid contacting any high voltage components.

Whenever you replace the magnetron, measure for radiation leakage before the outer panel is installed and after all necessary components are replaced or adjusted. Special care should be taken in measuring around the magnetron.

Measurement With a Fully Assembled Oven

After all components, including the outer panel are fully assembled, measure for radiation leakage around the door periphery, the door viewing window, the exhaust opening, and air inlet openings.

Record Keeping and Notification After Measurement

1. After any adjustment or repair to a microwave oven, a leakage reading must be taken. Record this leakage reading on the repair ticket even if it is zero.
2. A copy of the repair ticket and the microwave leakage reading should be kept by the repair facility.

Specifications

Models	RC16MP	RC17 RC17SD	RC20A	DQ22HS RC22 RC22LW RC22S RC22MP RC22MPS	MC22MP MC22MPT MC22MPT2	KFC1 RC27	WDYRC
Power Source							
Voltage AC	208/230	208/230	208/230	208/230	208/230	208/230	208/230
Amperage (single unit)	20	20	20	20	20	30	20
Frequency	60 Hz	60 Hz	60 Hz	60 Hz	60 Hz	60 Hz	60 Hz
Single Phase, 3 wire grounded	X	X	X	X	X	X	X
Receptacle	6-20R	6-20R	6-20R	6-20R	**	6-30R	6-20R
Plug	6-20P	6-20P	6-20P	6-20P	**	6-30P	6-20P
Power Output							
Nominal microwave energy (IEC705)	1600 watts	1700 watts	2000 watts	2200 watts	2050 watts	2700 watts	2000 watts
Operating Frequency	2450 MHz	2450 MHz	2450 MHz	2450 MHz	2450 MHz	2450 MHz	2450 MHz
Power Consumption							
Cook Conditions	3200 watts	3400 watts	4000 watts	4300 watts	3500 watts	4500 watts	3500 watts
Dimensions							
Cabinet							
Width	19 1/4"	19 1/4"	19 1/4"	19 1/4"	19 1/4"	19 1/4"	19 1/4"
Height	18"	18"	18"	18"	18"	18"	18"
Depth	24"	24"	24"	24"	24"	24"	24"
Oven Interior							
Width	13 3/16"	13 3/16"	13 3/16"	13 3/16"	13 3/16"	13 3/16"	13 3/16"
Height	8 3/4"	8 3/4"	8 3/4"	8 3/4"	8 3/4"	8 3/4"	8 3/4"
Depth	14 7/8"	14 7/8"	14 7/8"	14 7/8"	14 7/8"	14 7/8"	14 7/8"
Weight							
Crated	101 lbs.	101 lbs.	101 lbs.	114 lbs.	114 lbs.	114 lbs.	114 lbs.

- * Suffix designates different features in similar ovens.
- ** MC22MP uses 20A Hubbell 320P6WM2 plug.
- ** MC22MPT uses 20A Twist-Loc NEMA # L6-20P plug.
- ** MC22MPT2 uses 20A Hubbell HBL2321S plug.

Installation

Installation

Unpacking Oven

- Inspect microwave oven for damage such as dents in door or inside oven cavity.
- Report any dents or breakage to source of purchase immediately.

Oven Placement

- Do not install microwave oven next to or above source of heat, such as pizza oven or deep fat fryer. Excessive heat may cause oven to operate improperly and shorten life of electrical parts.
- Allow air flow around unit. Leave at least 1 1/2 inches between air discharge on back of oven and back wall. Restricted air flow may cause oven to operate improperly and shorten life of electrical parts.

Care and Cleaning

Interior, Exterior and Door

1. Wash surfaces with a soft, clean cloth and mild detergent diluted in warm water. Remove excess water from cloth before wiping oven. If desired, boil a cup of water in oven to loosen soil before cleaning.
2. Do not use cleaners containing ammonia.
3. Never pour water into oven bottom.
4. Do not use water pressure type cleaning systems.

Discharge Air Vents

There will be a slight buildup of cooking vapors along discharge louvers in back of oven on left side as viewed from the front. Clean air vent with damp cloth. Dry thoroughly.

Air Filter

Air filter is located under oven directly below door.

1. Remove air filter by turning thumb screws counterclockwise, located on outside edges of filter.
2. Wash filter with mild detergent diluted in warm water. Rinse and dry thoroughly.
3. Replace filter by reversing step 1.

Splatter Shield

Splatter shield keeps top of oven and antenna from getting dirty. Remove soil from shield with damp cloth.

NOTE: When removing and replacing splatter shield, be careful not to bend antenna.

1. Unplug oven before removing splatter shield to stop antenna from rotating.
2. Remove shield by placing thumbs in front of shield. Press firmly toward back and carefully lower front of shield away from antenna. Pull shield forward, out of back slots and out of oven.
3. Wash shield in hot, soapy water. Rinse and dry thoroughly.
4. Replace splatter shield by fitting tabs into slots at top of oven back. Lift and press front of shield until shield snaps into place.

Important

- Do not wash splatter shield in dishwasher.
- Do not use abrasive cleaners

Replacing Oven Light Bulb



WARNING

To avoid electrical shock which can cause severe personal injury or death, unplug power cord or open circuit breaker to oven before replacing light bulb. After replacing light bulb, restore power.

Tools Needed

- Protective gloves
- Phillips screwdriver
- 40-watt, 250-volt appliance bulb (available at Amana Authorized Service Centers - p/n A0282802)



CAUTION

To avoid personal injury or property damage, observe the following:

1. Allow light bulb to cool.
 2. Wear gloves when replacing light bulb.
1. Remove screw from access cover on top left wall of oven exterior. Remove access cover.
 2. Remove bulb.



To remove bulb, turn it in the direction shown.

3. Replace bulb.
4. Replace access cover and screw by reversing procedure in step 1.

Product Information

Antennas, Antenna Gears, Antenna Motors

Properly distributes microwave energy throughout the cavity.

Autotransformer

This transformer provides step-up voltage for the blower motor, antenna motors, and oven light.

Blower/Fan Assembly

Circulates cooling air throughout the machine compartment and cavity.

Power Relay

The power relay is actuated by the digital timer. The contacts on this relay complete one side of the power line to the high voltage power transformer.

Door Interlock and Monitoring Switch



WARNING

All Models Except RC27 and KFC1

When the line fuse is blown the Interlock Switch Module must be replaced.

Model RC27 and KFC1

When the line fuse is blown the Interlock Switch Assembly and Power Relay must be replaced.

Door Interlock Switch

This microwave oven has a monitoring system to assure proper operation of the safety interlock switch.

Door Interlock Switch Assembly

The interlock switch assembly located behind the cavity front, is activated by the door guide and door hook attached to the door.

The door interlock switch assembly consist of switches that control various functions within the oven. The monitor switch assures proper operation of the safety interlock system.

The primary interlock switch and secondary interlock switch control voltage to various components.

Grease Shield

Covers and protects the top antennas.



DANGER

To avoid severe personal injury or death avoid contacting any high voltage parts. The capacitors are at high voltage (4000 volt) potential and it is extremely important that they be grounded before handling.

Transformers

Two or three high voltage transformers are used in the unit. Each supplies high voltage A.C. for operation of the magnetron tubes.

High Voltage Capacitor

Doubles the A.C. output voltage from the high voltage transformer.

High Voltage Diode (Rectifier)

Is connected at the output side of the high voltage capacitor. It changes the voltage from A.C. to D.C. It passes current in one direction and blocks it in the other. Also referred to as a rectifier.

Magnetron

With a filament voltage and the high D.C. voltage from the output of the H.V. capacitor, diode junctioning the magnetron will put out an electromagnetic radio frequency of 2450 MHz to heat the load in the oven.

Thermal Protectors

All magnetrons in this oven are protected by resettable thermal cut-outs. These thermal cut-outs are mounted directly on the body of the magnetron. If one of these thermal cut-outs open, the oven will either indicate an error code in the display or operate at reduced power.

Keypads

Allows customer operation and programming of oven.

Triac

The triac is controlled (gated) by the high voltage and low voltage circuit boards. The triac controls one side of the power line going to the high voltage power transformers.

Operating Instructions

Control Panel

RC16MP, RC17, RC17SD, RC20, RC22, RC27, KFC1

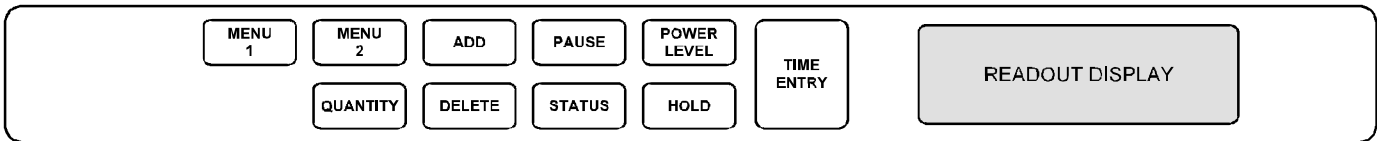

DQ22, MC22

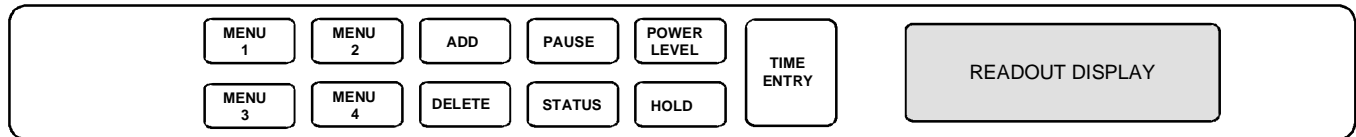

Pads

MENU 1 or MENU 2 (RC16MP, RC17, RC17SD, RC20, RC22, RC27, KFC1)

MENU 1, MENU 2, MENU 3 or MENU 4 (DQ22, MC22)

Use for independent cooking programs. For example, MENU 1 could be breakfast items; MENU 2, lunch items; MENU 3, dinner item; and MENU 4, desserts.

Numbers 1–0

Selects the desired menu item and quantity program for preset programs. Numbers are also used to enter cooking times during programming mode. Press directly on digit to activate number pads.

ADD

Use to make a change to preset number pads.

PAUSE

Use to stop microwave power halfway through cooking stage and as reminder to manipulate food.

POWER LEVEL

Use to select power level. If no power level is selected, oven operates at 100% power.

HOLD

Use to operate oven with no microwave energy for programmed time.

DELETE

Use to delete preprogrammed number pads, current heating stages and power levels.

STATUS

Use in optional programming to change options. Press to move through stages 1-4 of programming.

START

Use to save changes to permanent memory.

STOP/RESET

Exits programming mode and stops cooking during cooking cycle.

TIME ENTRY

Used to program times not in oven memory. Time entry overrides preset times.

QUANTITY (RC16MP, RC17, RC20, RC22, RC27)

Use to select a quantity greater than 1.

Readout Display

**“EOC” (End of Cycle)

Lights at end of cooking cycle.

**“PAUS” (Pause)

Lights during cooking pause.

“P”

Lights when viewing stage with an enabled pause or when entering programming mode.

“POWER”

Lights when oven is in a cook cycle.

**“COOK LEVEL”

Lights when viewing stage with reduced power or hold. Power level digit or H for hold display.

“MENU 1” or “MENU 2”

Lights active menu.

**“ITEM”

Lights when number is pressed to select item.

**“LMT” (Limit)

Flashes when either user time limit or maximum time limit is exceeded.

**“QTY” (Quantity) (DQ22 and MC22 Only)

Flashes until desired quantity is entered or 15 second time limit expires. Continuously lights during cooking cycle when quantity greater than 1 is selected.

**“STG” (Stage) indicator

Lights when multiple cooking stages exist for the selected item.

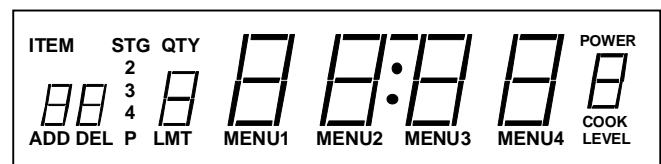
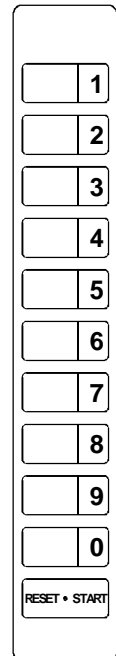

Readout Display

“RC” and KFC1 Operating Instructions

Preprogrammed Pads

Oven contains two menus with ten preset number pads each. Heating times and power levels can be adjusted to fit menu requirements. See separate programming instructions packed with oven.

Number pads come factory-set to operate at full power for the following times. *MENUS 1* and *2* pads are programmed identically at the factory.

Instructions are written for factory programmed ovens.

	RC16MP, 17, 20, 22, 27	RC22LW only
Pads	Cooking Time	Cooking Time
1	10 seconds	5 seconds
2	20 seconds	8 seconds
3	30 seconds	13 seconds
4	45 seconds	26 seconds
5	1 minute	14 seconds
6	1 1/2 minutes	7 seconds
7	2 minutes	10 seconds
8	3 minutes	No Time
9	4 minutes	No Time
0	5 minutes	No Time

On KFC1 units refer to Owners Manual for specific cooking times.

Ovens that are reprogrammed may not respond exactly as described below.

Operating Preprogrammed Pads

1. Open oven door and place food in oven. Display shows “door”. Fan and light operate.
2. Close oven door. Display shows “MENU” and “ITEM” (flashing). Press desired menu pad if different than display.

NOTE: Change quantity by following procedure in step 3. If one is desired, proceed to step 4.

3. Press *QUANTITY* pad to increase quantities. Cooking times are calculated automatically.
4. Press desired number pad and oven operates. Display shows item selected and heating time counts down. Display shows “POWER” when microwave energy is present. Display counts down cooking time.
5. Oven stops, display shows “EOC”, and signal sounds when timing sequence is finished.
6. Open oven door.

Variable Time Entry

1. Open oven door and place food in oven. Display shows “door”. Oven fan and light operate.
2. Close oven door. Display shows “MENU” and “ITEM” (flashing). Press desired menu pad if different than display.
3. Press *TIME ENTRY* pad. Display shows “0000”.
4. Press numbers to enter desired cooking time.

NOTE: Change power level by following procedure in steps 5-6. If 100 percent power is desired, proceed to step 7.

5. Press *POWER LEVEL* pad. Display shows “COOK LEVEL” and current power level.
6. Press numbers to enter desired power level. For example, press 2 pad is 20 percent power.
7. Press *START* pad and oven operates. Display shows “POWER” when microwave energy is present. If power level was programmed, display shows “COOK LEVEL”. Display counts down cooking time.
8. Oven stops and signal sounds when timing sequence is finished. Display shows “EOC”.
9. Open oven door and remove food.

Summary of Programming Multiple Stages

1. Open oven door.
2. Press pad **1** for **five** seconds.
3. Press desired **menu** pad.
4. Press desired **number** pad.
5. Enter desired cooking time.
6. Press *STATUS* pad.
7. Enter desired cooking time and power level.

NOTE: Repeat steps 6 & 7 for each stage.

8. Press *START* pad to lock new program.
9. Press *RESET* pad or close oven door to exit programming.

NOTE: The display will show the total 4 stage cooking time.

Operating Notes

If door is opened microwave energy ceases. Blower continues to operate. Close door and press *START* pad to continue oven operation and countdown timing.

Microwave energy ceases if *STOP/RESET* pad is pressed once while oven is operating, but display shows countdown time. Press *START* pad to continue oven operation and countdown timing. Oven stops and current program is cancelled if *STOP/RESET* pad is pressed twice.

If preset pad is pushed immediately after door is opened, then closed, a slight delay occurs before oven starts and timing countdown begins.

“DQ & MC” Operating Instructions

Preprogrammed Menu Items

Oven can program up to 99 separate menu items. Quantities from one to nine for each menu item may be programmed. Each item may be programmed for up to 4 independent cooking stages. The 99 programmed items may be distributed or organized into groups by assigning them to any of the 4 available menus.

Operating Preprogrammed Menu Items

1. Open oven door and place food in oven. Display shows "door". Oven fan and light operate.
2. Close oven door. Active menu item indicator lights up. "ITEM" indicator flashes.
3. Press desired menu pad if different than menu displaying.
4. Press two numbers for menu item to be cooked. For example, if menu item number 3 is selected, press 0, and 3. "ITEM" indicator lights up. "QTY" and "LMT" indicators and user defined limit flash in display. This is maximum quantity of items that can be programmed to cook in the oven at one time.
5. Press number pad to enter quantity. Quantity selected, power level for stage 1 and total cooking time for all stages display. Cooking begins immediately after quantity is entered.

NOTE: If quantity selected is not within quantity limit, signal sounds. Repeat step 4.

6. When cycle is complete, oven stops and signal sounds. "EOC" displays.
7. Open oven door and remove food.

Variable Time Entry

1. Open oven door and place food in oven. Display shows "door". Oven fan and light operate.
2. Close oven door. Display shows active menu and "ITEM".
3. Press *TIME ENTRY* pad. Display shows "0000".
4. Press numbers to enter desired cooking time.

Change power level by following procedure in steps 5–6. If 100 percent power is desired, proceed to step 7.

5. Press *POWER LEVEL* pad. Display shows "COOK LEVEL" and current power level.
6. Press numbers to enter desired power level. For example, press 2 pad for 20 percent power.
7. Press *START* pad and oven operates. Display shows "POWER" when microwave energy is present. If power level was programmed, display shows "COOK LEVEL". Display counts down cooking time.
8. Oven stops and signals when timing sequence is finished. Display shows "EOC".
9. Open oven door and remove food.

Operating Notes

If door is opened, oven energy ceases. Blower continues to operate. Close door and press *START* to continue oven operation and countdown timing.

If *RESET* is pressed once while oven is operating, oven energy ceases, but countdown time remains in display. Press *START* to continue oven operation and countdown timing. If *RESET* is pressed twice, oven stops and current program cancels.

When unit is plugged in or repowered after the loss of electricity, it will take several seconds before dashes and menu indicator display. Once displayed, unit is operational.

“DQ & MC” Programming Instructions

Programming Menu Items

1. Open oven door. Display shows "door". If door is closed or RESET is pressed before finishing programming sequence, oven exits programming mode.
2. Press and hold pad number 1 for five seconds. After five seconds, signal sounds. "P" and active menu display.
3. Press ADD to begin programming.
4. Press desired menu pad to be preprogrammed, if not displaying. "MENU" indicator displays.
5. Press two number pads to be programmed. "QTY" (quantity) and "LIMIT" indicators and the current quantity limit flash.

NOTE: To change quantity limit:

- Press hidden enable pad. Locate hidden enable pad to the immediate left and slightly down from the MENU 1 pad. Signal sounds.
 - Press number pad to enter quantity limit. Maximum quantity limit for each menu item is nine.
 - Press START to save new quantity limit.
6. Press number pad to enter quantity. Quantity selected, program time and power level for stage 1 display. "STG" (stage) indicator and stage numbers with nonzero times also light up if multiple stages exist.

NOTE: If quantity selected is not within quantity limit, signal sounds. Repeat step 5.

7. Press numbers to enter desired cooking time.
8. Press POWER LEVEL. "COOK LEVEL" indicator and current power level display.
9. Press numbers to enter power level if power level other than 100% is desired. New power level displays. For example, press pad number 2 for 20 percent power.
10. Press START pad to lock new heating time and power level in oven memory. Display shows "P".
11. Press RESET pad or close oven door to exit programming mode.

Programming Multiple Stages

1. Complete steps 1 - 9 of "Programming Menu Items".
2. Press *STATUS* pad to move through stages from lowest to highest (1 to 4). Display shows "PX" for one second followed by time and power level for selected stage. "P" represents program, "X" represents stage 1,2,3 or 4.
3. Press number pads to enter desired cooking time and power level.
4. Repeat steps 3 - 4 for additional stages.
5. Complete steps 10 - 11 of "Programming Menu Items".

Specialized Programming

[QTY] Quantity (RC16MP, RC17, RC17SD, RC20, RC22, RC27, KFC1)

1. Open oven door and place food in oven.
2. Close oven door.
3. Press QUANTITY pad.
 - Oven is always set for QTY1
 - Press QTY once QTY2
 - Press QTY twice QTY3
 - Press QTY three times QTY4
4. Press START pad.

NOTE: The oven will automatically adjust the time setting for the QTY. programmed.

[LMT] Limit (All Models)

Maximum amount of time a customer can program a pad (number).

When time LMT is changed the time will change for all pads (numbers) in MENU1 or MENU2.

1. Enter program mode.
2. Press hidden enable pad.
3. Press MENU1 or MENU2.

NOTE: Display will show current maximum time [LMT].

4. Enter new time LMT.
5. Press MENU1 or MENU2.
6. Close door or press reset pad.
 - If a time higher than the max. time limit is entered, display will flash LMT and maximum time. Display will then reset to "0000".
 - LMT does not affect time entry operation.

PAUS (Pause) (All Models)

Used to stop microwave power halfway through the cooking cycle as a reminder to manipulate food.

Programming PAUS

1. Open oven door.
2. Press pad 1 for five seconds to enter programming mode.
3. Press the desired menu pad (exp: MENU1).
4. Press the desired number pad needing reprogrammed (exp: pad number 1) .
5. Press POWER LEVEL pad if power level other than 100% is desired. Enter desired power level. If 100% power is desired proceed to step 6.
6. Enter desired cook time.
7. Press Pause pad.
8. Press start.
9. Press reset pad or close oven door to exit programming mode.

Using PAUS Function

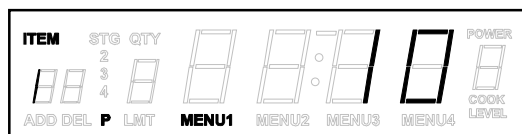

1. Open door, place food in oven.
2. Close oven door.
3. Press desired menu pad (exp: MENU1).
4. Press desired number pad (exp: pad number 1).
5. Oven starts. Display counts down.
6. Oven stops halfway through the cook cycle (oven displays PAUS and beeps 3 times).

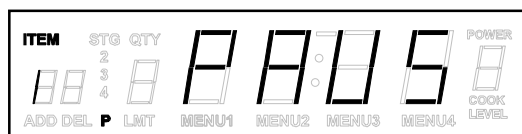

7. Open door and manipulate food.
8. Close door.

Option Programs (All Models Except WDYRC)

1. Open oven door.
2. Press 1 pad for five seconds.

RC Models

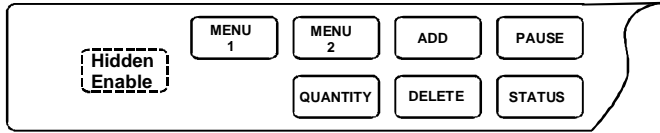

DQ & MC Models

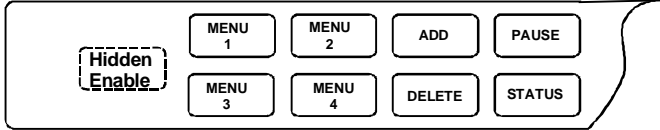

3. Press hidden enable pad.

NOTE: Display will indicate option code. Example:
OP:11

4. Press **START** pad to view **active** option codes.
5. Press **STATUS** pad to **change** option codes.
6. Repeat steps 4 and 5 to change additional options.
7. Press hidden enable pad to return to programming mode.
8. Press **RESET** pad or close oven door.

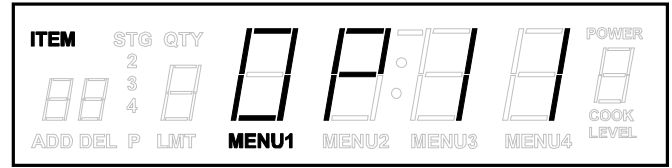

Option	Description	Code
End of cycle signal tone	Off	OP:10
	Continuous tone*	OP:11
	5 continuous tones	OP:12
	5 tones, 5 cycles	OP:13
Tone when pad is pressed	Off	OP:20
	On*	OP:21
Control panel resets when door is opened	Off*	OP:30
	On	OP:31
End of cycle signal volume	Loud*	OP:40
	Medium	OP:41
User time limit	Off	OP:50
	On*	OP:51

* AS SHIPPED FROM FACTORY

WDYRC Operating Instructions

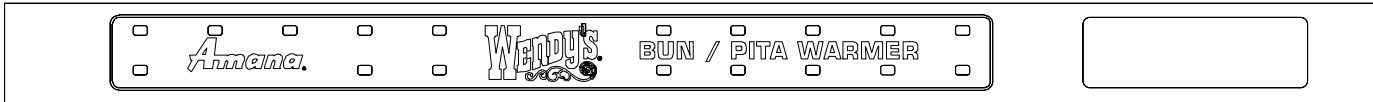

Display

Many items in display can be seen but will not glow.



88:88	Counts down heating time.
"EOC" (End of Cycle)	Lights at end of heating cycle. Remains in display until door is opened.
"POWER"	Lights when microwave power is supplied to oven cavity.

Pads Description

<i>START</i>	Begins heating cycle. If <i>START</i> is pressed while heating cycle is paused, new heating cycle begins.
<i>RESTART</i>	If door is opened and heating is paused, <i>RESTART</i> pad resumes paused heating cycle.

Pad	Time	Power Level
1 BAG PITA	25 sec.	100%
2 BAG PITA	50 sec.	100%
1 DOZ BUN	30 sec.	100%
2 DOZ BUN	1 min.	100%

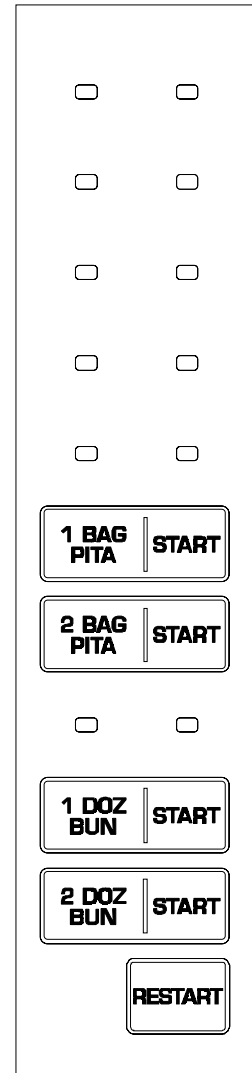

Connecting Power

When unit is plugged in or powered after the loss of electricity, it will take several seconds before dashes and menu indicator display. Once displayed, unit is operational.

Interrupting Operation

Open oven door to interrupt operation. Oven fan continues to operate. Close door and press *RESTART* pad to resume oven operation.

Canceling Mistakes

If oven door is open and time shows in display, close oven door and press *RESTART* pad to resume heating cycle or a *START* to begin new heating cycle. If heating cycle is paused and not restarted, remaining time clears in 15 seconds. Oven door must be opened and closed before starting a new heating cycle.

Heating with Preprogrammed Pads

Oven has 4 preprogrammed pads.

- Open oven door and place food in oven. Display shows "door".
 - Fan and light operate.
- Close oven door. Display shows "MENU" and "ITEM".
 - If oven display does not show "ITEM", pads do not accept entries. Open and close oven door to activate pads.
- Press desired a *START* pad and oven operates.
 - Heating time counts down.
 - Display shows "POWER" when microwave energy is present.
- Oven stops and signal sounds when timing sequence is finished.
 - Display shows "EOC".
- Open oven door.







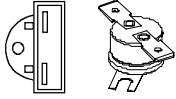

Wendy's Recommended Performance Test
See "Owner's Manual".

Component Testing Procedures

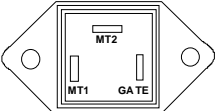
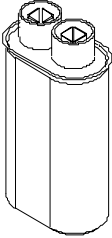

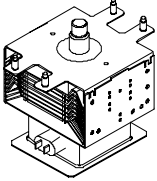
WARNING

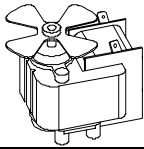
To avoid risk of electrical shock, personal injury, or death, disconnect power to oven and discharge capacitor before servicing, unless testing requires it.

Illustration	Component	Test	Results
	Thermal Cutout B5684106 _____ B5795306 _____ B5684118 _____	Disconnect all wires from TCO. Measure resistance across terminals. Magnetron TCO (.250" terminals) Cavity TCO Control TCO (.187" terminals)	Open at 280°F and closed at 180°F Opens at 262°F (128°C) Open at 280°F and closed at 180°F
	Diode	Discharge Capacitors Remove diode lead from capacitor and connect ohmmeter. Reverse leads for second test.	Infinite resistance should be measured in one direction and 50KΩ or more in the opposite direction. NOTE: Analog meter must contain a battery of 6 volts minimum.
	Triac	Disconnect wires to triac. Measure resistance from: MT1 to MT2 MT1 to Gate MT2 to Gate All terminals to ground	Caution - Do not operate oven with wire to terminal MT2 removed. Infinite Ω Approximately 40 Ω or more Infinite Ω Infinite Ω
	Capacitor	Discharge Capacitors Remove wires from capacitor terminals and connect ohmmeter, set on highest resistance scale to terminals. Also check between each terminal and capacitor case.	Between Terminals: Meter should momentarily deflect towards zero then return to over 5 MΩ. IF no deflection occurs, or if continuous deflection occurs, replace capacitor. Terminal to Case: Infinite resistance
	Snubber Assembly	Disconnect wires to snubber. Measure resistance across terminals.	Infinite Ω
	Magnetron	Discharge Capacitors Remove wires from magnetron and connect ohmmeter to terminals. Also check between each terminal and ground.	Between Terminals: Less than 1 Ω Each terminal to ground measures Infinite resistance. Note: This test is not conclusive. If oven does not heat and all other components test good replace the magnetron and re-test.
	Antenna motor	Remove all wires from terminals. Measure resistance from: Terminal to terminal	Approximately 10,000 Ω
	Blower Motor	Remove all wires from motor. Measure resistance across coil.	Approximately 34 Ω
	Lamp 240 VAC 40 Watts	Measure resistance	Approximately 120 Ω

Component Testing Procedures

⚠ WARNING

To avoid risk of electrical shock, personal injury, or death, disconnect power to oven and discharge capacitor before servicing, unless testing requires it.

Illustration	Component	Test	Results
	Transformer 	Discharge Capacitors Remove all wires from terminals. Measure resistance from: Terminal 230 (HI) to Com Terminal 208 (LO) to Com Terminal 5 to 6 Terminal 4 to Ground screw on transformer Terminal 4 to any other terminal	1 Ω 1 Ω <1 Ω 65–80 Ω Infinite resistance should be indicated, if not replace transformer.
	Auto Transformer 	Discharge Capacitors Remove all wires from terminals. Measure resistance from: 230 to 0 208 to 0	44 Ω 43 Ω
	Interlock switch Type 1 Door Open Dummy 1 Secondary 2 Logic/Primary 3 Monitor 4 5 6 7 8 9	Disconnect wires to switch With door open measure resistance from: Terminal 2 to terminal 3 Terminal 4 to terminal 5 Terminal 7 to terminal 8 With door closed measure resistance from: Terminal 2 to terminal 3 Terminal 4 to terminal 5 Terminal 7 to terminal 8	Infinite Ω Infinite Ω Indicates continuity Indicates continuity Indicates continuity Infinite Ω
<p>For larger illustration see page 33 in Disassembly Procedures</p>	Interlock switch Type 2	Disconnect wires to switch With door open measure resistance from: COM to N.O.—Secondary COM to N.O.—Primary COM to N.C.—Monitor With door closed measure resistance from: COM to N.O.—Secondary COM to N.O.—Primary COM to N.C.—Monitor	Infinite Ω Infinite Ω Indicates continuity Indicates continuity Indicates continuity Infinite Ω
	Interlock switch Type 3 Door closed 2 —●— 3 5 —●— 4 7 —●— 8	Disconnect wires to switch. With door open measure resistance from: Terminal 2 to 3 Secondary Terminal 4 to 5 Primary Terminal 7 to 8 Monitor With door closed measure resistance from: Terminal 2 to 3 Secondary Terminal 4 to 5 Primary Terminal 7 to 8 Monitor	Infinite Ω Infinite Ω Indicates continuity Indicates continuity Indicates continuity Infinite Ω

Component Testing Procedures

⚠ WARNING

To avoid risk of electrical shock, personal injury, or death, disconnect power to oven and discharge capacitor before servicing, unless testing requires it.

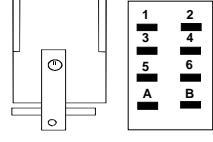
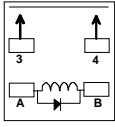
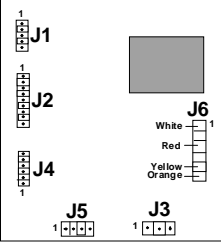
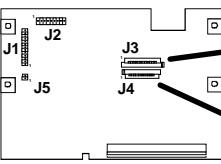
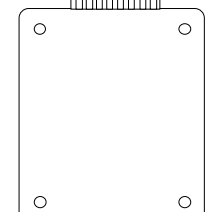
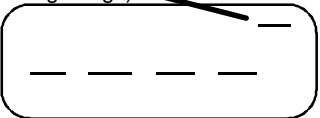
Illustration	Component	Test	Results
	Relay 	Remove all wires from relay. Measure resistance: A to B (coil) 3 to 4 (contacts) With 12 VDC across the coil (A to B) Measure resistance: 3 to 4 (contacts)	Approximately 120 Ω Infinite Ω 0 Ω
	High voltage board J6 connections 1-White 2-Open 3-Red 4-Open 5-Yellow 6-Orange	Connector Plugged-In J2—Pin 5 (violet) to ground J2—Pin 6 J2—Pin 7 (blue) to ground J6—Pin 6 (orange) to Pin 1 (white) J6—Pin 5 (yellow) to Pin 1 (white) J6—Pin 1 (white) to Pin 3 (red)	-27 VDC Ground +18 VDC 230 volts—output to blower and antenna motors when line voltage is 230 V 208 volts—output to auto transformer for blower and antenna motors when line voltage is 208 V Line voltage
	Low voltage board J3 connector is for side keypad ribbon. J4 connector is for top keypad ribbon.	Connector Plugged-In J2—Pin 5 (violet) to ground J2—Pin 6 J2—Pin 7 (blue) to ground J3 connector is for side keypad ribbon. J4 connector is for top keypad ribbon.	-27 VDC Ground +18 VDC
	Extended memory board MC and DQ only	1) Unplug oven for 1 minute. 2) Close oven door. 3) Plug oven in.	This dash must be lit (top segment of far right digit). 
Wire Harness		Test continuity of wires.	Indicates continuity

Component Testing Procedures

⚠ WARNING

To avoid risk of electrical shock, personal injury, or death, disconnect power to oven and discharge capacitor before servicing, unless testing requires it.

All models except WDYRC

Top Keypad



To test keypad for proper operation:

1. Identify ribbon traces for selected keypad using chart.
2. Resistance between selected traces = 0 ohms.
3. Pressing keypad, resistance between selected traces is less than 60 ohms.

Keypad	Switch	Ribbon Trace	Ribbon Trace	Keypad	Switch	Ribbon Trace	Ribbon Trace
Menu 4/Quantity	S1	11	10	Power Level	S19	9	5
Menu 3	S3	11	8	Time Entry	S22	8	7
Pause	S13	10	5	Hold	S27	7	6
Delete	S14	10	4	Enable	S28	7	5
Status	S15	10	3	Add	S36	4	3
Menu 1	S16	9	8				
Menu 2	S17	9	7				

J4 - Place split in ribbon cable to the right as facing the front of the unit.

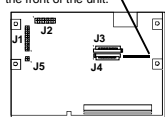
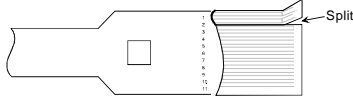
L.V. Board Ribbon Cable

Side Keypad

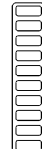

To test keypad for proper operation:

1. Identify ribbon traces for selected keypad using chart.
2. Resistance between selected traces = 0 ohms.
3. Pressing keypad, resistance between selected traces is less than 60 ohms.

Keypad	Switch	Ribbon Trace	Ribbon Trace	Keypad	Switch	Ribbon Trace	Ribbon Trace
Stop/Reset	S18	3	4	7	S39	6	10
0	S25	4	5	4	S40	7	8
Start	S30	4	10	5	S42	7	10
8	S31	5	6	2	S43	8	9
9	S35	5	10	3	S44	8	10
6	S36	6	7	1	S45	9	10

J3 - Place split in ribbon cable to the right as facing the front of the unit.

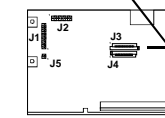
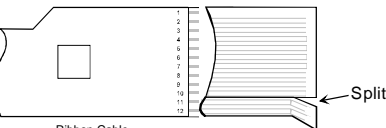
L.V. Board Ribbon Cable

WDYRC

Top Keypad

To test keypad for proper operation:

1. Identify ribbon traces for selected keypad using chart.
2. Resistance between selected traces = 0 ohms.
3. Pressing keypad, resistance between selected traces is less than 40 ohms.

J4 - Place split in ribbon cable to the right as facing the front of the unit.

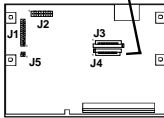
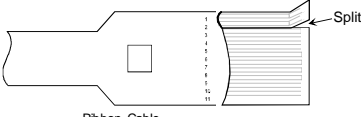
L.V. Board Ribbon Cable

Switch	Ribbon Trace	Ribbon Trace	Switch	Ribbon Trace	Ribbon Trace
T-1	10	4	T-2	8	7



T-1 T-2

Side Keypad

To test keypad for proper operation:

1. Identify ribbon traces for selected keypad using chart.
2. Resistance between selected traces = 0 ohms.
3. Pressing keypad, resistance between selected traces is less than 40 ohms.

J3 - Place split in ribbon cable to the right as facing the front of the unit.

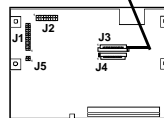
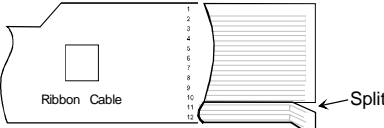
L.V. Board Ribbon Cable

Switch	Ribbon Trace	Ribbon Trace
S1	9	10
S2	8	9
S3	8	10
S4	7	8
S5	7	10
S6	6	7
S7	6	10
S8	5	6
S9	5	10
S10	4	5
S11	4	10
S12	3	4

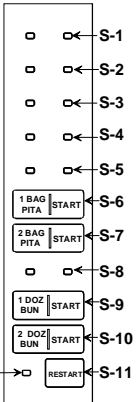

S-1 S-11

Display Diagnostics

CAUTION

All repairs as described in this troubleshooting guide section are to be performed only after the caution procedures one through seven listed below have been followed.

1. Check grounding before checking for trouble.
2. Be careful of the high voltage circuit.
3. Discharge high voltage capacitor.
4. When checking the continuity of the switches or the high voltage transformer, disconnect one lead wire from these parts and then check continuity with the AC plug removed. To do otherwise may result in a false reading or damage to your meter.
5. Do not touch any parts of the circuitry on the P.C. Board circuit since static electric discharge may damage this control panel. Always touch yourself to ground while working on this panel to discharge any static charge in your body.
6. 208/230 VAC is present in the high voltage circuit board, terminals of power relay and primary circuit of low voltage transformer.
7. When troubleshooting, be cautious of possible electrical hazard.

Service Codes

During operation, the display may show the following service codes:

- NOTE:**
1. Always unplug the oven for one minute. Replug oven in and check for error codes.
 2. Check oven for proper operation.

Service Codes	Explanation
S 1	Watchdog - Membrane Touch Panel
C S	Current Sense
F L	Low Current
F H	High Current
P L	Power level
P C E 1	Checksum - Check Permanent Memory
P C E 5	Communication Failure
P C E 6	Communication Failure
H O T	Magnetron Overheating
H I	High Line Voltage
L O	Low Line Voltage

Display Diagnostics

S1 Watchdog - Membrane Touch Panel

Watchdog circuit verifies touch panel entry.

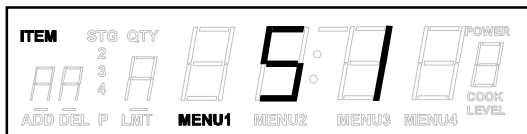

Possible Causes:

1. Shorted top touch panel.
2. Shorted side touch panel.

Testing

1. Disconnect power from oven.
2. Disconnect one touch panel ribbon cable from the L.V. circuit board.
3. Plug oven in, open and close door to activate oven.
4. Wait approximately 60 seconds. If "S1" does not appear in display, replace the disconnected touch panel.
5. If "S1" re-appears in display, disconnect the other touch panel and repeat steps 3 and 4.

HOT Magnetron Overheating

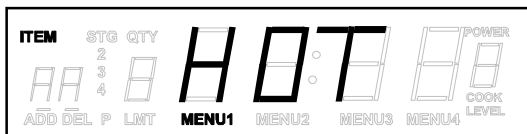

When "HOT" is displayed, the blower motor should be operating.

Possible Causes:

1. Restricted air filter.
2. High ambient temperature.
3. Oven operated empty or with light loads.
4. Open control TCO.
5. Inoperative blower motor / wheel.
6. Open/loose TCO ground wire.
7. Open/loose E1 ground wire at H.V. board.
8. Inoperative high voltage board.

CS Current Sense

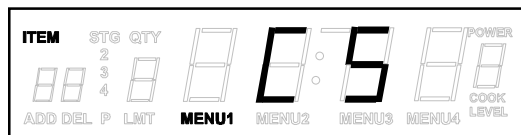

Current Sense – Indicates control is sensing low current (Amp) draw. Check components which would allow unit to run but produce no heat or low heat. Current sense circuit is active only when using pre-programmed pads. Time Entry feature will by-pass current sense circuit. Red wire from cavity T.C.O. must be routed through current sense loop on H.V. Board.

Possible Causes:

1. Interlock switch (contacts 2 & 3).
2. Open thermal cut-out (magnetron).
3. Open/loose wire.
4. Power relay.
5. H.V. Board.
6. Magnetron.
7. Diode.
8. Capacitor.
9. Transformer.
10. Triac.

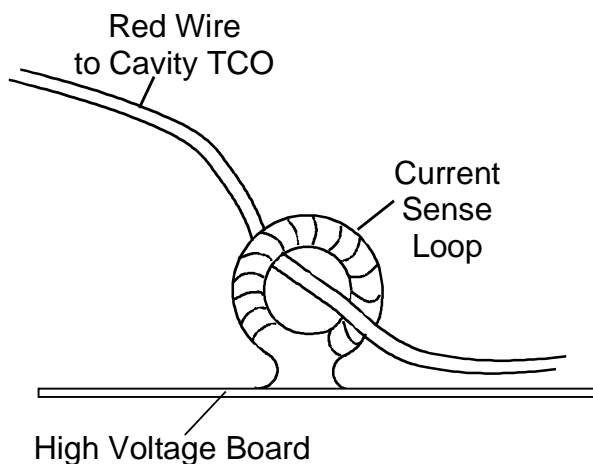

Display Diagnostics

PCE1 Checksum

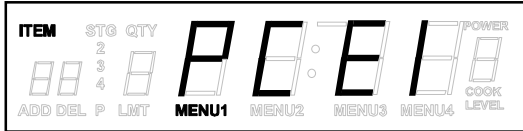

NOTE: Before scheduling service for this complaint, instruct customer to unplug oven for one minute, reconnect, and retest. If unit operates properly, no further service is required.

If this error code does not disappear possible causes are:

1. Inoperative low voltage board.

PCE5 Communication Failure

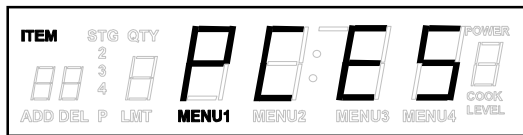

NOTE: Before scheduling service for this complaint, instruct customer to unplug oven for one minute, reconnect, and retest. If unit operates properly, no further service is required.

If this error code does not disappear possible causes are:

1. Broken or improper wire connection between high voltage board and low voltage board.
2. Inoperative cable between low voltage board and extended memory board.
3. Inoperative high voltage board.
4. Inoperative low voltage board.
5. Inoperative extended memory board.

PCE6 Communication Failure

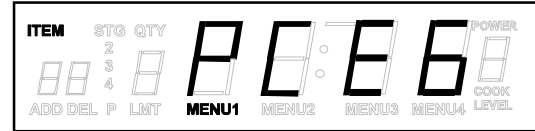

NOTE: Before scheduling service for this complaint, instruct customer to unplug oven for one minute, reconnect, and retest. If unit operates properly, no further service is required.

If this error code does not disappear possible causes are:

1. Broken or improper wire connection between high voltage board and low voltage board.
2. Inoperative cable between low voltage board and extended memory board.
3. Inoperative high voltage board.
4. Inoperative low voltage board.
5. Inoperative extended memory board.

HI High Line Voltage

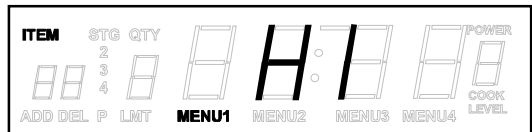

1. Input voltage over 270 VAC.
2. Inoperative high voltage board.

LO Low Line Voltage



1. Input voltage less than 185 VAC.
2. Inoperative low voltage board.

Service Test – All Models Except WDYRC

For WDYRC service test information, refer to RT2230008 Technical Sheet

The high voltage portion of these models contain multiple H.V. systems.

Each H.V. System contains the following:

- 1 Magnetron
- 1 H.V. Transformer
- 1 Capacitor
- 1 Diode
- 1 Triac
- Connecting wiring

Each H.V. system may be operated independently for diagnostic purposes.

During this test the display will show a number (usually between 8 and 24 for each H.V. system operating) signifying some current draw of the unit.

This is *not* showing actual amperage, but a current reference.

Accessing Service Test Mode

1. Open door and place 1000 ml water load in oven.

NOTE: Perform the following 4 steps within **15 seconds** or this procedure will be cancelled.

2. Press **DELETE**,
3. Press **1, 3, 5, 7**,
4. Close door.
5. Press **DELETE**.

NOTE: Pressing **RESET** at any time will cause the control to exit the Service Test.

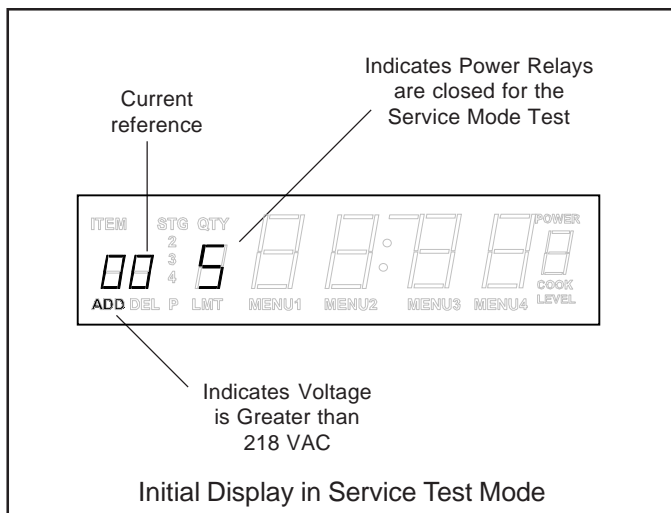

H.V. System Test

When Service Test Mode has been accessed, the H.V. system test must be started within **60 seconds** to assure accurate test readings. **The door must be closed.**

1. Press pad **1** to activate H.V. System # 1.
 - The triac drive will be activated after a minimum of 100 milliseconds.
 - A 62 seconds full power cook cycle will begin for the selected H.V. system.

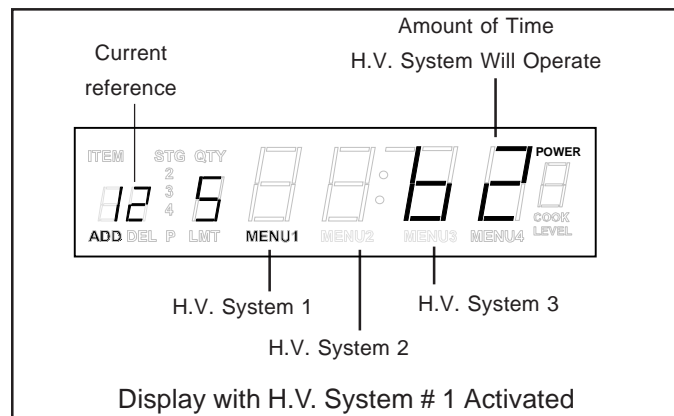

2. Press pad **1** again to de-activate H.V. System # 1.
3. Press pad **2** to activate H.V. System # 2.
4. Press pad **2** again to de-activate H.V. System # 2.
5. Press pad **3** to activate H.V. System # 3.
6. Press pad **3** again to de-activate H.V. System # 3.

Diagnosing Individual H.V. System Components

If the service test indicates a non-functional H.V. system, proceed as follows:

1. Identify the number of the H.V. system that is not functioning and the corresponding magnetron location.
 - MENU 1 = Bottom magnetron
 - MENU 2 = Top rear magnetron
 - MENU 3 = Top front magnetron

NOTE: Component numbering in the wiring / schematic diagrams may not match the numbering of MENU 1, MENU 2 or MENU 3 display indicators.

2. Using the wiring diagram, identify the location of components numbered the same as the non-functioning magnetron. H.V. components with the same number are part of the same H.V. system.

Service Test

Multiple H.V. System Testing

Two or three H.V. Systems may be tested together. Below are display samples showing different combinations.

NOTE: This is *not* showing actual amperage, but a current reference.

Example: If one H.V. System is showing a current reading of 15, then any two H.V. Systems may have a reading of about 30, and all three H.V. Systems may have a reading of about 45. Current reference readings will vary.

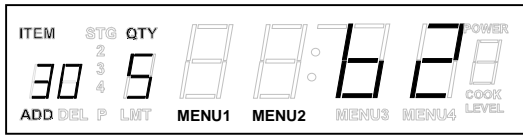

H.V. System 1 & 2

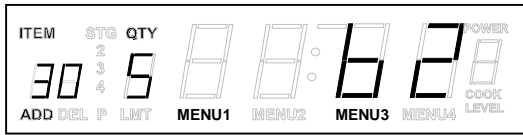

H.V. System 1 & 3

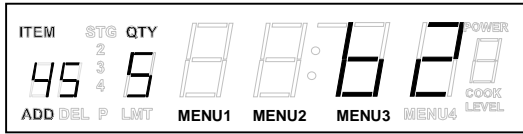

H.V. System 1, 2, & 3

Door Cycles and Magnetron Hours

- Press *TIME ENTRY* pad once for door cycles.

NOTE: Door cycle counter advances one number for every 100 door cycles.

Example:

Display reads 156 x 100 = 15,600 (Actual door cycles)

- Press *TIME ENTRY* pad again for H.V. section # 1 hours.
- Press *TIME ENTRY* pad again for H.V. section # 2 hours.
- Press *TIME ENTRY* pad again for H.V. section # 3 hours.
- Press *TIME ENTRY* pad again reverts to door cycles.

Door Cycles

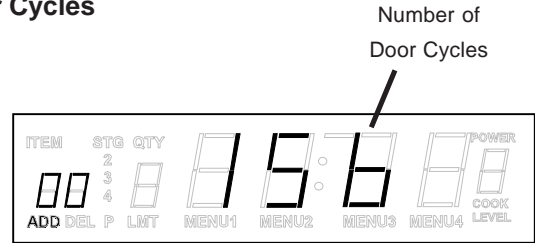

Display

Magnetron Hours

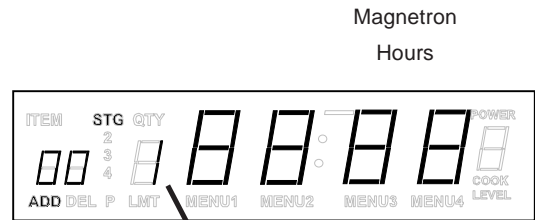

Indicates Operating H.V. System Display

Power Test (Traditional 1 Liter Test)

Test equipment required is Amana power test kit R0157397 (Fahrenheit), or Menumaster power test kit M95D5 (Celsius).

1. Fill the plastic container to the bottom of the 1000 ml. line with cool tap water.
2. Using the thermometer; Fahrenheit or Celsius, stir the water, measure and record the water temperature.

Initial water temperature should be approximately 60°F (20°C).

3. Place container on the center of the oven shelf and heat the water for 33 seconds for units more than 1550 Watts cooking power or 63 seconds for units less than 1550 Watts cooking power.

NOTE: Use a watch second hand, not the oven timer.

4. Stir the water, measure and record the temperature of the water after heating time is complete.
5. Subtract the starting water temperature (Step 2), from the ending water temperature (Step 4) to obtain the temperature rise.
6. See the Temperature Chart provided below.

NOTE: Always perform power test three times for accuracy, changing the water after each test is performed.

NOTE: Variation or errors in the test procedure will cause a variance in the temperature rise indication. Additional power tests should be made if temperature rise appears marginal.

NOTE: Low line voltage may cause lower power output (temperature rise).

Temperature Chart

THIRTY THREE SECONDS run time chart for units more than 1550 watts cooking power.

ΔT (°F)	Cooking Power Output	ΔT (°F)	Cooking Power Output
20	1550	28	2170
21	1627	29	2247
22	1705	30	2325
23	1782	31	2402
24	1860	32	2480
25	1937	33	2557
26	2015	34	2635
27	2092	35	2712

ΔT (°C)	Cooking Power Output	ΔT (°C)	Cooking Power Output
11	1540	15.5	2170
11.5	1610	16	2240
12	1680	16.5	2310
12.5	1750	17	2380
13	1820	17.5	2450
13.5	1890	18	2520
14	1960	18.5	2590
14.5	2030	19	2660
15	2100	19.5	2730

SIXTY-THREE SECONDS run time chart for units less than 1550 watts cooking power.

ΔT (°F)	Cooking Power Output	ΔT (°F)	Cooking Power Output
12	464	20	775
13	504	21	814
14	542	22	852
15	581	23	891
16	620	24	930
17	659	25	969
18	697	26	1007
19	736		

ΔT (°C)	Cooking Power Output	ΔT (°C)	Cooking Power Output
7	490	11	770
8	560	12	840
9	630	13	910
10	700	14	980

Troubleshooting

Initial Power Up

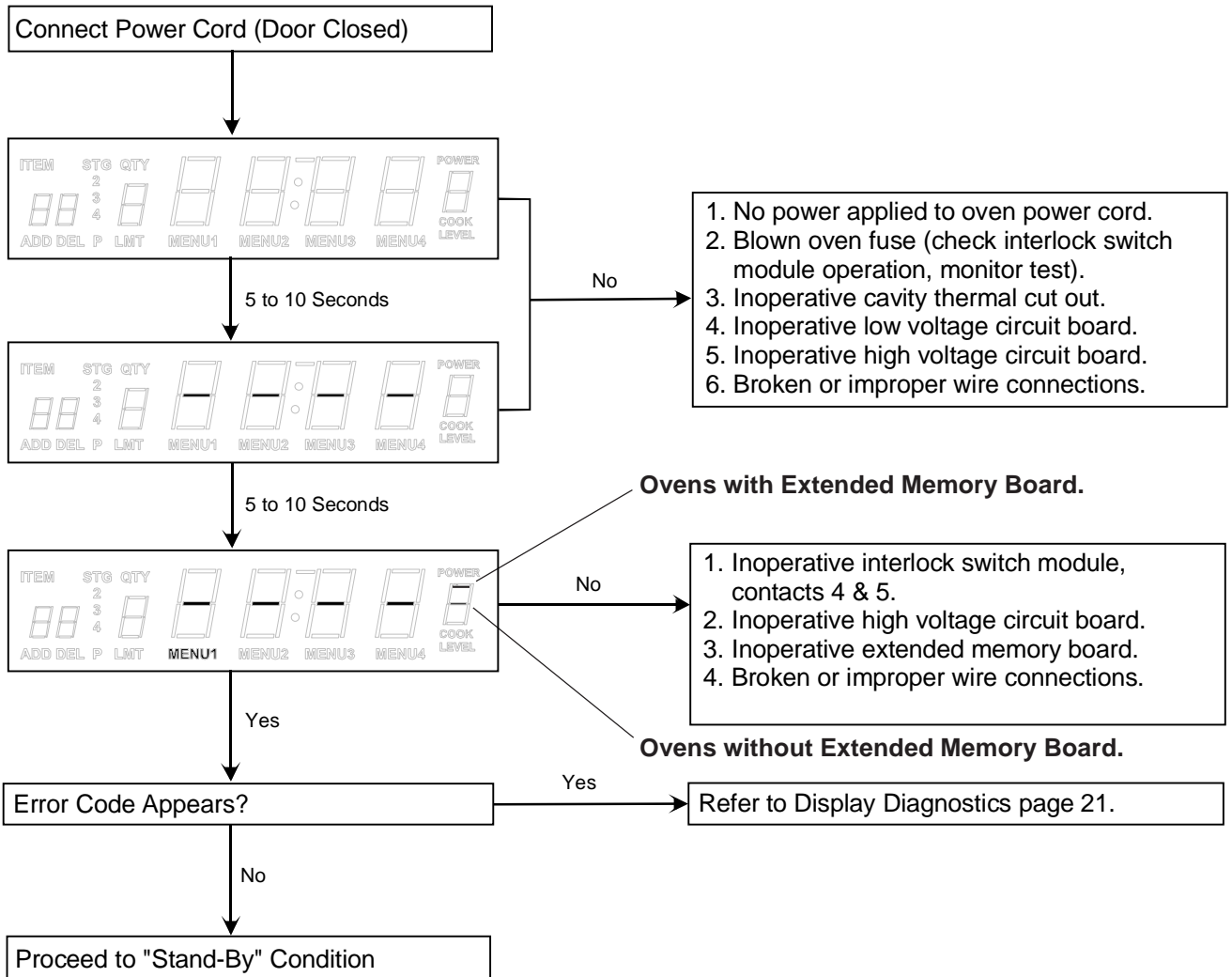

Troubleshooting

Stand By Condition

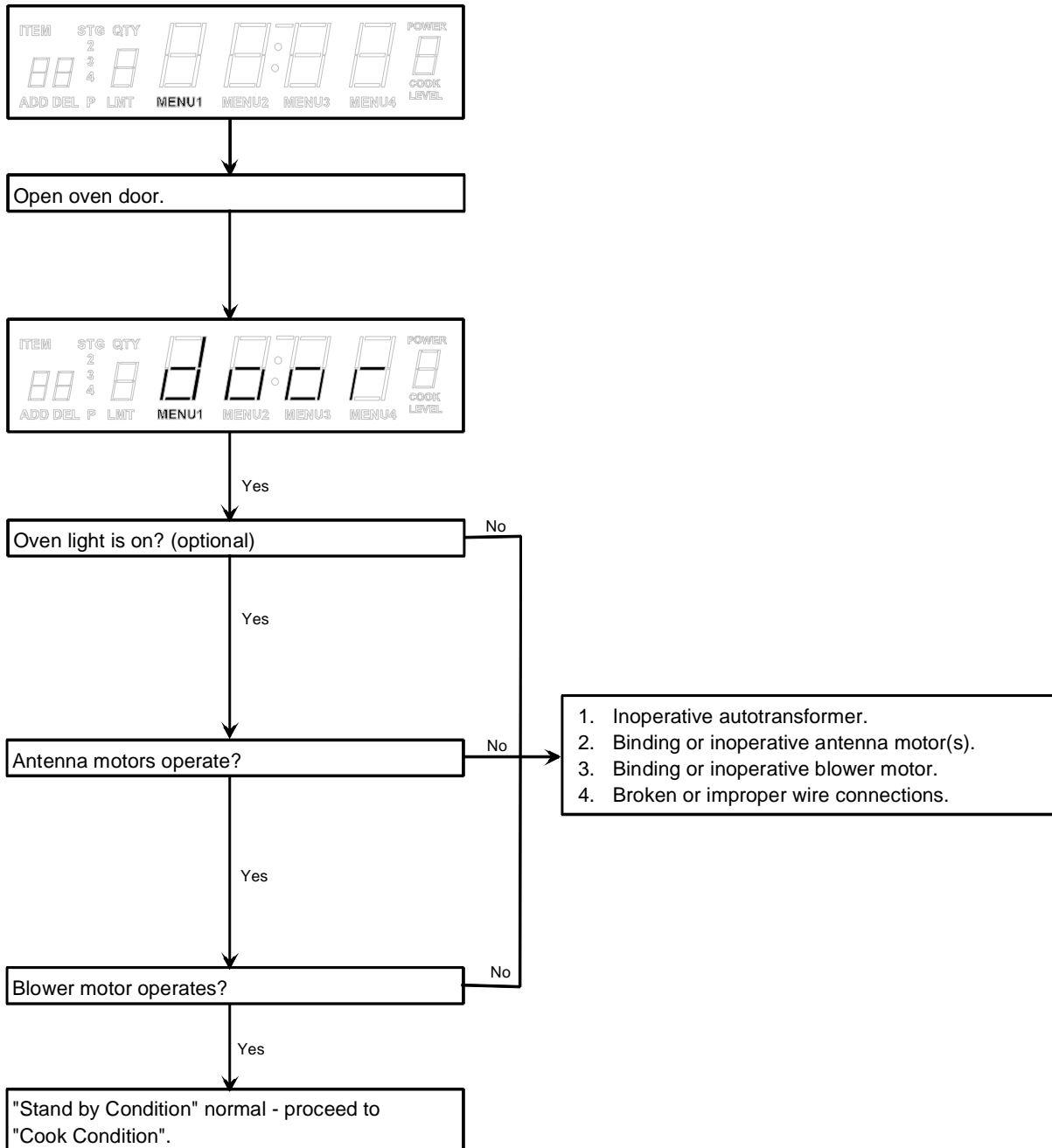

Troubleshooting

Cook Condition

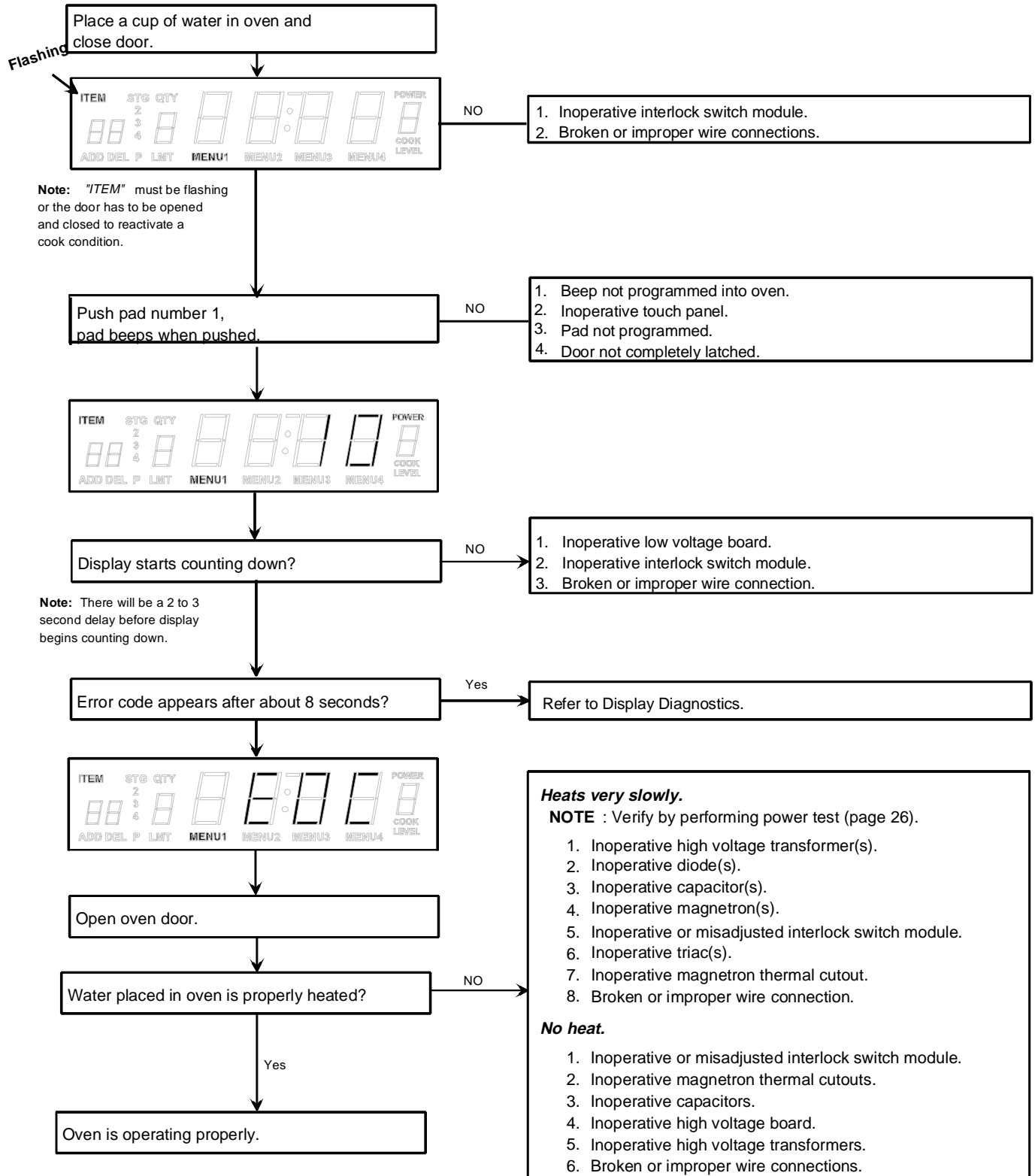

Disassembly



WARNING

To avoid the risk of electrical shock, personal injury, or death, disconnect power to oven and discharge capacitors before following any disassembly procedure.

Latch Handle

The latch handle is removed by loosening the two set screws (3/32 inch allen screws), one located to the left of the latch and one located on the bottom of the latch handle.

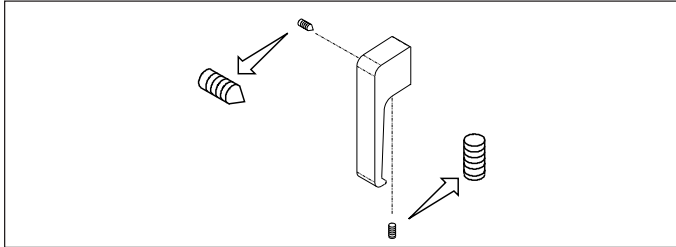

NOTE: If the set screws are removed, the set screw with the flat end must be used in the bottom of the latch handle.

NOTE: When replacing door handle, tighten side set screw first.

Inner Door Ring Assembly

1. Remove latch handle.
2. Remove outer door assembly.
3. Remove 5 hinge screws securing inner door ring assembly.

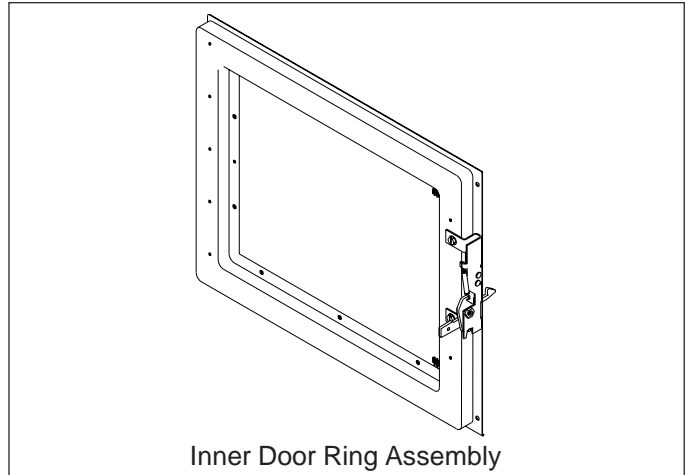

Inner Door Ring Assembly

Door

1. Remove latch handle.
2. Remove outer door ring assembly from inner door ring by removing 10 y-drive screws.

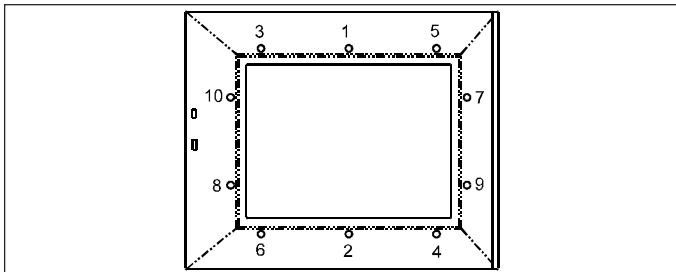

NOTE: When reinstalling outer door, tighten screws in pattern as shown above.

The door ring assembly consists of the inner door ring, the inner door panel, and latch assembly. These components are available only as a complete assembly.

Hinge

1. Remove outer case.
2. Remove door latch handle.
3. Remove outer door assembly.
4. Remove nine hinge mounting screws from hinge (five on front, 4 on side).

NOTE: Reinstall foam gasket on side of hinge when reinstalling.

5. When reinstalling hinge mounting screws, keep the side screws loose and the front screws tight, close door, press door against oven on the hinge side and tighten side hinge mounting screws in the sequence shown below.

Outer Door

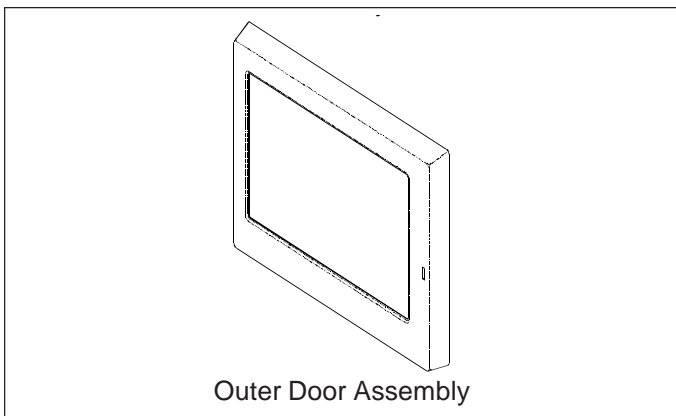

Outer Door Assembly

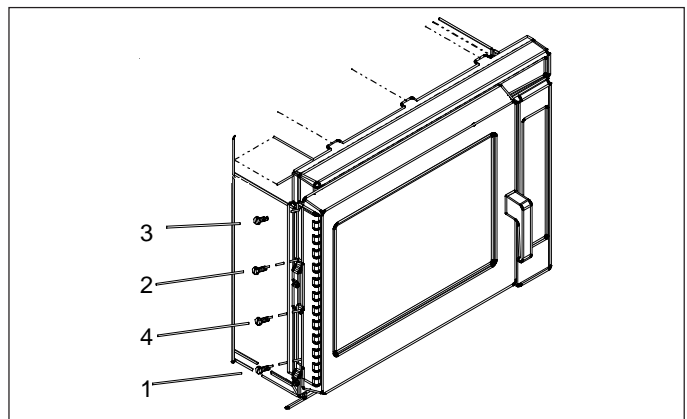

The outer door assembly consists of the outer door, outer window, and lens retainer. These components are available only as a complete assembly.

Disassembly



WARNING

To avoid the risk of electrical shock, personal injury, or death, disconnect power to oven and discharge capacitors before following any disassembly procedure.

Bottom Shelf

NOTE: The tray is sealed in place with Silicone Rubber.

This type of sealant releases acetic acid and needs curing. The unit should not be used for minimum of one hour after application.

1. Unplug oven from outlet.
2. Open door and using a thin bladed knife, cut seal along edges and remove pieces from unit.
3. Remove any sealant residue and thoroughly clean sump area using a mild detergent.
4. Clean oven cavity bottom where new RTV sealant will make contact using mineral spirits or any nonflammable de-greasing solvent.

NOTE: Detergents, soap, and water are not sufficient to remove oil and grease.

5. Place new tray into unit and seal in place.
6. Allow RTV sealant to cure one hour before using.

Grease Shield

1. Unplug oven before removing grease shield to stop antenna from rotating.
2. Remove shield by placing thumbs in front of shield. Press firmly toward back and carefully lower front of shield away from antenna. Pull shield forward, out of back slots and out of oven.
3. Replace grease shield by fitting tabs into slots at top of oven back. Lift and press front of shield until shield snaps into place.

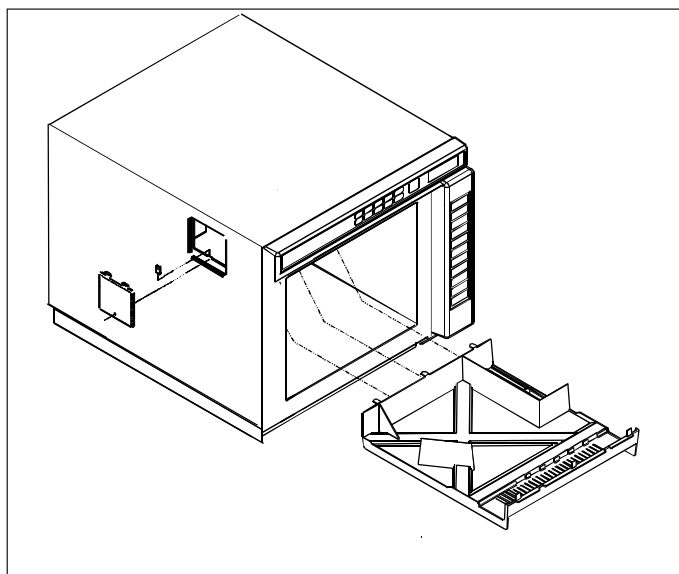

Outer Case

1. Remove screws in side and back.
2. Slide outer case back and lift off.

Top Keypad Assembly

1. Remove outer case.
2. Remove ribbon cable from low voltage circuit board.
3. Remove screws and lift out.

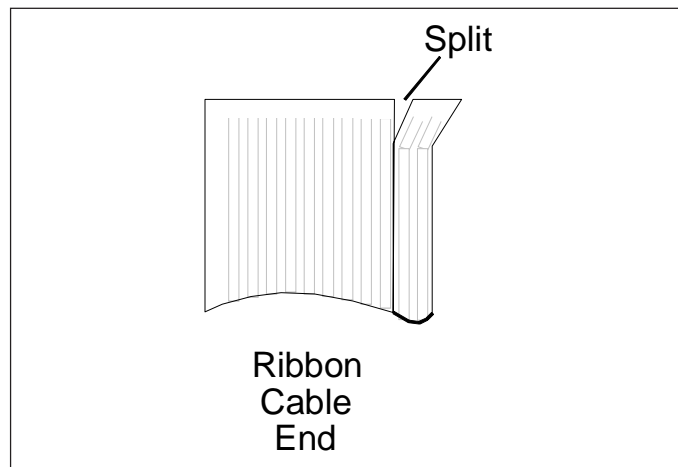

Connector -Side Keypad

Split in ribbon cable to the right as facing the front of the unit.

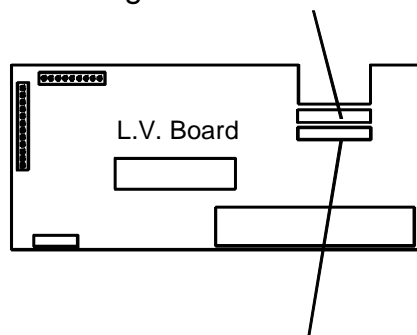

Connector - Top Keypad

Split in ribbon cable to the right as facing the front of the unit.

Side Keypad

1. Remove outer case.
2. Remove ribbon cable from low voltage circuit board.
3. Remove low voltage circuit board.
4. Loosen outer case trim.
5. Remove mounting screw(s).
6. Tilt side touch panel away from oven, release bottom mounting tabs (some models), and remove panel.

Low Voltage Circuit Board

1. Remove outer case.
2. Disconnect ribbon cables.
3. Disconnect connector from back of circuit board.
4. Squeeze clips together to depress the four standoffs and lift board out.

Disassembly

WARNING

To avoid the risk of electrical shock, personal injury, or death, disconnect power to oven and discharge capacitors before following any disassembly procedure.

Top Antennas

1. Remove outer case.
2. Remove grease shield.
3. While holding antenna, remove wire securing antenna to gear at top of unit.
4. Remove antenna.
5. Remove gear.

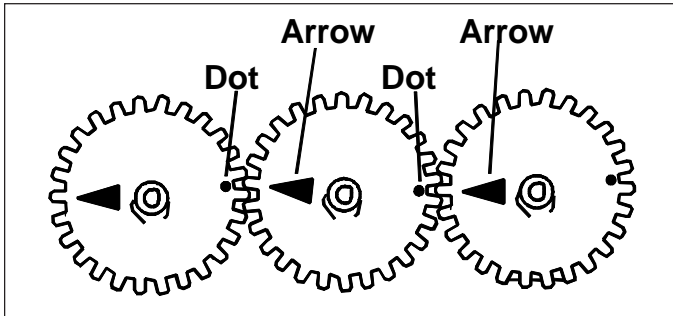

NOTE: Gears are aligned by aligning the arrows to the dots.

Antenna Matching

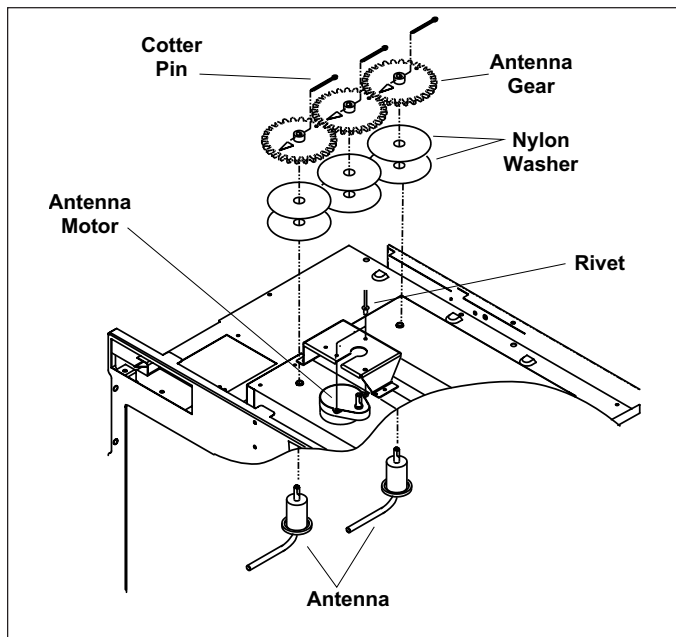
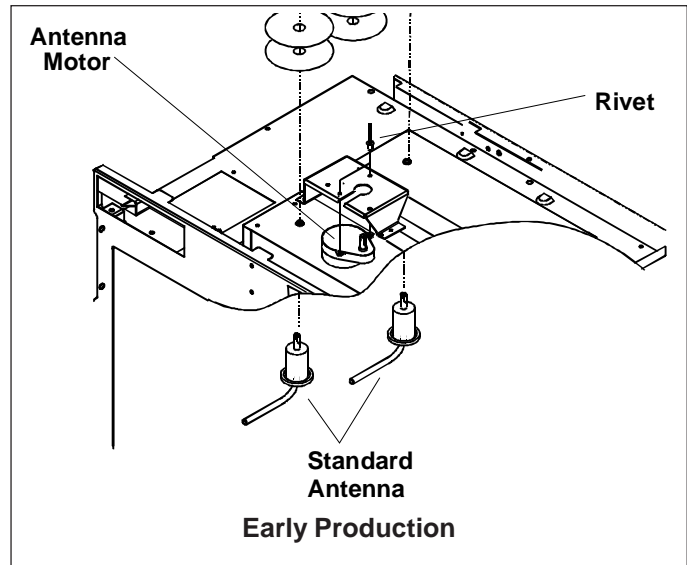

NOTE: Nylon washers must be installed below gears.

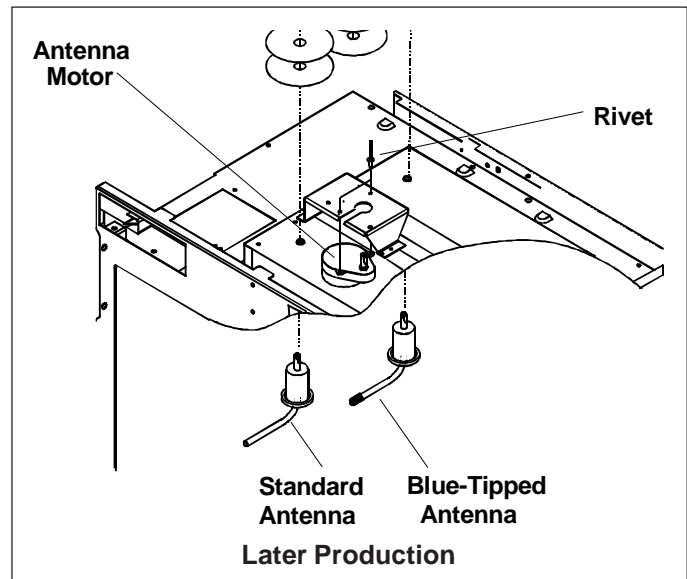

Top Antenna Motor

1. Remove outer case.
2. Remove three antenna gears.
3. Disconnect motor wiring.
4. Remove three stirrer motor bracket mounting rivets.
The motor and bracket are replaced as one part.

NOTE: Gears are aligned by aligning the arrows to the dots on gears.

WARNING

When servicing the top antennas, give careful attention to the color of the antenna tip. Part # 10787601 is standard non-colored. Part # 10787602 is blue-tipped. These **antennas are not interchangeable**. Refer to Parts Manual for correct application.

Disassembly



WARNING

To avoid the risk of electrical shock, personal injury, or death, disconnect power to oven and discharge capacitors before following any disassembly procedure.

Interlock Switch Assembly

1. Remove outer case.
2. Disconnect wiring.
3. Remove mounting screws securing mounting bracket to oven cavity and remove switch assembly from oven.
4. Re-connect wires to switch and check operation of monitor circuit before operating the oven.

NOTE: When the line fuse is open on models RC27 and KFC1, the **interlock switches and the power relay** must be replaced.

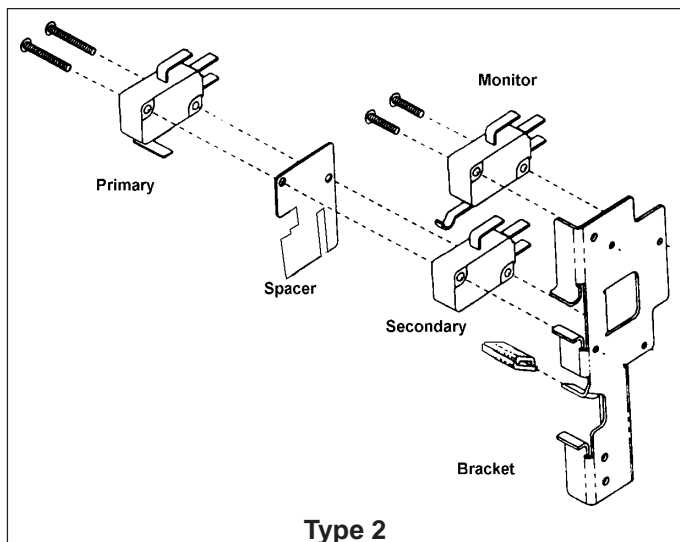
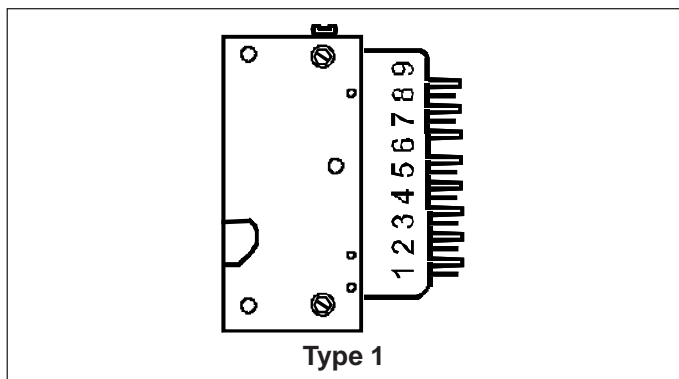

Adjustment

1. To adjust interlock switch assembly, close door.
2. Loosen bottom screw on the interlock switch assembly, allowing the switch assembly to move in or out.
3. With door closed, push forward on interlock assembly to engage door latch. Then pull back on interlock assembly until door is "snug" against front oven cavity and tighten bottom screw.
4. The door will remain latched when proper adjustment is made.

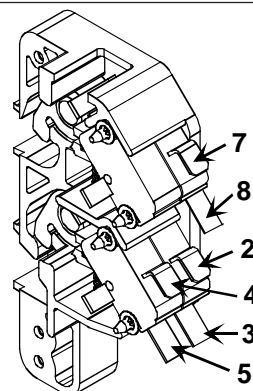

Type 3

Top Rear Magnetron

1. Removing outer case.
2. Remove top right air baffle by removing mounting screw.
3. Remove wires from thermal protectors and magnetron.
4. Remove center air baffle by removing two mounting screws located in top of the oven, do not attempt to remove air baffle at this time.
5. Remove four magnetron mounting nuts.
6. Remove magnetron and center air baffle.
7. When replacing the magnetron, verify the wire mesh gasket is reinstalled.

NOTE: When reinstalling magnetron, slide left air baffle on magnetron before placing magnetron in place.

Top Front Magnetron

1. Remove outer case.
2. Disconnect wire to thermal protectors and magnetron.
3. Remove low voltage circuit board.
4. Remove two left air baffle mounting screws (do not attempt to remove air baffle at this time).
5. Remove four magnetron mounting screws.
6. Remove left air baffle and magnetron.
7. When replacing the magnetron, verify the wire mesh gasket is reinstalled.

NOTE: Be sure to slide left air baffle on magnetron before reinstalling the magnetron.

Disassembly



To avoid the risk of electrical shock, personal injury, or death, disconnect power to oven and discharge capacitors before following any disassembly procedure.

Bottom Magnetron

1. Remove outer case.
2. Disconnect wires from the magnetron thermal protectors and the magnetron.
3. Remove bottom magnetron air duct.
4. Remove middle baffle mounting screw and slide air baffle out of the way.
5. Place unit on its left side.
6. Remove bottom access panel.
7. Remove four magnetron mounting nuts.
8. Remove magnetron.

Installation

1. Install magnetron - do not tighten nuts.
2. Install magnetron air baffle.
3. Tighten magnetron mounting nuts.
4. Reinstall middle air baffle.
5. Install bottom access cover.
6. Connect wiring to magnetron and magnetron thermal protectors.
7. When replacing the magnetron, verify the wire mesh gasket is reinstalled.
8. Install outer case.

Magnetron and Control Thermal Protectors (TCO)

1. Remove outer case.
2. Remove wiring from selected thermal protector.
3. Remove 1/8" allen screw/phillips screw used to mount thermal protectors.

Bottom Access Panel

1. Place oven on side or back.
2. Remove single bottom screw.

Bottom Stirrer Motor

1. Remove bottom access panel.
2. Remove antenna gear.
3. Disconnect brown motor wires from white and orange chassis wires.
4. Remove two mounting rivets and remove motor.

NOTE: Do not remove bottom antenna gear when removing motor.

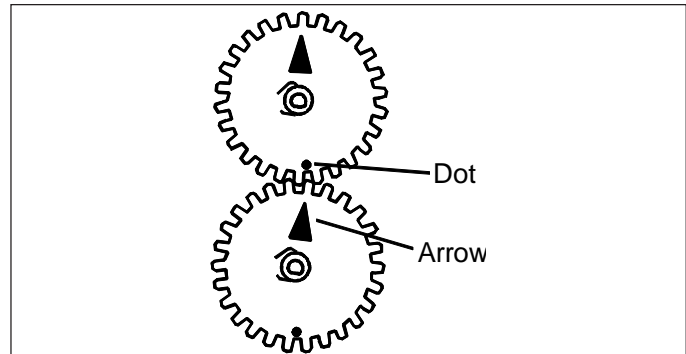

NOTE: Gears are aligned by aligning the arrows to the dots on gears.

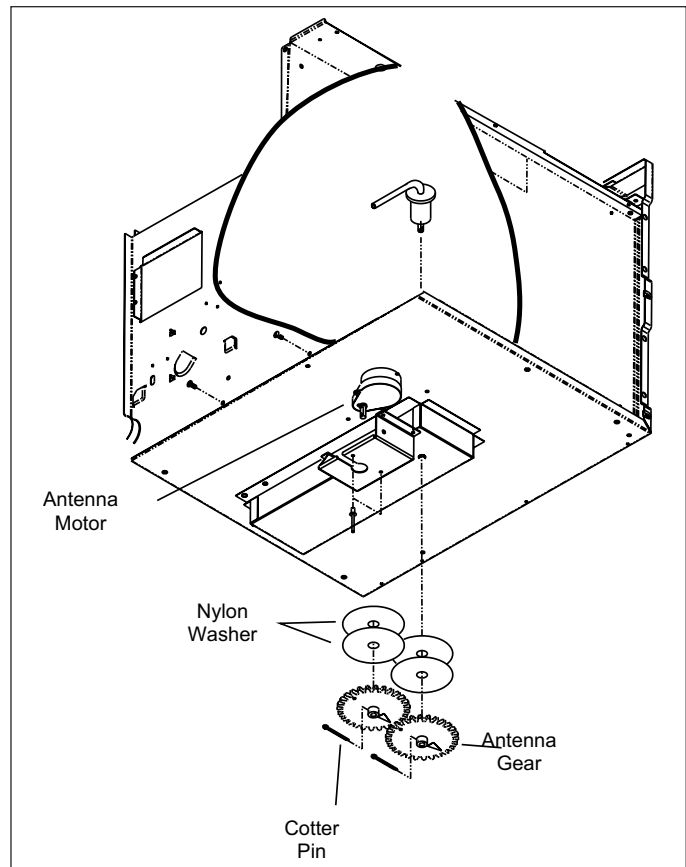

NOTE: Nylon washers must be installed between antenna gears and cavity.

Disassembly



WARNING

To avoid the risk of electrical shock, personal injury, or death, disconnect power to oven and discharge capacitors before following any disassembly procedure.

Bottom Antenna

1. Remove shelf.
2. Set oven on side.
3. Remove bottom access panel.
4. Removal antenna gear.

NOTE: Gears are aligned by aligning the arrows to the dots on gears.

5. Remove antenna from top.
6. Replace and reseal shelf.

Back Panel

1. Remove outer case.
2. Remove six panel mounting screws.

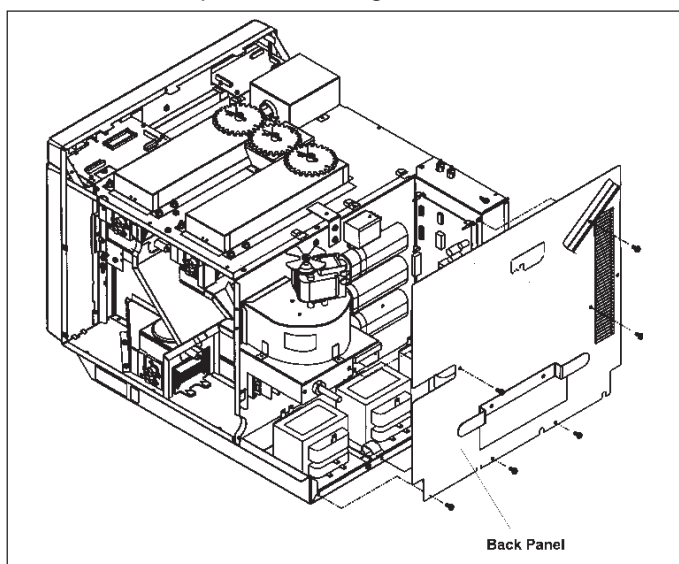

Following are Accessible by Removing Back Panel

- Oven relay
- Blower (see additional instructions)
- Diodes
- Capacitors
 - Top for top front magnetron
 - Middle for top rear magnetron
 - Bottom for bottom magnetron
- H.V. transformers (two mounting screws on back flange and slide transformer out).
 - Right for top front magnetron
 - Middle for top rear magnetron
 - Left for bottom magnetron
- Triacs
 - Back for top front magnetron
 - Middle for top rear magnetron
 - Front for bottom magnetron
- Autotransformer
- H.V. circuit board
- Fuses

Blower Wheel and Motor

1. Remove outer case.
2. Remove back panel.
3. Remove auto transformer.
4. Remove wiring to blower motor.
5. Remove the one blower assembly mounting screw located under the support brace and remove assembly.
6. Remove three mounting screws located under blower housing assembly.
7. Remove assembly from oven.
8. Loosen the 1/8 inch allen set screw securing blower wheel to shaft.
9. Remove three blower mounting housing screws.
10. Remove blower wheel.
11. Remove four motor mounting bolts.
12. When reinstalling blower wheel, push blower wheel on shaft and rotate to insure clearance between blower wheel, blower housing, and mounting bolts.

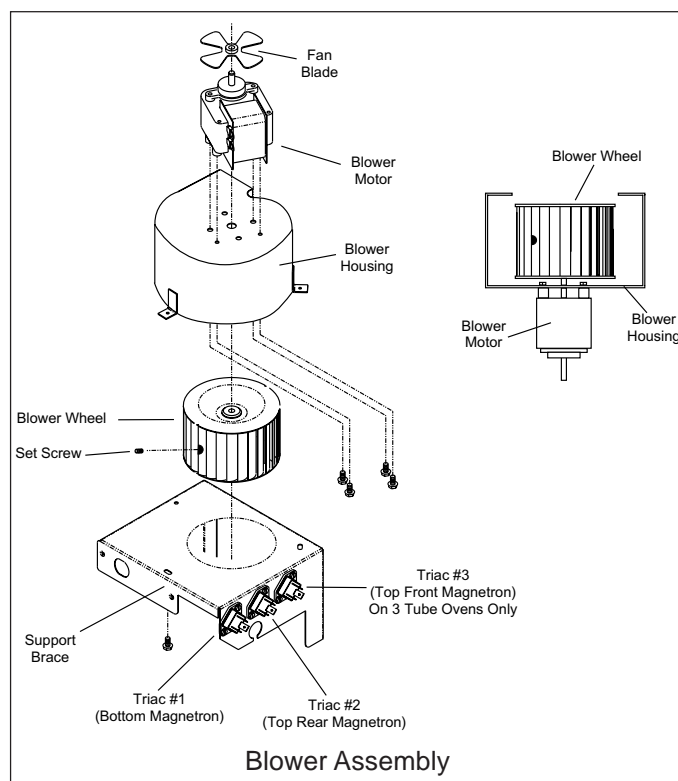

Disassembly

WARNING

To avoid the risk of electrical shock, personal injury, or death, disconnect power to oven and discharge capacitors before following any disassembly procedure.

Fan Blade

1. Remove top mounting clip from end of shaft.
2. Pull blade off shaft.
3. When reinstalling blade, push blade on shaft and rotate to insure clearance between fan blade and motor mounting bolt.

H.V. Board

1. Unplug connectors.
2. Disconnect wires from terminals E1, E2, and E3.
3. Disconnect sense loop wire from cavity thermal protector.

NOTE: Be sure to route wire through sensing loop when replacing high voltage board.

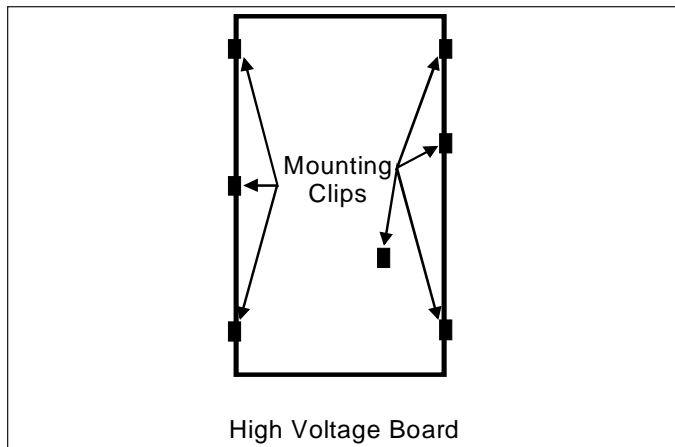
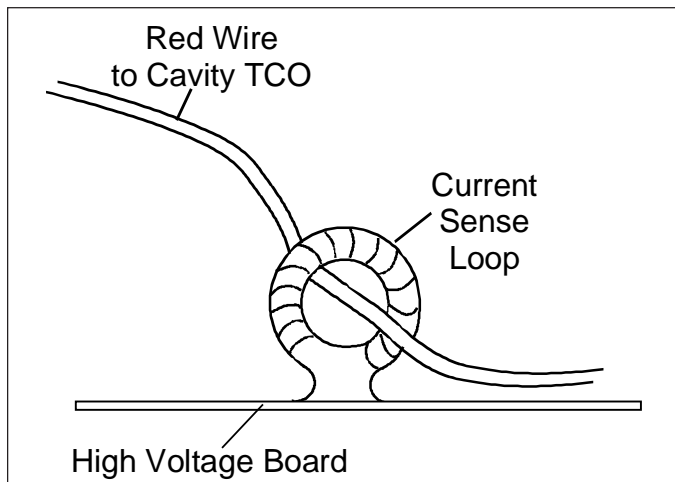

4. Disconnect seven mounting clips, by pushing clips away from the board.

Cavity Thermal Protector (TCO)

1. Removing inner side panel by removing four mounting screws.
2. Remove thermal protector mounting screw (protective covering inside of cavity must be held).
3. Disconnect wiring.

Power Cord

1. Remove outer case assembly.
2. Disconnect wiring.
3. Remove strain relief by compressing with pliers.
4. Remove power cord.

Component Location

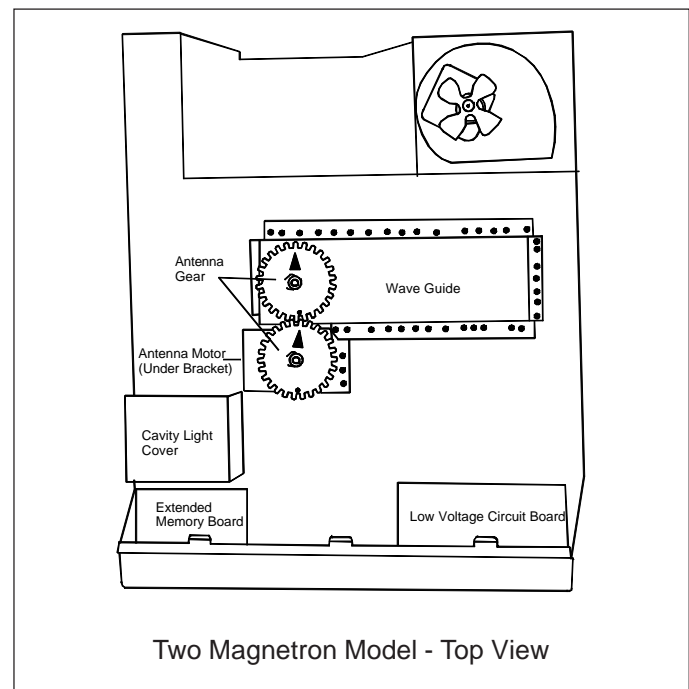
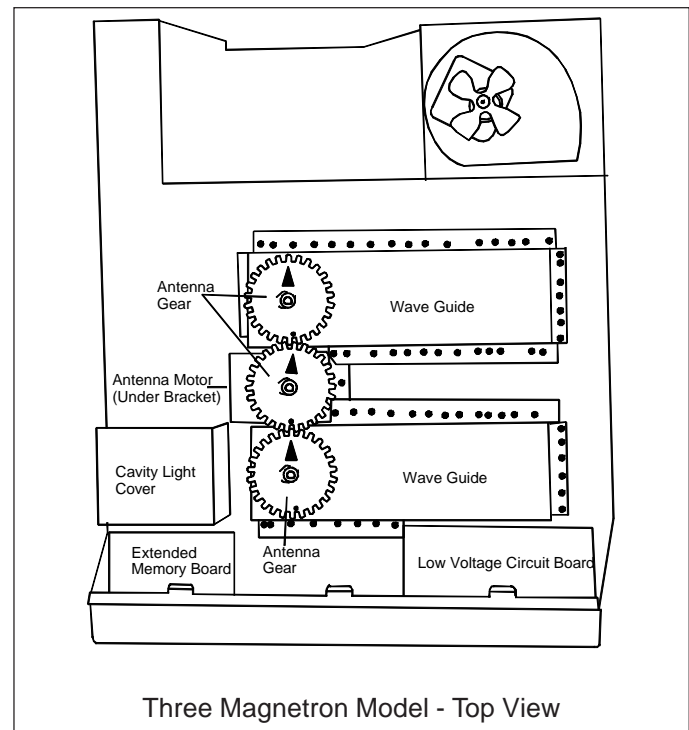

Disassembly

 **WARNING**

To avoid the risk of electrical shock, personal injury, or death, disconnect power to oven and discharge capacitors before following any disassembly procedure.

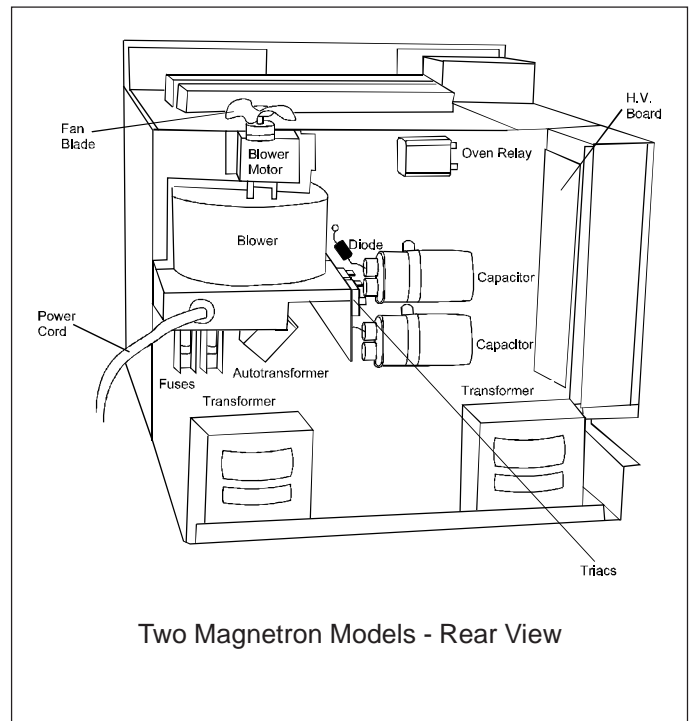
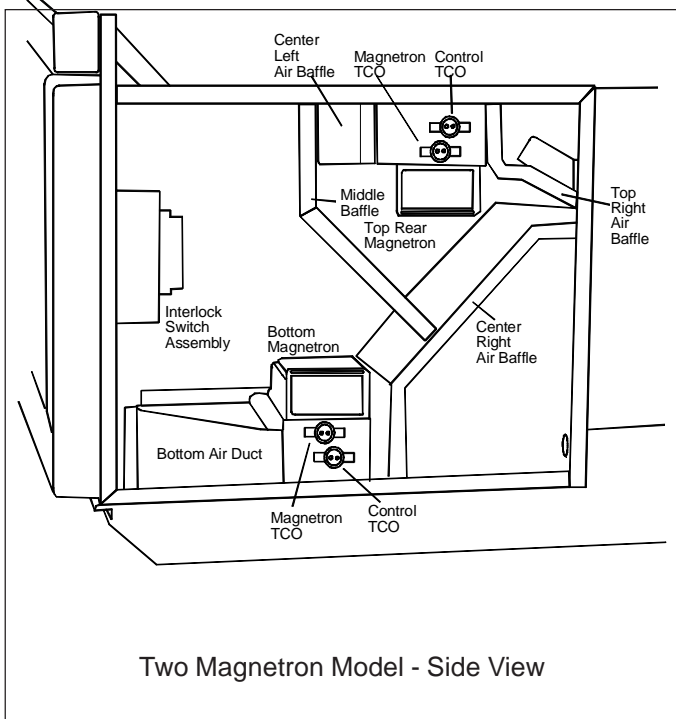
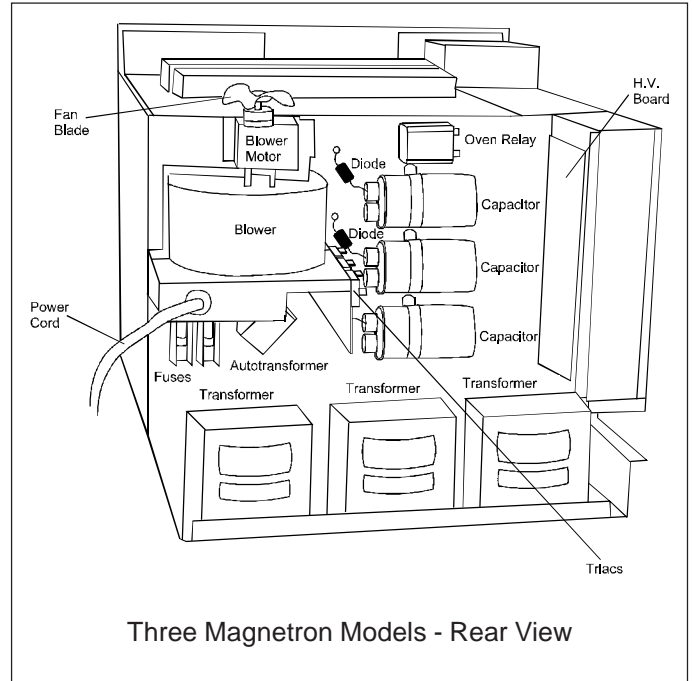
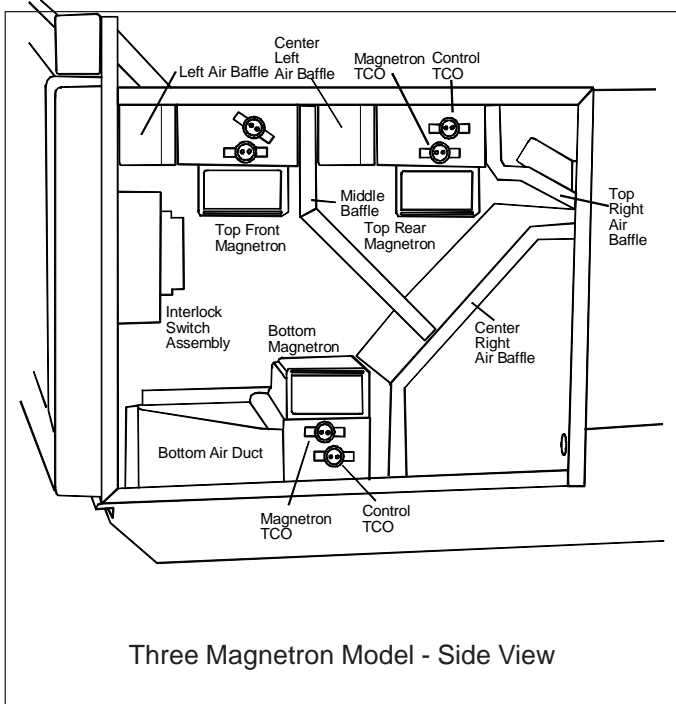

Disassembly

 **WARNING**

To avoid the risk of electrical shock, personal injury, or death, disconnect power to oven and discharge capacitors before following any disassembly procedure.

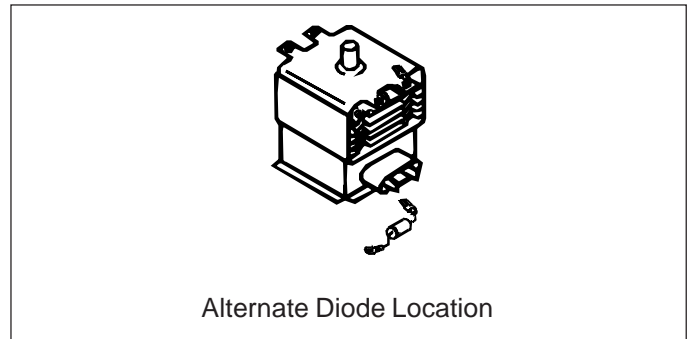
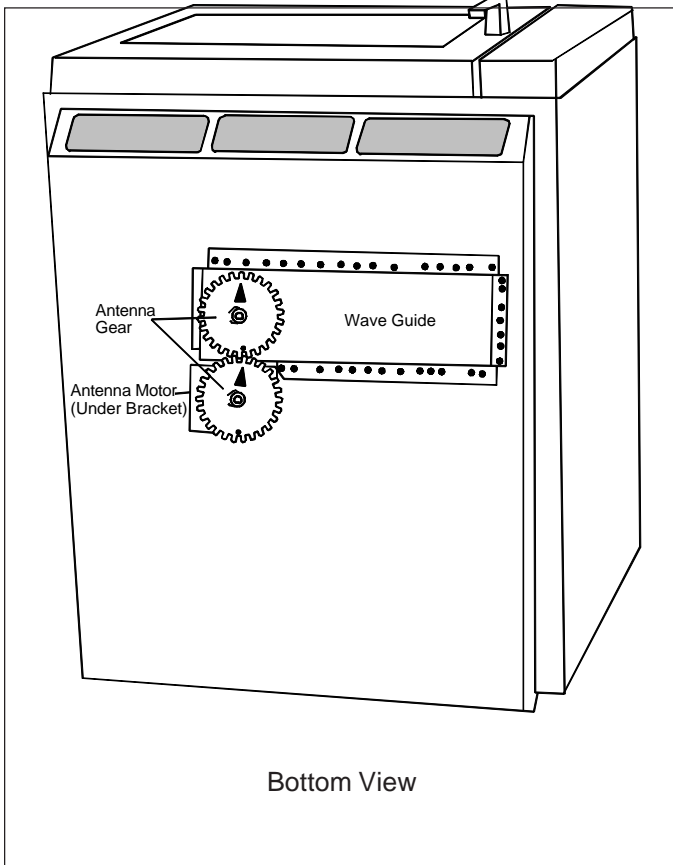

Wiring Diagrams and Schematics



WARNING

To avoid risk of electrical shock, personal injury, or death, disconnect power to oven and discharge capacitor before servicing, unless testing requires power.

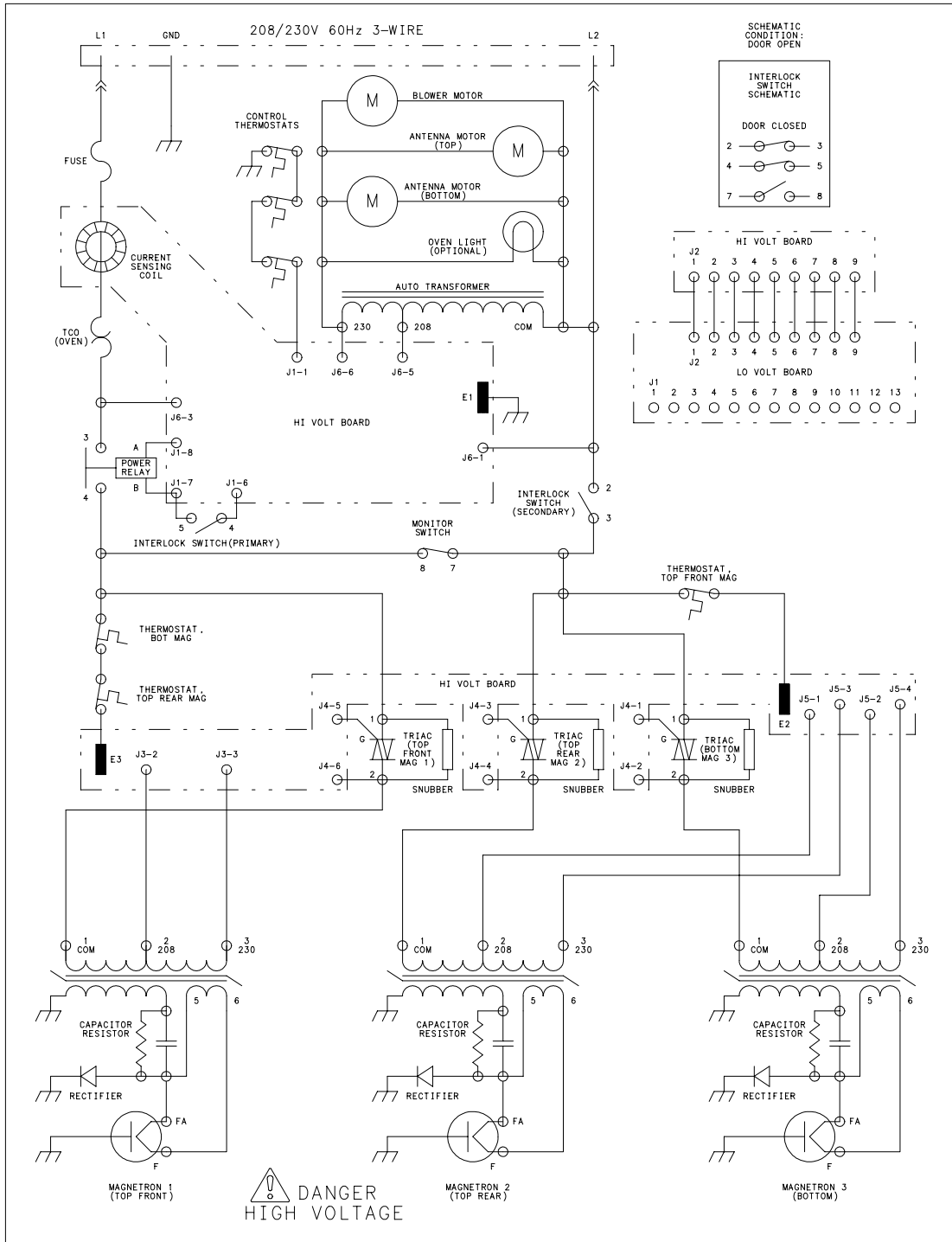

⚠ DANGER HIGH VOLTAGE

RC22
RC22MP
RC22MPS

P1107909M
P1107902M
P1107906M

Wiring Diagrams and Schematics



WARNING

To avoid risk of electrical shock, personal injury, or death, disconnect power to oven and discharge capacitor before servicing, unless testing requires power.

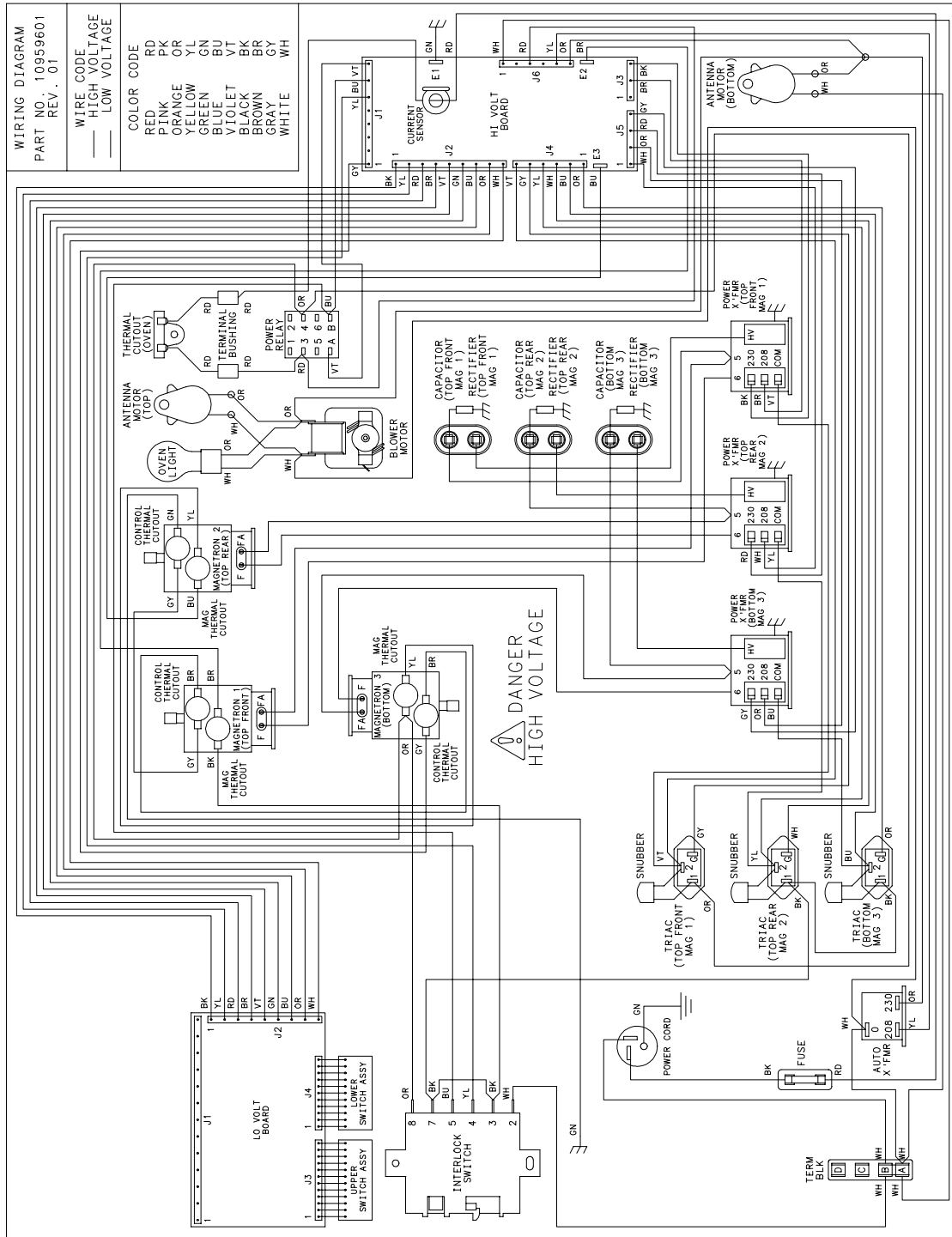

RC22
RC22MP
RC22MPS

P1107909M
P1107902M
P1107906M

Wiring Diagrams and Schematics



WARNING

To avoid risk of electrical shock, personal injury, or death, disconnect power to oven and discharge capacitor before servicing, unless testing requires power.

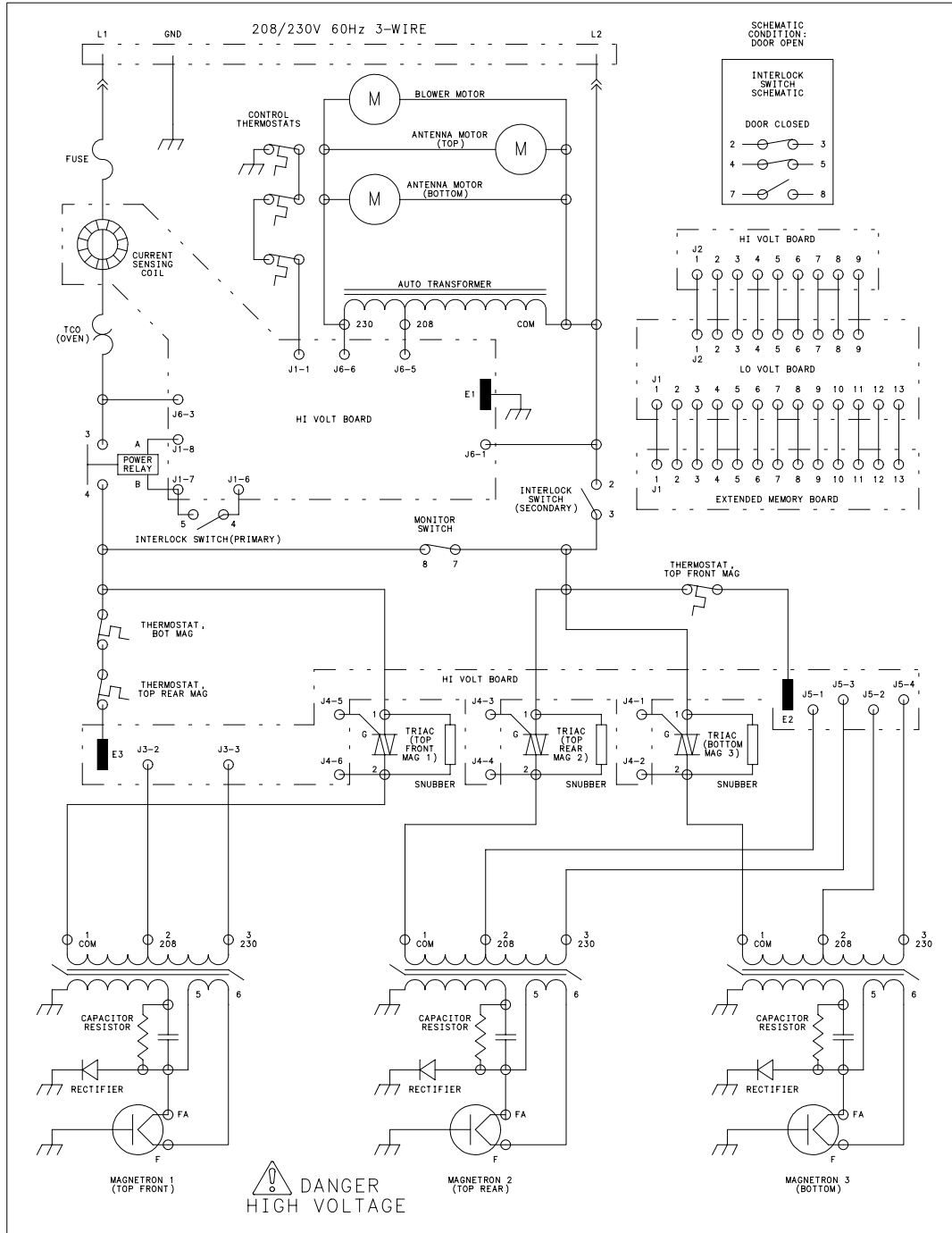

⚠ DANGER HIGH VOLTAGE

DQ22HS
MC22MP

P1107908M
P1107904M

Wiring Diagrams and Schematics



WARNING

To avoid risk of electrical shock, personal injury, or death, disconnect power to oven and discharge capacitor before servicing, unless testing requires power.

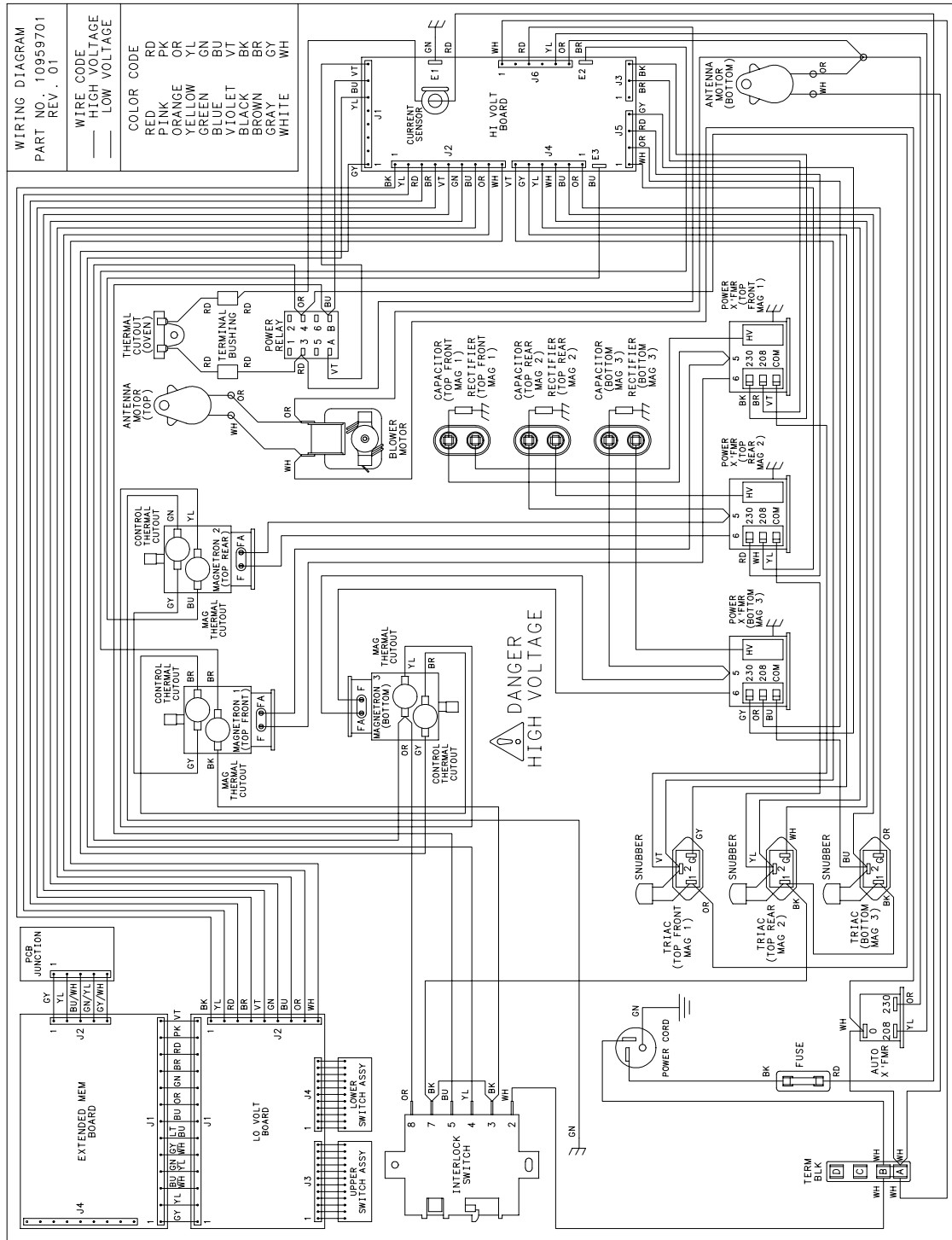

DQ22HS
MC22MP

P1107908M
P1107904M

Wiring Diagrams and Schematics



WARNING

To avoid risk of electrical shock, personal injury, or death, disconnect power to oven and discharge capacitor before servicing, unless testing requires power.

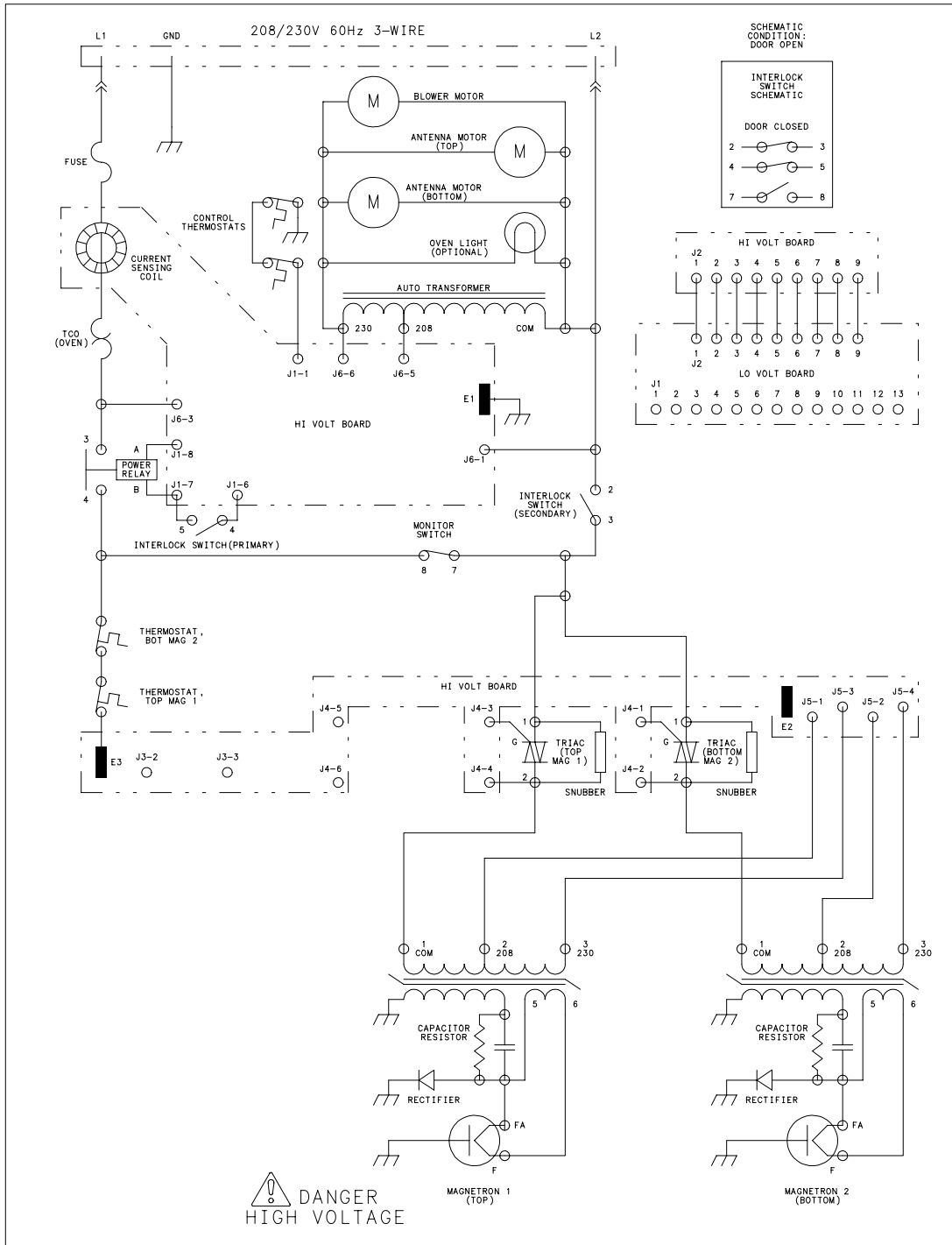

RC16MP
RC17

P1191101M
P1191104M

Wiring Diagrams and Schematics



WARNING

To avoid risk of electrical shock, personal injury, or death, disconnect power to oven and discharge capacitor before servicing, unless testing requires power.

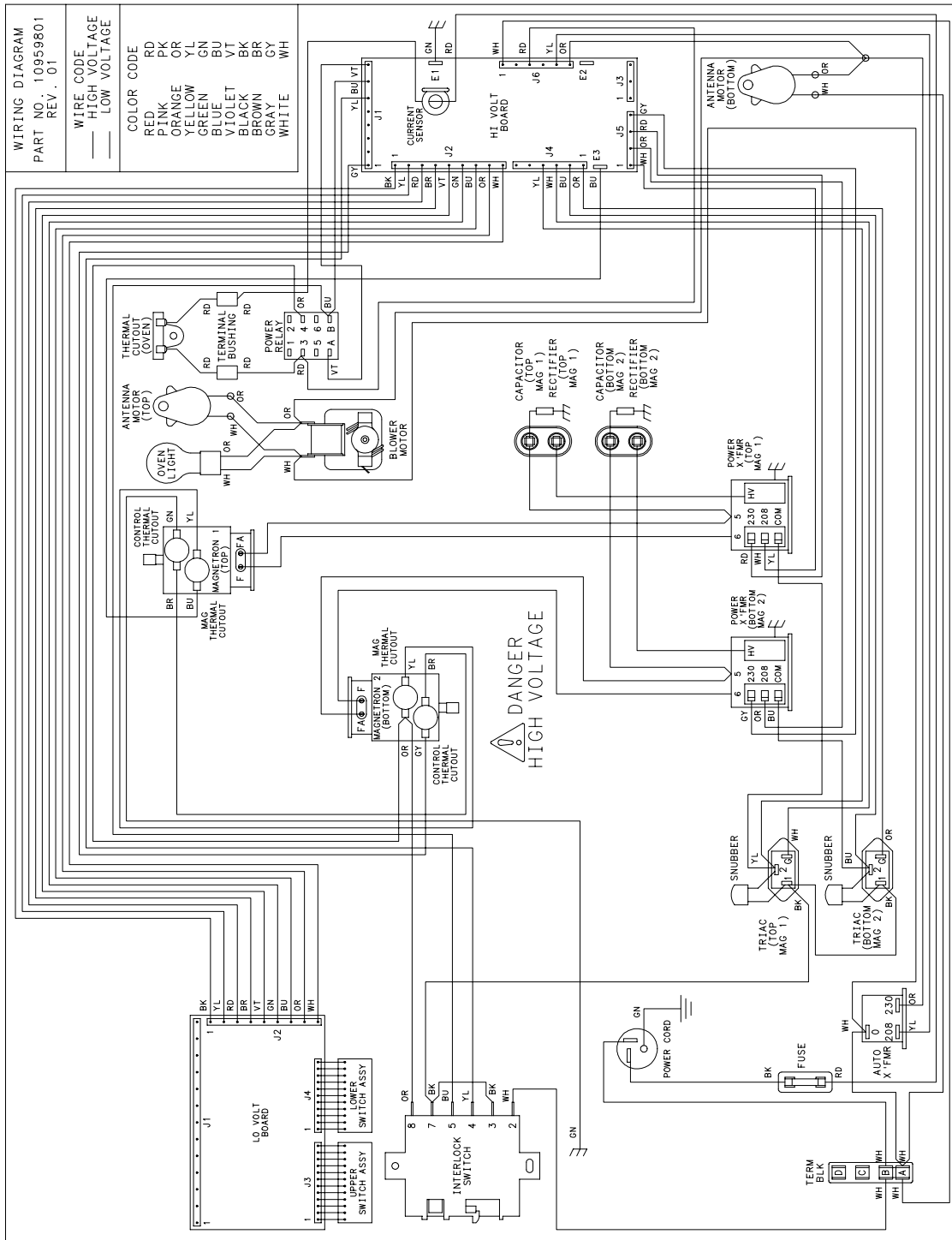

Wiring Diagrams and Schematics



WARNING

To avoid risk of electrical shock, personal injury, or death, disconnect power to oven and discharge capacitor before servicing, unless testing requires power.

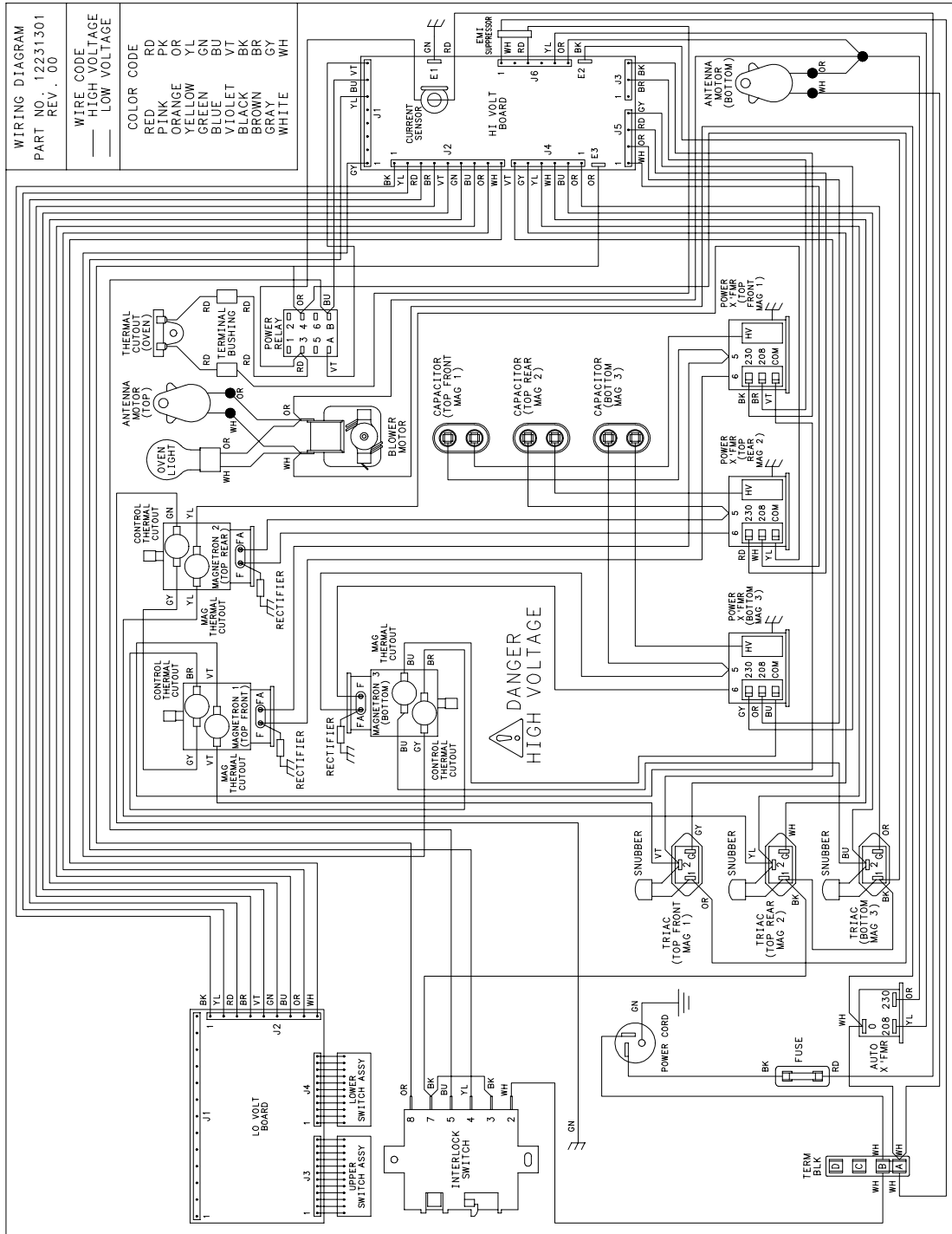

RC22
RC22S
RC22LW
RC22LW

P1198604M
P1198605M
P1198610M
P1198611M

Wiring Diagrams and Schematics



WARNING

To avoid risk of electrical shock, personal injury, or death, disconnect power to oven and discharge capacitor before servicing, unless testing requires power.

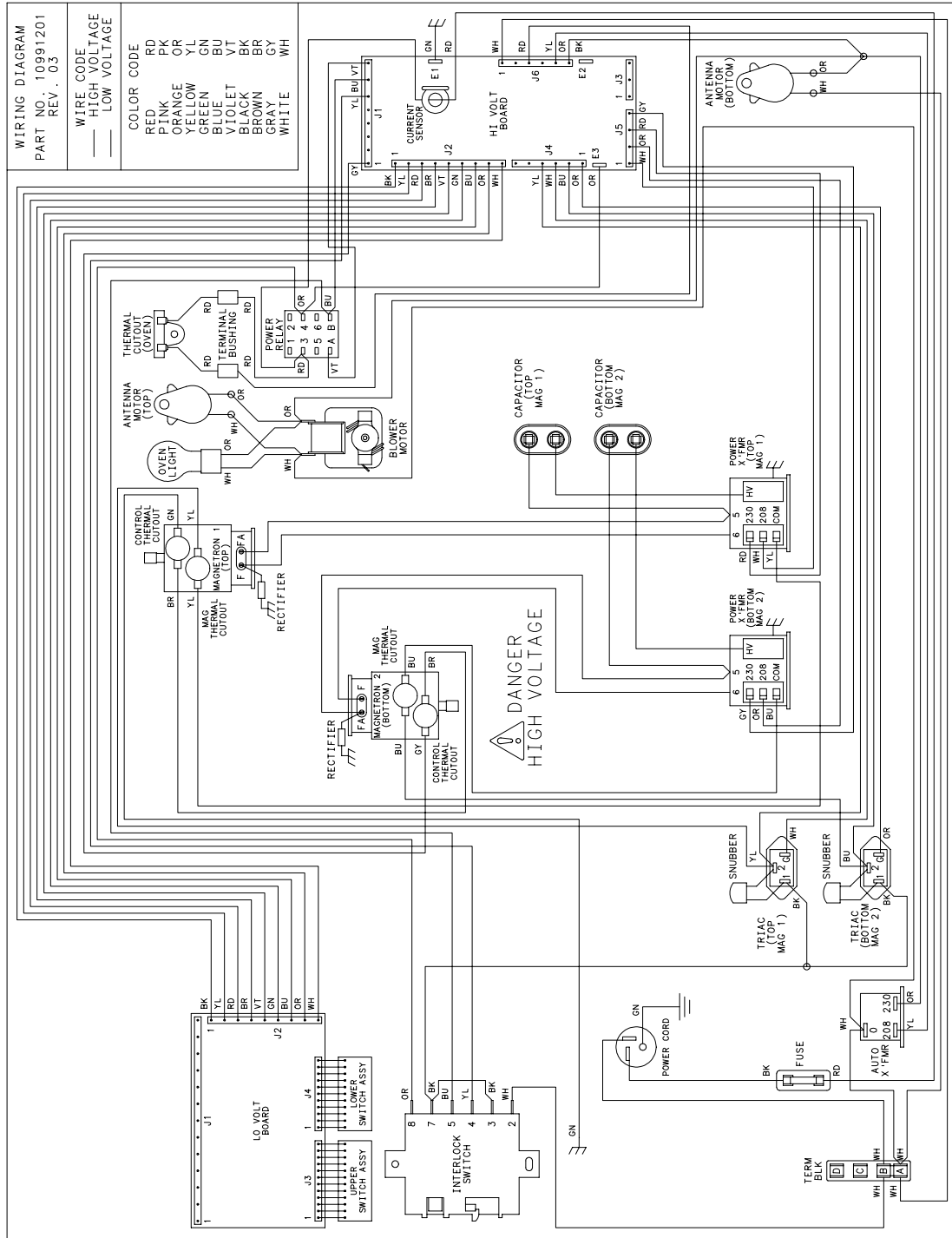

Wiring Diagrams and Schematics



WARNING

To avoid risk of electrical shock, personal injury, or death, disconnect power to oven and discharge capacitor before servicing, unless testing requires power.

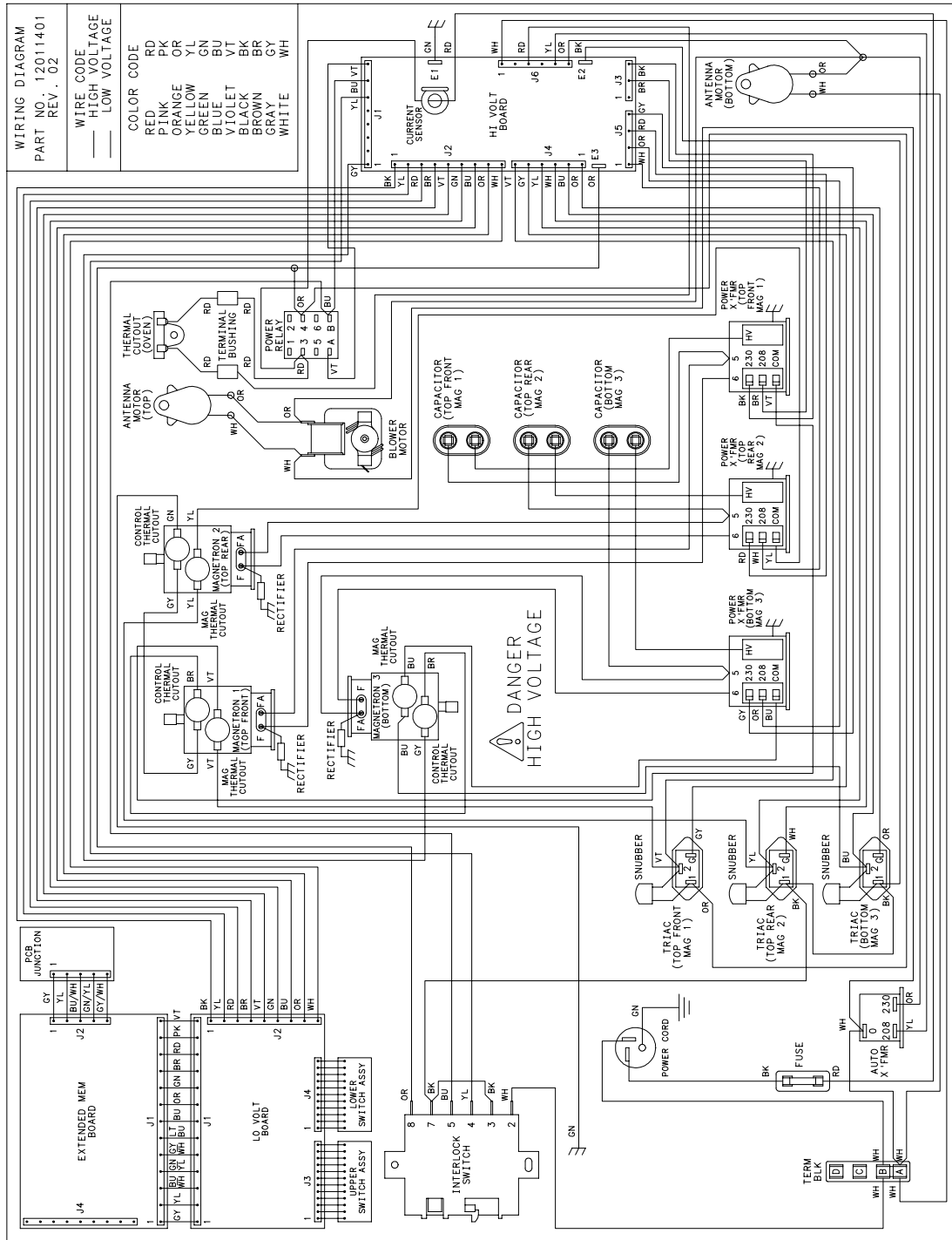

DQ22HS
MC22MP
MC22MPT

P1198607M
P1198701M
P1198702M

Wiring Diagrams and Schematics



WARNING

To avoid risk of electrical shock, personal injury, or death, disconnect power to oven and discharge capacitor before servicing, unless testing requires power.

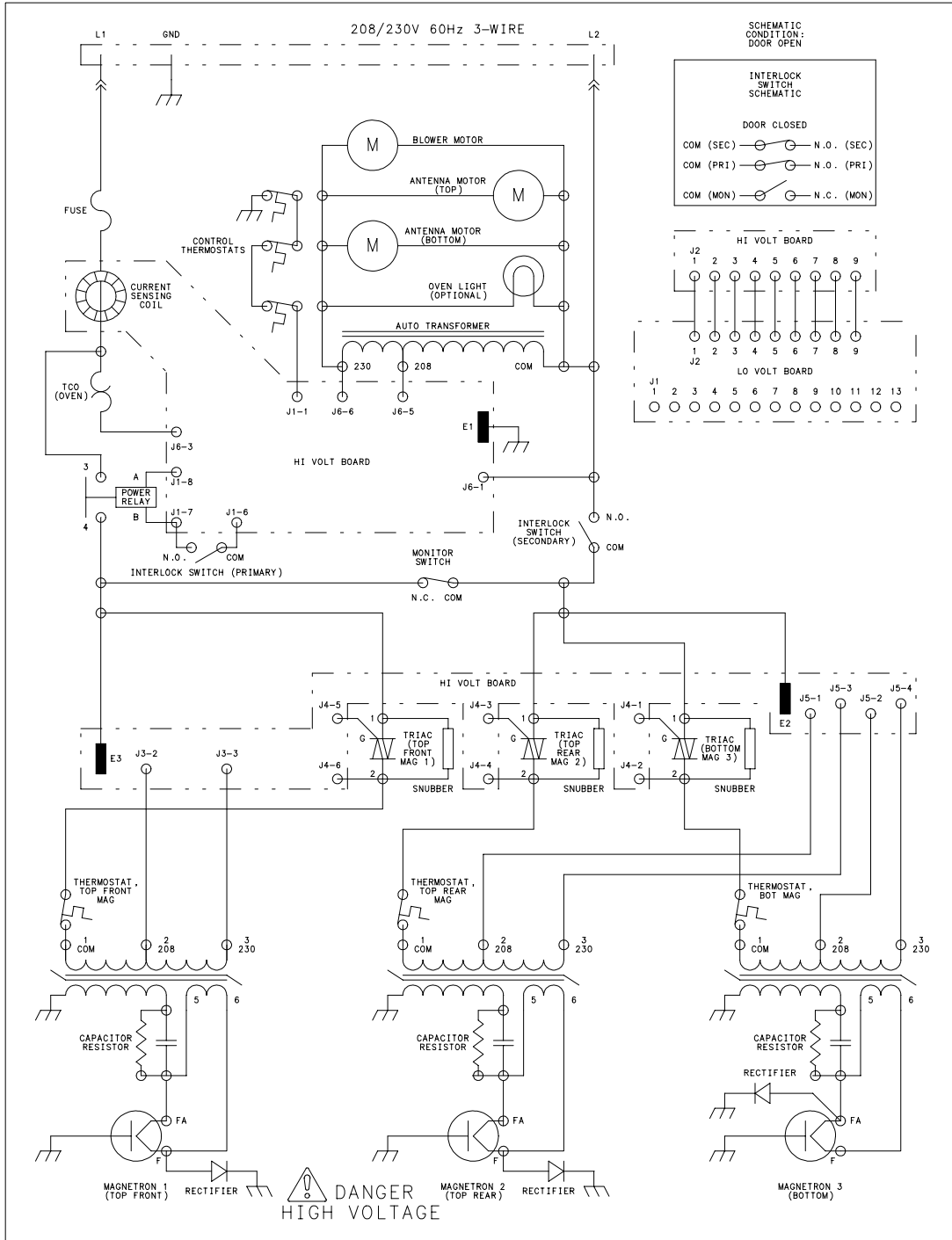

RC27

P1198608M

Wiring Diagrams and Schematics



WARNING

To avoid risk of electrical shock, personal injury, or death, disconnect power to oven and discharge capacitor before servicing, unless testing requires power.

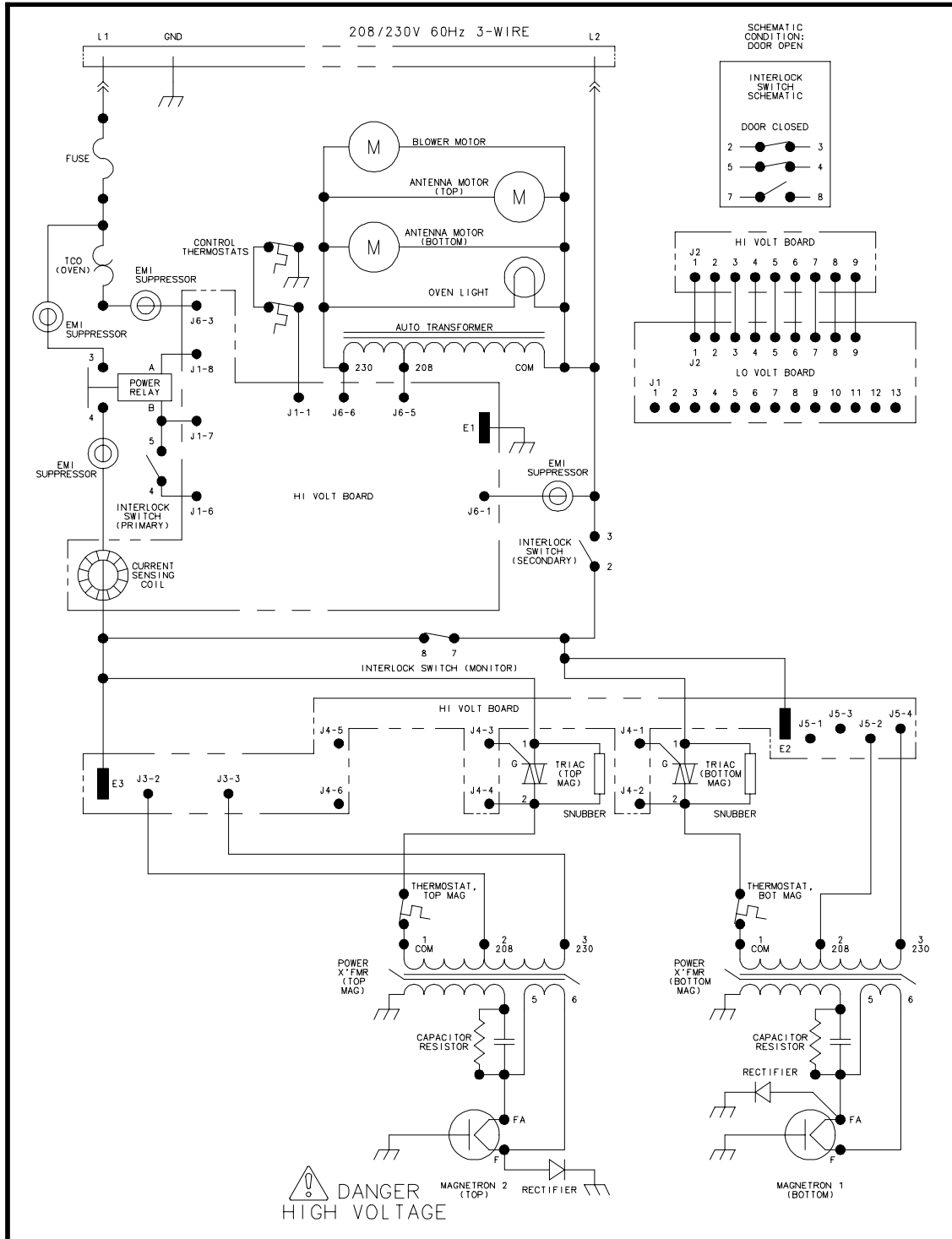

RC17 P1198612M RC17SD P1198623M

Wiring Diagrams and Schematics



WARNING

To avoid risk of electrical shock, personal injury, or death, disconnect power to oven and discharge capacitor before servicing, unless testing requires power.

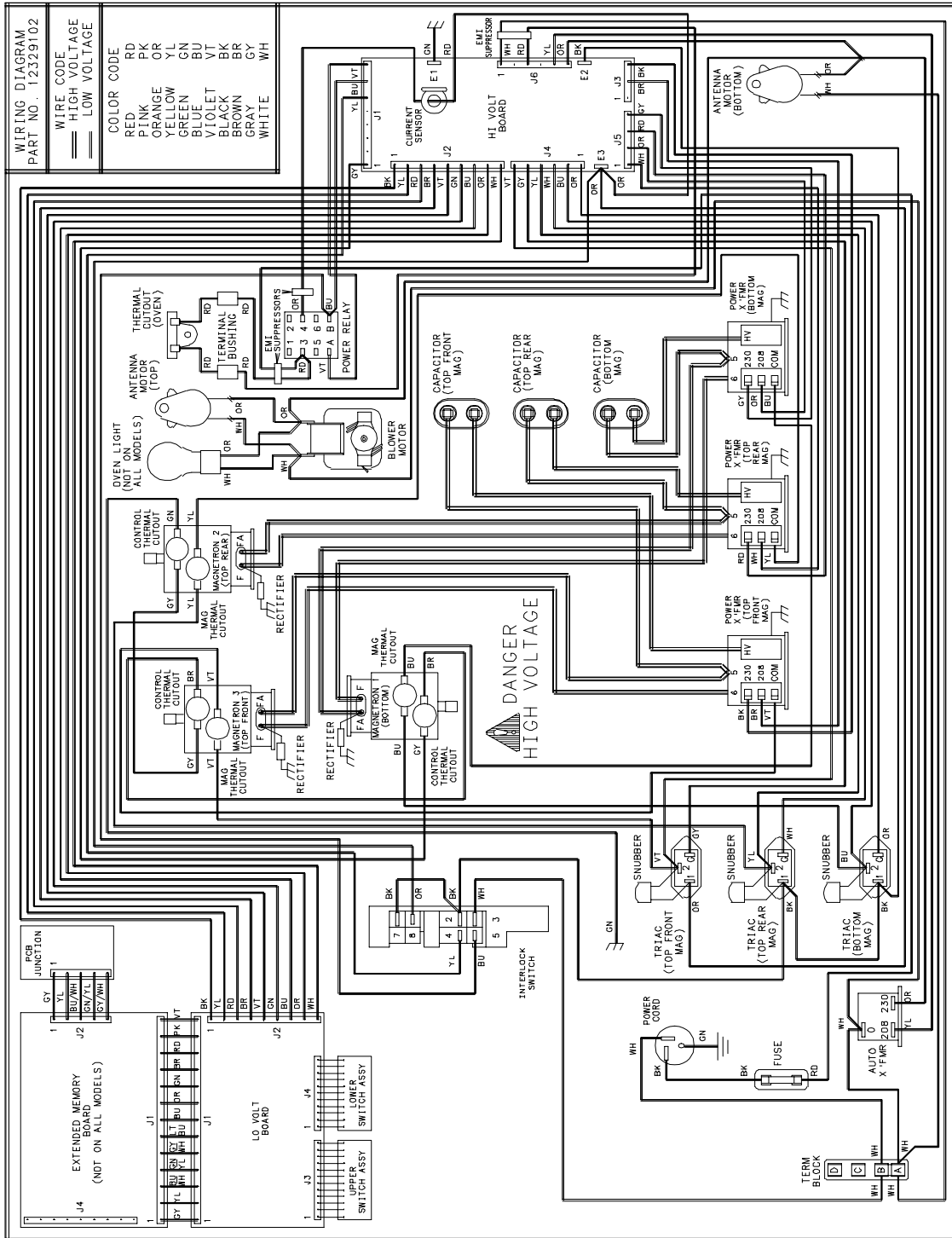

RC22
MC22MPT
KFC1

P1198614M
P1198704M
P1198622M

DQ22HS
MC22MPT2

P1198617M
P1198705M

MC22MP
RC27

P1198703M
P1198618M

Wiring Diagrams and Schematics



WARNING

To avoid risk of electrical shock, personal injury, or death, disconnect power to oven and discharge capacitor before servicing, unless testing requires power.

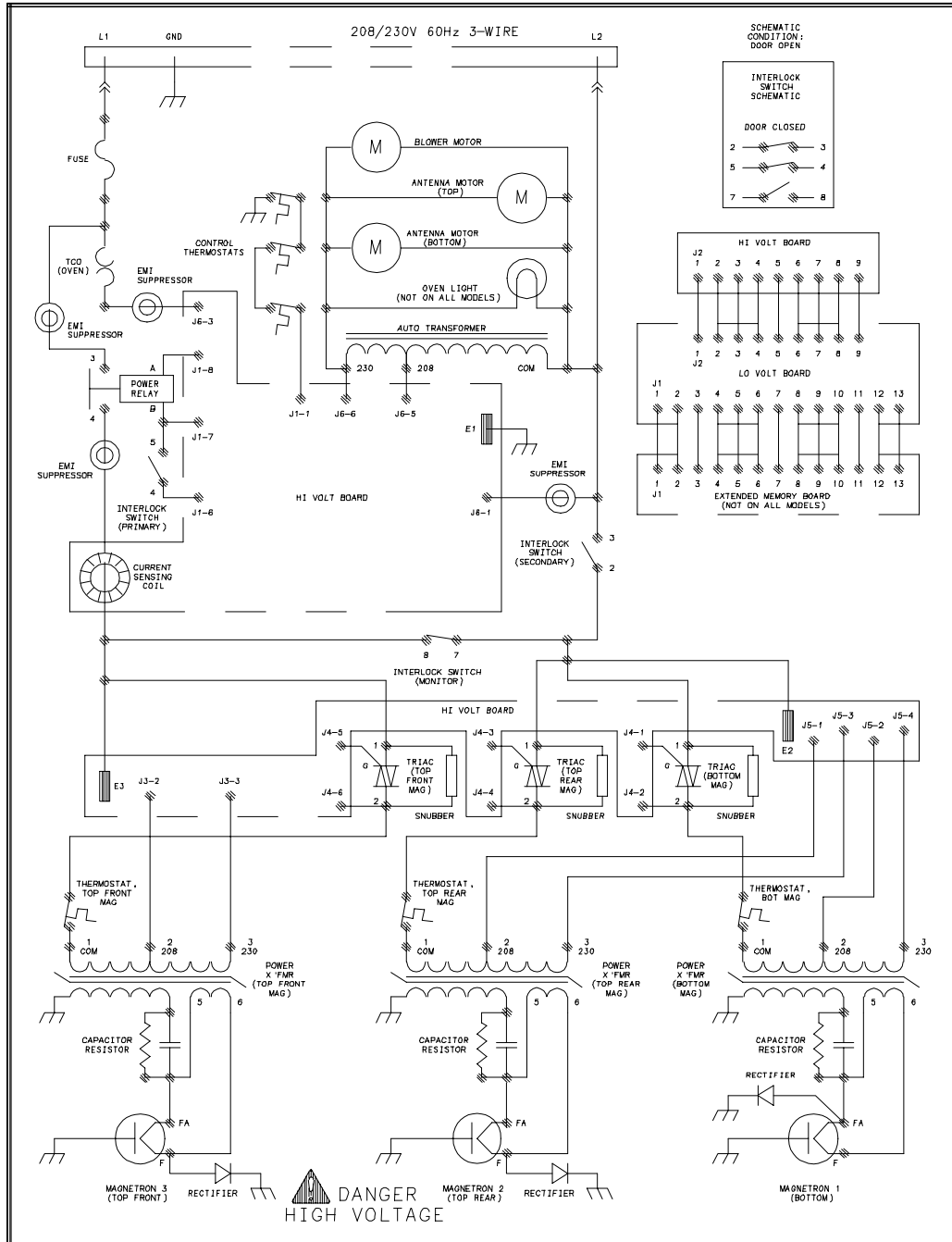

RC22
MC22MPT
KFC1

P1198614M
P1198704M
P1198622M

DQ22HS
MC22MPT2

P1198617M
P1198705M

MC22MP
RC27

P1198703M
P1198618M

Wiring Diagrams and Schematics



WARNING

To avoid risk of electrical shock, personal injury, or death, disconnect power to oven and discharge capacitor before servicing, unless testing requires power.

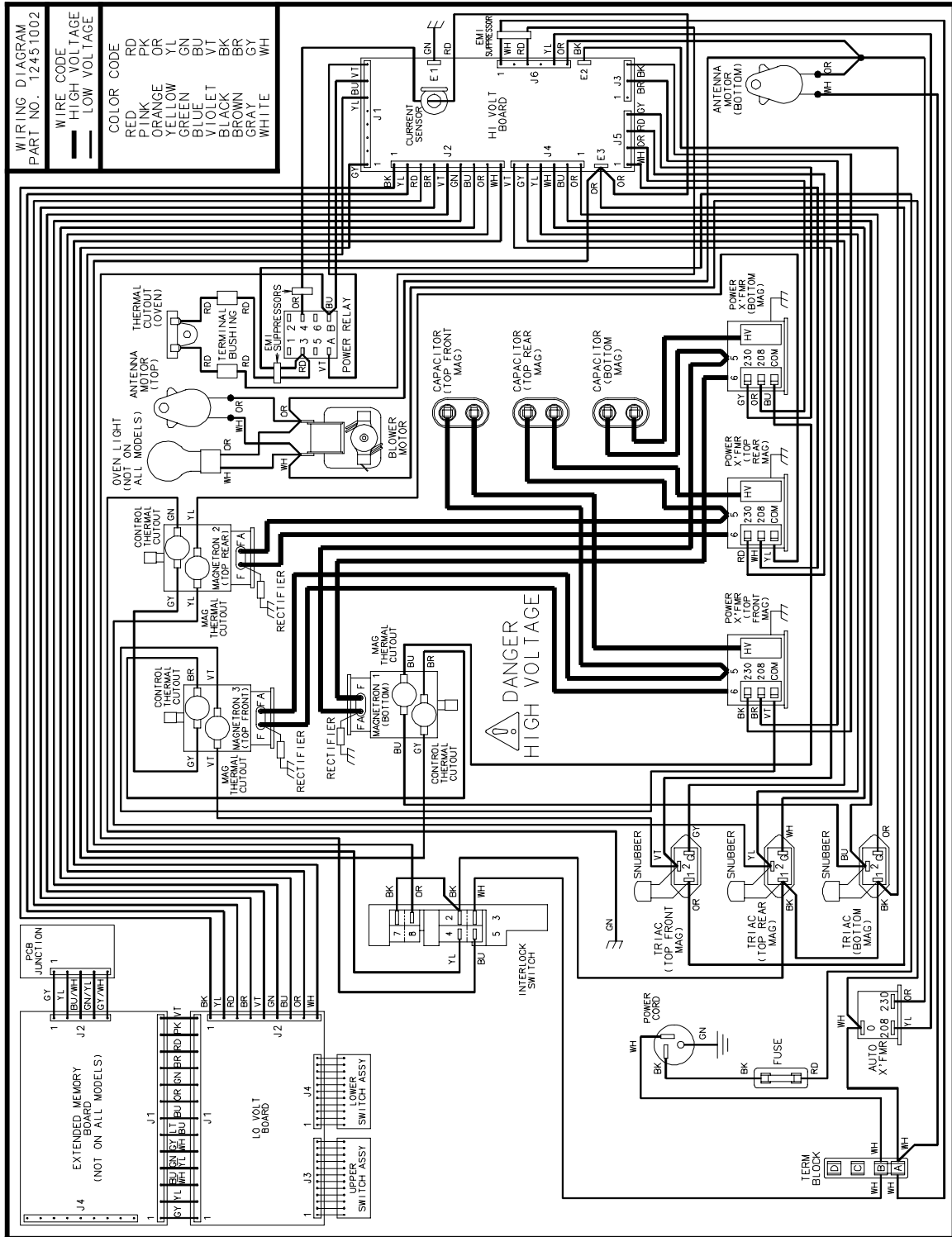

12451002

WDYRC P1198621M

Wiring Diagrams and Schematics



WARNING

To avoid risk of electrical shock, personal injury, or death, disconnect power to oven and discharge capacitor before servicing, unless testing requires power.

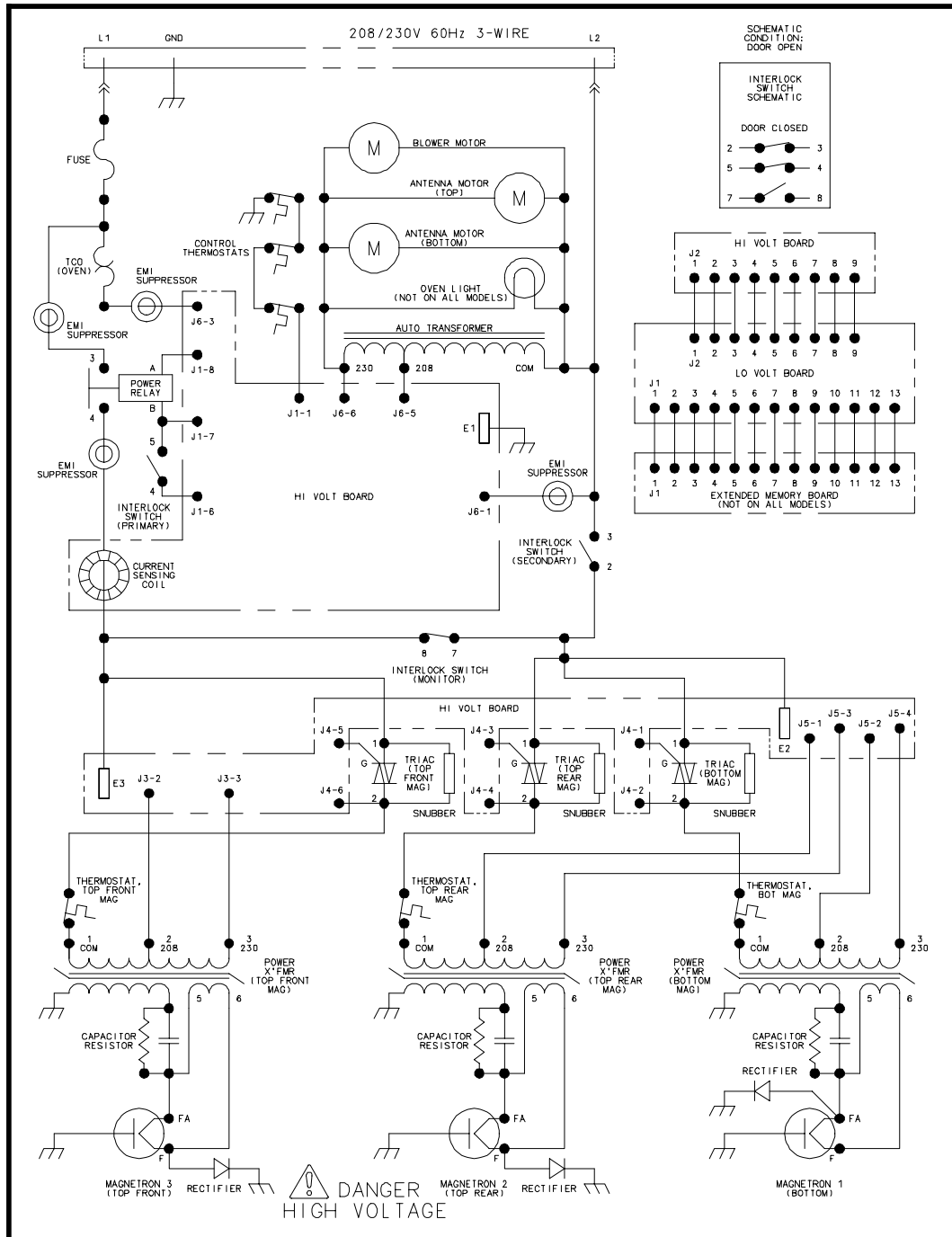

12451002



DANGER

HIGH VOLTAGE

WDYRC

P1198621M

Wiring Diagrams and Schematics



WARNING

To avoid risk of electrical shock, personal injury, or death, disconnect power to oven and discharge capacitor before servicing, unless testing requires power.

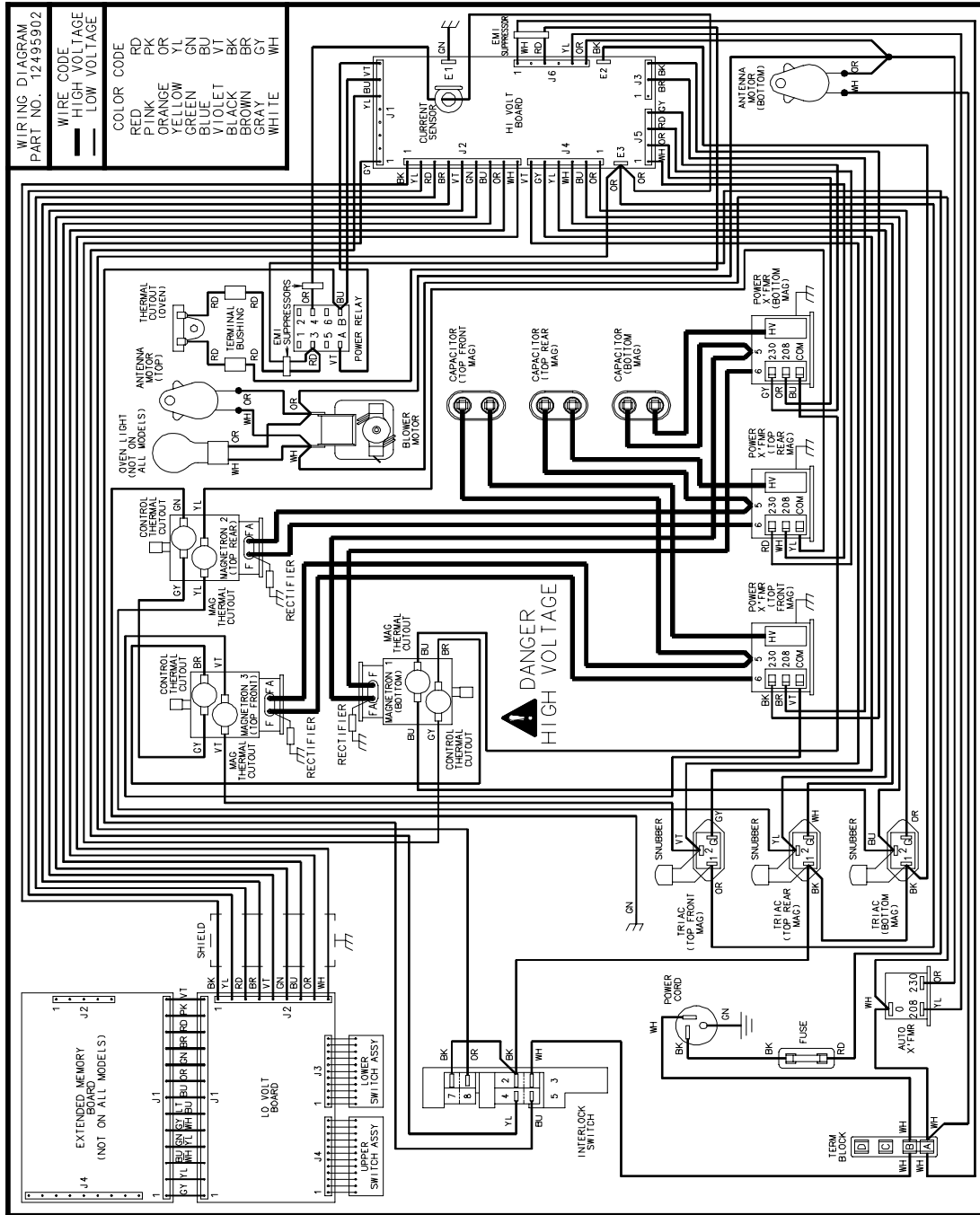

12495902



MC22MP

P1198706M

MC22MPT

P1198707M

MC22MPT2

P1198708M

Wiring Diagrams and Schematics



WARNING

To avoid risk of electrical shock, personal injury, or death, disconnect power to oven and discharge capacitor before servicing, unless testing requires power.

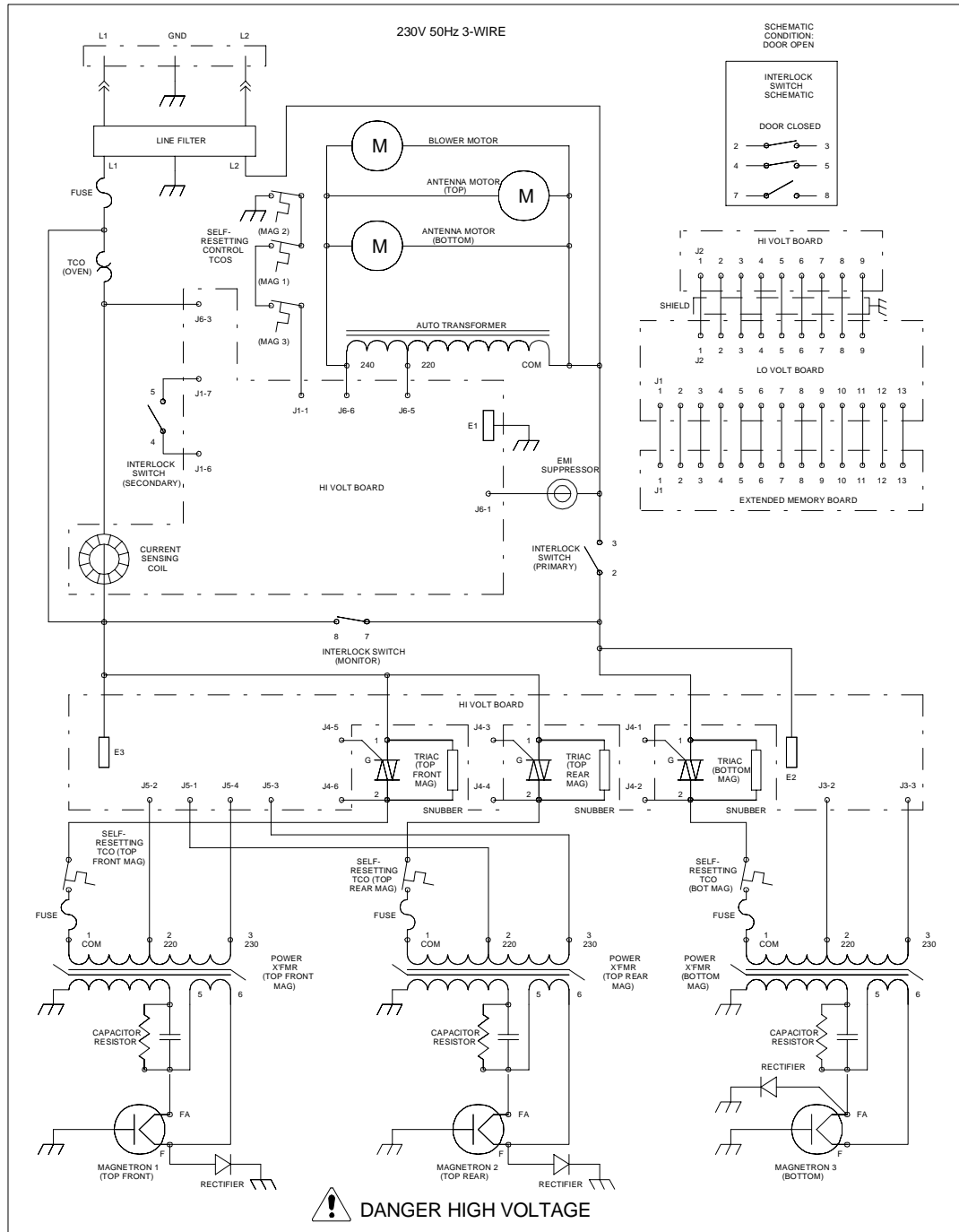

12495902



DANGER

HIGH VOLTAGE

MC22MP

P1198706M

MC22MPT

P1198707M

MC22MPT2

P1198708M