



**TUMBLE DRYER**  
**Vented WTA34.. / WTA35..**

---

<b>I.</b>	<b>SAFETY INFORMATION</b>	<b>Page</b>	<b>1</b>
<b>II.</b>	<b>OPERATION</b>	<b>Page</b>	<b>1</b>
<b>III.</b>	<b>DESCRIPTION OF FUNCTION / TECHNICAL INFORMATION</b>	<b>Page</b>	<b>2</b>
<b>IV.</b>	<b>CONSUMPTION RATES / ENERGY REQUIREMENT / OTHER DATA</b>	<b>Page</b>	<b>6</b>
<b>V.</b>	<b>REPAIRS</b>	<b>Page</b>	<b>7</b>
<b>VI.</b>	<b>SUPPLEMENTS</b>	<b>Page</b>	<b>13</b>

---

## **I. SAFETY INFORMATION**

Before commencing repairs, ALWAYS disconnect the appliance from the power supply! If tests have to be performed while the appliance is live, ALWAYS use a residual-current-operated circuit-breaker! When repairs are complete, perform a function test, as well as a safety test in accordance with VDE 0701.

### **1. Safety test in accordance with VDE 0701**

- Plug in the tester mains plug.  
In the case of switchover models connect L1 and L2 on the tester.
- Switch on the appliance (door must be closed).
- Perform the test.

## **II. OPERATION**

### **1. Selecting the programme**

- “Cottons/coloureds” Turn the programme selector in a clockwise direction to the desired drying setting (6 automatic drying settings).
- Easy-care Turn the programme selector in an anti-clockwise direction to the desired setting (5 automatic drying settings).
- Timed programme Turn programme selector / time switch to the desired time.

### **2. Buttons**

- ON/OFF Switches the appliance on / off.
- “Low heat” For delicate textiles. The temperature is reduced.



- Signal  
 Button pressed (LED on) – signal emitted in the “anti-creasing” phase.  
 Changing the volume – hold down the button, the signal changes.  
 When the button is released, the volume has been changed and stored.
- Start time\*  
 Switching off the signal – press the button again (LED off).  
 The start time can be specified from 1–19 hours. The running time is indicated by a flashing dot in the 7-segment display.  
 The “anti-creasing” phase is extended to 8 hours.  
 If the Start button is pressed, the appliance starts immediately.  
 If the door is opened during the preselected time, the Start time LED flashes, press the Start time button again – the LED switches to a steady light.
- \*  
 Optional (WTA3480; WTA3500)

**3. Programme progress indicator**

Dampness in the washing is continuously checked by the electronic sensor system. The programme status is displayed by an LED.

**III. DESCRIPTION OF FUNCTION / TECHNICAL INFORMATION**

**1. General information**

The design is based on a fully electronic solution. All control functions are combined on the power module. The selected drying setting is determined by a conductivity measurement. The conductivity measurement of the washing is converted to a voltage measurement.

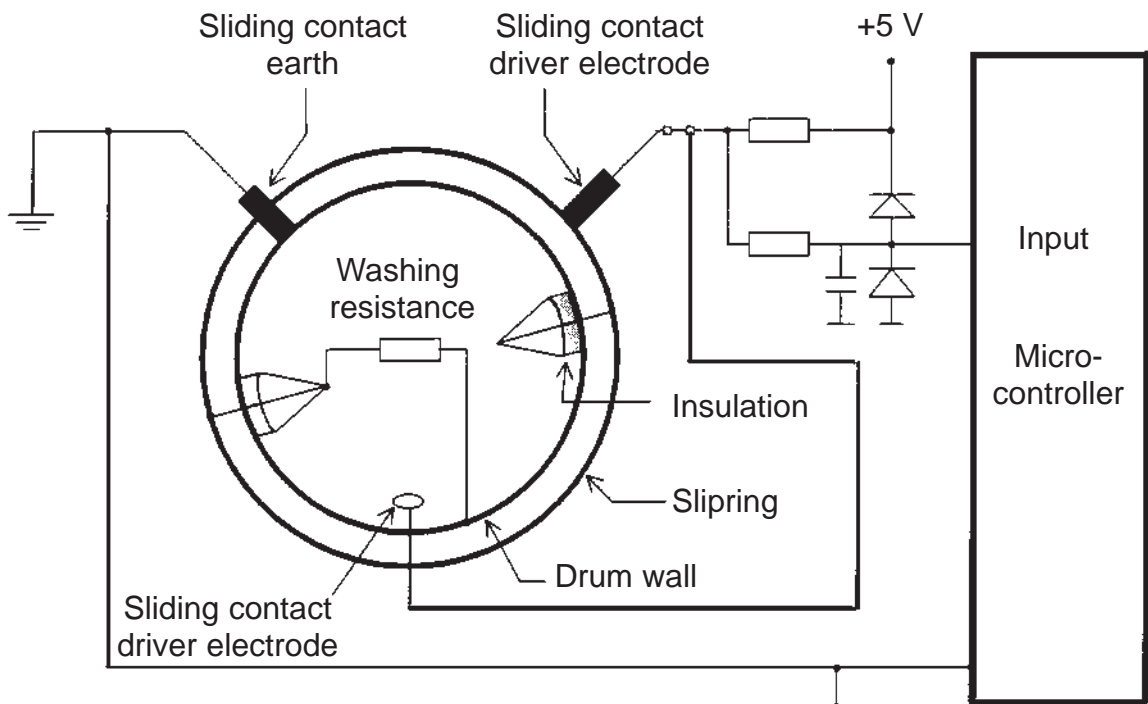



- Operating and display module is situated in the fascia.
- Control and power module is situated on the right frame support.
- Thermistor sensor for measuring the air temperature.
- Condensation pump is situated in the base group underneath the belt tensioning device.
- Motor is situated on the right in the base group.
- Heater on the rear panel – under the heating duct cover.
- Bimetallic thermal cut-out (>170 °C) is situated directly on the heater.

## 1.1 Operating and display module

The operating and display module is used to input and output information. It houses all the direct input buttons, all signalling elements, e.g. LEDs, selector switches and signal transmitters. Models are encoded by breaking off the side bridges.

## 1.2 Control and power module

The module houses all the significant components, e.g. micro-controller, relays, power supply, etc. It performs complex functions with respect to controlling drying sequences, monitoring the temperature, ascertaining parameters and actuating the operating and display section. The appliance is switched over from 16 A to 10 A by means of a wire jumper. Wire jumper closed 16 A – Wire jumper open 10 A. Control and power module ≥ mask V 4.00 (software version is indicated on the processor) changes automatically from 16 A to 10 A.

## 1.3 Thermistor sensor for measuring the air temperature

Thermistor sensors measure the temperature of the process air at three different points in the appliance (NTC thermistor – NTC stands for Negative Temperature Coefficient).

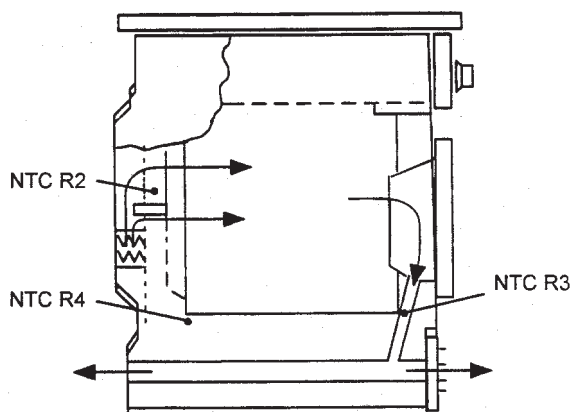

### NTC R3

is situated in the ring insert under the door and measures the exhaust-air temperature.

### NTC R4

is situated in the air current in front of the heater.



## Resistance values NTC R3 / NTC R4

Temperature °C	Resistance kΩ
25	9–11
60	2.3–2.7

## NTC R2

is situated above the heater and measures the temperature of the process air blown into the washing.

Temperature °C	Resistance kΩ
25	18–22
60	4.5–5.5

## 1.4 Motor

The motor drives the drum and the fan.

Specifications:

Rated input when appliance empty:	140 W
Current input when appliance empty:	0.5 A
Motor capacitor, capacity:	11 μF
Nominal frequency:	50 Hz
Nominal voltage:	230 V

## 1.5 Heater

The heater consists of two heating coils E2, E3, the bimetallic thermal cut-out B9 and the NTC R2.

Heat setting 2:	1200 W
Heat setting 3:	1800 W

## 1.6 Bimetallic thermal cut-out (heater)

The thermal cut-out should respond when localised overheating occurs, e.g. if the air flow or electrical temperature control fails.

If a fault occurs, the thermal cut-out must be manually actuated by pressing the red reset button.

Response temperature: 160–175 degrees Celsius

## 1.7 Door switch and safety functions

All relay activations are controlled via the door switch. When the door is open, relays cannot be activated.

When the door is closed and the mains switch is on, the capacitor is charged via a processor output. Its voltage is monitored by an analogue input.



When the door is opened, the capacitor is discharged. If a voltage of less than 1.5 V is measured on the capacitor when the machine is switched on, either the door was opened or a mains failure lasted too long while the appliance was switched off. The programme must then be restarted. If the voltage on the capacitor is still sufficiently high, the programme is reset and restarted following a voltage interruption.

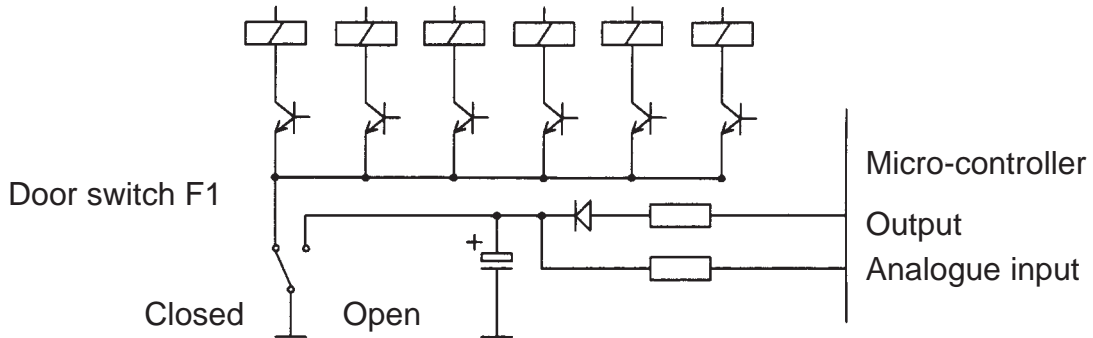

## 2. Principle of heating control

As the heater consists of 2 phase windings which operate at different power levels, a different heating control can be used at various heat settings.

- Heat setting 0 = OFF
- Heat setting 2 = E3
- Heat setting 3 = E2 + E3

The heat setting which is active is dependent on the programme sequence and on the temperatures behind the heater (NTC R2) and on the drum outlet (NTC R3). If the motor rotates in an anti-clockwise direction, the current heat setting is reduced by one (Heat setting 3  $\Rightarrow$  Heat setting 2 or Heat setting 2  $\Rightarrow$  Heat setting 0).

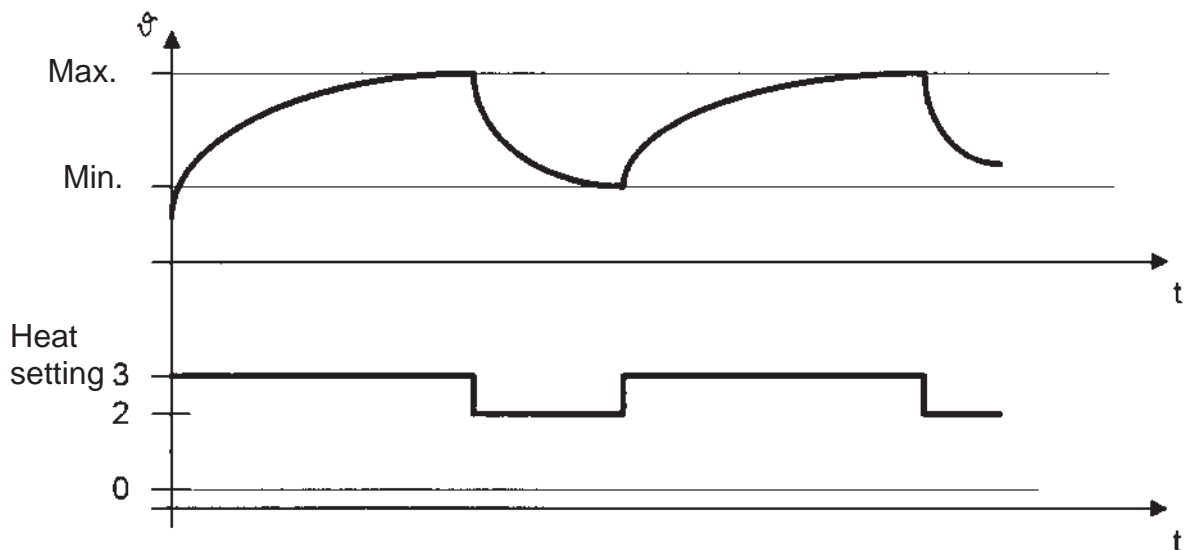

The maximum heat settings and minimum temperature values (NTC R2, NTC R3) permitted for a programme section have been defined in the drying programme. Both temperatures are monitored in parallel, the reset temperature having higher priority.



If the maximum temperatures are exceeded and Heat setting 0 has still not been reached, the heater setting is reduced by one and is maintained for 20 s.

During this time the temperatures are monitored. If they do not drop below the maximum values, the heat setting is reduced again. Conversely, the heat setting is increased if the temperatures drop below one of the minimum values and the maximum heat setting has still not been reached.

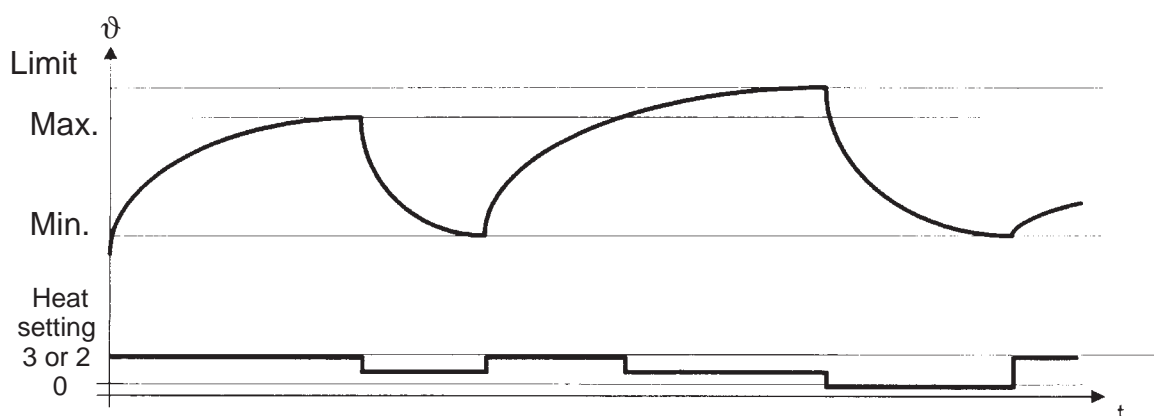

If the temperature limit is exceeded, all heaters are switched off. The heater is not switched on again until the temperature has dropped to  $\vartheta$  min. If the temperature does not drop below the temperature limit within 10x30 sec., the drying process is terminated and an "Overheating" error message (extra dry LED) is output.

#### IV. CONSUMPTION RATES / ENERGY REQUIREMENT / OTHER DATA

1. Energy-efficiency class "C"
2. Energy consumption

	Spin speed in r.p. Approx. values	Drying time in minutes (including 4 min. cooling-down time)	Approx. values	Energy consumption in kWh Approx. values
"Cottons/coloureds" 4-5 kg Cupboard dry	1400	(10/16A)	75/55	2.4
	800	(10/16A)	105/80	3.3
Iron dry	1400	(10/16A)	55/40	2.4
	800	(10/16A)	77/58	2.5
Easy care 2 kg Cupboard dry	1.000	(10/16A)	31/27	1.0

The indicated consumption values are guide values which have been determined under normal conditions. Fluctuations up to 10 % are possible. Low ambient temperatures in the installation location of the vented dryer will result in longer drying times.



## V. REPAIRS

### 1. Troubleshooting

When implementing troubleshooting procedures, please comply with the following:

- All test programmes should be run.
- If “Test component” is indicated in the Procedures column of the troubleshooting table the components are to be tested in accordance with their electrical specification. To test the component, remove the plug from the power module.
- Check that the plug-and-socket connections are properly attached.
- If electronic modules are replaced, note down the result of the test programs on the appropriate label.
- When handling electronic modules, comply with the EGB handling regulations.
- Put the replaced electronic modules back into the original packaging.

Error no.	Error display	Possible cause	Test / Procedure
1	“Drying” LED flashes in the progress indicator = NTC fault (NTC R4)	A Appliance ambient temperature < 0 °C.	Customer instruction: Do not operate the appliance below 0 °C.
		B NTC R4, cable or plug-and-socket connection defective.	Remove the cable from the power module. Test NTC, cable and plug-and-socket connection.
		C Power module defective.	If 1 A and 1 B are o.k., start “BW cupboard dry” test program. If LED in the progress indicator displays NTC fault, replace the power module.
2	“Iron dry” LED flashes in the progress indicator = NTC fault (NTC R2)	NTC R3, cable or plug-and-socket connection defective.	See Error number 1.
3	“Cupboard dry” LED flashes in the progress indicator = NTC fault (NTC R2)	NTC R2, cable or plug-and-socket connection defective.	See Error number 1.
4	“Extra dry” LED flashes in the progress indicator = overheating	A Fluff filter blocked.	Clean the fluff filter.



Error no.	Error display	Possible cause	Test / Procedure
Re 4		B Air-intake / exhaust-air passages blocked.	Test air passages.
		C Overload	Customer instruction: Load < 5 kg dry weight.
		D Fan impeller loose.	Test fan impeller.
		E Motor is not rotating.	See Error number 7.
		F Heater does not switch off.	See Error display 8 B/C.
5	<p>“End” LED flashes (display only in test program!) = time error</p> <ul style="list-style-type: none"> <li>– “Washing not drying properly”</li> <li>– “Drying time too long”</li> <li>– “Dry in 180 / 240 minutes”</li> </ul>	A Washing too wet, initial moisture too high.	Customer instruction.
		B Overload, < 5 kg dry weight.	Customer instruction.
		C Fluff filter blocked.	Clean fluff filter.
		D Thermal cut-out B9 has tripped.	See Error number 14.
		E Short-circuit or shunt circuit in conductivity system.	See Error number 12 B.
		F Heater defective.	See Error number 8.
		G Motor is not rotating.	See Error number 7.
		H Mains voltage too low.	Measure mains voltage under load. Required voltage 230 V (+10 % / -15 %).





Error no.	Error display	Possible cause	Test / Procedure
6	Drum is not rotating.	A Motor is not rotating	See Error number 7.
		B Belt loose, slipping or defective. Clamping device defective.	Test belt and clamping device.
		C Drum blocked or overloaded.	Test drum.
7	Motor is not rotating – rotates only in one direction, – rotates constantly.	A Motor, cable or plug-and-socket connection defective. Motor protector has been actuated. Motor capacitor defective.	Test motor, capacitor and wiring.
		B Door switch defective.	See Error number 15.
		C Power module defective.	Start “BW cupboard dry” test program and measure drive voltage for motor.  Clockwise rotation: Mains voltage between X11–10.5 and X11–10.3;  Anti-clockwise rotation: Mains voltage between X11–10.5 and X11–10.4 Before performing this test, remove the heater plug, as thermal cut-out B9 will trip immediately without the motor.
8	Is not heating.	A Thermal cut-out B9 has tripped.	See Error number 13 B.
		B Heater defective.	Test heater and cable.
		C NTCs defective.	Test NTCs (cold resistance) and wiring.



Error no.	Error display	Possible cause	Test / Procedure
Re 8		D Power module defective.	Start "BW cupboard dry" test program. On the power module measure the drive voltage (mains voltage) for heater E1, 2, 3.
		E Excessive contact resistance in sliding contact system.	See Error number 11 E.
9	Heater continuously on. (Dryer not started.)	A Heater defective.	Test heater and cable.
		B Power module defective.	See Error number 8 C.
10	<ul style="list-style-type: none"> <li>- Washing not drying properly,</li> <li>- Too damp.</li> </ul>	A Wrong programme selected.	Customer information: Select higher degree of dryness.
		B Door switch or power module defective.	See Error numbers 15 A and 15 B.
		C Excessive contact resistance in conductivity system.	Start "Gentle dry" test program. Short-circuit between the agitator and drum. If an error is displayed: Test sliding contact system and internal contact between agitators for continuity. Max. 1 kΩ between agitator and Pin 3 on the plug. Max. 1 kΩ between drum and Pin 1 on the plug. If resistance is o.k.: Repeat test program, with jumper between plug-and-socket connection X11-15.1 and X11-15.3. If there is no error display, do <b>not</b> replace the power module.



Error no.	Error display	Possible cause	Test / Procedure
11	Washing too dry.	A Wrong programme selected.	Customer information: Select lower degree of dryness.
		B Short-circuit or shunt circuit in conductivity system.	Start "Gentle dry" test program. Do <b>not</b> short-circuit between the agitator and drum. If an error is displayed: Remove plug-and-socket connection X11-5 from the power module: If an error is still displayed, then replace the power module. If an error is not displayed: Test the sliding contact system. Remove plug-and-socket connection X11-5 from the power module and measure the resistance between Pin 1 and Pin 3 on the plug (< 500 V). Insulation resistance > 20 MΩ.
12	Appliance dries for only 9–13 minutes.	Empty drum, dry washing.	Customer information: After approx. 9–13 minutes dryer recognises empty drum and / or dry washing.
13	Thermal cut-out B9 has tripped.	A Motor is not rotating.	See Error number 7.
		B Fan impeller loose.	Test fan impeller.
		C Fluff filter blocked.	Clean fluff filter.
		D Heater defective.	Test heater and cable.
14	Start LED does not switch to a steady light, appliance does not start.	Door not closed.	



Error no.	Error display	Possible cause	Test / Procedure
Re 14		A Door switch F1 and / or locking mechanism defective.	Remove plug X11-1 from the power module. Test switch, cable, plug and mechanism – Locking hook – Bowden cable – Door button
		B Power module defective.	Remove plug from the power module, short-circuit Pin 7 and 5 on plug-and-socket connection X11-1 on the power module and start any drying programme. If the appliance starts, the power module is o.k.
15	Appliance does not start.	Operating module defective.	Activate test mode; If this mode can be activated, the operating module is o.k. Check whether the circuit board has become detached from the operating module. If not, continue with Error number 15.
16	Button, display or programme selection malfunctions occasionally.	Operating module or power module defective.	Start “extra dry” and “very dry” test programmes.
17	Filter LED flashes, filter is clean.	A Overheating	See Error number 4.
		B NTC R2 or NTC R4 defective.	Remove the cable from the power module. Test NTC, cable and plug-and-socket connection.



Error no.	Error display	Possible cause	Test / Procedure
18	Starts by itself when switched on.	Appliance was switched off during a drying cycle.	Customer information: If the appliance switches off and subsequently switches on again while a drying programme is running, the appliance is starting by itself in order to terminate the programme which was started.

## VI. SUPPLEMENTS

### 1. Power and control module

Changed software mask 3 (software version V 3.00 is indicated on the processor).

- ⇒ Reduced heat output in the time programme.
- ⇒ Empty drum or dry washing identified within 5 minutes (-2 % relative humidity).
- ⇒ Clocking at reduced heat output.
- ⇒ No stop function when start button pressed again.

### 2. Spark discharge between belt clamping device and motor connector plug

Drive belts were occasionally manufactured with an insufficient carbon content, resulting in a static charge build-up between the belt wheel and drive belt. In these cases the drive belt (Mat. no.: 15 4142) must be replaced.

### 3. Improvement in temperature control in the heat registers

All heaters will receive a new thermal cut-out (modified design). Thermal cut-outs (Mat. no.: 15 4132) and NTC (Mat.: no. 15 4186) are no longer available as spare parts. If required, heaters in appliances with customer-service index /01 should be completely replaced.

### 4. Increase to customer-service index /02

Individual parts of the heater (NTC and thermal cut-out) are available again as spare parts.



**5. New control and power module**

Appliances from FD 7704 will receive a new control and power module mask 4 (software version V 4.00 is indicated on the processor).

- ⇒ Instead of “clocking” – “scan” conductivity measurement – identification of empty drum or dry washing identified (4 minutes).
- ⇒ Scan at changed reserve times 40 sec. on right / 20 seconds on left.
- ⇒ Time remaining display in time programme in minutes (appliances with \*
- ⇒ Changed fluffing recognition system (filter / cooler). NTC R4 is not applicable.
- ⇒ Changed temperature ranges of the NTCs. NTC R3 –15 °C / 105 °C.  
NTC R2 –15 °C / 200 °C.
- ⇒ Switchover model from 16 A to 10 A via test program.
  - ◆ Activate test program.
  - ◆ Set programme selector to rotary-iron dry.
  - ◆ Press Start button.

Display model	<ul style="list-style-type: none"> <li>◆ 16 A model</li> <li>◆ 10 A model</li> </ul>	Display 16 “Low heat” LED on  Display 10 “Low heat” LED off
Switch over model	<ul style="list-style-type: none"> <li>◆ Press “Low heat” button</li> <li>◆ Press Start button</li> </ul>	Display and “Low heat” LED flash  The last displayed status is acknowledged

**6. Buzzer on the operating module**

The buzzer on the operating module is available as a spare part (Mat. no.: 16 8577) from the logistics centre in Fürth. When replacing the buzzer, note the polarity on the instruction leaflet.

**7. Increase to customer-service index /04**

Control and power module mask 5 (software version V 5.00 is indicated on the processor), process fan drum and heater new. The modified software reduces the process temperature (NTC R2 heater, NTC R3 exhaust air). Fan drum (process air) has been changed from 145 mm to 155 mm. To obtain a more satisfactory measurement of the air flow, the position of the NTC and thermal cut-out on the heater has been changed.

\* Etwas fehlt hier



### 8. Drum bearing at the rear

A new plastic drum bearing was used during the production period FD7710–FD7803. The assembly kit (**Mat. no.: 15 4177**) is also available as a spare part.

See diagram for installation.

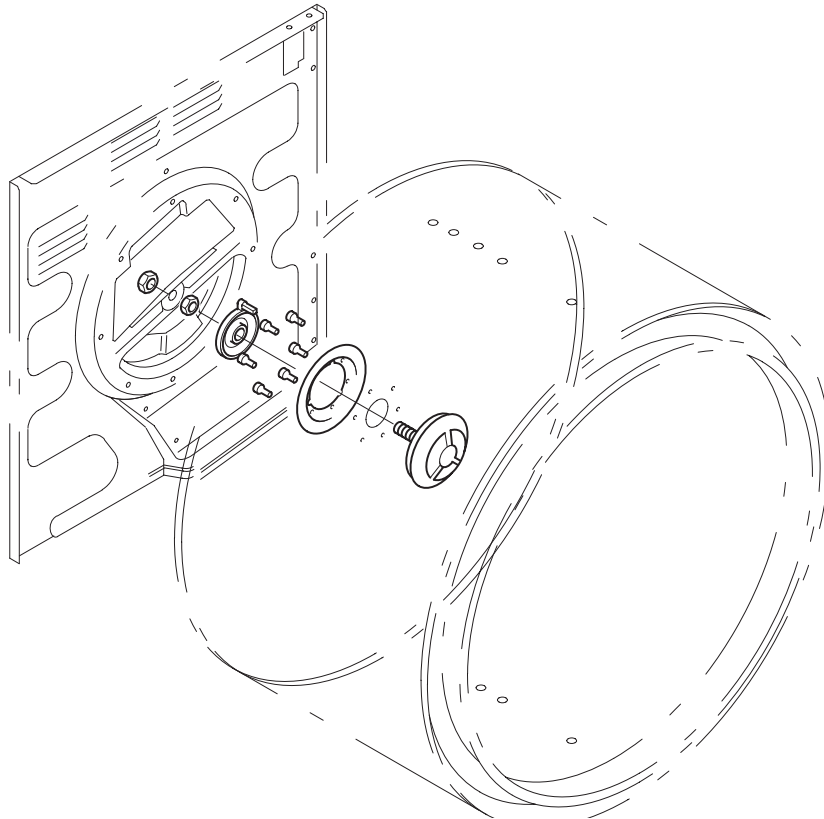

### 9. Increase to customer-service index /06

New base group consisting of an upper and lower section. As the exhaust air distributor is integrated, noise is reduced. The new base group has been in use since 08.98.

### 2.3 Test Programme Components and NTC's (Cottons/Regular Reg. Dry ☉)

The following components are tested during this programme: pump, motor and heater and the NTC are checked.

NTC faults are displayed by flashing the LED's.  
See fault display no. 3.

Time in seconds	3	5	5	2	5	2	5	29	15
Pump <input checked="" type="checkbox"/>									
Motor <input type="checkbox"/>									
right rotation									
Motor off									
left rotation									
Heater E2									
E3									

Drum reverses: 5' on, 1' off

not for models with air drying

### 2.4 Test Programme Conductance Measurement (Cottons/Regular Light Dry ☉)

To measure the conductance the paddles and the inner drum must be connected together.

The door can be open during this programme.

	LED 'Drying'	LED 'Damp Dry'	
Drum empty, no connection between paddles and drum	on	off	No fault
	off	off	Fault: Short circuit or bypass resistance of conductor
Connection between paddles and drum	off	on	No fault
	off	off	Fault: Open circuit or resistance of conductor too high

### 3. Fault Display

A fault is displayed when the following LED's are flashing.

Fault	Indicator/LED					7 seg. display
	Drying	Damp Dry	Regular Dry	Extra-Dry	End	
NTC R3 -15° - 105°C		×				E1
NTC R2 -15° - 200°C			×			
Overheat				×		
Time fault					×	
Condensation is not pumped off						×

### 4. Ending each test programme

Each test programme can be cancelled by pressing the start button.

### 5. Cancelling test mode

To cancel the test mode switch off appliance.

### 6. Safety Test

- Connect appliance to test meter
- Switch on appliance
- Carry out insulation and megger test.

GB

518 5058 AA1	Issue: B	06.98
T 74	SO-20/ 0986	



### 1. Selecting the Test Mode

- Programmer and timer must be set to the 12 clock position.
- Press and hold in simultaneously the start and delicate button and switch on appliance.
- The test mode is now activated and the start LED will flash rapidly.
- N.B. The last fault which has stopped the appliance from functioning will be stored in the memory until one of the following test programmes is activated.

### 2. Selecting the Test Programme

The following test programme can be selected via the programme selector

- Cottons/Regular Extra Dry ☉ = Indicators/Display
- Cottons/Regular Very Dry ☉ = buttons and selector switch
- Cottons/Regular Reg. Dry ☉ = components and NTC's
- Cottons/Regular Light Dry ☉ = conductance measurement

Start the test programme by pressing the start button. The start LED will be continuously illuminated. The test programme has finished once the start LED starts flashing again.

*N.B. Do not turn the programme selector or press the buttons during the test programme - it will stop the test programme.*

### 3. Test Programme

(Cottons/Regular Extra Dry ☉)

#### Indicators/Display

All LEDs and LCD display (showing 8) will be illuminated for 4 seconds (the LEDs and LCD are less bright than in normal operation). Each LED will light up, one after the other. At the same time the LCD will count from 0 upwards. The start LED is not illuminated continuously during the test programme. The test programme can be ended via the start button.

N.B. Due to the variations in the modules it is possible that pauses occur when no LED will be illuminated during the test.

### 4. Test Programme Buttons and Selector Switch (Cottons/Regular Very Dry ☉)

Buttons:

Whilst pressing each button, the respective LED should light up.

Selector Switch:

When selecting each position on the selector switch, the LED should light up in accordance with the tables.

Appliances without time delay:

Position	Indicator/LED				
	Drying	Damp Dry	Regular Dry	Extra Dry	End
Off					
Cottons/Regular Extra Dry ☉	×				
Very Dry ☉		×			
Regular Dry ☉			×		
Light Dry ☉				×	
Econo Dry ☉					×
Cottons/Regular Damp Dry ☉	×	×			
Heated Dry	×		×		
Air Fluff	×			×	
Heated Dry	×				×
Air Fluff		×	×		
Permanent Press Extra Dry ☉		×		×	
Very Dry ☉		×			×
Regular Dry ☉			×	×	
Light Dry ☉			×		×
Econo Dry ☉				×	×
Off					

Appliances with time delay  
1. Time delay in off position

Position of programmer	Indicator/LED				
	Drying	Damp Dry	Regular Dry	Extra Dry	End
Off					
Cottons/Regular Extra Dry ☉	×				
Very Dry ☉		×			
Regular Dry ☉			×		
Light Dry ☉				×	
Econo Dry ☉					×
Cottons/Regular Damp Dry ☉	×	×			
Permanent Press Extra Dry ☉	×		×		
Very Dry ☉	×			×	
Regular Dry ☉	×				×
Light Dry ☉		×	×		
Econo Dry ☉		×		×	
Off					

2. Programmer at off

Position of timer	Drying	Damp Dry	Regular Dry	Extra Dry	End
Off					
Heated Dry		×			×
Air Fluff			×	×	
Heated Dry			×		×
Air Fluff				×	×
Off					

GB

518 5048 AA2	Issue: B	06.98
T 74	S0-20/0985	

		Internal enquiry ●	Drying selection						Cooling down	Anti-crease
Degree of dryness			Damp Dry ⓪	Econo Dry ⓪	Light Dry ⓪	Regul. Dry ⓪	Very Dry ⓪	Extra Dry ⓪		
LED display <input checked="" type="checkbox"/>		Drying	Drying	Damp Dry	Damp Dry	Regular Dry	Regular Dry	Extra Dry	Drying selection	Anticrease /End
Values when moisture content or time is reached	moisture content (%)	Cottons/Regular Permanent Press with Delicates button } -2	} 20	} 12	} 8	0±2 2±2 0	*** -2	*** -4		
	Time (minutes)	Cottons/Regular Permanent Press with Delicates button Heated Dry Air Fluff } 1 } = 3	} 100	} 100	} 100	} 100 10 - 90 10 - 90	=10 = 5 =10	=10 = 5 =10	} = 4	} 35
Heater	Cottons/Reg. u. Permanent Press	E2 + E3 E3								
	with Delicates button	E2 + E3 E3								
	Heated Dry and Heated Dry with Delicates button	E3								
Temp. control (°C)	Cottons/Regular	NTC R2	75°-95°							
		NTC R3	55°-65°							
	Heated Dry	NTC R2	70°-90°							
		NTC R3	55°-65°							
	Permanent Press	NTC R2	75°-95°							
		NTC R3	55°-65°							
with Delicates button	NTC R2	55°-75°								
		NTC R3	45°-55°							
Overload ●	B9	100°								
	NTC R2	130°								
Drum reverses 8' 'right / 8' 'left										
Drum reverses 40' 'right / 20' 'left		*								
Drum reverses 110' 'right / 10' 'left										
Drum 5' 'left / 110' 'off										

\*\*\* no fixed level

'Drying' LED lights up as soon as programme starts  
LED's 'Damp Dry' ... 'End' do not light up until equivalent stage of drying is reached

max. appliance running time 240 min.

● Detection of 'Fluff filter blocked' (R2 rinses) or 'Overheating' result in programme being terminated (motor is no longer actuated).

\* Left rotation without heating

● not applicable for Heated Dry and Air Fluff

GB

518 5038 AA3	Issue: C	06.98
T 65	S0-20/ 0984	

		Internal enquiry ●	Drying selection					Cooling down	Anti-crease	
Degree of dryness			Damp Dry ⊖	Econo Dry ⊖	Light Dry ⊖	Regul. Dry ⊖	Very Dry ⊖	Extra Dry ⊖		
LED display ■		Drying	Drying	Damp Dry	Damp Dry	Regular Dry	Regular Dry	Extra Dry	Drying selection	Anticrease/End
Values when moisture content or time is reached	moisture content (%)	Cottons/Regular Permanent Press with Delicates button } -2	} 20	} 12	} 8	0±2 2±2 0	*** -2	*** -4		
	Time (minutes)	Cottons/Regular Permanent Press with Delicates button } =3	} 120	} 100	} 100	100 10-90 10-90	=10 = 5 =10	=10 = 5 = 5	} = 8	} 35
Heater	Cottons/Reg. u. Permanent Press	E2 + E3 E3								
	with Delicates button	E3								
	Heated Dry and Heated Dry with Delicates button	E3								
Temperature control (°C)	Cottons/Regular	NTC R2	100°-130°							
		NTC R3	78°- 80°							
	Heated Dry	NTC R2	85°-115°							
		NTC R3	78°- 80°							
	Permanent Press	NTC R2	100°-130°							
		NTC R3	74°- 78°							
with Delicates button	NTC R2	85°-115°								
	NTC R3	68°- 70°								
Overload ●	B9	120°								
	NTC R2	145°								
Drum reverses 8' 'right / 8' 'left										
Drum reverses 40' 'right / 20' 'left	*									
Drum reverses 110' 'right / 10' 'left										
Drum 5' 'left / 110' 'off										
Condensation pump 30' 'on / 90' 'off										

\*\*\* no fixed level

- 'Drying' LED lights up as soon as programme starts  
LEDs 'Damp Dry' ... 'End' do not light up until equivalent stage of drying is reached
- Detection of 'Fluff filter blocked' (R2 rises) or 'Overheating' result in programme being terminated
- \* Left rotation without heating
- not applicable for Heated Dry and Air Fluff

max. appliance running time 240 min.

LED-display Lint-Filter after 120' '  
LED switches off after 10' ' when reset.



518 5028 AA4	Issue: C	11.99
T 74	SO-20/ 0983	

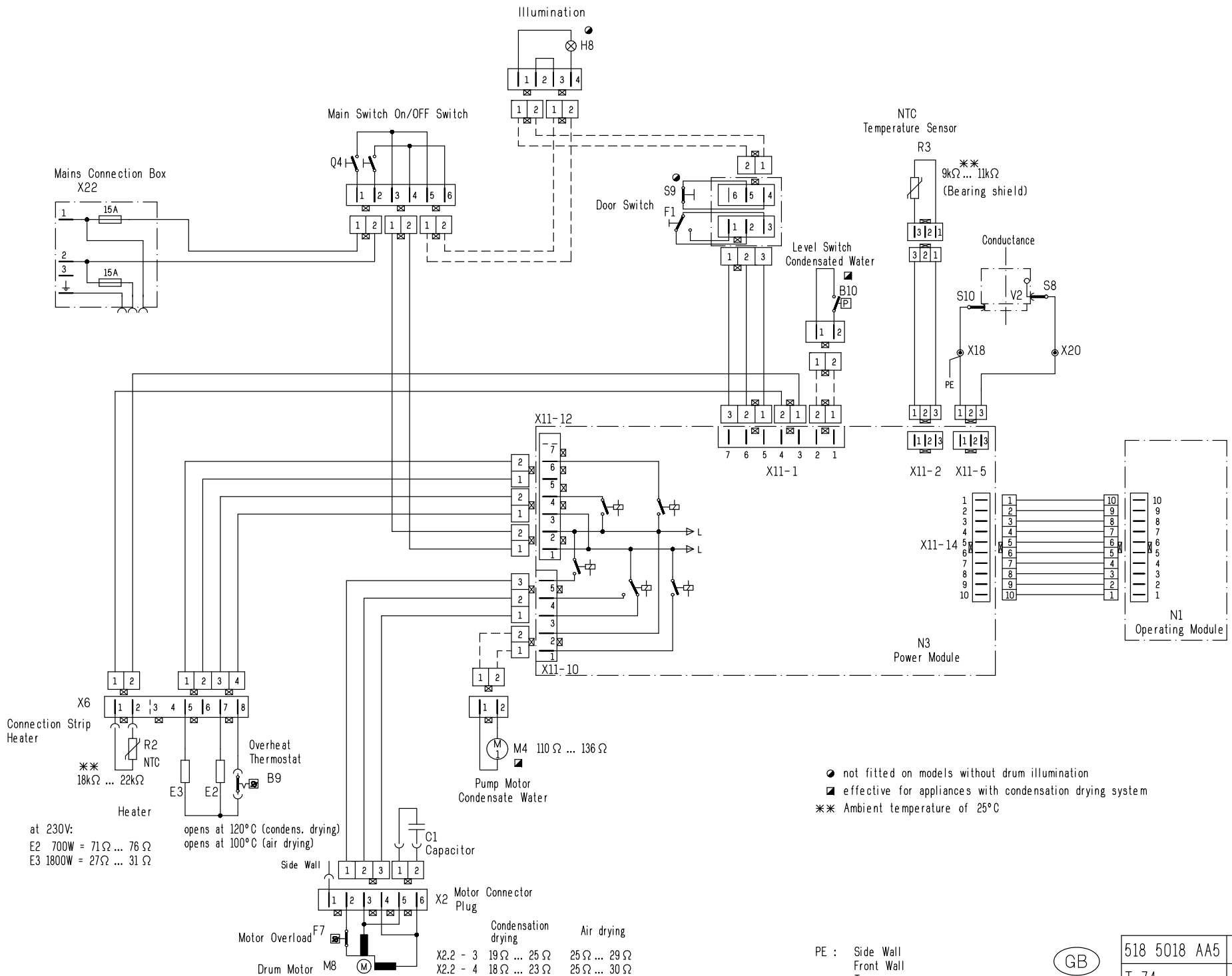

● not fitted on models without drum illumination  
 ■ effective for appliances with condensation drying system  
 \*\* Ambient temperature of 25°C

PE : Side Wall  
 Front Wall  
 Traverse



518 5018 AA5	Issue:C	11.99
T 74	S0-20/0982	

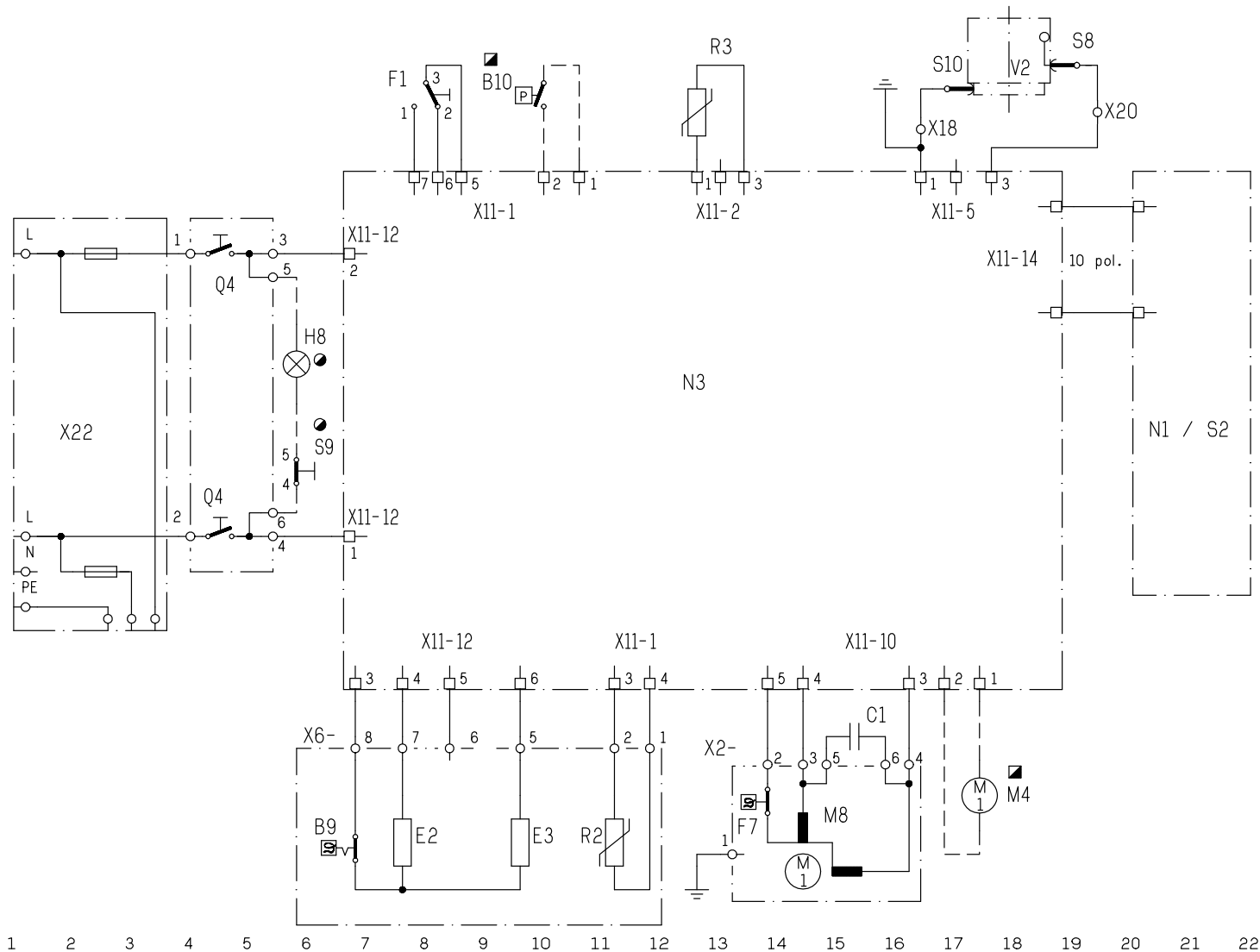

List of Components Current Path

B9	Overheat Thermostat	7
B10	Level Switch Condensated Water	10
C1	Capacitor	15
E2	Heater	10
E3	Heater	8
F1	Door Switch	8
F7	Motor Overload	14
H8	Illumination	6
M4	Pump Motor Condensate Water	8
M8	Drum Motor	15
N1	Operating Module	21
N3	Power Module	6-19
Q4	Main Switch On/Off Switch	4
R2	NTC Temperature Sensor	11
R3	NTC Temperature Sensor	13
S2	Selector Switch	21
S8	Sliding Contact-Conductance	19
S9	Door Switch	6
S10	Sliding Contact earth	17
V2	Electrode Conductance	18
X2	Motor Connector Plug	13-16
X6	Connection Strip Heater	7-11
X11	Plug in Connection Module	6-22
X18	Connector	16
X20	Connector	20
X22	Mains Connection Box	2

□ Plug in Connection Module

■ effective for appliances with condensation drying system  
 ● not fitted on models without drum illumination

GB

518 5008 AA6	Issue: C	11.99
T 74	SO-20/0981	